



Operation & Maintenance Manual

*Original Instructions
Keep this manual with machine at all times.*

Model TH255

S/N TBS00100 & After

31200362

*Revised
November 2, 2011*

CALIFORNIA PROPOSITION 65
BATTERY WARNING

**Battery posts,
terminals and related
accessories contain
lead and lead compounds,
chemical known to the
State of California
to cause cancer and
reproductive harm.**

**WASH HANDS
AFTER HANDLING!**

CALIFORNIA PROPOSITION 65
EXHAUST WARNING

**Diesel Engine exhaust and
some of its constituents
are known to the State of
California to cause cancer,
birth defects and other
reproductive harm.**

REVISION LOG

February 20, 2008 - A - Original Issue of Manual

May 1, 2008 - B - Revised manual.

August 4, 2009 - C - Revised pages b, c, d, 1-2 thru 1-6, 1-9, 2-1, 2-4 thru 2-7, 2-9, 2-10, 3-2 thru 3-5, 3-7 thru 3-13, 4-1, 4-2, 4-4 thru 4-9, 4-11, 5-1, 5-2, 5-4, 5-6, 5-7, 5-9 thru 5-12, 5-16, 5-18 thru 5-28, 6-1, 7-2, 7-4, 7-5, 7-8, 7-13, 8-1 & 9-1 thru 9-4.

December 15, 2009 - D - Revised cover.

October 10, 2011 - E - Revised pages 2-7, 2-8, 2-9, 3-8, 3-9, 3-10, 7-4, 8-1 & 9-3.

November 2, 2011 - F - Revised pages 2-5, 2-7, 3-9, 3-11 & 9-3.

Read This First

This manual is a very important tool! Keep it with the machine at all times.

The purpose of this manual is to provide owners, users, operators, lessors, and lessees with the precautions and operating procedures essential for the safe and proper machine operation for its intended purpose.

Due to continuous product improvements, JLG Industries, Inc. reserves the right to make specification changes without prior notification. Contact JLG Industries, Inc. for updated information.

Operator Qualifications

The operator of the machine must not operate the machine until this manual has been read, training is accomplished and operation of the machine has been completed under the supervision of an experienced and qualified operator. Operation within the U.S.A. requires training per OSHA 1910.178.

Operators of this equipment must possess a valid, applicable driver's license, be in good physical and mental condition, have normal reflexes and reaction time, good vision and depth perception and normal hearing. Operator must not be using medication which could impair abilities nor be under the influence of alcohol or any other intoxicant during the work shift.

In addition, the operator must read, understand and comply with instructions contained in the following material furnished with the telehandler:

- This Operation & Maintenance Manual
- Telehandler Safety Manual (ANSI only)
- All instructional decals and plates
- Any optional equipment instructions furnished

The operator must also read, understand and comply with all applicable Employer, Industry and Governmental rules, standards and regulations.

Modifications

Any modification to this machine must be approved by JLG.

This product must comply with all safety related bulletins. Contact JLG Industries, Inc. or the local Caterpillar dealer representative for information regarding safety-related bulletins which may have been issued for this product.

JLG Industries, Inc. sends safety related bulletins to the owner of record of this machine. Contact JLG Industries, Inc. to ensure that the current owner records are updated and accurate.

JLG Industries, Inc. must be notified immediately in all instances where JLG products have been involved in an accident involving bodily injury or death of personnel or when damage has occurred to personal property or the JLG product.

FOR:

- Accident Reporting and Product Safety Publications
- Current Owner Updates
- Questions Regarding Product Applications and Safety
- Standards and Regulations Compliance Information
- Questions Regarding Product Modifications

CONTACT:

Product Safety and Reliability Department
JLG Industries, Inc.
13224 Fountainhead Plaza
Hagerstown, MD 21742
USA

In USA:

Toll Free: 1-877-JLG-SAFE (1-877-554-7233)

Outside USA:

Phone: +1-717-485-6591

E-mail:

ProductSafety@JLG.com

Read This First

Other Publications Available

Service Manual.....	31200364
Parts Manual	31200363

Note: *The following standards may be referenced in this manual:*

ANSI is compliant to ANSI/ITSDF B56.6

AUS is compliant to AS 1418.19

CE is compliant to EN1459

Refer to the machine Serial Number Plate to identify the applicable compliance standard.

TABLE OF CONTENTS

Revision Log

Read This First

Operator Qualifications	b
Modifications	b
Other Publications Available	d

Table of Contents

Section 1 - General Safety Practices

1.1 Hazard Classification System	1-1
Safety Alert System and Safety Signal Words	1-1
1.2 General Precautions	1-1
1.3 Operation Safety	1-2
Electrical Hazards	1-2
Tip Over Hazard	1-3
Travel Hazard	1-6
Load Falling Hazard	1-7
Lifting Personnel	1-8
Driving Hazards On Slopes	1-9
Pinch Points and Crush Hazards	1-10
Fall Hazard	1-12
Chemical Hazards	1-13

Section 2 - Pre-Operation and Inspection

2.1 Pre-Operation Check and Inspection	2-1
2.2 Safety Decals	2-4
ASME (ANSI, if equipped)	2-4
ISO (CE & AUS) (ANSI, if equipped)	2-6
2.3 Walk-Around Inspection	2-8
2.4 Warm-Up and Operational Checks	2-10
Warm-Up Check	2-10
Operational Check	2-10
2.5 Operator Cab	2-11
2.6 Windows	2-12
Cab Door Window (if equipped)	2-12
Rear Window	2-13

Section 3 - Controls and Indicators

3.1 General	3-1
3.2 Controls	3-2
Park Brake	3-4
Parking Procedure	3-5
Ignition	3-6

Table of Contents

	Transmission Control Lever.....	3-7
	Load Stability Indicator - LSI (CE & AUS)	3-8
	LSI Override Switch (CE & AUS).....	3-11
	Instrument Panel	3-12
	Steering Column Adjuster (if equipped).....	3-13
	Joystick.....	3-14
	Right Hand Console	3-16
	Accessory Control Lever (if equipped)	3-18
3.3	Steer Modes	3-19
	Steer Mode Change	3-19
3.4	Operator Seat.....	3-20
	Adjustments.....	3-20
	Seat Belt.....	3-21
3.5	Boom Angle and Extension Indicators	3-22

Section 4 - Operation

4.1	Engine	4-1
	Starting the Engine	4-1
	Battery Boosted Starting.....	4-2
	Normal Engine Operation	4-3
	Shut-Down Procedure	4-3
4.2	Operating with a Non-Suspended Load	4-4
	Lift Load Safely	4-4
	Before Picking Up a Load.....	4-4
	Transporting a Load	4-5
	Leveling Procedure.....	4-5
	Placing a Load.....	4-6
	Disengaging a Load.....	4-6
4.3	Operating with a Suspended Load (ANSI & CE).....	4-7
	Lift Load Safely	4-7
	Picking Up a Suspended Load	4-7
	Transporting a Suspended Load	4-8
	Leveling Procedure.....	4-8
	Placing a Suspended Load.....	4-9
	Disengaging a Suspended Load	4-9
4.4	Road Operation (CE).....	4-10
4.5	Loading and Securing for Transport.....	4-11
	Tiedown	4-11
	Lifting.....	4-12

Section 5 - Attachments and Hitches

5.1 Approved Attachments5-1

5.2 Unapproved Attachments5-1

5.3 JLG Supplied Attachments5-2

5.4 Telehandler/Attachment/Fork Capacity.....5-4

5.5 Use of the Load Chart.....5-5

 Capacity Indicator Locations5-5

 Sample Load Chart (ANSI & CE).....5-6

 Sample Load Chart (AUS)5-7

 Example5-8

5.6 Attachment Installation5-9

 Standard Quick Coupler.....5-9

 Universal Quick Coupler (UQC).....5-12

5.7 Hydraulic Operated Attachment.....5-14

5.8 Adjusting/Moving Forks.....5-15

5.9 Attachment Operation5-16

 Carriage w/Forks.....5-18

 Fork Mounted Hook (ANSI & CE)5-19

 Rotate/Side Tilt Carriage.....5-20

 Side Shift Carriage5-22

 Bucket5-24

 Grapple Bucket5-26

 Material Handling Arm (ANSI & CE)5-28

5.10 Hitches5-29

 Pin Hitch.....5-29

 Adjustable Pin Hitch5-30

 Adjustable Auto Hitch.....5-31

Section 6 - Emergency Procedures

6.1 Towing a Disabled Product.....6-1

 Moving Short Distances6-1

 Moving Longer Distances6-1

6.2 Emergency Lowering of Boom.....6-2

6.3 Emergency Exit from Enclosed Cab6-2

Section 7 - Lubrication and Maintenance

7.1 Introduction7-1

 Clothing and Safety Gear.....7-1

7.2 General Maintenance Instructions7-2

7.3 Service and Maintenance Schedule7-3

 10 & 1st 50 & 50 Hour Maintenance Schedule7-3

 1st 250, 250 & 500 Hour Maintenance Schedule7-4

 1000 Hour Maintenance Schedule.....7-5

Table of Contents

7.4	Lubrication Schedules	7-6
	250 Hour Lubrication Schedule	7-6
7.5	Operator Maintenance Instructions	7-8
	Fuel System.....	7-8
	Engine Oil.....	7-10
	Hydraulic Oil	7-11
	Tires.....	7-12
	Air Intake System	7-14
	Engine Cooling System	7-16
	Battery	7-17
	Brake System	7-18
	Windshield Washer System (if equipped).....	7-19

Section 8 - Additional Checks

8.1	General.....	8-1
8.2	Load Stability Indicator System (CE & AUS).....	8-1

Section 9 - Specifications

9.1	Product Specifications.....	9-1
	Fluids	9-1
	Capacities.....	9-2
	Tires.....	9-2
	Performance	9-3
	Dimensions.....	9-4
	Declaration of Vibration (CE).....	9-5
	Noise Emission Level (CE).....	9-5

Index

Inspection, Maintenance and Repair Log

SECTION 1 - GENERAL SAFETY PRACTICES

1.1 HAZARD CLASSIFICATION SYSTEM

Safety Alert System and Safety Signal Words



DANGER indicates an imminently hazardous situation which, if not avoided, will result in death or serious injury.



WARNING indicates a potentially hazardous situation which, if not avoided, could result in death or serious injury.



CAUTION indicates a potentiality hazardous situation which, if not avoided, may result in minor or moderate injury.

1.2 GENERAL PRECAUTIONS



Before operation, read and understand this manual. Failure to comply with the safety precautions listed in this manual could result in machine damage, property damage, personal injury or death.

Section 1 - General Safety Practices

1.3 OPERATION SAFETY

Electrical Hazards

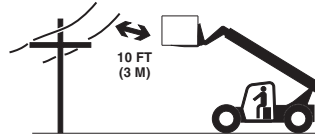
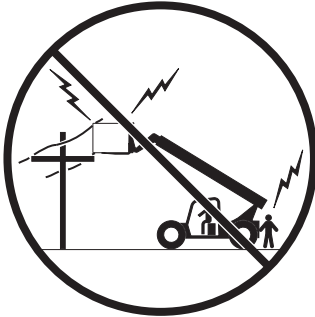

OW0040

- This machine is not insulated and does not provide protection from contact or being near electrical current.
- **NEVER** operate the telehandler in an area where overhead power lines, overhead or underground cables, or other power sources may exist without ensuring the appropriate power or utility company de-energizes the lines.
- Always check for power lines before raising the boom.
- Follow employer, local and governmental regulations for clearance from powerlines.

Tip Over Hazard

General

- For additional load requirements, refer to the appropriate load chart.

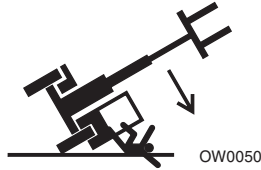

- Never use an attachment without the appropriate JLG approved load chart installed on the telehandler.
- Understand how to properly use the load charts located in cab.
- **DO NOT** exceed rated lift capacity.
- Be sure that the ground conditions are able to support the machine.

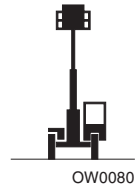
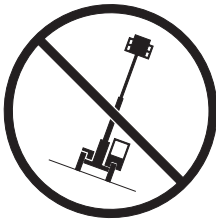

- **DO NOT** raise boom unless frame is level (0 degrees), unless otherwise noted on load chart.

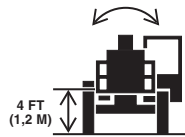
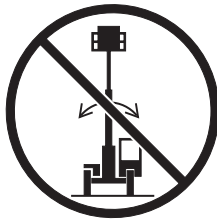

OW0100

- **DO NOT** level machine with boom/attachment above 4 ft (1.2 m). (AUS - **DO NOT** level machine with load more than 300 mm (11.8 in) above ground surface.)

Section 1 - General Safety Practices

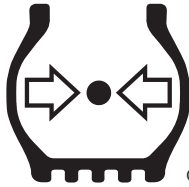

- **MAINTAIN proper tire pressure** at all times. If proper tire pressures are not maintained, this machine could tip over.
- Refer to manufacturer's specifications for proper fill ratio and pressure requirements for tires equipped with ballast.



- Always wear the seat belt.
- Keep head, arms, hands, legs and all other body parts inside operator's cab at all times.



If the telehandler starts to tip over:

- **DO NOT JUMP**
- **BRACE YOURSELF** and **STAY WITH THE MACHINE**
- **KEEP YOUR SEAT BELT FASTENED**
- **HOLD ON FIRMLY**
- **LEAN AWAY FROM THE POINT OF IMPACT**

Non-Suspended Load



OW0060

- **DO NOT** drive with boom raised.

Suspended Load

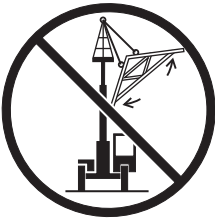

OW0150

- Tether suspended loads to restrict movement.
- Weight of all rigging (slings, etc.) must be included as part of load.
- Beware of wind. Wind can cause a suspended load to swing and cause dangerous side loads - even with tag lines.
- **DO NOT** attempt to use telehandler frame-leveling to compensate for load swing.
- Keep heavy part of load closest to attachment.
- Never drag the load; lift vertically.

When driving with a suspended load:

- Start, travel, turn and stop slowly to prevent load from swinging.
- **DO NOT** extend boom.
- **DO NOT** raise the load more than 11.8 in (300 mm) above ground surface or the boom more than 45°.
- **DO NOT** exceed walking speed.

Section 1 - General Safety Practices

Travel Hazard

2-Wheel Front Steer

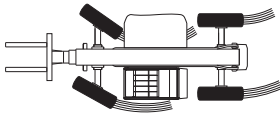

OAL2030

4-Wheel Circle Steer

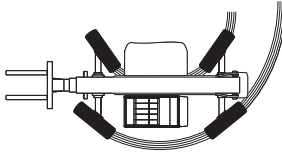

4-Wheel Crab Steer

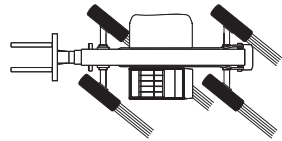

- Steering characteristics differ between steer modes. Identify the steer mode settings of the telehandler being operated.
- **DO NOT** change steer modes while traveling. Steer modes must be changed while telehandler is stationary.
- Visually verify proper wheel alignment after each steer mode change.
- Ensure that adequate clearance is provided for both rear tail swing and front fork swing.
- Look out for and avoid other personnel, machinery and vehicles in the area. Use a spotter if you DO NOT have a clear view.
- Before moving be sure of a clear path and sound horn.
- When driving, retract boom and keep boom/attachment as low as possible while maintaining visibility of mirrors and maximum visibility of path of travel.
- Always look in the direction of travel.
- Always check boom clearances carefully before driving underneath overhead obstructions. Position attachment/load to clear obstacles.
- When driving in high speed, use only front wheel steer (if steering modes are selectable).

Load Falling Hazard

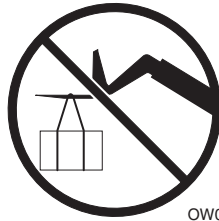

OW0130

- Never suspend load from forks or other parts of carriage.
- **DO NOT** burn or drill holes in fork(s).
- Forks must be centered under load and spaced apart as far as possible.

Section 1 - General Safety Practices

Lifting Personnel



OW0170

- When lifting personnel, **USE ONLY** a JLG approved personnel work platform, with proper load chart displayed in the cab.



OW0190

- **DO NOT** drive machine from cab when personnel are in platform.

Driving Hazards On Slopes

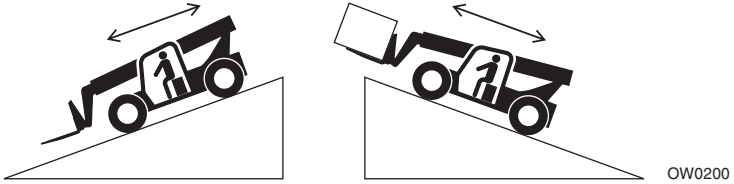

To maintain sufficient traction and braking capabilities, travel on slopes as follows:

- When unloaded, the rear of the machine is the “heavy end.” Drive with forks pointed downhill.
- When loaded, the front of the machine is the “heavy end.” Drive with the forks pointed uphill.
- For additional travel requirements, refer to the appropriate load chart.
- To avoid overspeeding the engine and drivetrain when driving down slopes, downshift to a lower gear and use the service brake as necessary to maintain a slow speed. **DO NOT shift into neutral and coast downhill.**
- Avoid excessively steep slopes or unstable surfaces. To avoid tip over **DO NOT** drive across excessively steep slopes under *any* circumstances.
- Avoid turning on a slope. Never engage “inching” or shift to “Neutral” when going downhill.
- **DO NOT** park on a slope.

Section 1 - General Safety Practices

Pinch Points and Crush Hazards

Stay clear of pinch points and rotating parts on the telehandler.

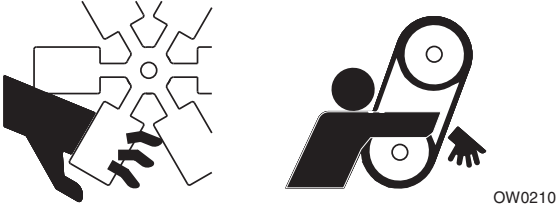

- Stay clear of moving parts while engine is running.



- Keep clear of steering tires and frame or other objects.



- Keep clear from under boom.

Section 1 - General Safety Practices



OW0240

- Keep clear of boom holes.



OW0250

- Keep arms and hands clear of attachment tilt cylinder.



OW0260

- Keep hands and fingers clear of carriage and forks.

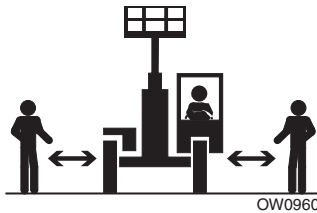

OW0960

- Keep others away while operating.

Section 1 - General Safety Practices

Fall Hazard

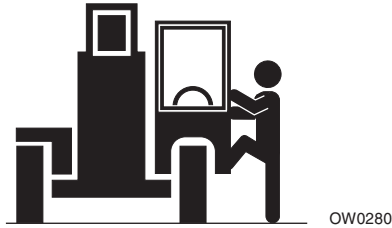

- Enter using the proper hand holds and steps provided. Always maintain 3-point contact when mounting or dismounting. Never grab control levers or steering wheel when mounting or dismounting the machine.
- **DO NOT** get off the machine until the shutdown procedure on page 4-3 has been performed.



- **DO NOT** carry riders. Riders could fall off machine causing death or serious injury.

Chemical Hazards

Exhaust Fumes

- **DO NOT** operate machine in an enclosed area without proper ventilation.
- **DO NOT** operate the machine in hazardous environments unless approved for that purpose by JLG and site owner. Sparks from the electrical system and the engine exhaust can cause an explosion.
- If spark arrestors are required, ensure they are in place and in good working order.

Flammable Fuel



- **DO NOT** fill the fuel tank or service the fuel system near an open flame, sparks or smoking materials. Engine fuel is flammable and can cause a fire and/or explosion.

Hydraulic Fluid



- **DO NOT** attempt to repair or tighten any hydraulic hoses or fittings while the engine is running or when the hydraulic system is under pressure.
- Stop engine and relieve trapped pressure. Fluid in the hydraulic system is under enough pressure that it can penetrate the skin.
- **DO NOT** use your hand to check for leaks. Use a piece of cardboard or paper to search for leaks. Wear gloves to protect hands from spraying fluid.

This Page Intentionally Left Blank

SECTION 2 - PRE-OPERATION AND INSPECTION

2.1 PRE-OPERATION CHECK AND INSPECTION

Note: Complete all required maintenance before operating unit.



WARNING

FALL HAZARD. Use extreme caution when checking items beyond your normal reach. Use an approved ladder.

The pre-operation check & inspection, performed at beginning of each work shift or at each change of operator, should include the following:

1. **Cleanliness** - Check all surfaces for leakage (oil, fuel or battery fluid) or foreign objects. Report any leakage to the proper maintenance personnel.
2. **Structure** - Inspect the machine structure for dents, damage, weld or parent metal cracks or other discrepancies.

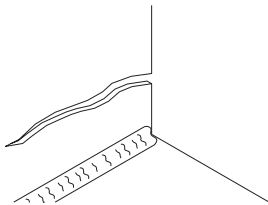

PARENT METAL CRACK

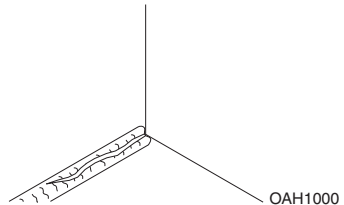

WELD CRACK

3. **Safety Decals** - Ensure all safety decals are legible and in place. Clean or replace as required. See page 2-4 for details.
4. **Operation and Safety Manuals** - Operation & Maintenance Manual and AEM Safety Manual (ANSI only) are located in cab manual holder.
5. **Walk-Around Inspection** - See page 2-8 for details.
6. **Fluid Levels** - Check fluids, including fuel, brake fluid, hydraulic oil, engine oil and coolant. When adding fluids, refer to Section 7 - Lubrication and Maintenance and Section 9 - Specifications to determine proper type and intervals. Before removing filler caps or fill plugs, wipe all dirt and grease away from the ports. If dirt enters these ports, it can severely reduce component life.
7. **Attachments/Accessories** - Ensure correct load charts are installed on the telehandler. If provided, reference the Operation & Maintenance Manual of each attachment or accessory installed for specific inspection, operation and maintenance instructions.

Section 2 - Pre-Operation and Inspection

8. **Operational Check** - Once the walk-around inspection is complete, perform a warm-up and operational check (see page 2-10) of all systems in an area free of overhead and ground level obstructions. See Section 3 - Controls and Indicators for more specific operating instructions.



WARNING

If telehandler does not operate properly, immediately bring machine to a stop, lower boom and attachment to ground and stop the engine. Determine cause and correct before continued use.

This Page Intentionally Left Blank

Section 2 - Pre-Operation and Inspection

2.2 SAFETY DECALS

Ensure all **DANGER**, **WARNING**, **CAUTION** and instructional decals and proper load charts are legible and in place. Clean and replace as required.

Note: Part numbers referenced are for inspection and identification purposes only. Refer to the Parts Manual when ordering replacement parts.

ASME (ANSI, if equipped)

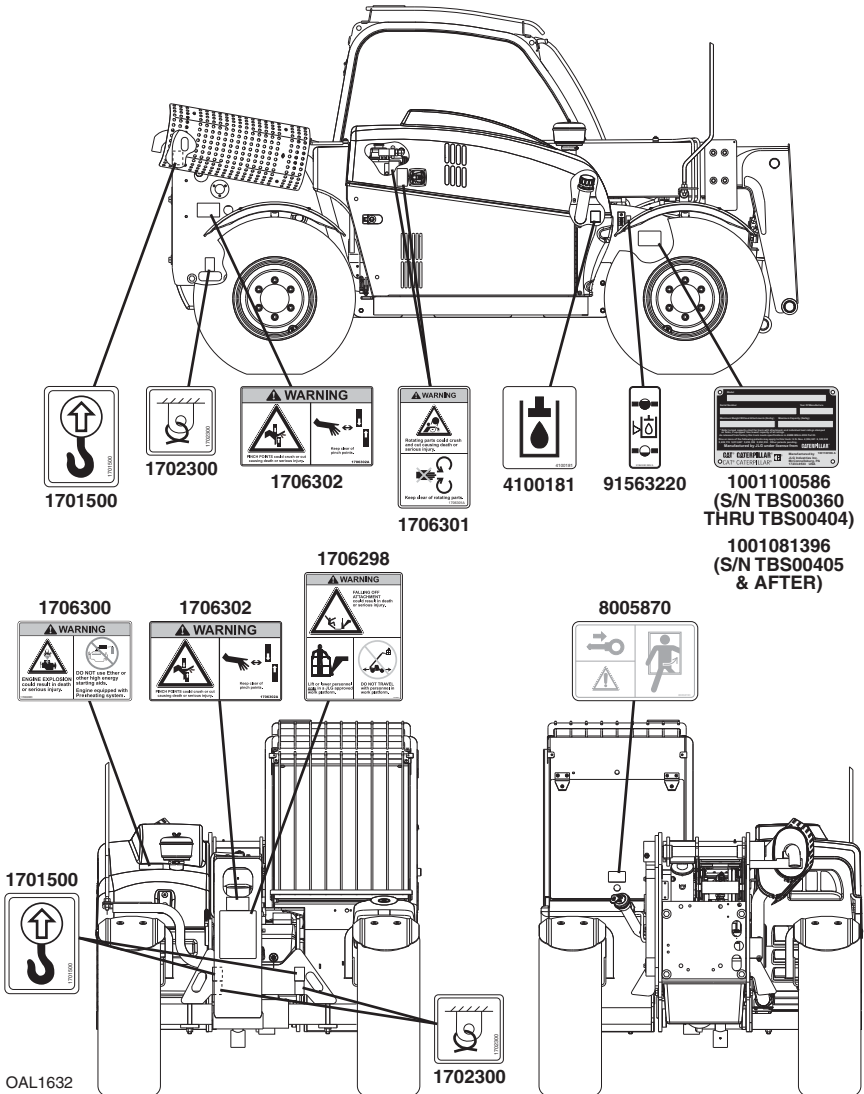

Section 2 - Pre-Operation and Inspection

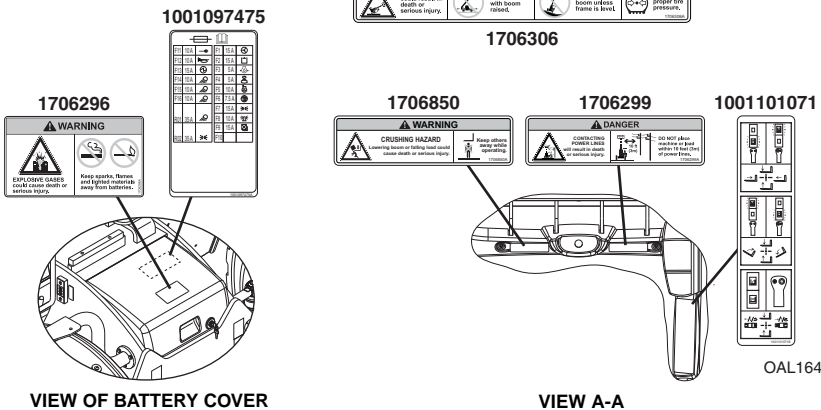
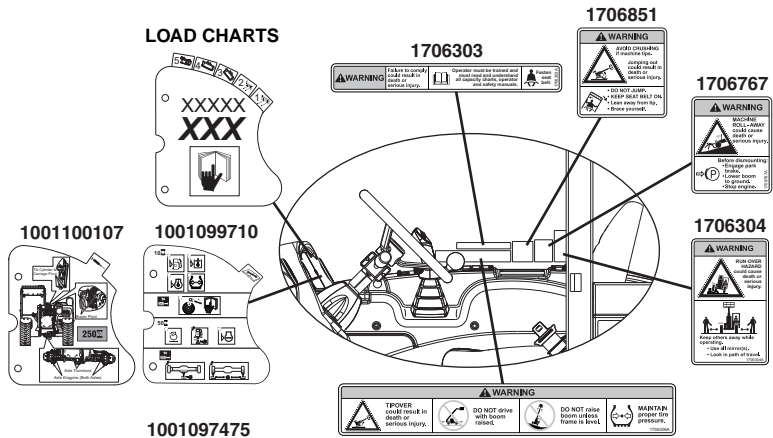
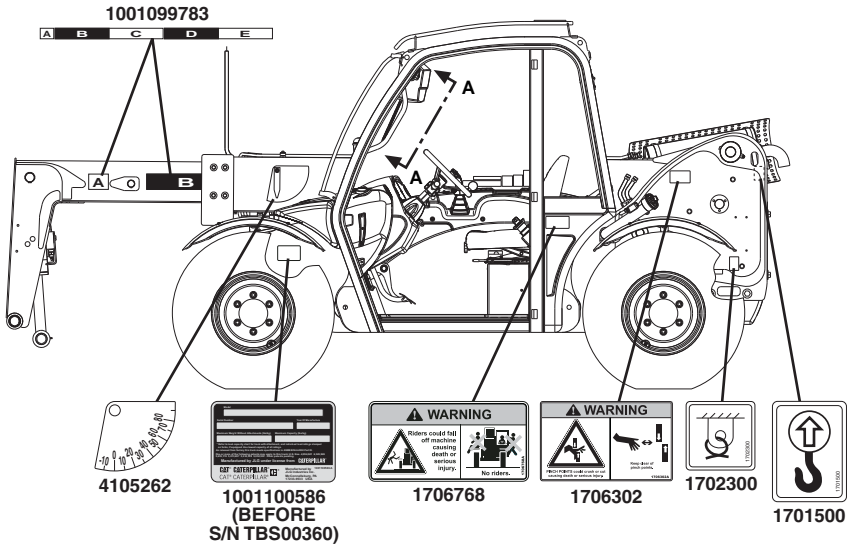

Section 2 - Pre-Operation and Inspection

ISO (CE & AUS) (ANSI, if equipped)

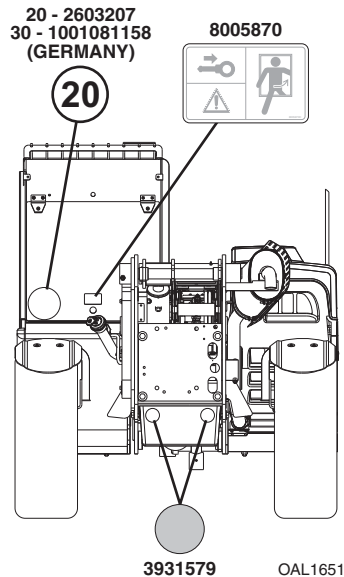
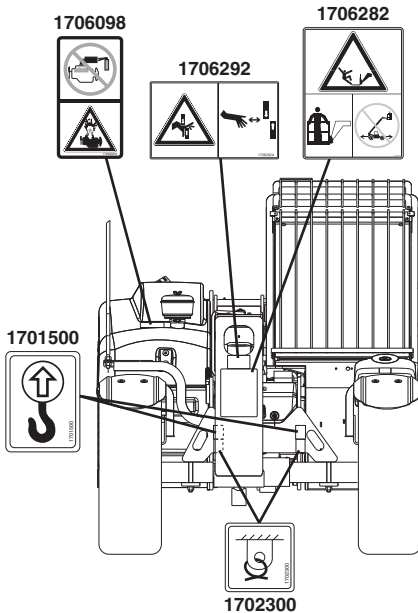
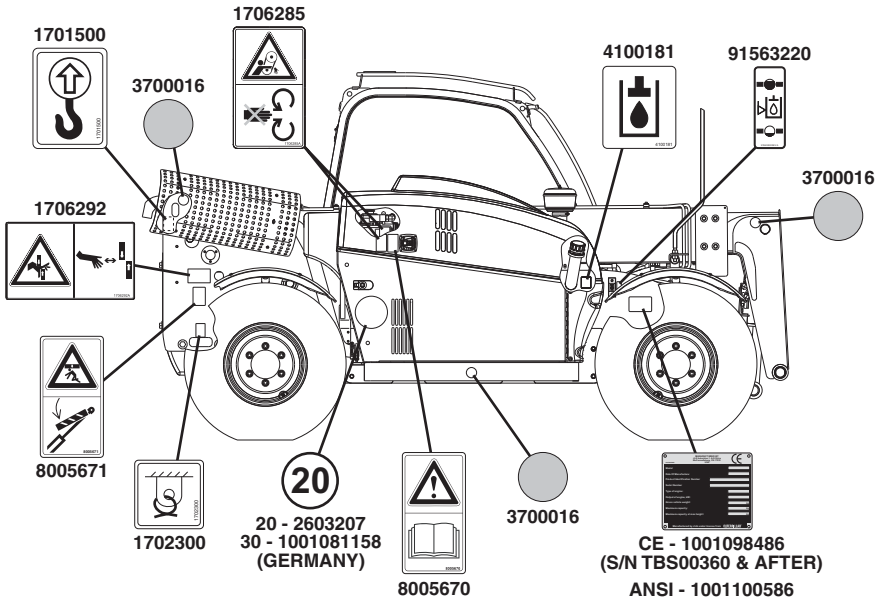

Section 2 - Pre-Operation and Inspection

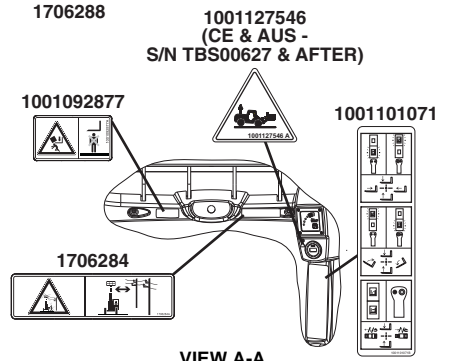
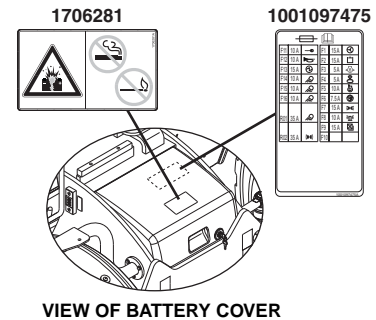
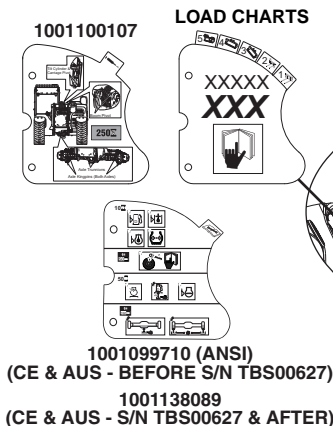
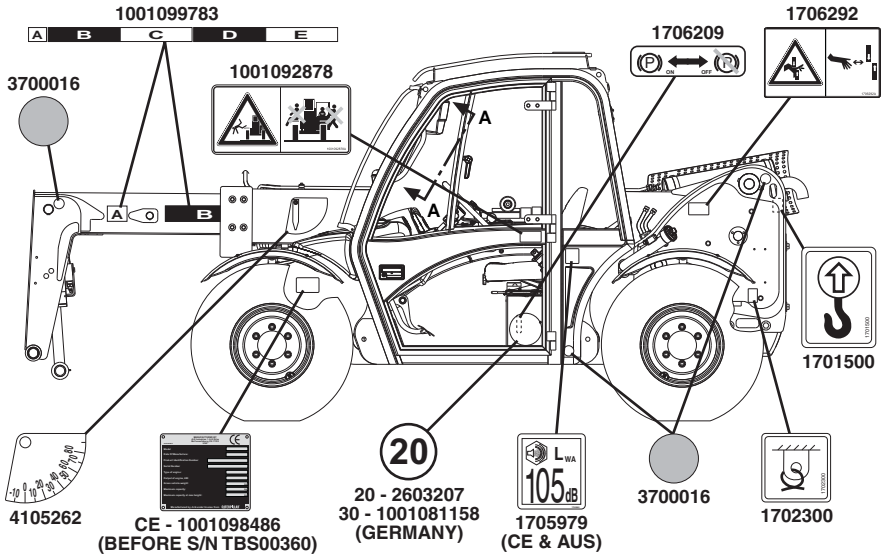

Section 2 - Pre-Operation and Inspection

2.3 WALK-AROUND INSPECTION

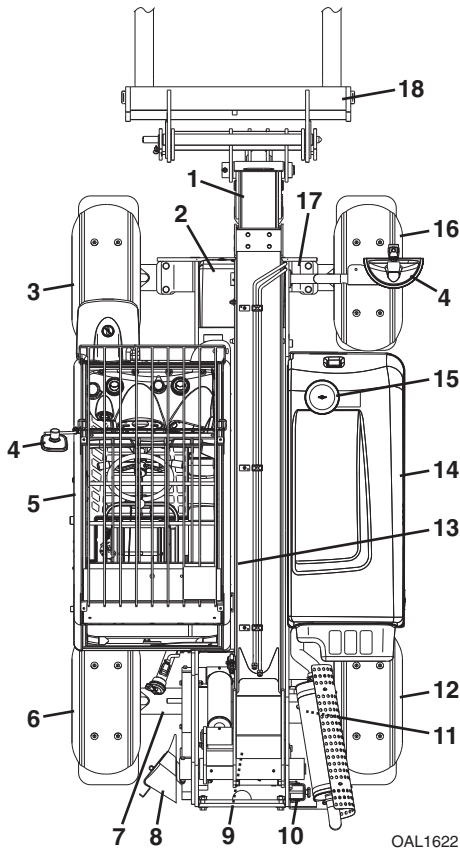

Begin your walk-around inspection at item 1, as noted below. Continue to your right (counterclockwise when viewed from top) checking each item in sequence.

INSPECTION NOTE: On all components, make sure there are no loose or missing parts, that they are securely fastened and no visible leaks or excessive wear exists in addition to any other criteria mentioned. Inspect all structural members including attachment for cracks, excessive corrosion and other damage.

1. Boom Sections and Lift, Tilt, Extend/Retract, Compensating (Slave) Cylinders -
 - Check front, top, side and rear wear pads for presence of grease.
 - Pivot pins secure; hydraulic hoses undamaged, not leaking.
2. Battery Compartment - Cables tight, no visible damage or corrosion. Cover properly secured.

Section 2 - Pre-Operation and Inspection

3. Wheel/Tire Assembly - Properly inflated and secured; no loose or missing lug nuts. Inspect for worn tread, cuts, tears or other discrepancies.
4. Mirrors - Clean and undamaged.
5. Cab and Electrical -
 - General appearance; no visible damage.
 - Window glass undamaged and clean.
 - Gauges, switches, joystick, foot controls and horn operational.
 - Check seat belt for damage, replace belt if frayed or cut webbing, damaged buckles or loose mounting hardware.
6. Wheel/Tire Assembly - Properly inflated and secured; no loose or missing lug nuts. Inspect for worn tread, cuts, tears or other discrepancies.
7. Rear Axle - Steer cylinders undamaged, not leaking; pivot pins secure; hydraulic hoses undamaged, not leaking.
8. Wheel Chock (if equipped) - See inspection note.
9. Main Control Valve - See inspection note.
10. Boom Prop (CE & AUS) - See inspection note.
11. LSI Sensor (CE & AUS) - See inspection note.
12. Wheel/Tire Assembly - Properly inflated and secured; no loose or missing lug nuts. Inspect for worn tread, cuts, tears or other discrepancies.
13. Boom Sensor (CE & AUS - S/N TBS00627 & After) - See inspection note.
14. Engine Compartment -
 - Drive belts, check condition and replace as required.
 - Engine mounts - See inspection note.
 - Engine cover properly secured.
15. Air Precleaner - Check and clean as required.
16. Wheel/Tire Assembly - Properly inflated and secured; no loose or missing lug nuts. Inspect for worn tread, cuts, tears or other discrepancies.
17. Front Axle - Steer cylinders undamaged, not leaking; hydraulic hoses undamaged, not leaking.
18. Attachment - Properly installed, see “*Attachment Installation*” on page 5-9.

Section 2 - Pre-Operation and Inspection

2.4 WARM-UP AND OPERATIONAL CHECKS

Warm-Up Check

During warm-up period, check:

1. Heater, defroster and windshield wiper (if equipped).
2. Check all lighting systems (if equipped) for proper operation.
3. Adjust mirror(s) for maximum visibility.



WARNING

CUT/CRUSH/BURN HAZARD. Keep engine cover closed while engine is running.

Operational Check

When engine warms, perform an operational check:

1. Service brake and parking brake operation.
2. Forward and reverse travel.
3. Steering in both directions with engine at low idle (steering lock to lock will not be reached). Check in each steering mode.
4. Horn and back-up alarm. Must be audible from inside operators cab with engine running.
5. All joystick functions - operate smoothly and correctly.
6. Perform any additional checks described in Section 8.

2.5 OPERATOR CAB

The telehandler is equipped with an open or enclosed ROPS/FOPS cab.



WARNING

Never operate telehandler unless the overhead guard and cab structure are in good condition. Any modification to this machine must be approved by JLG to assure compliance with ROPS/FOPS certification for this cab/machine configuration. If damaged, the **CAB CANNOT BE REPAIRED**. It must be **REPLACED**.

Section 2 - Pre-Operation and Inspection

2.6 WINDOWS

Keep all windows and mirrors clean and unobstructed.

Cab Door Window (if equipped)

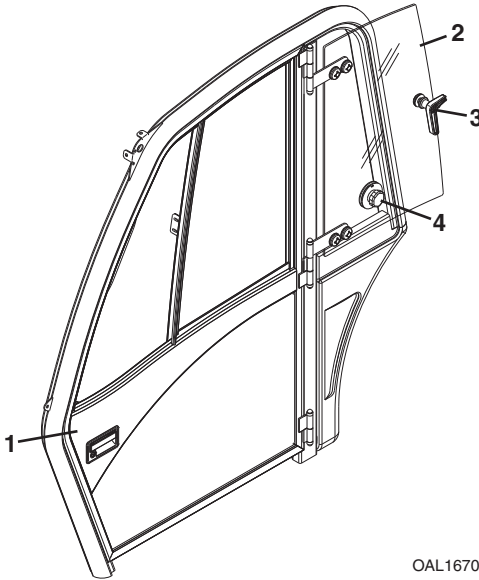

OAL1670

- Cab door (1) must be closed during operation.
- During operation the cab door window (2) must either be latched open or closed.
- Open the cab door window using lever (3) and secure it in the latch.
- Rotate knob (4) inside the cab or outside the cab to unlatch the window.

Rear Window

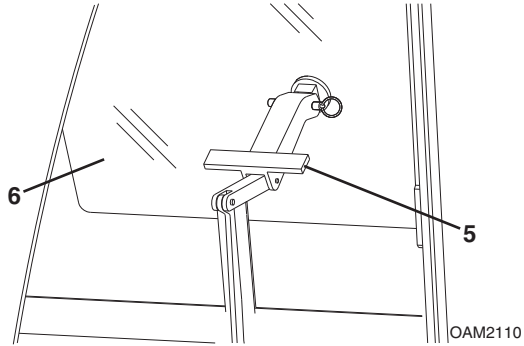

- Lift lever (5) and push to open rear window (6).
- Lift lever and pull to close.

This Page Intentionally Left Blank

SECTION 3 - CONTROLS AND INDICATORS

3.1 GENERAL

This section provides the necessary information needed to understand control functions.

Note: *The manufacturer has no direct control over machine application and operation. The user and operator are responsible for conforming with good safety practices.*

Section 3 - Controls and Indicators

3.2 CONTROLS

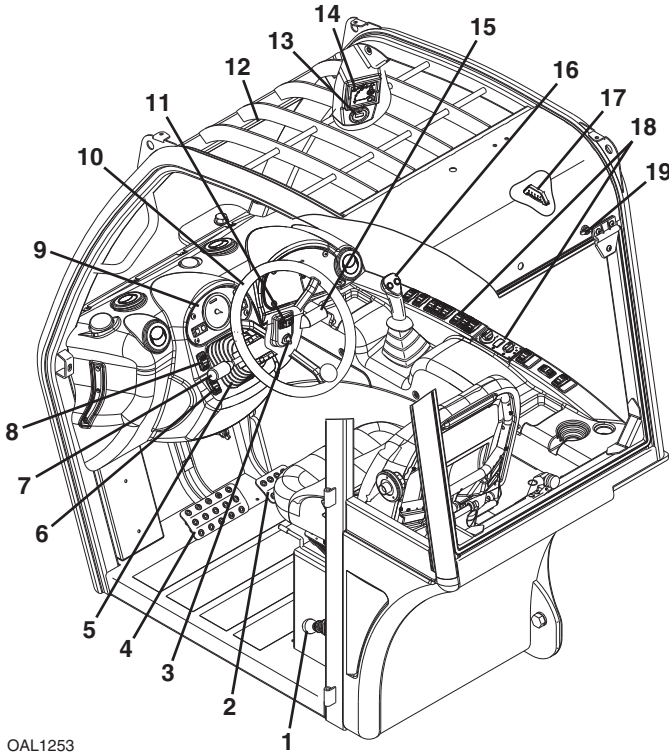

OAL1253

1. Park Brake Lever (CE & AUS): See page 3-4.
2. Accelerator Pedal: Pressing down the pedal increases engine and hydraulic speed.
3. Ignition Switch: Key activated. See page 3-6.
4. Service Brake Pedal: The further the pedal is depressed, the slower the travel speed.
5. Tilt Steering Column (if equipped): See page 3-13.
6. Quick Coupler Switch (if equipped): Used in conjunction with the joystick to hydraulically lock or unlock an attachment.
7. Transmission Control Lever: See page 3-7.
8. Park Brake Switch (ANSI): See page 3-4.
LSI Override Switch (CE & AUS): See page 3-11.
9. Instrument Panel: See page 3-12.

Section 3 - Controls and Indicators

10. Steering Wheel: Turning the steering wheel to the left or right steers the machine in the corresponding direction. Three steering modes are available. See “*Steer Modes*” on page 3-19.
11. Horn Button: Depress button to sound horn.
12. Frame Level Indicator: Enables operator to determine the left to right level condition of the telehandler.
13. Speedometer (CE & AUS): Displays speed of machine travel.
14. LSI Indicator (CE & AUS): See page 3-8.
15. Accessory Control Lever (if equipped): See page 3-18.
16. Joystick: See page 3-14.
17. Longitudinal Level Indicator (AUS): Enables operator to determine the front to back level condition of the telehandler.
18. Right Hand Console: See page 3-16.
19. Power Outlet: 12V receptacle.

Section 3 - Controls and Indicators

Park Brake

Park Brake Switch (ANSI)

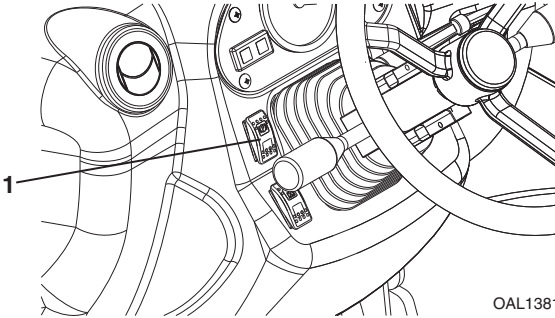

Park brake switch (1) controls the application and release of the park brake. Indicator light on switch illuminates to indicate brake is applied.

- Depress top of switch to engage park brake. With park brake applied, transmission will not engage forward or reverse.
- Depress bottom of switch to disengage park brake.



WARNING

MACHINE ROLL-AWAY HAZARD. Always move park brake switch to "ON" position, lower boom to ground and stop engine before leaving cab.



WARNING

CRUSH HAZARD. Turning engine off applies the park brake. Applying park brake or turning engine off while traveling will cause unit to stop abruptly and could cause load loss. To stop the machine in an emergency, either apply the park brake or turn off engine.

Park Brake Lever (CE & AUS)

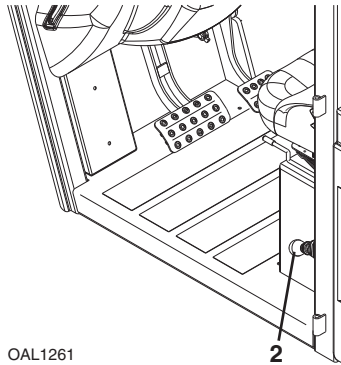

Park brake lever (2) controls the application and release of the park brake.

- Pull lever up to engage park brake. With park brake applied, transmission will not engage forward or reverse.
- Lift detent ring and push lever down to disengage park brake.



WARNING

MACHINE ROLL-AWAY HAZARD. Always move park brake lever to "ON" position, lower boom to ground and stop engine before leaving cab.



WARNING

CRUSH HAZARD. Turning engine off applies the park brake. Applying park brake or turning engine off while traveling will cause unit to stop abruptly and could cause load loss. To stop the machine in an emergency, either apply the park brake or turn off engine.

Parking Procedure

1. Using service brake, stop telehandler in an appropriate parking area.
2. Follow "Shut-Down Procedure" on page 4-3.

Section 3 - Controls and Indicators

Ignition

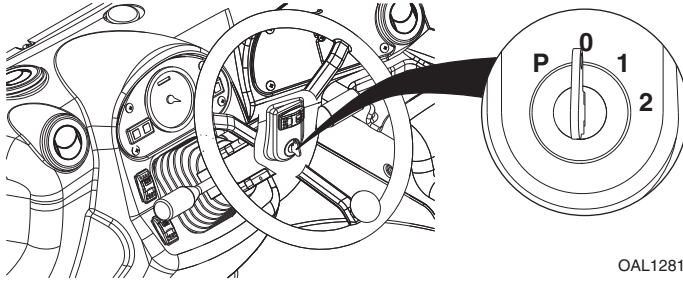

- Position **P**: Engine preheat at temperatures below 32° F (0° C). Hold in position for approximately 10 seconds.
- Position **0**: Engine off.
- Position **1**: Voltage available for all electrical functions. Prohibits rotating switch to position 2 in the event the engine does not start. Rotate key to position 0 then back to position 2 to re-engage starter.
- Position **2**: Engine start.

Transmission Control Lever

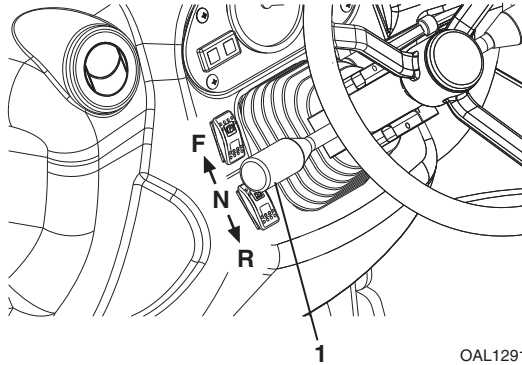

OAL1291

Transmission control lever (1) engages forward or reverse travel.

- Lift and push lever forward for forward travel; lift and pull lever rearward for reverse travel. Move lever to centered position for neutral.
- When traveling in reverse, the back-up alarm will automatically sound.
- Drive in reverse and turn only at slow rates of speed.
- Do not increase engine speed with the transmission in forward or reverse and the service brake depressed in an attempt to get quicker hydraulic performances. This could cause unexpected machine movement.



WARNING

TIP OVER/CRUSH HAZARD. Bring telehandler to a complete stop before shifting transmission control lever. A sudden change in direction of travel could reduce stability and/or cause load to shift or fall.

Section 3 - Controls and Indicators

Load Stability Indicator - LSI (CE & AUS)

WARNING

TIP OVER HAZARD. The LSI considers only longitudinal stability limitations, observe all operating parameters. Failure to follow operating parameters of the telehandler could damage the equipment and/or cause tip over.

Before S/N TBS00627

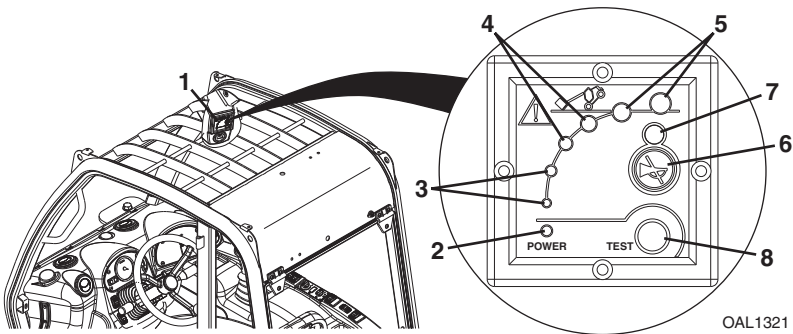

The LSI (1) provides visual and audible indication of forward stability limitations when machine is static on firm, level surface.

- Green LED (2) will illuminate when LSI power is on.
- When approaching forward stability limitations LEDs progressively illuminate, green (3), then yellow (4) and finally red (5).
- The warning buzzer sounds as the first red LED illuminates.
- As the telehandler reaches forward stability limitations and the second red LED illuminates, the automatic function cut-out is activated. Certain functions are disabled (i.e. boom lift, extend, etc). Retract boom to re-enable functions.
- Press button (6) to disable the warning buzzer. When disabled, yellow LED (7) will illuminate. If last red LED illuminates, disable button is overridden and warning buzzer sounds.
- Test LSI (8) at the beginning of each work shift. See Section 8 - Additional Checks.

S/N TBS00627 & After

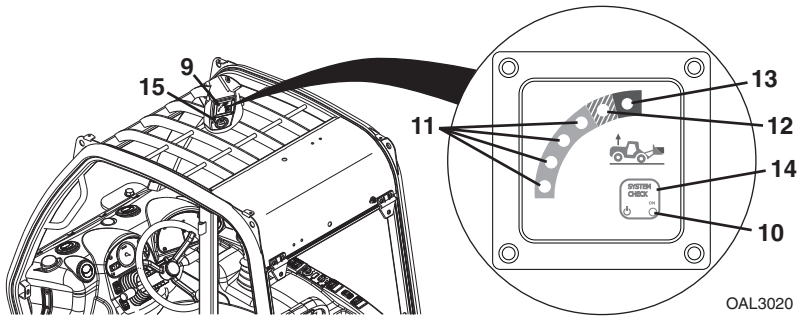

The LSI (9) provides visual and audible indication of forward stability limitations when machine is static on firm, level surface.

- Green LED (10) will illuminate when LSI power is on.
- When approaching forward stability limitations LEDs progressively illuminate, green (11), then orange (12) and finally red (13).
- If the red LED illuminates the warning buzzer also sounds.

The LSI has two modes:

Active Mode (CE & AUS)

- As the telehandler reaches forward stability limitations and the red LED (13) illuminates, the automatic function cut-out is activated. All boom functions are disabled except for boom retract (CE & AUS) and boom lift (CE). Retract boom to re-enable functions.
- In some instances the LSI system may slow down or stop boom functions if operated close to forward stability limitations. When LEDs begin to flash, certain functions can not be operated. Retract boom and/or return the joystick to neutral position for a short period to allow system to reset and LEDs to stop flashing before proceeding with operation.

Passive Mode (CE)

- The orange LED (15) illuminates when the following occurs:
 - The park brake is not applied and transmission control lever is in the forward or reverse position.
- When approaching forward stability limitations, visual and audible indication is provided and the automatic function cut-out and/or slow down feature is disabled.

Section 3 - Controls and Indicators

- Travel in accordance with the requirements set forth in Section 1 - General Safety Practices.
- Test LSI (14) at the beginning of each work shift. See Section 8 - Additional Checks.
- When placing a load, ensure axles are not fully steered in either direction.



WARNING

TIP OVER HAZARD. If the green, orange and red LEDs flash and warning buzzer sounds, retract and lower boom immediately. Determine cause and correct before continued use.

LSI Override Switch (CE & AUS)

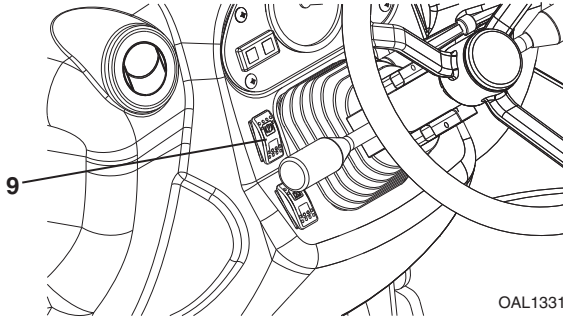

The LSI override switch (9) momentarily disables the automatic function cut-out.

- **Before S/N TBS00627**

CE - Depress and hold top of switch while operating joystick to momentarily disable the automatic function cut-out.

AUS - Depress and hold top of switch up to 30 seconds while operating joystick to momentarily disable the automatic function cut-out.

S/N TBS00627 & After

Depress and hold top of switch up to 30 seconds while operating joystick to momentarily disable the automatic function cut-out.

- Release switch to re-enable the automatic function cut-out.



WARNING

TIP OVER HAZARD. Exceeding lift capacity of the telehandler could damage the equipment and/or cause tip over.

Section 3 - Controls and Indicators

Instrument Panel

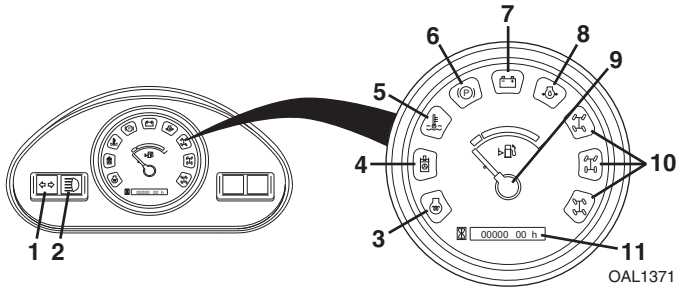

1. Turn Signal Indicator (if equipped): Illuminates when turn signal is active.
2. High Beam Indicator (if equipped): Illuminates when high beam lights are on.
3. Engine Preheat Indicator: Illuminates with ignition key in position P. At temperatures below 0° C (32° F), do not start until engine is preheated.
4. Hydraulic Steering Pressure Indicator (CE & AUS): Illuminates when steer pressure is too low. If light remains on, shut-down engine.
5. Engine Coolant Temperature Indicator: Illuminates when engine coolant temperature is too high. Stop and idle engine, allowing time to cool and shut-down.
6. Park Brake Indicator: Illuminates when park brake is applied.
7. Battery Charge Indicator: Illuminates to indicate batteries at low charge or a weak or improperly functioning charging system.
8. Engine Oil Pressure Indicator: Illuminates when engine oil pressure is too low. Shut-down engine immediately.
9. Fuel Gauge: Indicates amount of fuel in fuel tank.
10. Steer Mode Indicators: Illuminates active steering mode.
11. Hourmeter: Records and indicates engine operating hours.

NOTICE

EQUIPMENT DAMAGE. When a red indicator illuminates (except park brake), immediately bring machine to a stop, lower boom and attachment to ground and stop the engine. Determine cause and correct before continued use.

Steering Column Adjuster (if equipped)

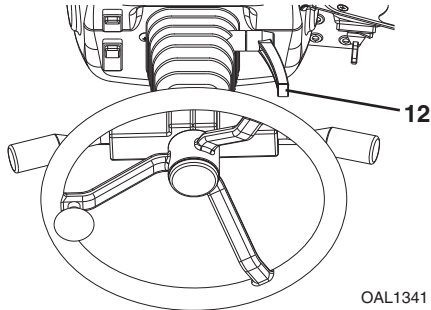

The steering column adjustment lever (12) controls the steering column position.

- Follow “*Shut-Down Procedure*” on page 4-3.
- Turn lever counterclockwise to unlock.
- Place steering column in the desired position.
- Turn lever clockwise to lock steering wheel.



WARNING

TIP OVER/CRUSH HAZARD. Bring telehandler to a complete stop and shutdown engine before adjusting steering column. A sudden change in direction of travel could reduce stability and/or cause load to shift or fall.

Section 3 - Controls and Indicators

Joystick

Refer to lift/loader joystick pattern switch (see page 3-17) on right hand console to verify control pattern before operating.

Lift Joystick Pattern

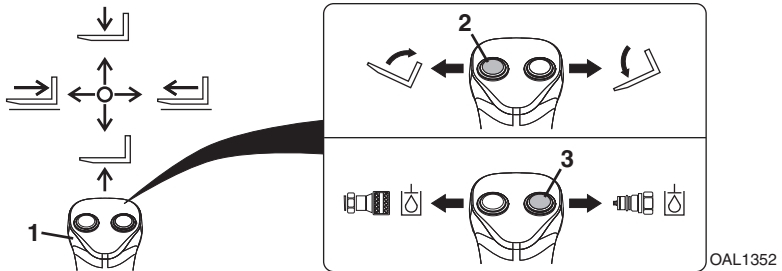

The joystick (1) controls the boom, attachment tilt and auxiliary hydraulic functions.

Boom Functions

- Move the joystick back to lift boom; move joystick forward to lower boom; move joystick right to extend boom; move joystick left to retract boom.
- The speed of boom functions depends upon the amount of joystick travel in corresponding direction. Increasing engine speed will also increase function speed.
- For two simultaneous boom functions, move the joystick between quadrants. For example; moving the joystick forward and to the left will lower and retract boom simultaneously.

Attachment Function

Tilt control is enabled by the left button (2).

- While depressing button move joystick right to tilt down; move joystick left to tilt up.

Auxiliary Hydraulic Functions

The right button (3) enables function of attachments that require hydraulic supply for operation. See Section 5 - Attachments and Hitches for approved attachments and control instructions.



WARNING

TIP OVER/CRUSH HAZARD. Rapid, jerky operation of controls will cause rapid, jerky movement of the load. Such movements could cause the load to shift or fall or could cause the machine to tip over.

Loader Joystick Pattern

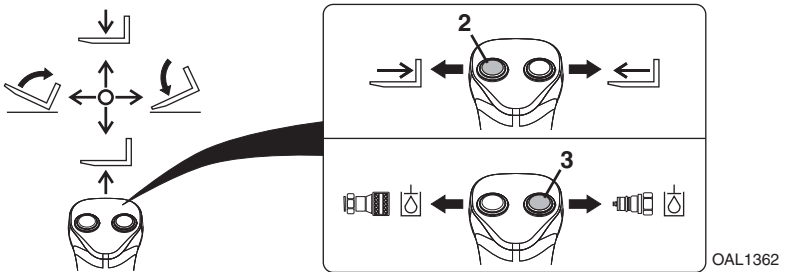

The joystick (1) controls the boom, attachment tilt and auxiliary hydraulic functions.

Boom Functions

- Move the joystick back to lift boom; move joystick forward to lower boom
- Extend/retract is enabled by the left button (2). While depressing button move joystick right to extend boom; move joystick left to retract boom.
- The speed of boom functions depends upon the amount of joystick travel in corresponding direction. Increasing engine speed will also increase function speed.
- For two simultaneous boom functions, move the joystick between quadrants. For example; moving the joystick forward and to the left will lower boom and tilt attachment up simultaneously.

Attachment Function

Tilt control is enabled by the joystick.

- Move joystick right to tilt down; move joystick left to tilt up.

Auxiliary Hydraulic Functions

The right button (3) enables function of attachments that require hydraulic supply for operation. See Section 5 - Attachments and Hitches for approved attachments and control instructions.



WARNING

TIP OVER/CRUSH HAZARD. Rapid, jerky operation of controls will cause rapid, jerky movement of the load. Such movements could cause the load to shift or fall or could cause the machine to tip over.

Section 3 - Controls and Indicators

Right Hand Console

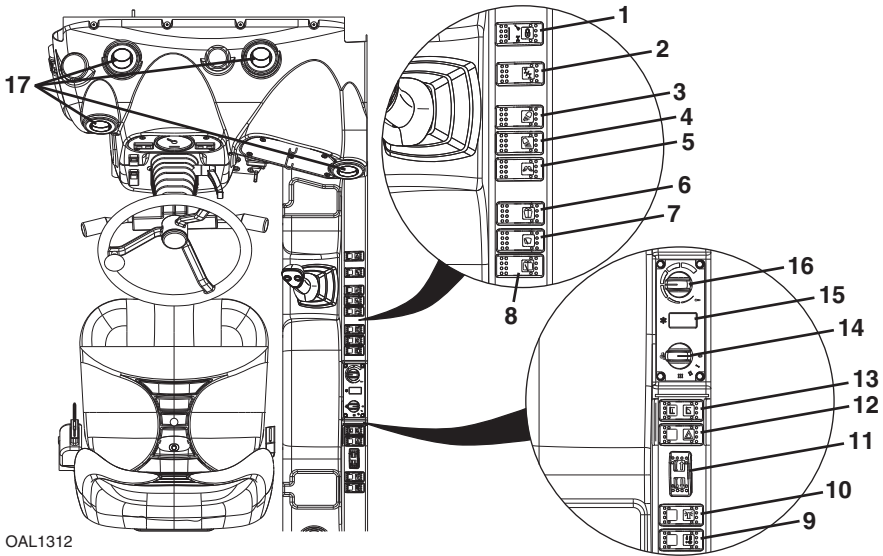

OAL1312

1. Road Use Operation Switch (CE): Depress right side of switch to lock steer mode and joystick functions.

Note: Activate this function before traveling on public roads. See “Road Operation (CE)” on page 4-10.

2. Steer Select Switch: Three position switch. Three steer modes available: 4-Wheel Circle Steer, 2-Wheel Front Steer and 4-Wheel Crab Steer. See page 3-19.
3. Boom Work Light Switch (if equipped): On/Off switch.
4. Front Work Light Switch (if equipped): On/Off switch.
5. Rear Work Light Switch (if equipped): On/Off switch.
6. Front Wiper Switch (if equipped): Three position switch. Depress right side of switch for fast speed; middle position for slow speed; left side to turn off.
7. Front Windshield Washer Switch (if equipped): Depress right side of switch and hold to activate washer fluid.
8. Skylight and Rear Wiper Switch (if equipped): Three position switch. Move switch to middle position to turn wipers on; depress and hold right side of switch to activate washer fluid; depress left side of button to turn off.
9. Auxiliary Hydraulic Pressure Relief Switch: Relieves auxiliary hydraulic circuit pressure. See page 5-14.

Section 3 - Controls and Indicators

10. Beacon Light Switch (if equipped): On/Off switch.
11. Front/Rear Auxiliary Hydraulic Switch (if equipped): Depress front of switch to enable front auxiliary hydraulics. Depress back of switch to enable rear auxiliary hydraulics.
12. Hazard Light Switch (if equipped): On/Off switch.
13. Lift/Loader Joystick Pattern Switch: Depress left side of switch to activate lift joystick pattern. Depress right side of switch to activate loader joystick pattern.

Heater and Air Conditioning Controls (if equipped)

14. Fan Speed Switch (if equipped): Four position rotary switch.
15. Air Conditioning Switch (if equipped): On/Off switch.
16. Temperature Control Switch (if equipped): Adjustable rotary switch.
17. Air Louver (if equipped): Four individually adjustable air louvers.

Section 3 - Controls and Indicators

Accessory Control Lever (if equipped)

The accessory control lever (1) operates the turn signals, parking lights and headlights.

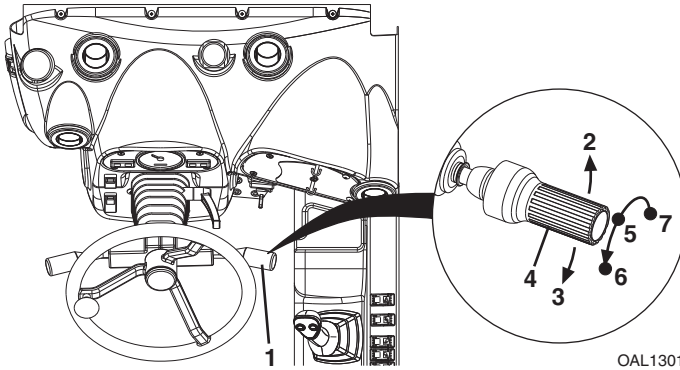

OAL1301

Turn Signals

- Push the lever forward (2) to activate the left turn signal.
- Pull the lever back (3) to activate the right turn signal.
- The lever must be manually returned to the center position to deactivate either turn signal. The lever will not cancel automatically after a turn.

Parking Lights and Headlights

- Turn the twist grip (4) of the lever counterclockwise to the first position (5) to turn on the parking lights.
- Turn the twist grip to the second position (6) to turn on the headlights.
- Raise/lower the lever to switch between low and high beam.
- Turn the twist grip clockwise to the OFF position (7) to turn all lights off.

3.3 STEER MODES

Three steer modes are available for operator use.

2-Wheel Front Steer

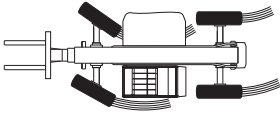

OAL2030

4-Wheel Circle Steer

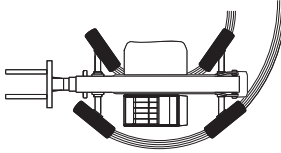

4-Wheel Crab Steer

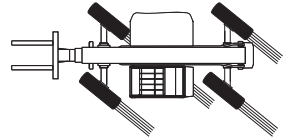

Note: 2-Wheel Front Steer mode is required for travel on public roads.

Steer Mode Change

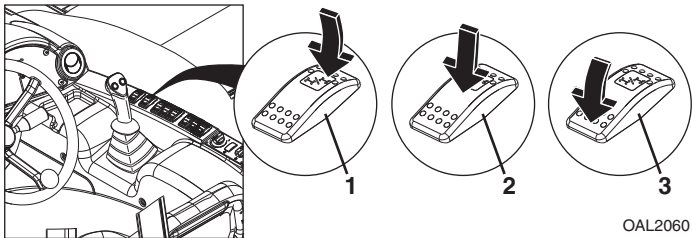

1. Bring machine to a stop using service brake while either circle steer mode (1) or crab steer mode (3) is selected.

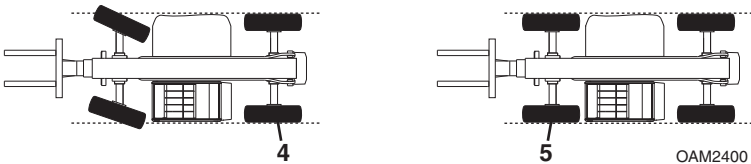

2. Turn the steering wheel until the left rear wheel (4) is aligned with the side of the machine.
3. Select front steer mode (2).
4. Turn the steering wheel until the left front wheel (5) is aligned with the side of the machine.
5. Wheels are now aligned. Select desired steer mode.

Section 3 - Controls and Indicators

3.4 OPERATOR SEAT

Adjustments

Prior to starting engine adjust seat for position and comfort.

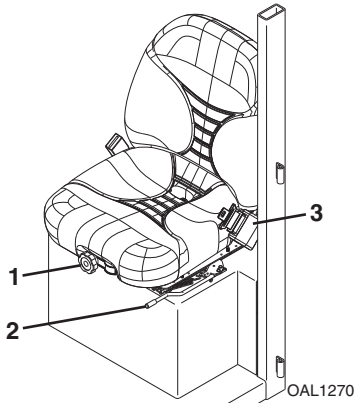

1. **Suspension:** Use knob to adjust suspension to the appropriate setting. Turn clockwise to increase stiffness. Turn counterclockwise to reduce stiffness.
2. **Fore/Aft:** Pull up on handle to move seat fore and aft.
3. **Seat Belt:** Always fasten seat belt during operation. If required, a 3 in (76 mm) seat belt is available.

Seat Belt



Fasten seat belt as follows:

1. Grasp both free ends of the belt making certain that belt webbing is not twisted or entangled.
2. With back straight in the seat, couple the retractable end (male end) of the belt into the receptacle (buckle) end of the belt.
3. With belt buckle positioned as low on the body as possible, pull the retractable end of the belt away from the buckle until it is tight across the lap.
4. To release belt latch, depress red button on the buckle and pull free end from buckle.

Section 3 - Controls and Indicators

3.5 BOOM ANGLE AND EXTENSION INDICATORS

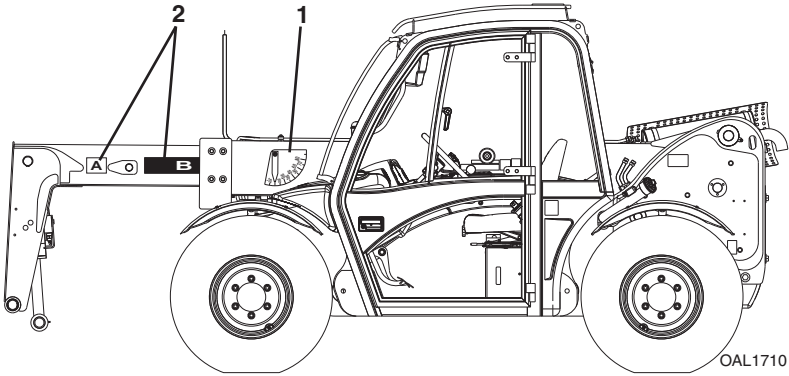

- The boom angle indicator (1) is located on the left side of the boom. Use this indicator to determine the boom angle when using the load chart (see *“Use of the Load Chart”* on page 5-5).
- Boom extension indicators (2) are located on the left side of the boom. Use these indicators to determine boom extension when using the load chart (see *“Use of the Load Chart”* on page 5-5).

SECTION 4 - OPERATION

4.1 ENGINE

Note: Refer to Engine Operation & Maintenance Manual for additional information.

Starting the Engine

This machine can be operated under normal conditions in temperatures of 0°F to 104°F (-20°C to 40°C). Consult the local Caterpillar dealer for operation outside this range or under abnormal conditions.

1. Make sure all controls are in “Neutral” and all electrical components (lights, heater, defroster, etc.) are turned off. Apply park brake.
2. If the temperature is below 32° F (0° C), turn the ignition switch to “position P” and hold for approximately 10 seconds.
3. Turn ignition switch to “position 2” to engage starting motor. Release key immediately when engine starts. If engine fails to start within 20 seconds, release key and allow starting motor to cool for a few minutes before trying again.
4. After engine starts, observe indicators. If indicators remain on for more than five seconds, stop engine and determine cause before restarting engine.
5. Warm up engine at approximately 1/2 throttle.

Note: Engine will not start unless transmission control lever is in “Neutral” and park brake is applied.



WARNING

ENGINE EXPLOSION. Do not spray ether into air intake for cold weather starting.



WARNING

UNEXPECTED MOVEMENT HAZARD. Always ensure that transmission control lever is in neutral and the service brake is applied before releasing park brake. Releasing park brake in either forward or reverse could cause the machine to move abruptly, causing an accident.

Section 4 - Operation

Battery Boosted Starting



OW0530

If battery-boost starting (jump-start) is necessary, proceed as follows:

- Never allow vehicles to touch.
- Connect the positive (+) jumper cable to positive (+) post of discharged battery.
- Connect the opposite end of positive (+) jumper cable to positive (+) post of booster battery.
- Connect the negative (-) jumper cable to negative (-) post on booster battery.
- Connect opposite end of negative (-) jumper cable to ground point on machine away from discharged battery.
- Follow standard starting procedures.
- Remove cables in reverse order after machine has started.



WARNING

BATTERY EXPLOSION HAZARD. Never jump start or charge a frozen battery as it could explode. Keep sparks, flames and lighted smoking materials away from the battery. Lead acid batteries generate explosive gases when charging. Wear safety glasses.

Normal Engine Operation

- Observe instrument panel frequently to be sure all systems are functioning properly.
- **Be alert for unusual noises or vibration.** When an unusual condition is noticed, park machine in safe position and perform shut-down procedure. Report condition to your supervisor or local Caterpillar dealer.
- **Avoid prolonged idling.** If the engine is not being used, turn it off.

Shut-Down Procedure

When parking the telehandler, park in a safe location on flat level ground and away from other equipment and/or traffic lanes.

1. Apply the park brake.
2. Shift the transmission to "Neutral."
3. Lower forks or attachment to the ground.
4. Operate engine at low idle for 3 to 5 minutes. **DO NOT over rev engine.**
5. Shut off engine and remove ignition key.
6. Exit telehandler properly.
7. Turn off electrical master switch (if equipped).
8. Block wheels (if necessary).

Section 4 - Operation

4.2 OPERATING WITH A NON-SUSPENDED LOAD

Lift Load Safely

- You must know the weight and load center of every load you lift. If you are not sure of the weight and load center, check with your supervisor or with the supplier of the material.



WARNING

TIP OVER HAZARD. Exceeding lift capacity of the telehandler could damage the equipment and/or cause tip over.

- Know the rated load capacities (see Section 5) of the telehandler to determine the operating range in which you can safely lift, transport and place a load.

Before Picking Up a Load

- Note the conditions of the terrain. Adjust travel speed and reduce amount of load if conditions warrant.
- Avoid lifting double-tiered loads.
- Make sure load is clear of any adjacent obstacles.
- Adjust spacing of forks so they engage the pallet or load at maximum width. See “*Adjusting/Moving Forks*” on page 5-15.
- Approach load slowly and squarely with fork tips straight and level. **NEVER** attempt to lift a load with just one fork.
- **NEVER** operate telehandler without a proper and legible load chart in the operator cab for the telehandler/attachment combination you are using.

Transporting a Load



- After engaging the load and resting it against the backrest, tilt the load back to position it for travel. Travel in accordance with the requirements set forth in Section 1 - General Safety Practices and Section 5 - Attachments and Hitches.
- Maintain a slow speed when transporting a load.

Leveling Procedure

1. Position machine in best location to lift or place load.
2. Apply parking brake and move transmission control lever to NEUTRAL.
3. Observe level indicator to determine whether machine must be leveled prior to lifting load.
4. Move boom/attachment to 4 ft (1,2 m) off ground.
(AUS - Move boom so forks are no more than 300 mm (11.8 in) above ground surface.)

Important things to remember:

- Never raise the boom/attachment more than 4 ft (1,2 m) above ground unless telehandler is level.
(AUS - Never raise the forks more than 300 mm (11.8 in) above ground surface unless telehandler is level.)
- The combination of side tilt and load could cause the telehandler to tip over.

Section 4 - Operation

Placing a Load

Before placing any load be sure that:

- The landing point can safely support the weight of the load.
- The landing point is level; front to back and side to side.
- Use the load chart to determine safe boom extension range. See *“Use of the Load Chart”* on page 5-5.
- Align forks at the level load is to be placed, then extend boom slowly until load is just above area where it is to be placed.
- Lower the boom until the load rests in position and the forks are free to retract.

Disengaging a Load

Once the load has been placed safely at the landing point, proceed as follows:

1. With the forks free from the weight of the load, the boom can be retracted and/or the telehandler can be backed away from under the load if surface will not change level condition of telehandler.
2. Lower the carriage.
3. The telehandler can now be driven from the landing location to continue work.

4.3 OPERATING WITH A SUSPENDED LOAD (ANSI & CE)

Lift Load Safely

- You must know the weight and load center of every load you lift. If you are not sure of the weight and load center, check with your supervisor or with the supplier of the material.



WARNING

TIP OVER HAZARD. Exceeding lift capacity of the telehandler could damage the equipment and/or cause tip over.

- Know the rated load capacities (refer to Section 5) of the telehandler to determine the operating range in which you can safely lift, transport and place a load.

Picking Up a Suspended Load

- Note the conditions of the terrain. Adjust travel speed and reduce amount of load if conditions warrant.
- Avoid lifting double-tiered loads.
- Make sure load is clear of any adjacent obstacles.
- **NEVER** operate telehandler without a proper and legible load chart in the operator cab for the telehandler/attachment combination you are using.
- Only use approved lifting devices rated for the lifting of the load.
- Identify the proper lifting points of the load, taking into consideration the center of gravity and load stability.
- Ensure to always properly tether loads to restrict movement.
- Refer to *“Use of the Load Chart”* on page 5-5 for proper lifting guidelines in addition to the appropriate load chart in the operator cab.

Section 4 - Operation

Transporting a Suspended Load



OZ3160



OW0130

- Travel in accordance with the requirements set forth in Section 1 - General Safety Practices and Section 5 - Attachments and Hitches.
- For additional requirements, refer to the appropriate load chart in the operator cab.

Important things to remember:

- Ensure the boom is fully retracted.
- Never raise the load more than 11.8 in (300 mm) above ground surface or the boom more than 45°.
- The combination of frame leveling and load could cause the telehandler to tip over.
- The guide men and operator must remain in constant communication (verbal or hand) and be in visual contact with the operator at all times.
- Never place the guide men between the suspended load and the telehandler.
- Only transport the load at walking speed, 0.9 mph (0.4 m/s), or less.

Leveling Procedure

1. Position machine in best location to lift or place load.
2. Apply parking brake and move transmission control lever to NEUTRAL.
3. Observe level indicator to determine whether machine must be leveled prior to lifting load.
4. Move boom so load is no more than 11.8 in (300 mm) above ground surface and boom/or boom is raised no more than 45°.

Placing a Suspended Load

Before placing any load be sure that:

- The landing point can safely support the weight of the load.
- The landing point is level; front to back and side to side.
- Use the load chart to determine safe boom extension range. “*Use of the Load Chart*” on page 5-5
- Align load at the level load is to be placed, then position boom slowly until load is just above area where it is to be placed.
- Ensure that the guide men and operator remain in constant communication (verbal or hand) when placing the load.

Disengaging a Suspended Load

- Never place the guide men between the suspended load and the telehandler.
- Once at the destination of the load, ensure to bring the telehandler to a complete stop and apply the park brake prior to disengagement of the lifting devices and tethers.

Section 4 - Operation

4.4 ROAD OPERATION (CE)

1. Preparation
 - a. Remove load from attachment.
 - b. Remove any large amounts of dirt from machine.
 - c. Check lights and mirrors and adjust if necessary.
 - d. Safety equipment to be carried: Warning Triangle, First Aid Kit and Wheel Chock.
2. Lower boom. Front edge of attachment should be approximately 12-16 in (30-40 cm) above the ground.
3. Fully tilt attachment back.
4. Place protective shield over front bucket edge: remove or reposition carriage forks toward the machine and secure to the carriage.

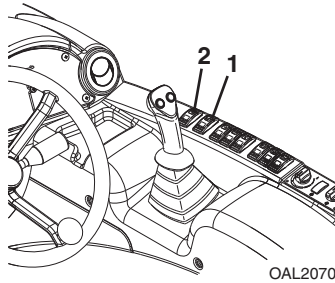

5. Change steer mode to front wheel steering (1). See “Steer Mode Change” on page 3-19.
6. Activate road use operation switch (2) to lock steer mode and joystick controlled functions.
7. Machine is now ready for road operation.

Note: Be sure to follow all local and federal/provincial traffic regulations.

4.5 LOADING AND SECURING FOR TRANSPORT

Tiedown

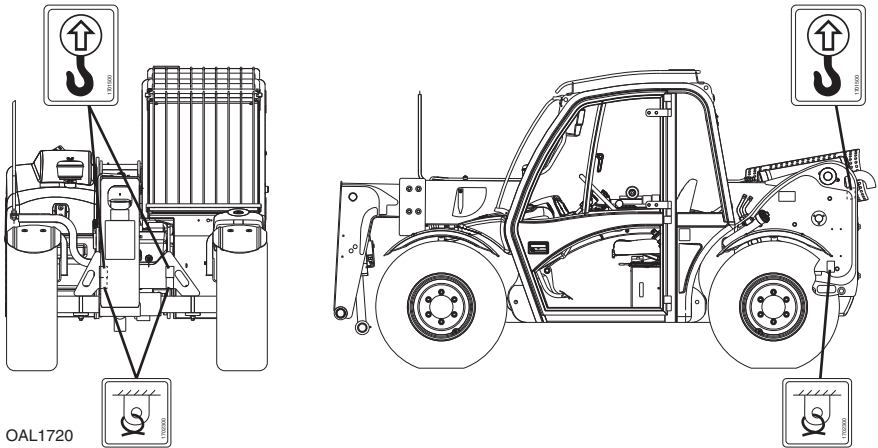

1. Using a spotter, load the telehandler with boom as low as possible.
2. Once loaded, apply parking brake and lower boom until boom or attachment is resting on deck. Move all controls to "Neutral," stop engine and remove ignition key.
3. Secure machine to deck by passing chains through the designated tie down points as shown in the figure.
4. Do not tie down front of boom.

Note: The user assumes all responsibility for choosing the proper method of transportation and tie-down devices, making sure the equipment used is capable of supporting the weight of the vehicle being transported and that all manufacturer's instructions and warnings, regulations and safety rules of their employer, the Department of Transportation and/or any other local, state or federal/provincial laws are followed.



WARNING

TELEHANDLER SLIDE HAZARD. Before loading telehandler for transport, make sure deck, ramps and telehandler wheels are free of mud, snow and ice. Failure to do so could cause telehandler to slide.

Section 4 - Operation

Lifting

- When lifting machine, it is very important that the lifting device and equipment is attached only to designated lifting points. If machine is not equipped with lifting lugs contact JLG Product Safety for information.
- Make adjustments to the lifting device and equipment to ensure the machine will be level when elevated. The machine must remain level at all times while being lifted.
- Ensure that the lifting device and equipment is adequately rated and suitable for the intended purpose. See Section 9 - Specifications for machine weight or weigh machine.
- Remove all loose items from machine prior to lifting.

Lift machine with smooth, even motion. Set machine down gently. Avoid quick or sudden motions that could cause shock loads to machine and/or lifting devices.

SECTION 5 - ATTACHMENTS AND HITCHES

5.1 APPROVED ATTACHMENTS

To determine if an attachment is approved for use on the specific telehandler you are using, perform the following prior to installation.

- The attachment type, weight, dimensions and load center must be equal to or less than the data shown on a load chart located in the operator cab.
- The model on the load chart must match the model telehandler being used.
- Hydraulically powered attachments must only be used on machines equipped with auxiliary hydraulics.
- Hydraulically powered attachments that require auxiliary electrics must only be used on machines equipped with auxiliary hydraulics and electrics.

If any of the above conditions are not met, do not use the attachment. The telehandler may not be equipped with the proper load chart or the attachment may not be approved for the model telehandler being used. Contact JLG or the local Caterpillar dealer for further information.

5.2 UNAPPROVED ATTACHMENTS

Do not use unapproved attachments for the following reasons:

- Range and capacity limitations for “will fit,” homemade, altered, or other non-approved attachments cannot be established.
- An overextended or overloaded telehandler can tip over with little or no warning and cause serious injury or death to the operator and/or those working nearby.
- The ability of a non-approved attachment to perform its intended function safely cannot be assured.



WARNING

Use only approved attachments. Attachments which have not been approved for use with your telehandler could cause machine damage or an accident.

Section 5 - Attachments and Hitches

5.3 JLG SUPPLIED ATTACHMENTS

Attachment	Part Number	Applicable Standard			Quick Coupler	
		CE	ANSI	AUS	STD	UQC
Carriage, 48 in (1220 mm)	331-6310		X			X
	330-4234		X		X	
Carriage, 50 in (1270 mm)	350-9099		X	X		X
	336-3523		X		X	
Carriage, 1200 mm	330-4242	X				X
	350-0501	X			X	
Side Shift Carriage, 48 in (1220 mm)	331-3252		X	X		X
Rotate/Side Tilt Carriage, 48 in (1220 mm)	330-4243		X		X	
	331-3251		X	X		X
Fork, Pallet 2x4x48 in (50x100x1220 mm)	323-5738		X	X	X	X
Fork, Lumber 1.5x6x60 in (38x150x1525 mm)	323-5737		X	X	X	X
Fork, Block 2x2x48 in (50x50x1220 mm)	301-9752		X	X	X	X
Fork, Pallet 45x100x1070 mm	252-1454	X			X	X
Fork, Pallet 50x100x1200 mm	309-9179	X			X	X
Fork, Pallet 50x100x1525 mm	252-1456	X			X	X
Fork, Pallet 50x120x1200 mm	323-5635	X			X	X
Bucket, Light Material 1.0 yd ³ (0,8 m ³)	330-4237		X		X	
	350-0505	X			X	
Bucket, Light Material 1.7 yd ³ (1,3 m ³)	330-4236		X		X	
	350-0508	X			X	
Bucket, Grapple 1.0 yd ³ (0,8 m ³)	330-4240		X		X	
	350-0509	X			X	
Fork Mounted Hook	321-0556		X		X	X

This Page Intentionally Left Blank

Section 5 - Attachments and Hitches

5.4 TELEHANDLER/ATTACHMENT/FORK CAPACITY

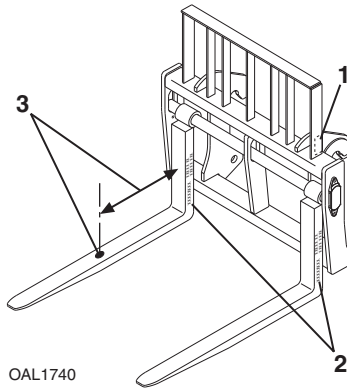

Prior to installing the attachment verify it is approved and the telehandler is equipped with the proper load chart. See “*Approved Attachments*” on page 5-1.

To determine the maximum capacity of the telehandler and attachment, use the **smallest** of the following capacities:

- Capacity stamped on the attachment identification plate (1).
- Fork capacities and load centers are stamped on the side of each fork (2) (if equipped). This rating specifies the maximum load capacity that the individual fork can safely carry at the maximum load center (3). Total attachment capacity is multiplied by the number of forks on the attachment (if equipped), up to the maximum capacity of the attachment.
- Maximum capacity as indicated on the proper load chart. See “*Approved Attachments*” on page 5-1.
- When the load rating of the telehandler differs from the capacity of the forks or attachment, the lower value becomes the overall load capacity.

Use the proper load chart to determine maximum capacity at various machine configurations. Lifting and placing a load may require use of more than one load chart based on machine configuration.

Other than block forks, all forks should be used in matched pairs, block forks used in matched sets.



WARNING

Never use an attachment without the appropriate JLG approved load chart installed on the telehandler.

5.5 USE OF THE LOAD CHART

To properly use the load chart (see page 5-6), the operator must first determine and/or have the following:

1. An approved attachment. See “*Approved Attachments*” on page 5-1.
2. The proper Load Chart(s).
3. Weight of the load being lifted.
4. Load placement information:
 - a. HEIGHT where the load is to be placed.
 - b. DISTANCE from the front tires of the telehandler to where the load is to be placed.
5. On the load chart, find the line for the height and follow it over to the distance.
6. The number in the load zone where the two cross is the maximum capacity for this lift. If the two cross at a division between zones, the smaller number must be used.

The number in the load zone must be equal to or greater than the weight of the load to be lifted. Determine the limits of the load zone on the load chart and keep within these limits.

Capacity Indicator Locations

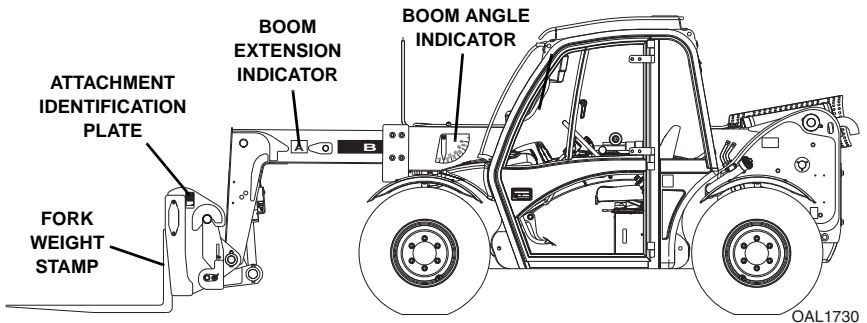

Section 5 - Attachments and Hitches

Sample Load Chart (ANSI & CE)

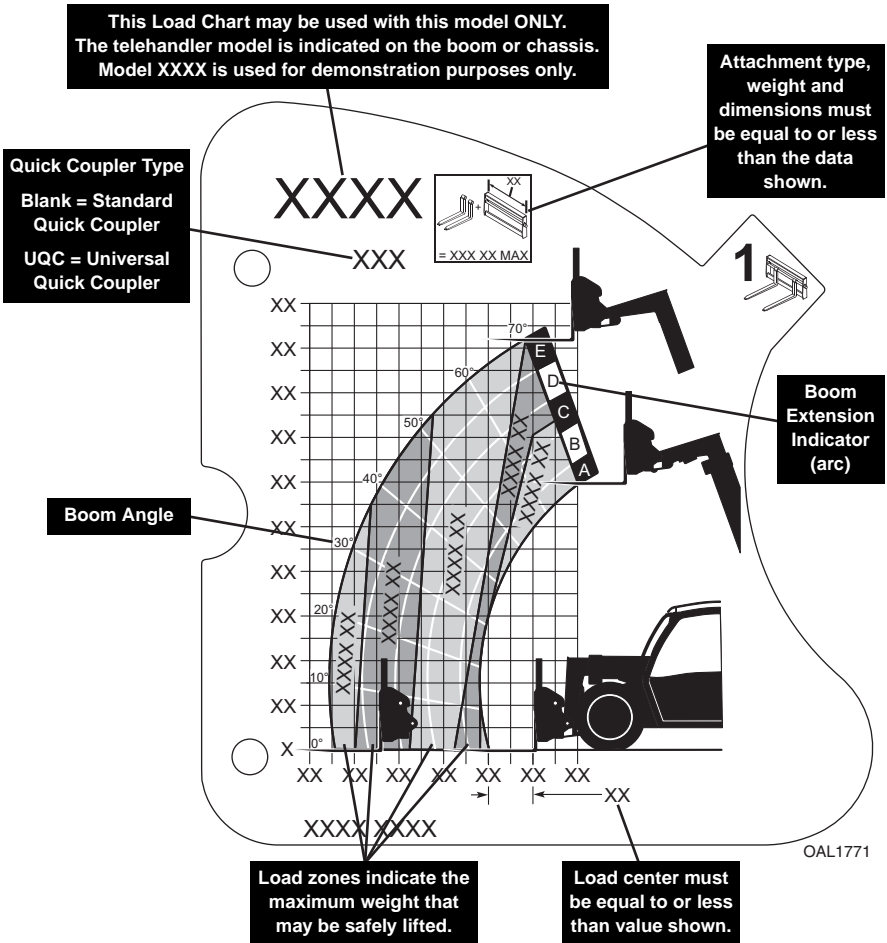

Note: This is a sample load chart **only!** **DO NOT** use this chart, use the one located in your operator cab.



WARNING

TIP OVER HAZARD. All loads shown on rated load chart are based on machine being on firm ground with frame level (see page 4-5); the forks being positioned evenly on carriage; the load being centered on forks; proper size tires being properly inflated; and the telehandler being in good operating condition.

Section 5 - Attachments and Hitches

Example

A contractor owns a model xxxxx telehandler with a fork carriage. He knows this attachment may be used with his model since:

- The attachment style, weight, dimensions and load center match the attachment data on the load chart.
- The load chart is clearly marked for model xxxxx and corresponds with machine configuration being used.

Below are examples with various conditions the contractor may encounter and whether or not the load may be lifted.

	Load Weight	Distance	Height	OK to Lift
1	2500 lb (1134 kg)	6 ft (1,8 m)	4 ft (1,2 m)	Yes
2	2000 lb (907 kg)	9.5 ft (2,9 m)	8 ft (2,4 m)	NO
3	3000 lb (1361 kg)	4 ft (1,2 m)	9 ft (2,7 m)	Yes
4	5250 lb (2381 kg)	2 ft (0,6 m)	16 ft (4,9 m)	NO

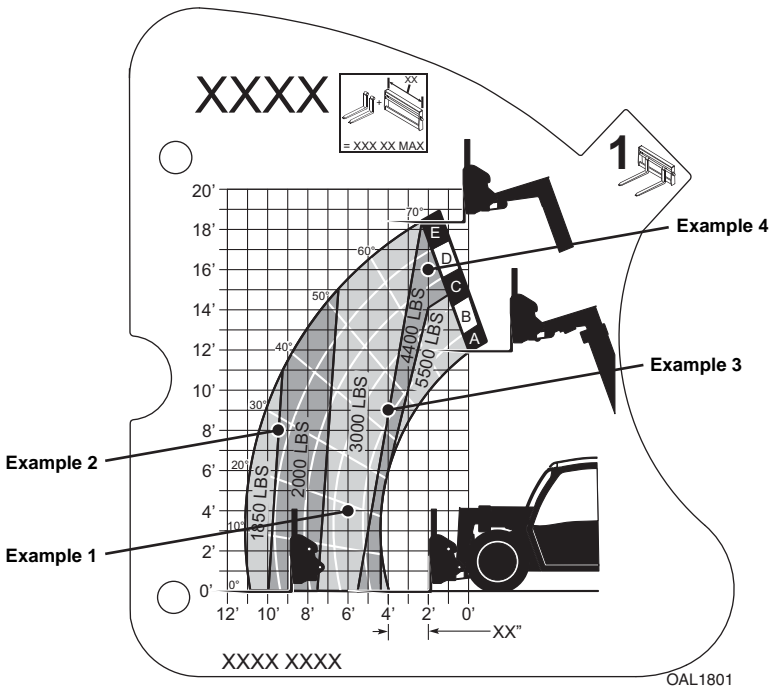

Note: This is a sample load chart **only!** **DO NOT** use this chart, use the one located in your operator cab.

5.6 ATTACHMENT INSTALLATION

Standard Quick Coupler

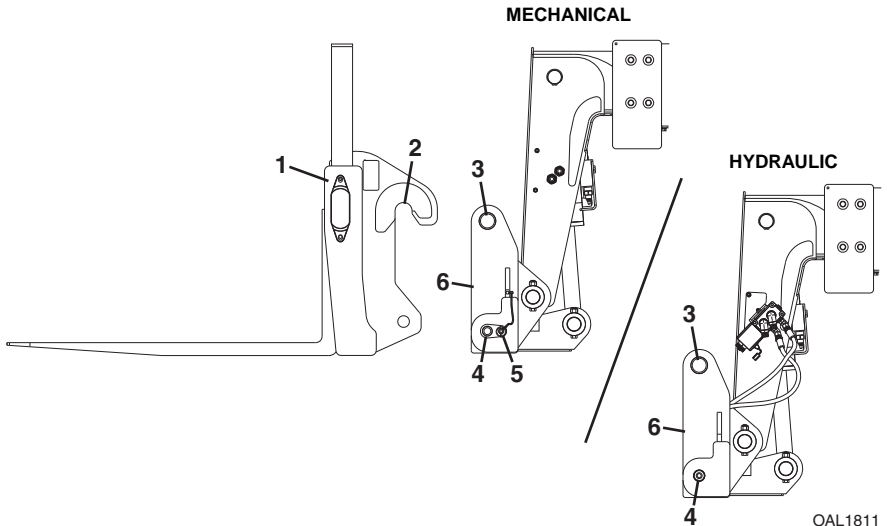

1. Attachment
2. Attachment Pin Recess
3. Attachment Pin
4. Lock Pin
5. Retainer Pin (mechanical coupler)
6. Quick Coupler (attachment tilt control in cab, see page 3-14 or 3-15)



WARNING

CRUSH HAZARD. Always be certain that carriage or attachment is properly positioned on boom and is secured by lock pin and retainer pin. Failure to ensure proper installation could permit carriage/attachment/load to disengage.

Section 5 - Attachments and Hitches

Mechanical Quick Coupler

This installation procedure is designed for one-person operation. Prior to exiting cab, perform “*Shut-Down Procedure*” on page 4-3.

1. Tilt quick coupler forward to provide clearance. Check to be sure lock pin and retainer pin are out.

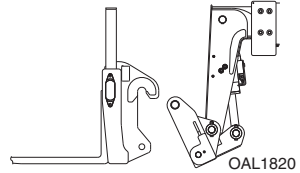

2. Align attachment pin with recess in attachment. Raise boom slightly to engage attachment pin in recess.

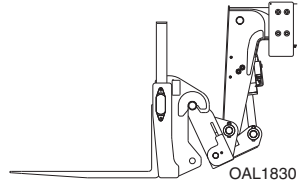

3. Tilt quick coupler back to engage attachment.

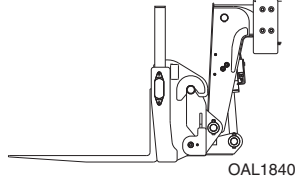

4. Insert lock pin and secure with retainer pin.

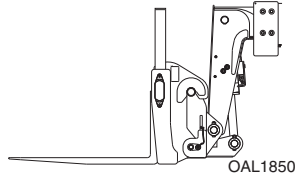

5. If attachment is equipped, connect auxiliary hydraulic hoses. See “*Hydraulic Operated Attachment*” on page 5-14.

Section 5 - Attachments and Hitches

Hydraulic Quick Coupler

This installation procedure is designed for one-person operation.

1. Tilt quick coupler forward to provide clearance.
Check to be sure lock pin is disengaged.

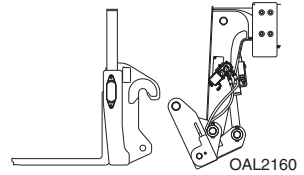

2. Align attachment pin with recess in attachment.
Raise boom slightly to engage attachment pin in recess.

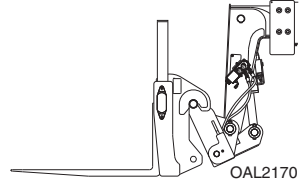

3. Tilt quick coupler back to engage attachment.

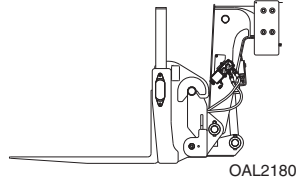

4. Press and hold switch (1) and button (2), at the same time move the joystick right to engage or left to disengage the quick coupler.

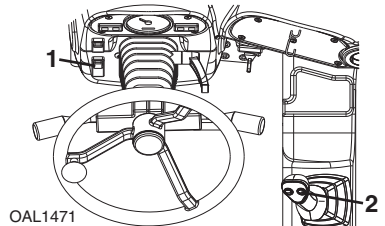

5. Raise boom to eye level and visually check that the quick coupler pin protrudes through the hole. If the pin does not protrude through the hole, place the attachment on the ground and return to step 2.

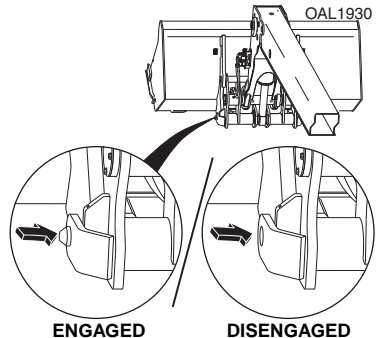

6. If attachment is equipped, connect auxiliary hydraulic hoses. See "Hydraulic Operated Attachment" on page 5-14.

Section 5 - Attachments and Hitches

Universal Quick Coupler (UQC)

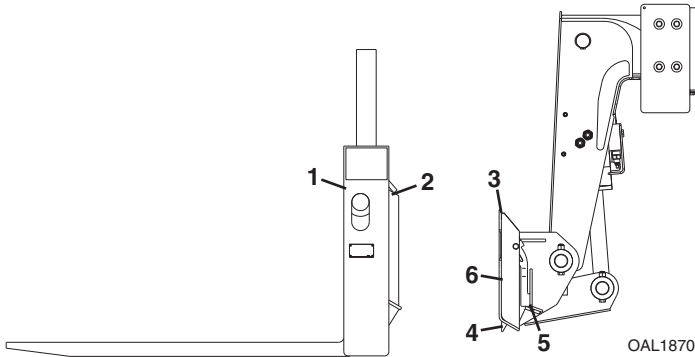

1. Attachment
2. Attachment Recess
3. Engaging Edge
4. Lock Pin
5. Lock Pin Handle
6. Universal Quick Coupler (attachment tilt control in cab, see page 3-14 or 3-15)



WARNING

CRUSH HAZARD. Always be certain that carriage or attachment is properly positioned on boom and is secured by lock pin. Failure to ensure proper installation could permit carriage/attachment/load to disengage.

Section 5 - Attachments and Hitches

This installation procedure is designed for one-person operation. Prior to exiting cab, perform “*Shut-Down Procedure*” on page 4-3.

1. Tilt quick coupler forward to provide clearance. Check to be sure lock pin handles and pins are pulled up.

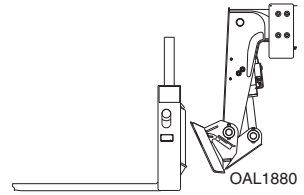

2. Align engaging edge with recess in attachment. Raise boom slightly to engage edge in recess.

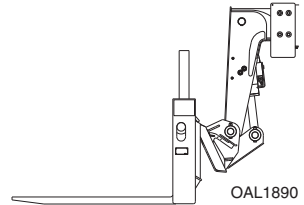

3. Tilt quick coupler back to engage attachment.

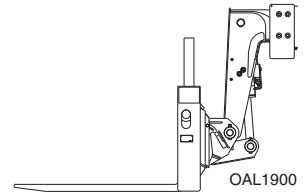

4. Lower lock pin handles to engage lock pins.

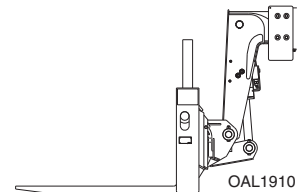

5. If attachment is equipped, connect auxiliary hydraulic hoses. See “*Hydraulic Operated Attachment*” on page 5-14.

Section 5 - Attachments and Hitches

5.7 HYDRAULIC OPERATED ATTACHMENT

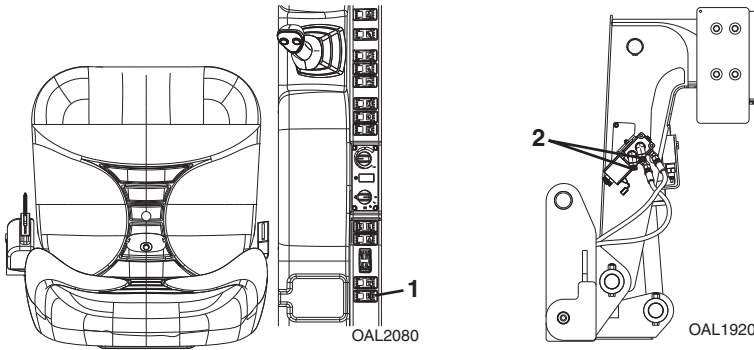

1. Install attachment (see page 5-9 or 5-12).
2. Press and hold auxiliary hydraulic pressure relief switch (1) for two seconds to relieve pressure at both auxiliary fittings (2).
3. Perform "Shut-Down Procedure" on page 4-3.
4. Connect attachment hoses to both auxiliary fittings.

5.8 ADJUSTING/MOVING FORKS

Carriages may have different locations where forks can be positioned. Two different methods can be used for repositioning, depending upon the carriage structure.

Note: Apply a light coating of appropriate lubricant to ease sliding of forks or fork bar.

To slide forks:

1. Ensure attachment is properly installed. See “Attachment Installation” on page 5-9 or “Universal Quick Coupler (UQC)” on page 5-12.
2. Elevate attachment to approximately 5 ft (1,5 m) and tilt carriage forward until fork heel is free from attachment.
3. Stand at the side of the carriage. To slide fork toward the center of the carriage, push the fork near the fork eye. To slide fork toward the edge of the carriage, pull the fork near the fork eye. To avoid pinching, do not place fingers or thumb between the fork and carriage structure.

If removing fork bar is necessary:

1. Rest forks on ground.
2. Remove fork bar.
3. Reposition forks.
4. Reinstall the fork bar and fork bar retaining mechanism(s).

Section 5 - Attachments and Hitches

5.9 ATTACHMENT OPERATION

- Capacities and range limits for the telehandler change depending on the attachment in use.
- Separate attachment instructions must be kept in manual holder in cab with this Operation & Maintenance Manual. An additional copy must be kept with the attachment if it is equipped with a manual holder.

Note: Operations described within this section reference the Lift joystick pattern. Refer to page 3-15 if using Loader joystick pattern.

NOTICE

EQUIPMENT DAMAGE. Some attachments may contact the front tires or machine structure when the boom is retracted and the attachment is rotated. Improper use of attachment may result in attachment or machine structural damage.

NOTICE

EQUIPMENT DAMAGE. Avoid contact with any structure or object when lifting a load. Maintain clearance around boom structure and load. Failure to maintain clearance may result in attachment or machine structural damage.

This Page Intentionally Left Blank

Section 5 - Attachments and Hitches

Carriage w/Forks

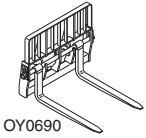

Use Carriage Attachment Load Chart

To determine maximum capacity, refer to "Telehandler/ Attachment/Fork Capacity" on page 5-4.

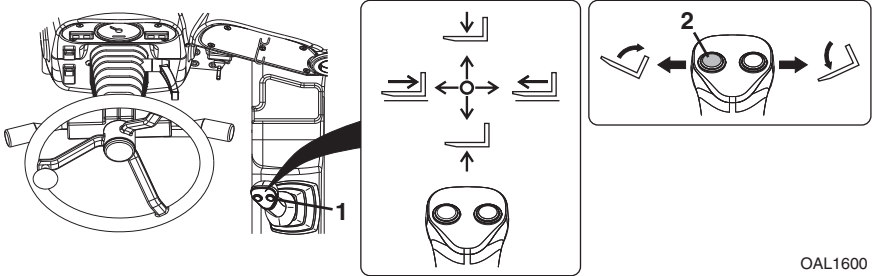

The joystick (1) controls lift/lower and the extend/retract movement of the boom.

The tilt button (2) enables fork tilt.

- While pressing and holding button move joystick left to tilt up.
- While pressing and holding button move joystick right to tilt down.

Installation Procedure:

- Refer to "Attachment Installation" on page 5-9.

Equipment Damage Precautions:

- Do not use forks as a lever to pry material. Excessive prying forces could damage forks or machine structure.
- Do not attempt to lift loads that are attached or connected to another object.

Fork Mounted Hook (ANSI & CE)

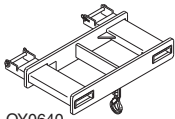

OY0640

Use Appropriate Carriage Load Chart

To determine maximum capacity, refer to “*Telehandler/ Attachment/Fork Capacity*” on page 5-4.

Suspend loads in accordance with requirements set forth in Section 1 - General Safety Practices.

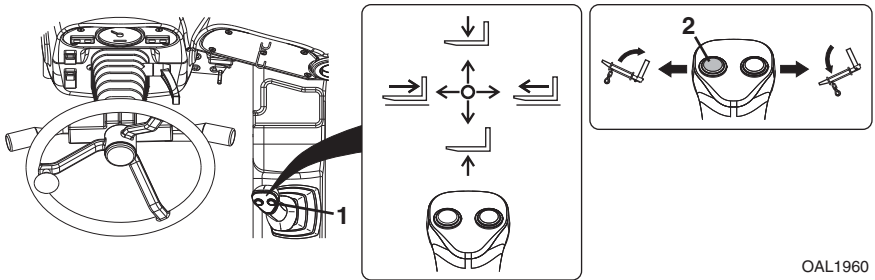

OAL1960

The joystick (1) controls lift/lower and the extend/retract movement of the boom.

The tilt button (2) enables fork mounted hook tilt.

- While pressing and holding button move joystick left to tilt up.
- While pressing and holding button move joystick right to tilt down.

Installation Procedure:

- Ensure carriage is properly installed. Refer to “*Attachment Installation*” on page 5-9.
- Secure the fork mounted hook to the forks by sliding the fork mounted hook onto the parent forks and install the retaining pin behind the vertical shank of the fork.

Operation:

- Pallet or lumber forks of an appropriate load rating must be used. Do not use with cubing or block forks.
- Weight of fork mounted hook and rigging must be included as part of total load being lifted.
- Do not use fork mounted hook with attachments capable of rotating (i.e. side tilt and swing carriages) without disabling the rotation features.

Section 5 - Attachments and Hitches

Rotate/Side Tilt Carriage

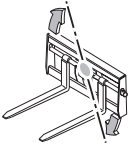

OAL1550

Use Rotate/Side Tilt Carriage Attachment Load Chart

To determine maximum capacity, refer to "Telehandler/ Attachment/Fork Capacity" on page 5-4.

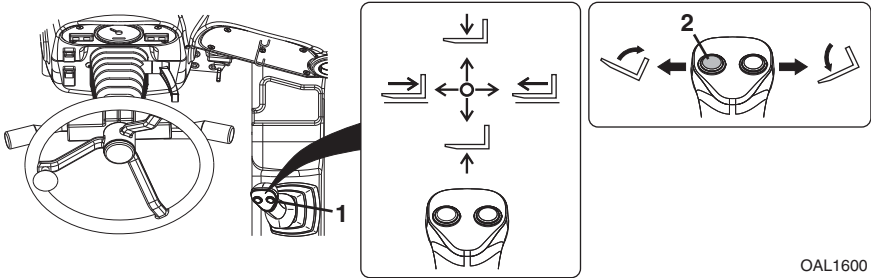

OAL1600

The joystick (1) controls lift/lower and the extend/retract movement of the boom.

The tilt button (2) enables fork tilt.

- While pressing and holding button move joystick left to tilt up.
- While pressing and holding button move joystick right to tilt down.

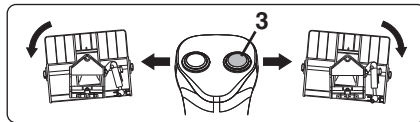

OAL1950

To Rotate:

The auxiliary hydraulic button (3) enables carriage rotation.

- While depressing button move joystick right to rotate right.
- While depressing button move joystick left to rotate left.

Installation Procedure:

- Refer to "Attachment Installation" on page 5-9.



WARNING

CRUSH HAZARD. Do not use rotation to push or pull objects or load. Failure to comply could cause object or load to fall.

Equipment Damage Precautions:

- Do not use forks as a lever to pry material. Excessive prying forces could damage forks or machine structure.
- Do not attempt to lift loads that are attached or connected to another object.

Section 5 - Attachments and Hitches

Side Shift Carriage

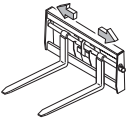

OAL1540

Use Side Shift Carriage Attachment Load Chart

To determine maximum capacity, refer to "Telehandler/Attachment/Fork Capacity" on page 5-4.

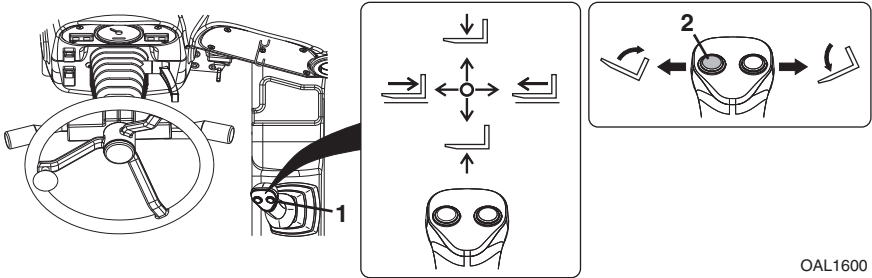

OAL1600

The joystick (1) controls lift/lower and the extend/retract movement of the boom.

The tilt button (2) enables fork tilt.

- While pressing and holding button move joystick left to tilt up.
- While pressing and holding button move joystick right to tilt down.

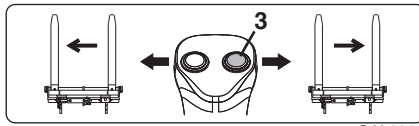

OAL2210

To Side Shift:

The auxiliary hydraulic button (3) enables carriage side shift.

- While depressing button move joystick right to side shift right.
- While depressing button move joystick left to side shift left.

Installation Procedure:

- Refer to "Attachment Installation" on page 5-9.



WARNING

CRUSH HAZARD. Do not use side shift to push or pull objects or load. Failure to comply could cause object or load to fall.

Equipment Damage Precautions:

- Do not use forks as a lever to pry material. Excessive prying forces could damage forks or machine structure.
- Do not attempt to lift loads that are attached or connected to another object.

Section 5 - Attachments and Hitches

Bucket

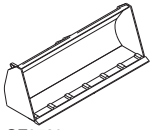

OZ0730

Use Appropriate Bucket Load Chart

To determine maximum capacity, refer to "Telehandler/ Attachment/Fork Capacity" on page 5-4.

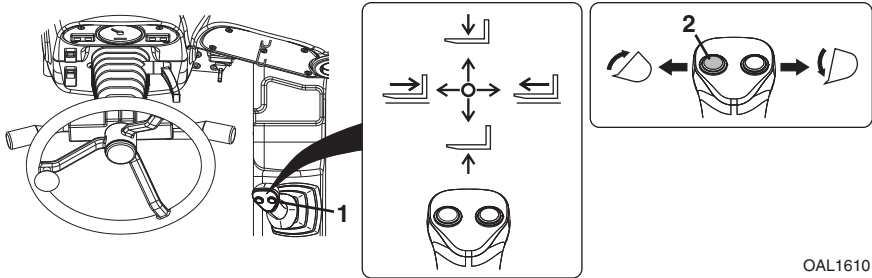

OAL1610

The joystick (1) controls lift/lower and the extend/retract movement of the boom.

The tilt button (2) enables bucket tilt.

- While pressing and holding button move joystick left to tilt up.
- While pressing and holding button move joystick right to tilt down.

Installation Procedure:

- Refer to "Attachment Installation" on page 5-9.

Operation:

- Raise or lower boom to appropriate height for loading material from stockpile.
- Align telehandler with face of stockpile and drive slowly and smoothly into pile to load bucket.
- Tilt bucket up far enough to retain load and back away from pile.
- Travel in accordance with requirements set forth in Section 1 - General Safety Practices.
- Tilt bucket down to dump load.

Equipment Damage Precautions

- Except for lifting or dumping a load, the boom must be fully retracted for all bucket operations.
- Do not corner-load bucket. Distribute material evenly within the bucket. Bucket load charts are for evenly distributed loads only.
- Do not use bucket as a lever to pry material. Excessive prying forces could damage bucket or machine structure.
- Do not attempt to load material which is hard or frozen. This could cause severe damage to quick coupler or machine structure.
- Do not use bucket for "back dragging." This could cause severe damage to quick coupler.

Section 5 - Attachments and Hitches

Grapple Bucket

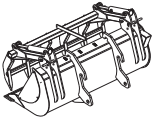

OZ1450

Use Grapple Bucket Load Chart

To determine maximum capacity, refer to "Telehandler/Attachment/Fork Capacity" on page 5-4.

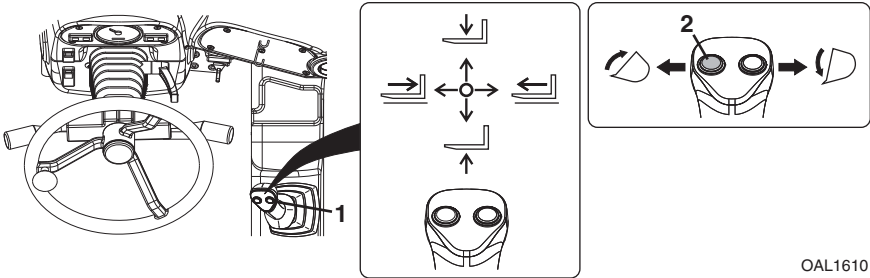

OAL1610

The joystick (1) controls lift/lower and the extend/retract movement of the boom.

The tilt button (2) enables bucket tilt.

- While pressing and holding button move joystick left to tilt up.
- While pressing and holding button move joystick right to tilt down.

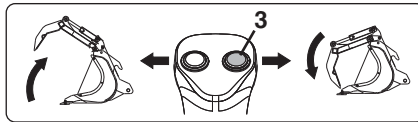

OAL1970

To open/close grapple:

The auxiliary hydraulic button (3) enables open/close movement of the grapple.

- While depressing button move joystick right to close grapple.
- While depressing button move joystick left to open grapple.

Installation Procedure:

- Refer to "Attachment Installation" on page 5-9.

Section 5 - Attachments and Hitches

Operation:

- Raise or lower boom to appropriate height and open grapple for loading material from stockpile.
- Align telehandler with face of stockpile and drive slowly and smoothly into pile to load bucket.
- Tilt bucket up far enough to retain load, close grapple and back away from pile.
- Travel in accordance with requirements set forth in Section 1 - General Safety Practices.
- Open grapple and tilt bucket down to dump load.

Equipment Damage Precautions

- Except for lifting or dumping a load, the boom must be fully retracted for all bucket operations.
- Do not corner-load bucket. Distribute material evenly within the bucket. Bucket load charts are for evenly distributed loads only.
- Do not use bucket as a lever to pry material. Excessive prying forces could damage bucket or machine structure.
- Do not attempt to load material which is hard or frozen. This could cause severe damage to quick coupler or machine structure.
- Do not use bucket for "back dragging." This could cause severe damage to quick coupler.

Section 5 - Attachments and Hitches

Material Handling Arm (ANSI & CE)

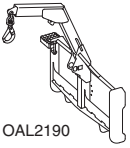

OAL2190

Use Material Handling Arm Load Chart

To determine maximum capacity, refer to “Telehandler/ Attachment/Fork Capacity” on page 5-4.

Suspend loads in accordance with requirements set forth in Section 1 - General Safety Practices.

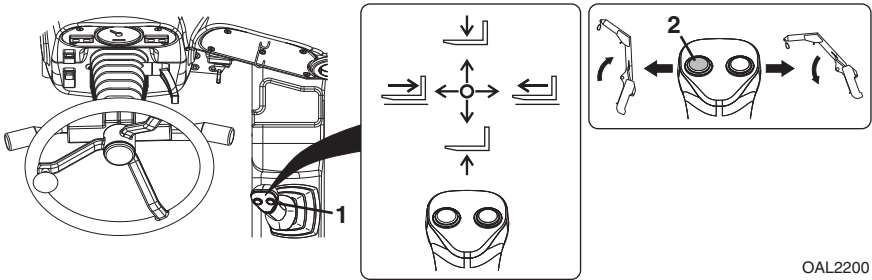

OAL2200

The joystick (1) controls lift/lower and the extend/retract movement of the boom.

The tilt button (2) enables material handling arm tilt.

- While pressing and holding button move joystick left to tilt up.
- While pressing and holding button move joystick right to tilt down.

Installation Procedure:

- Refer to “Attachment Installation” on page 5-9.

Operation:

- Weight of rigging must be included as part of total load being lifted.

5.10 HITCHES

This machine is not approved for on-highway towing.

Maximum towing capacity shall be the smallest of the telehandler and hitch capacities. Refer to local governmental regulations for additional towing requirements and/or restrictions.

Note: *Speed and/or load may need reduced if traveling on ground which is not level.*

If not previously installed, secure hitch to machine with hardware supplied with installation.

Pin Hitch

Maximum combined weight of trailer and load 5500 lb (2500 kg)

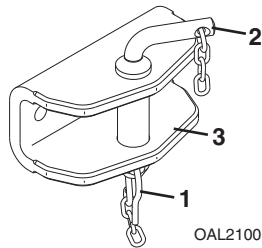

Connecting trailer for towing:

1. Remove safety pin (1) and pull pin (2) from hitch (3).
2. Align machine and tow eye of trailer.
3. Place pin through hitch and tow eye. Secure pin with safety pin.

Section 5 - Attachments and Hitches

Adjustable Pin Hitch

Maximum combined weight of trailer and load5500 lb (2500 kg)

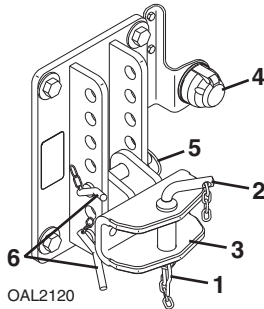

Connecting trailer for towing:

1. Remove safety pin (1) and pull pin (2) from hitch (3).
2. Align machine and tow eye of trailer.
3. Place pin through hitch and tow eye. Secure pin with safety pin.
4. If equipped, connect trailer harness to trailer plug (4).

Adjusting Hitch Height:

1. Remove safety pins (5).
2. While supporting hitch, remove pins (6).
3. Move hitch to desired height.
4. Replace pins and secure with safety pins.

Adjustable Auto Hitch

Maximum combined weight of trailer and load 5500 lb (2500 kg)

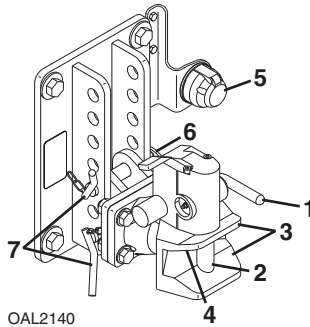

Connecting trailer for towing:

1. Rotate lever (1) until pin (2) fully retracts.
2. Align hitch mouth (3) and tow eye of trailer.
3. Reverse machine toward trailer.
4. After the tow eye contacts trigger (4), the pin and lever will be released.
5. If equipped, connect trailer harness to trailer plug (5).

Adjusting Hitch Height:

1. Remove safety pins (6).
2. While supporting hitch, remove pins (7).
3. Move hitch to desired height.
4. Replace pins and secure with safety pins.

This Page Intentionally Left Blank

SECTION 6 - EMERGENCY PROCEDURES

6.1 TOWING A DISABLED PRODUCT

The following information assumes the telehandler cannot be moved under its own power.

- Before moving the telehandler, read all of the following information to understand options available. Then select the appropriate method.
- Machine mounted retrieval devices provide suitable means to attach a tow rope, chain or tow bar only in the event the telehandler becomes stuck or disabled. Retrieval devices are not intended for trailer towing applications.
- The steering system permits manual steering if engine or power assist feature fails; however, **steering will be slow and will require much greater force.**
- **DO NOT** attempt to tow a telehandler that is loaded or the boom/attachment is raised above 4 ft (1,2 m).

Moving Short Distances

- If it is only necessary to move telehandler a short distance, less than 100 ft (30 m), it is permissible to use a vehicle of sufficient capacity to tow the unit with no previous preparation. Drive wheels will not roll.

Moving Longer Distances

- If the telehandler must be moved longer distances, it must be loaded onto a trailer of sufficient capacity.

Contact the local Caterpillar dealer for specific instructions if neither of these methods are applicable.

Section 6 - Emergency Procedures

6.2 EMERGENCY LOWERING OF BOOM

In the event of total loss of engine power or hydraulic pump failure with an elevated load, the situation must be properly evaluated and dealt with on an individual basis.

Contact the local Caterpillar dealer for specific instructions.

Secure the telehandler using the following procedures:

1. Clear the area around telehandler of all personnel.
2. Engage the parking brake. Place the transmission control lever in "NEUTRAL".
3. Block all four wheels.
4. Section off a large area under the boom with string or tape to restrict any personnel from entering this area.

6.3 EMERGENCY EXIT FROM ENCLOSED CAB

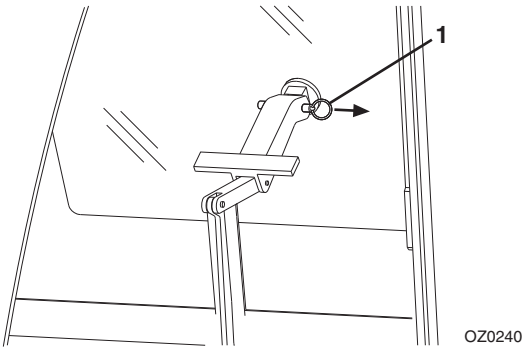

In an emergency the rear window can be used to exit the telehandler.

- Remove the latch pin (1). The window is then free to swing open.

SECTION 7 - LUBRICATION AND MAINTENANCE

7.1 INTRODUCTION

Service the product in accordance with the maintenance schedule on the following pages.

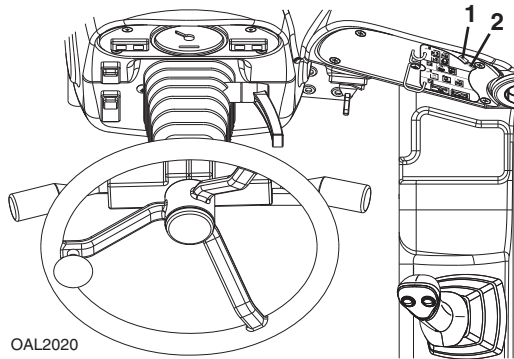

The Lubrication (1) and Maintenance (2) Charts contain instructions that must be followed to keep this product in good operating condition. The Operation & Maintenance Manual and Service Manual contain more detailed service information with specific instructions.

Clothing and Safety Gear

- Wear all the protective clothing and personal safety devices issued to you or called for by job conditions.
- **DO NOT** wear loose clothing or jewelry that can get caught on controls or moving parts.

Section 7 - Lubrication and Maintenance

7.2 GENERAL MAINTENANCE INSTRUCTIONS

Prior to performing any service or maintenance on the telehandler, follow the shut-down procedure on page 4-3 unless otherwise instructed. Ensure telehandler is level, for proper fluid readings.

- Clean lubrication fittings before lubricating.
- After greasing telehandler, cycle all functions several times to distribute lubricants. Perform this maintenance procedure without attachment installed.
- Apply a light coating of engine oil to all linkage pivot points.
- Intervals shown are for normal usage and conditions. Adjust intervals for abnormal usage and conditions.
- Drain engine and gear cases after operating when oil is hot.
- Check all lubricant levels when lubricant is cool. For ease of filling hydraulic reservoir, use a funnel with a hose or flexible tube for best results.



WARNING

CUT/CRUSH/BURN HAZARD. Do not perform service or maintenance on the machine with the engine running.

7.3 SERVICE AND MAINTENANCE SCHEDULE

10 & 1st 50 & 50 Hour Maintenance Schedule



EVERY

10 



Check Fuel Level



Check Engine Oil Level

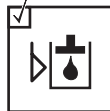

Check Hydraulic Oil Level



Check Tire Condition & Pressure

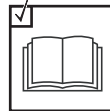

Additional Checks - Section 8

1st

50 



Check Wheel Lug Nut Torque

EVERY

50 



Drain Fuel/Water Separator



Check Engine Coolant Level



Check Air Filter

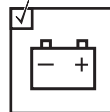

Check Battery



Check Brake Fluid Level

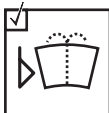

Check Washer Fluid Level (if equipped)

Section 7 - Lubrication and Maintenance

1st 250, 250 & 500 Hour Maintenance Schedule



1st

250 

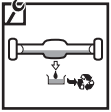

Change Axle Differential Oil

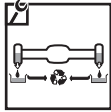

Change Wheel End Oil

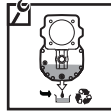

Change Front Axle Drop Box Oil

EVERY

250 



Check Boom Wear Pads



Lubrication Schedule

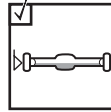

Check Axle Differential Oil Level

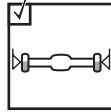

Check Wheel End Oil Levels

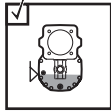

Check Front Axle Drop Box Oil Level



Check Fan Belt

EVERY

500 



Change Fuel Filter



Change Engine Oil and Filter



Change Air Filter Elements



Check Wheel Lug Nut Torque



Check LSI Calibration

OAL2003

Section 7 - Lubrication and Maintenance

1000 Hour Maintenance Schedule



EVERY
1000 

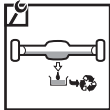

Change Axle
Differential Oil

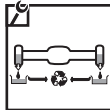

Change Wheel
End Oil

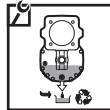

Change Front
Axle Drop
Box Oil

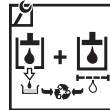

Change
Hydraulic
Fluid & Filters



Check
Hydraulic Tank
Cap



Change
Transmission
Filter



Change
Engine Coolant

OAL2012

This Page Intentionally Left Blank

Section 7 - Lubrication and Maintenance

7.5 OPERATOR MAINTENANCE INSTRUCTIONS

Fuel System

A. Fuel Level Check

10 
OW0970

OW0990

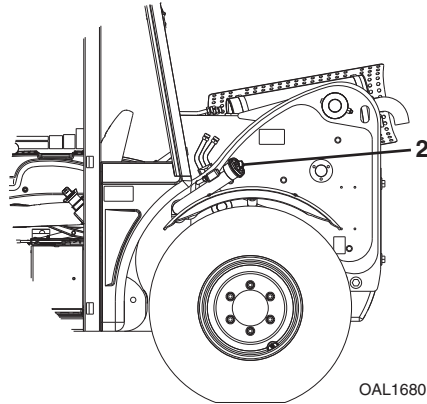
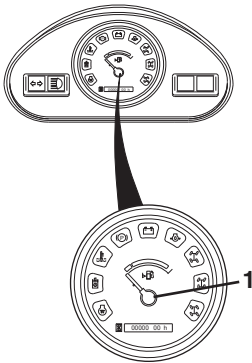

OAL1680

1. Check fuel gauge (1) located on instrument panel in cab.
2. If fuel is low, proceed to fuel source and perform “Shut-Down Procedure” on page 4-3.
3. Turn fuel tank cap (2) and remove from filler neck.
4. Add diesel fuel as needed.
5. Replace fuel tank cap.

Note: Replenish diesel fuel at end of each work shift to minimize condensation.

NOTICE

EQUIPMENT DAMAGE. Do not allow machine to run out of fuel during operation. See Engine Operation & Maintenance Manual for details prior to servicing.

B. Drain Fuel/Water Separator

50 
OW0980

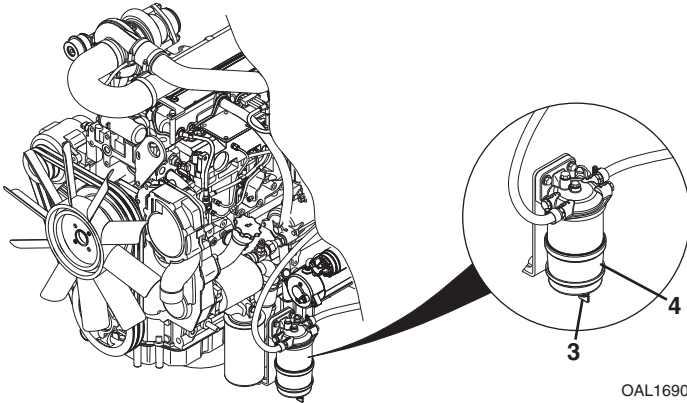

1. Perform "Shut-Down Procedure" on page 4-3.
2. Open the engine cover.
3. Loosen drain cock (3) on underside of fuel filter (4) and allow all water to drain into a glass until clear fuel is visible. Tighten drain cock.
4. Close and secure the engine cover.

Section 7 - Lubrication and Maintenance

Engine Oil

A. Engine Oil Level Check

10 
OW0970

OW1020

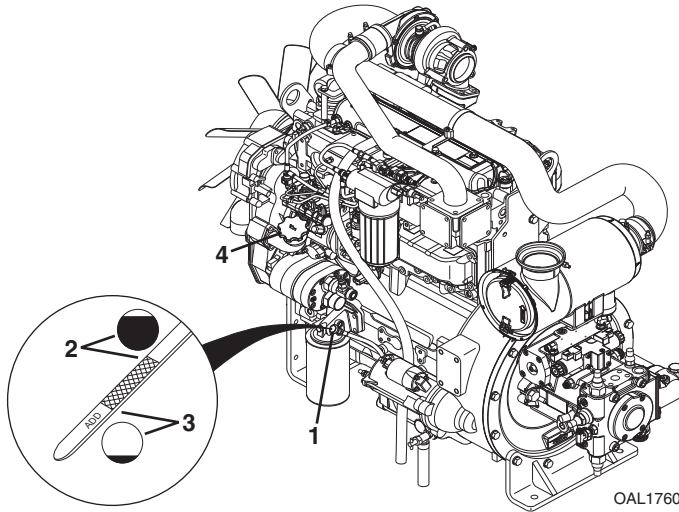

1. Perform "Shut-Down Procedure" on page 4-3.
2. Open the engine cover.
3. Remove dipstick (1) and check oil mark. The oil should be between the full (2) and add (3) marks within the crosshatched area of the dipstick.
4. Replace dipstick.
5. If oil is low, remove oil fill cap (4) and add motor oil to bring oil up to the full mark in the crosshatch area.
6. Replace oil fill cap.
7. Close and secure the engine cover.

Hydraulic Oil

A. Hydraulic Oil Level Check

10 
OW0970

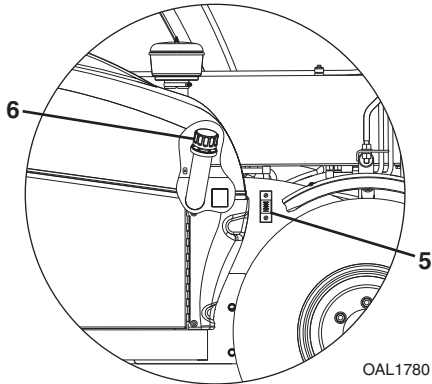

1. Perform “*Shut-Down Procedure*” on page 4-3.
2. Check level of hydraulic oil at the sight gauge (5) on the frame. The oil level should be visible in the gauge window.
3. If hydraulic oil is low, open the engine cover and remove oil fill cap (6) from filler neck. Add hydraulic fluid to bring oil up to the upper mark on the sight gauge.
4. Replace hydraulic oil fill cap.
5. Close and secure the engine cover.

Section 7 - Lubrication and Maintenance

Tires

A. Tire Air Pressure Check



1. Perform “Shut-Down Procedure” on page 4-3.
2. Remove valve stem cap.
3. Check tire pressure.
4. Add air if required.

12.00 x 16.5, Bias-Ply - 12 Ply	80 psi (5,5 bar)
14.00 x 17.5, Bias Ply - 10 Ply	70 psi (4,8 bar)
5. Replace valve stem cap.

B. Tire Damage

For pneumatic tires, when any cut, rip or tear is discovered that exposes sidewall or tread area cords in the tire, measures be taken to remove the product from service immediately. Arrangements must be made for replacement of the tire or tire assembly.

For polyurethane foam filled tires, when any of the following are discovered, measures must be taken to remove the product from service immediately. Arrangements must be made for replacement of the tire or tire assembly.

- a smooth even cut through the cord piles which exceeds 3 in (7,5 cm) in total length.
- any tears or rips (ragged edges) in the cord plies which exceeds 1 in (2,5 cm) in any direction
- any punctures which exceed 1 in (2,5 cm) in diameter.

If a tire is damaged but within the above noted criteria, the tire must be inspected daily to ensure the damage has not propagated beyond the allowable criteria.

C. Tire and Wheel Replacement

It is recommended that a replacement tire to be the same size, ply and brand as originally installed. Refer to the appropriate parts manual for ordering information. If not using an approved replacement tire, the replacement tires must have the following characteristics:

- Equal or greater ply/load rating and size of original.
- Tire tread contact width equal or greater than original.
- Wheel diameter, width and offset dimensions equal to the original.

Section 7 - Lubrication and Maintenance

- Approved for the application by the tire manufacturer (including inflation pressure and maximum tire load).

Unless specifically approved by JLG, do not replace a foam filled or ballast filled tire assembly with a pneumatic tire. Due to size variations between tire brands, when selecting and installing a replacement tire ensure both tires on the axle are the same.

The rims installed have been designed for stability requirements which consist of track width, tire pressure and load capacity. Size changes such as rim width, center piece location, larger or smaller diameter, etc., without written factory recommendations, may result in unsafe condition regarding stability.

E. Wheel Installation

Torque lug nuts before first use and after each wheel removal.

Note: If machine is equipped with directional tire assemblies, the wheel and tire assemblies must be installed with the directional tread pattern "arrows" facing in the direction of forward travel.

1. Start all nuts by hand to prevent cross threading. DO NOT use a lubricant on threads or nuts.
2. Tighten lug nuts in an alternating pattern as indicated in figure. Torque to 220 lb-ft (300 Nm).

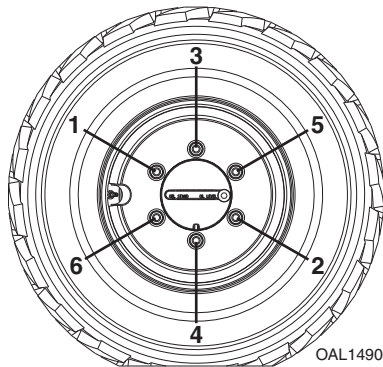

WARNING

TIP OVER HAZARD. Lug nuts must be installed and maintained at the proper torque to prevent loose wheels, broken studs and possible separation of wheel from the axle.

Section 7 - Lubrication and Maintenance

Air Intake System

A. Air Filter Check

50 
OW0980

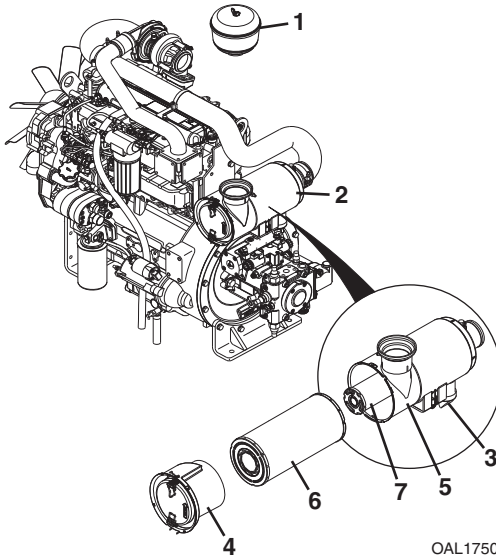

1. Perform "Shut-Down Procedure" on page 4-3.
2. Locate precleaner bowl (1) on engine cover, remove cover from precleaner canister.
3. Remove dust from precleaner bowl.
4. Replace precleaner bowl and secure cover.
5. Open the engine cover.
6. Locate air cleaner (2) and remove dust from vacuator valve (3) by squeezing bottom of valve to allow loose particles to fall out.
7. Close and secure engine cover.

B. Element Change

1. Remove air cleaner cover (4), remove from air cleaner canister (5).
2. Remove outer primary element (6) and inspect for damage. Damaged elements should not be reused.

Note: Care must be taken to not damage element during removal and replacement.

3. Thoroughly clean the interior of the air cleaner canister and vacuator valve.
4. Replace inner safety element (7) after every third primary element change. If replacing the inner safety element at this time, carefully slide the element out and replace with new element.
5. Slide the new primary element over the inner element making sure the sealing edge is flush with the base of the air cleaner.
6. Replace air cleaner cover.

Note: An inner safety element should never be washed or reused. Always install a new element.

Section 7 - Lubrication and Maintenance

Engine Cooling System

A. Engine Coolant Level Check

50 
OW0980

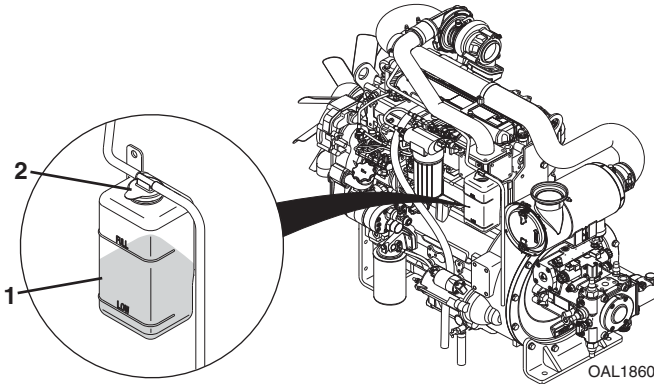

1. Perform “*Shut-Down Procedure*” on page 4-3.
2. Open the engine cover.
3. Check coolant level in overflow bottle (1). When coolant is hot, bottle should be 1/2 to 3/4 full. When coolant is cool, bottle should be 1/4 to 1/2 full.
4. If coolant is low, remove overflow bottle cap (2) and add coolant (50/50 mixture of ethylene glycol and water) as required.
5. Replace overflow bottle cap.
6. Close and secure the engine cover.

Note: When filling the engine with coolant, the maximum fill rate is 4 gallon per minute (15 liters per minute).

Battery

A. Battery Check

50 
OW0980

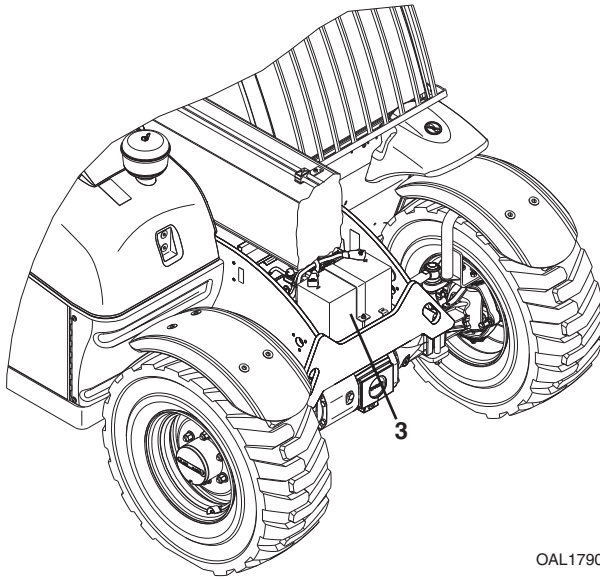
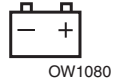

OAL1790

1. Perform “*Shut-Down Procedure*” on page 4-3.
2. Remove the battery cover.
3. Wearing eye protection, visually inspect the battery (3). Check terminals for corrosion. Replace battery if it has a cracked, melted or damaged case.
4. Replace and secure the battery cover.

Section 7 - Lubrication and Maintenance

Brake System

A. Brake Fluid Level Check

50 
OW0980

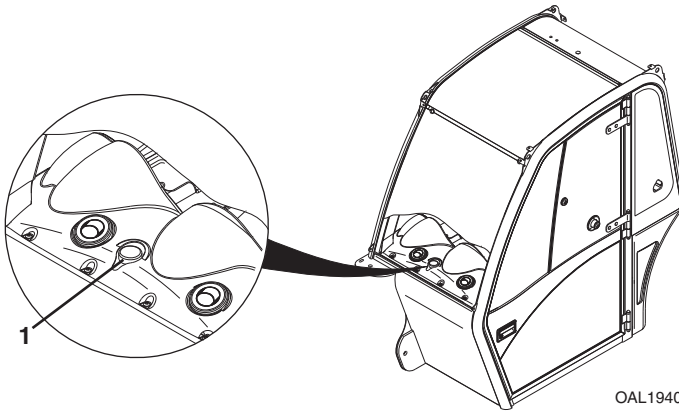

1. Perform “*Shut-Down Procedure*” on page 4-3.
2. The brake fluid level should be visible in the reservoir (1).
3. If brake fluid level is low, add hydraulic fluid as needed.

Note: All other work on the brake system must be performed by qualified personnel.

Windshield Washer System (if equipped)

A. Windshield Washer Fluid Level Check

50 
OW0980

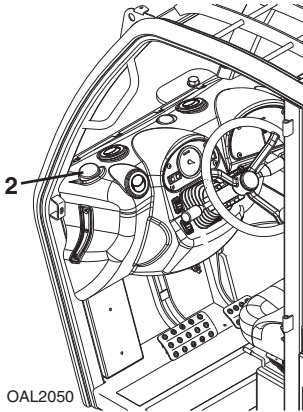

1. Perform "Shut-Down Procedure" on page 4-3.
2. The windshield washer fluid should be visible in the reservoir (2).
3. If washer fluid level is low, add fluid as needed.

This Page Intentionally Left Blank

SECTION 8 - ADDITIONAL CHECKS

8.1 GENERAL

If any of the following test results cannot be achieved, the system is not functioning properly and the machine must be removed from service and repaired before continued operation.

8.2 LOAD STABILITY INDICATOR SYSTEM (CE & AUS)

A. Load Stability Indicator System Test

10 
OW0970



The Load Stability Indicator (LSI) is intended to continuously monitor the forward stability of the telehandler. To check this feature, perform the following:

Before S/N TBS00627

1. Fully retract and level boom, with no load. Do not raise the boom during this test.
2. Ensure machine is level.
3. Press the test button on the LSI display. This will cause all LEDs to flash on and an audible warning to sound. This indicates that the system is functioning properly.

S/N TBS00627 & After

1. Fully retract and level boom, with no load. Do not raise the boom during this test.
2. Ensure machine is level.
3. Press the system check button on the LSI display. This will cause all LEDs to flash on and an audible warning to sound. This indicates that the system is functioning properly.

This Page Intentionally Left Blank

SECTION 9 - SPECIFICATIONS

9.1 PRODUCT SPECIFICATIONS

Fluids

Compartment or System	Type and Classification	Viscosities	Ambient Temperature Range			
			°F		°C	
			Min	Max	Min	Max
Engine Crankcase	Cat DEO Multigrade Cat DEO SYN Cat Arctic DEO SYN Cat ECF-1 API CG-4 Multigrade	SAE 0W-20	-40	50	-40	10
		SAE 0W-30	-40	86	-40	30
		SAE 0W-40	-40	104	-40	40
		SAE 5W-30	-22	86	-30	30
		SAE 5W-40	-22	122	-30	50
		SAE 10W-30	0	104	-18	40
		SAE 10W-40	0	122	-18	50
		SAE 15W-40	15	122	-9.5	50
Hydraulic System, Brake Reservoir, Axle Differentials and Wheel Ends	Cat TDTO Cat TDTO-TMS Cat Arctic TDTO SYN commercial TO-4	SAE 0W-20	-40	104	-40	40
		SAE 0W-30	-40	104	-40	40
		SAE 5W-30	-22	104	-30	40
		SAE 5W-40	-22	104	-30	40
		SAE 10W	-4	104	-20	40
		SAE 30	50	122	10	50
		SAE 10W-30	-4	104	-20	40
		SAE 15W-40	5	122	-15	50
		Cat TDTO-TMS	-4	122	-20	50
Boom Wear Pad Grease	Cat Advanced 3Moly	NLGI Grade 2	-4	104	-20	40
Cylinder and Axle Grease	Cat Multipurpose	NLGI Grade 2	-22	104	-30	40
Engine Coolant	Cat DEAC	50/50 Mix - Water and Glycol				
Fuel	#2 Diesel	Low Sulfur				
Air Conditioning	Refrigerant R-134a	Tetrafluoroethane				

Section 9 - Specifications

Capacities

Engine Crankcase Oil

Capacity with Filter Change..... 9.6 qt (9,1 L)

Fuel Tank

Capacity.....24 gal (91 L)

Cooling System

System Capacity..... 14.6 qt (13,8 L)

Overflow Bottle Capacity 0.6 qt (0,6 L)

Hydraulic System

System Capacity.....23.5 gal (90 L)

Reservoir Capacity to Full Mark 16 gal (61 L)

Auxiliary Hydraulic Circuit Max Flow20 gpm (75,7 lpm)

Brake System

System Capacity..... 0.7 qt (0,7 L)

Axles

Differential Housing Capacity 3.6 qt (3,4 L)

Wheel End Capacity10 oz (0,3 L)

Front Axle Drop Box21 oz (0,6 L)

Air Conditioning System (if equipped)

System Capacity.....2.5 lb (1134 g)

Tires

12.00 x 16.5, Bias-Ply - 12 Ply

Pneumatic80 psi (5,5 bar)

Foam Approx 220 lb (100 kg)

14.00 x 17.5, Bias - 10 Ply

Pneumatic70 psi (4,8 bar)

Foam Approx 220 lb (100 kg)

Wheel Lug Nut

Torque..... 220 lb-ft (300 Nm)

Performance

Maximum Lift Capacity

ANSI	5500 lb (2494 kg)
CE	2500 kg (5511 lb)
AUS	
Before S/N TBS00627	2500 kg (5511 lb)
S/N TBS00627 & After.....	2400 kg (5291 lb)

Maximum Lift Height..... 18.2 ft (5,5 m)

Capacity at Maximum Height

ANSI	
Standard Quick Coupler	4400 lb (1995 kg)
Universal Quick Coupler	
Before S/N TBS00629	4400 lb (1995 kg)
S/N TBS00629 & After	3000 lb (1360 kg)
CE	
Standard Quick Coupler	2000 kg (4409 lb)
Universal Quick Coupler	1360 kg (2998 lb)
AUS	
Before S/N TBS00627	2500 kg (5512 lb)
S/N TBS00627 & After.....	2400 kg (5291 lb)

Maximum Forward Reach 11 ft (3,4 m)

Capacity at Maximum Forward Reach

ANSI	
Standard Quick Coupler	1850 lb (839 kg)
Universal Quick Coupler	
Before S/N TBS00629	1800 lb (816 kg)
S/N TBS00629 & After	1700 lb (771 kg)
CE	
Standard Quick Coupler	800 kg (1764 lb)
Universal Quick Coupler	
Before S/N TBS00627	860 kg (1896 lb)
S/N TBS00627 & After	780 kg (1720 lb)
AUS	
Before S/N TBS00627	940 kg (2072 lb)
S/N TBS00627 & After.....	750 kg (1653 lb)

Reach at Maximum Height.....2 ft (0,6 m)

Maximum Travel Speed 18 mph (29 kph)

Section 9 - Specifications

Towing Capacity	
Off-Highway	5500 lb (2500 kg)
On-Highway	0 lb (0 kg)
Maximum Travel Grade (boom in travel position)	
Gradeability	45%
Side Slope	8.75%

Dimensions

Overall Height	75.6 in (1920 mm)
Overall Width	71.5 in (1816 mm)
Track Width	58.5 in (1486 mm)
Wheelbase	90.0 in (2286 mm)
Length at Front Wheels	129.9 in (3299 mm)
Overall Length (no attachment)	144.2 in (3663 mm)
Ground Clearance	10.8 in (274 mm)
Outside Turning Radius	126.0 in (3200 mm)
Turning Radius at Forks	169.0 in (4293 mm)
Maximum Gross Vehicle Weight (no attachment)	13 340 lb (6050 kg)
Maximum Front Axle Weight (no attachment) (boom level and fully retracted)	6696 lb (3037 kg)
Maximum Rear Axle Weight (no attachment) (boom level and fully retracted)	6644 lb (3013 kg)
Maximum Ground Bearing Pressure	
12.00 x 16.5	
Air Filled	148 lb/in ² (10,4 kg/cm ²)
Foam Filled	172 lb/in ² (12,1 kg/cm ²)
14.00 x 17.5	
Air Filled	125 lb/in ² (8,8 kg/cm ²)
Foam Filled	151 lb/in ² (10,6 kg/cm ²)

Declaration of Vibration (CE)

Average weighted whole body acceleration.

Mechanical Suspension Seat.....3.6 ft/s² (1,1 m/s²)

Noise Emission Level (CE)

- The telehandler is approved under the applicable EC directives.
- The LWA sound power level is shown on the machine.
TH255.....105 dB
- To avoid any increase in noise emission, after maintenance and repair work, all panels and other sound absorbing materials must be replaced in their original condition. Do not modify the machine in such a manner as to increase noise emissions.

This Page Intentionally Left Blank

A	E
Accessory Control Lever 3-18	Electrical Hazards 1-2
Additional Checks..... 8-1	Emergency Exit from
Adjusting/Moving Forks 5-15	Enclosed Cab..... 6-2
Air Conditioning System 9-2	Emergency Lowering of Boom..... 6-2
Attachment Installation	Emergency Procedures 6-1
Standard Quick Coupler..... 5-9	Engine
Universal Quick Coupler 5-12	Normal Operation 4-3
Attachment Operation 5-16	Starting 4-1
Attachments	Engine Coolant Level..... 7-16
Approved..... 5-1	Engine Crankcase Oil 9-2
JLG Supplied 5-2	Engine Oil Level..... 7-10
Unapproved 5-1	
Auto Hitch, Adjustable..... 5-31	F
Axles..... 9-2	Fall Hazard..... 1-12
	Fork Mounted Hook 5-19
B	Fuel Level 7-8
Battery 7-17	Fuel Tank 9-2
Boom Indicator	Fuel/Water Separator..... 7-9
Angle..... 3-22	
Extension 3-22	G
Brake Fluid Level..... 7-18	General Maintenance..... 7-2
Brake System 9-2	Grapple Bucket 5-26
Bucket 5-24	
	H
C	Hazard Classification System 1-1
Capacities..... 9-2	Hitches 5-29
Capacity 5-4	Hydraulic Oil Level 7-11
Capacity Indicator Locations 5-5	Hydraulic Operated Attachment..... 5-14
Carriage w/Forks 5-18	Hydraulic System 9-2
Chemical Hazards 1-13	
Cooling System 9-2	I
	Ignition 3-6
D	Instrument Panel..... 3-12
Decals	
ASME..... 2-4	J
ISO..... 2-6	Joystick
Dimensions..... 9-4	Lift Joystick Pattern 3-14
Disengaging a Load 4-6	Loader Joystick Pattern 3-15
Disengaging a Suspended Load 4-9	
Driving Hazards on Slopes..... 1-9	

Index

L	
Leveling Procedure.....	4-5, 4-8
Lifting Personnel.....	1-8
Load Chart	
Example	5-8
Sample (ANSI & CE).....	5-6
Sample (AUS)	5-7
Load Falling Hazard	1-7
LSI	3-8
Test	8-1
LSI Override Switch.....	3-11
Lubrication and Maintenance	7-1
Lubrication Schedule	
250 Hour	7-6
M	
Material Handling Arm.....	5-28
N	
Noise Emission.....	9-5
O	
Operating with a Non-Suspended Load.....	4-4
Operating with a Suspended Load ...	4-7
Operation.....	4-1
Operational Check.....	2-10
Operator Cab.....	2-11
Operator Maintenance Instructions	7-8
Operator Seat	3-20
P	
Park Brake.....	3-4
Parking Procedure.....	3-5
Performance	9-3
Picking Up a Suspended Load	4-7
Pin Hitch	5-29
Pin Hitch, Adjustable	5-30
Pinch Points and Crush Hazards....	1-10
Placing a Load.....	4-6
Placing a Suspended Load	4-9
Pre-Operation Check and Inspection.....	2-1
R	
Right Hand Console	3-16
Rotate/Side Tilt Carriage.....	5-20
S	
Safety Decals.....	2-4
Safety Practices	1-1
Safety Signal Words.....	1-1
Seat Belt.....	3-21
Service and Maintenance Schedule	
10 Hour	7-3
1000 Hour.....	7-5
1st 250 Hour	7-4
1st 50 Hour	7-3
250 Hour	7-4
50 Hour	7-3
500 Hour	7-4
Shut-Down Procedure.....	4-3
Side Shift Carriage	5-22
Specifications	9-1
Steer Modes.....	3-19
Steering Column Adjuster	3-13
T	
Tip Over Hazard.....	1-3
Tires	7-12, 9-2
Air Pressure	7-12
Damage	7-12
Replacement.....	7-12
Towing.....	6-1
Transmission Control Lever	3-7
Transport	
Lifting	4-12
Tiedown	4-11
Transporting a Load	4-5
Transporting a Suspended Load.....	4-8
Travel Hazard.....	1-6

V

Vibration 9-5

W

Walk-Around Inspection 2-8

Warm-Up 2-10

Wheel Lug Nut..... 9-2

Wheel Replacement 7-12

Windows..... 2-12

Windshield Washer Fluid Level 7-19



An Oshkosh Corporation Company

TRANSFER OF OWNERSHIP

To Product Owner:

If you now own but ARE NOT the original purchaser of the product covered by this manual, we would like to know who you are. For the purpose of receiving safety-related bulletins, it is very important to keep JLG Industries, Inc. updated with the current ownership of all JLG products. JLG maintains owner information for each JLG product and uses this information in cases where owner notification is necessary.

Please use this form to provide JLG with updated information with regard to the current ownership of JLG products. Please return completed form to the JLG Product Safety & Reliability Department via facsimile or mail to address as specified below.

Thank You,
Product Safety & Reliability Department
JLG Industries, Inc.
13224 Fountainhead Plaza
Hagerstown, MD 21742
USA
Telephone: +1-717-485-6591
Fax: +1-301-745-3713

NOTE: Leased or rented units should not be included on this form.

Mfg. Model: _____

Serial Number: _____

Previous Owner: _____

Address: _____

Country: _____ **Telephone:** (_____) _____

Date of Transfer: _____

Current Owner: _____

Address: _____





Country: _____ **Telephone:** (_____) _____

Who in your organization should we notify?

Name: _____

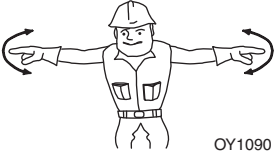
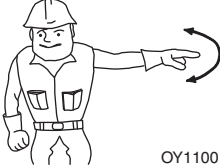
Title: _____

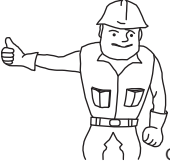
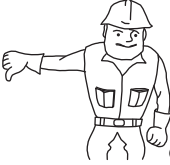
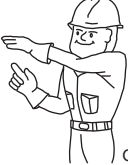
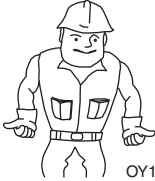
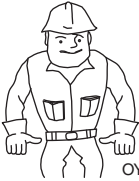
Hand Signals

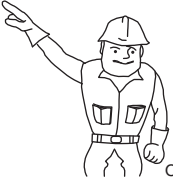
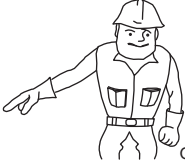
 <p>OY1090</p> <p>EMERGENCY STOP - With both arms extended laterally, hands open downward, move arms back and forth.</p>	 <p>OY1100</p> <p>STOP - With either arm extended laterally, hand open downward, move arm back and forth.</p>	 <p>OY1110</p> <p>STOP ENGINE - Draw thumb or forefinger across throat.</p>
 <p>OY1120</p> <p>RAISE BOOM - With either arm extended horizontally, fingers closed, point thumb upward.</p>	 <p>OY1130</p> <p>LOWER BOOM - With either arm extended horizontally, fingers closed, point thumb downward.</p>	 <p>OY1140</p> <p>MOVE SLOWLY - Place one hand motionless in front of hand giving motion signal. (Raise load slowly shown)</p>
 <p>OY1150</p> <p>EXTEND BOOM - With both hands clenched, point thumbs outward.</p>	 <p>OY1160</p> <p>RETRACT BOOM - With both hands clenched, point thumbs inward.</p>	 <p>OY1170</p> <p>THIS FAR TO GO - With hands raised and open inward, move hands laterally, indicating distance to go.</p>
 <p>OY1180</p> <p>TILT FORKS UP - With one arm held at side, extend other arm upward at about 45 degrees.</p>	 <p>OY1190</p> <p>TILT FORKS DOWN - With one arm held at side, extend other arm downward at about 45 degrees.</p>	

Special Signals - When signals for auxiliary equipment functions or conditions not covered are required, they shall be agreed upon in advance by the operator and signalman.



31200362

CATERPILLAR®