



Service and Repair Manual

Serial Number Range

GTH™-844

from GTH08E-11500
from GTH08T-14101

This manual includes:
Repair procedures
Fault Codes
Electrical and
Hydraulic Schematics

For detailed maintenance
procedures, refer to the
appropriate Maintenance
Manual for your machine.

Part No. 1288232GT
Rev B
September 2021

Introduction

Important

Read, understand and obey the safety rules and operating instructions in the appropriate Operator's Manual on your machine before attempting any procedure.

This manual provides troubleshooting and repair procedures for qualified service professionals.

Basic mechanical, hydraulic and electrical skills are required to perform most procedures. However, several procedures require specialized skills, tools, lifting equipment and a suitable workshop. In these instances, we strongly recommend that maintenance and repair be performed at an authorized Genie dealer service center.

Compliance

Machine Design Life

Unrestricted with proper operation, inspection and scheduled maintenance.

Technical Publications

Genie has endeavored to deliver the highest degree of accuracy possible. However, continuous improvement of our products is a Genie policy. Therefore, product specifications are subject to change without notice.

Readers are encouraged to notify Genie of errors and send in suggestions for improvement. All communications will be carefully considered for future printings of this and all other manuals.

Contact Us:

Internet: www.genielift.com
E-mail: awp.techpub@terex.com

Find a Manual for this Model

Go to <http://www.genielift.com>

Use the links to locate Service Manuals, Maintenance Manuals, Service and Repair Manuals, Parts Manuals and Operator's Manuals.

Copyright © 2016 by Terex Corporation

1288232GT Rev B, September 2021

First Edition, Second Printing

Genie is a registered trademark of Terex South Dakota, Inc. in the U.S.A. and many other countries.

"GTH" is a trademark of Terex South Dakota, Inc.

Introduction

Revision History

Revision	Date	Section	Procedure / Page / Description
A	4/2018		Initial Release
B	9/2021	Specification	Hydraulic Component Specifications Machine Component Weights
		Repair	2-1, 7-2, 7-3, 7-4
		Schematics	Harness Maps, Electrical, Hydraulic
Reference Examples:			Electronic Version Click on any content or procedure in the Table of Contents to view the update.
Section – Repair Procedure, 4-2			
Section – Fault Codes, All charts			
Section – Schematics, Legends and schematics			

Introduction

Serial Number Legend

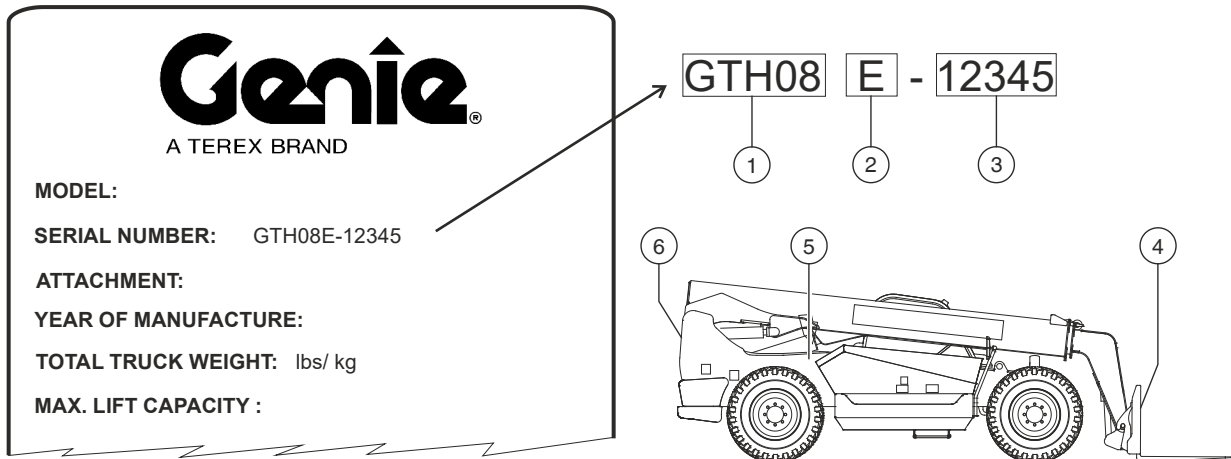

MODEL:
SERIAL NUMBER: GTH08E-12345
ATTACHMENT:
YEAR OF MANUFACTURE:
TOTAL TRUCK WEIGHT: lbs/ kg
MAX. LIFT CAPACITY :

- 1 Model
- 2 Facility code
- 3 Sequence number

- 4 Serial label (located inside fork frame)
- 5 Serial number (stamped on chassis)
- 6 Serial label (located inside riser, cab side)

Safety Rules



Danger

Failure to obey the instructions and safety rules in this manual and the appropriate Operator's Manual on your machine will result in death or serious injury.

Many of the hazards identified in the operator's manual are also safety hazards when maintenance and repair procedures are performed.

Do not modify or alter a Telehandler without prior written permission from the manufacturer.

Do Not Perform Maintenance Unless:

- You are trained and qualified to perform maintenance on this machine.
- You read, understand and obey:
 - manufacturer's instructions and safety rules
 - employer's safety rules and worksite regulations
 - applicable governmental regulations

You have the appropriate tools, lifting equipment and a suitable workshop.

Safety Rules

Personal Safety

Any person working on or around a machine must be aware of all known safety hazards. Personal safety and the continued safe operation of the machine should be your top priority.



Read each procedure thoroughly. This manual and the decals on the machine, use signal words to identify the following:



Safety alert symbol—used to alert personnel to potential personal injury hazards. Obey all safety messages that follow this symbol to avoid possible injury or death.



Indicates a imminently hazardous situation which, if not avoided, will result in death or serious injury.



Indicates a potentially hazardous situation which, if not avoided, could result in death or serious injury.



Indicates a potentially hazardous situation which, if not avoided, may cause minor or moderate injury.



Indicates a potentially hazardous situation which, if not avoided, may result in property damage.



Be sure to wear protective eye wear and other protective clothing if the situation warrants it.



Be aware of potential crushing hazards such as moving parts, free swinging or unsecured components when lifting or placing loads. Always wear approved steel-toed shoes.

Workplace Safety

Any person working on or around a machine must be aware of all known safety hazards. Personal safety and the continued safe operation of the machine should be your top priority.



Be sure to keep sparks, flames and lighted tobacco away from flammable and combustible materials like battery gases and engine fuels. Always have an approved fire extinguisher within easy reach.



Be sure that all tools and working areas are properly maintained and ready for use. Keep work surfaces clean and free of debris that could get into machine components and cause damage.



Be sure any forklift, overhead crane or other lifting or supporting device is fully capable of supporting and stabilizing the weight to be lifted. Use only chains or straps that are in good condition and of ample capacity.



Be sure that fasteners intended for one time use (i.e., cotter pins and self-locking nuts) are not reused. These components may fail if they are used a second time.



Be sure to properly dispose of old oil or other fluids. Use an approved container. Please be environmentally safe.



Be sure that your workshop or work area is properly ventilated and well lit.

Table of Contents

Introduction	Introduction ii
	Important Information ii
	Find a Manual for this Model ii
	Serial Number Legend iv
Section 1	Safety Rules v
	General Safety Rules v
Section 2	Specifications 1
	Machine Specifications..... 1
	Performance Specifications..... 2
	Hydraulic Oil Specifications..... 3
	Hydraulic Component Specifications..... 6
	Manifold Component Specifications..... 6
	Air Conditioner Refrigerant Specifications 6
	DEF Storage Specifications 6
	Machine Component Weights 7
	Deutz TCD3.6 L4 Engine Specifications 8
	Deutz TCD3.6 L4 T4F Engine Specifications..... 9
	Perkins 1104D-E44TA Engine Specifications 10
	Perkins 854E-E34TA Engine Specifications 11
	Dana VDT12000 Transmission Specifications 12
	Dana 212 Drive Axle 12
	Hydraulic Hose and Fitting Torque Specifications 13
	Torque Procedure 14

Table of Contents

Section 3	Repair Procedures	16
	Introduction	16
	Boom Components	18
	1-1 Boom Proximity Switch	18
	How to Test a Proximity Switch	18
	How to Adjust the Boom Angle Proximity Switch	19
	1-2 Boom.....	19
	How to Replace the Boom Wear Pads	19
	How to Remove the Lifting Fork Frame	20
	How to Replace the Retraction Chain	20
	How to Replace the Extension Chains	22
	How to Remove the Boom.....	23
	How to Disassemble the Boom.....	25
	1-3 Boom Lift Cylinder	27
	1-4 Boom Extension Cylinder	28
	1-5 Fork Level Cylinder	28
	1-6 Hydraulic Hoses.....	29
	How to Adjust the Fork Level Cylinder and/or Auxiliary Hose	29
	How to Replace the Fork Level Cylinder and/or Auxiliary Hoses	30
	Operator's Compartment.....	32
	2-1 Operator's Compartment	32
	2-2 Machine Controls.....	33
	How to Remove the Steering Column	33
	How to Remove the Steering Wheel	34
	How to Remove the Steer Orbital.....	34
	How to Remove the Joystick - Models with Electronic Joystick	35
	How to Remove the Brake Pedal Assembly	35
	How to Remove the Gauge Cluster Assembly	36
	Fuel and Hydraulic Tanks	37
	3-1 Fuel and Hydraulic Tanks	37

Table of Contents

Engines	39
4-1 Engines	39
How to Repair the Perkins 1104D-E44TA Engine	39
How to Repair the Perkins 854E-34TA Engine	39
How to Repair the Deutz TCD3.6 Engine	39
4-2 Engine Fault Codes.....	40
Transmission	41
5-1 Transmission	41
Hydraulic Pump	42
6-1 Hydraulic Pump	42
How to Test the Function Pump.....	42
How to Remove the Function Pump	43
How to Install the Function Pump	44
How to Prime the Function Pump	44
How to Adjust the Function Pump Standby Pressure	45
How to Adjust the Function Pump Pressure Compensator	46
Manifolds	47
7-1 PVG Manifold	47
7-2 Secondary Function Manifold Components	48
7-3 Brake Manifold Components	50
7-4 Valve Adjustments - Secondary Function Manifold	51
How to Set the Steer System Pressure	51
How to Set the Parking Brake System Pressure	52
How to Set the Rear Lock-up System Pressure	53
7-5 Valve Coils	54
Axle	56
8-1 Axles.....	56
<hr/>	
Section 4	
Fault Codes	57
Introduction.....	57
Diagnostic Display	58
Diagnostic Display.....	58
Deutz TCD3.6 Engine Fault Codes	59
Perkins 1104 Engine Fault Codes	83

Table of Contents

Section 5	Schematics	85
	Introduction	85
	Fuse Panel Layout	86
	Deutz TCD3.6 T4F Module	87
	Electrical Component & Wire Color Abbreviation Legend	88
	Electrical Symbol Legend	92
	Hydraulic Symbols Legend	93
	Harness Map Legend	94
	Electrical Schematics - Harness Maps	95
	Harness Map - Control System Ground Electronic Joystick	96
	Harness Map - Beacon, Proximity Alarm and 3rd Gear Lockout	97
	Harness Map - Deutz TCD3.6 Engine Battery Power and Ground	100
	Harness Map - Perkins Engine Battery Power and Ground	101
	Harness Map - Options Work Lights	104
	Harness Map - Options Road Lights	105
	Harness Map - Options Enclosed Cab with Heater	108
	Harness Map - Options Enclosed Cab with HVAC	109
	Electrical Schematics	111
	Electrical Schematic [from GTH08E-11500 to 13228]	112
	Electrical Schematic [from GTH08E-11500 to 13228]	113
	Electrical Schematic [from GTH08E-13229]	116
	Electrical Schematic [from GTH08E-13229]	117
	Electrical Schematic, Option [from GTH08E-13229]	120
	Electrical Schematic - Deutz T3 Eng Harness	121
	Electrical Schematic - Deutz T4F Eng Harness	124
	Electrical Schematic - Deutz T4F Eng Harness	125
	Electrical Schematic - Deutz T4F Eng Harness	128
	Hydraulic Schematics	129
	Hydraulic Schematic [from GTH08E-11500 to 13228]	130
	Hydraulic Schematic [from GTH08E-13229]	131

Specifications

Machine Specifications

Tires and wheels

Tire size	13.00 x 24
Tire ply rating	12
Weight, rough terrain tire (air filled)	315 lbs 142.9 kg
Weight, rough terrain tire (foam filled)	967 ±35 lbs 439 ±16 kg
Tire pressure (models with air-filled tires)	62 psi 4.3 bar
Lug nut torque	465 ft-lbs 630 Nm
Lug Pattern	8 x 10.826
Wheel diameter	24 in 60.1 cm
Wheel width	9 in 22.9 cm

Fluid capacities

Fuel tank	32 gallons 121.1 liters
Hydraulic tank	19 gallons 71.9 liters
Hydraulic system (including tank)	34 gallons 128.7 liters
DEF tank	2.6 gallons 10 liters

Specifications

Performance Specifications

Drive speed, maximum

Deutz TCD3.6 T3/T4F Engines	15 mph 24.1 km/h
-----------------------------	---------------------

Perkins 1104D Engine	14 mph 22.5 km/h
----------------------	---------------------

Perkins 854E T4i Engine	16 mph 25.7 mph
-------------------------	--------------------

Draw bar pull	21,000 lbs 9525 kg
----------------------	-----------------------

Lift capacity, maximum	8000 lbs 3629 kg
-------------------------------	---------------------

Boom function speeds, maximum

Boom up	12 to 14 seconds
---------	------------------

Boom down	9 to 11 seconds
-----------	-----------------

Boom extend	13 to 15 seconds
-------------	------------------

Boom retract	8 to 10 seconds
--------------	-----------------

Fork rotate	3 to 6 seconds
-------------	----------------

Fork tilt up	6 to 8 seconds
--------------	----------------

Fork tilt down	5 to 7 seconds
----------------	----------------

Specifications

Hydraulic Oil Specifications

Hydraulic Fluid Specifications

Genie specifications require hydraulic oils which are designed to give maximum protection to hydraulic systems, have the ability to perform over a wide temperature range, and the viscosity index should exceed 140. They should provide excellent antiwear, oxidation prevention, corrosion inhibition, seal conditioning, and foam and aeration suppression properties.

Cleanliness level, minimum	ISO 15/13
----------------------------	-----------

Water content, maximum	250 ppm
------------------------	---------

Recommended Hydraulic Fluid

Hydraulic oil type	Chevron Rando HD Premium
Viscosity grade	32
Viscosity index	200

Optional Hydraulic Fluids

Mineral based	Shell Tellus S2 V 32
	Shell Tellus S2 V 46
	Shell Tellus S4 VX 32
	Shell Donax TG (Dexron III)
	Chevron 5606A

Biodegradable	Petro Canada Environ MV 46
---------------	----------------------------

Fire resistant	UCON Hydrolube HP-5046
----------------	------------------------

Note: Genie specifications require additional equipment and special installation instructions for the approved optional fluids. Consult Genie Product Support before use.

NOTICE Optional fluids may not have the same hydraulic lifespan and may result in component damage.

Note: Extended machine operation can cause the hydraulic fluid temperature to increase beyond its maximum allowable range. If the hydraulic fluid temperature consistently exceeds 200°F / 90°C an optional oil cooler may be required.

NOTICE

Do not top off with incompatible hydraulic fluids. Hydraulic fluids may be incompatible due to the differences in base additive chemistry. When incompatible fluids are mixed, insoluble materials may form and deposit in the hydraulic system, plugging hydraulic lines, filters, control valves and may result in component damage.

Note: Do not operate the machine when the ambient air temperature is consistently above 120°F / 49°C.

Hydraulic Fluid Temperature Range

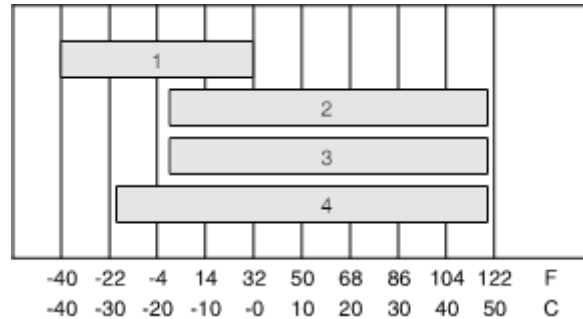

Ambient air temperature

- 1 Chevron hydraulic oil 5606A
- 2 Petro-Canada Environ MV 46
- 3 UCON Hydrolube HP-5046D
- 4 Chevron Rando HD premium oil MV

Specifications

Chevron Rando HD Premium Oil MV Fluid Properties

ISO Grade	32
Viscosity index	200
Kinematic Viscosity cSt @ 200°F / 100°C	7.5
cSt @ 104°F / 40°C	33.5
Brookfield Viscosity cP @ -4°F / -20°C	1040
cP @ -22°F / -30°C	3310
Flash point	375°F / 190°C
Pour point	-58°F / -50°C
Maximum continuous operating temperature	171°F / 77°C

Note: A hydraulic oil heating system is recommended when the ambient temperature is consistently below 0°F / -18°C.

Note: Do not operate the machine when the ambient temperature is below -20°F / -29°C with Rando HD Premium MV.

Chevron 5606A Hydraulic Oil Fluid Properties

ISO Grade	15
Viscosity index	300
Kinematic Viscosity cSt @ 200°F / 100°C	5.5
cSt @ 104°F / 40°C	15.0
cSt @ -40°F / -40°C	510
Flash point	180°F / 82°C
Pour point	-81°F / -63°C
Maximum continuous operating temperature	124°F / 51°C

Note: Use of Chevron 5606A hydraulic fluid, or equivalent, is required when ambient temperatures are consistently below 0°F / -17°C unless an oil heating system is used.

NOTICE

Continued use of Chevron 5606A hydraulic fluid, or equivalent, when ambient temperatures are consistently above 32°F / 0°C may result in component damage

Specifications

Petro-Canada Environ MV 46 Fluid Properties

ISO Grade	46
Viscosity index	154
Kinematic Viscosity	
cSt @ 200°F / 100°C	8.0
cSt @ 104°F / 40°C	44.4
Flash point	482°F / 250°C
Pour point	-49°F / -45°C
Maximum continuous operating temperature	180°F / 82°C

Shell Tellus S4 VX Fluid Properties

ISO Grade	32
Viscosity index	300
Kinematic Viscosity	
cSt @ 200°F / 100°C	9
cSt @ 104°F / 40°C	33.8
Brookfield Viscosity	
cSt @ -4°F / -20°C	481
cSt @ -13°F / -25°C	702.4
cSt @ -40°F / -40°C	2624
Flash point	>100
Pour point	-76°F / -60°C
Maximum continuous operating temperature	103°F / 75°C

UCON Hydrolube HP-5046 Fluid Properties

ISO Grade	46
Viscosity index	192
Kinematic Viscosity	
cSt @ 149°F / 65°C	22
cSt @ 104°F / 40°C	46
cSt @ 0°F / -18°C	1300
Flash point	None
Pour point	-81°F / -63°C
Maximum continuous operating temperature	189°F / 87°C

Specifications

Hydraulic Component Specifications

Function pump

Type: variable displacement piston pump	
Displacement	0 to 3.1 cu in 0 to 51 cc
Flow rate @ 2500 rpm	34 gpm 128 L/min
Pump pressure, maximum	3190 psi 220 bar
Pressure compensator	3190 psi 220 bar
Standby pressure	450 psi 31 bar

Primary Function Manifold

System relief valve pressure, maximum (measured at test port TP)	3200 psi 221 bar
Fork tilt relief valve pressure, maximum	3500 psi 241 bar
Flow regulator, Sway circuit	2 gpm 7.5 L/min

Secondary Function Manifold

Steer relief valve pressure, maximum (measured at test port TS)	2650 psi 182.7 bar
Parking brake relief valve pressure, maximum (measured at test port TPB)	350 psi 24.1 bar
Diff lock relief valve pressure, maximum (measured at test port TJ)	250 psi 17.2 bar
Rear lock-up relief valve pressure, maximum (measured at test port TR)	50 psi 3.4 bar

Manifold Component Specifications

Plug torque

SAE No. 2	50 in-lbs / 6 Nm
SAE No. 4	13 ft-lbs / 18 Nm
SAE No. 5	15 ft lbs / 20 Nm
SAE No. 6	18 ft-lbs / 24 Nm
SAE No. 8	50 ft-lbs / 68 Nm
SAE No. 10	55 ft-lbs / 75 Nm
SAE No. 12	75 ft-lbs / 102 Nm

Air Conditioner Refrigerant Specifications

System Full Charge

R134a	1 lb 14 oz
-------	------------

DEF Storage Specifications

Diesel Exhaust Fluid decomposes when exposed to elevated temperatures for an extended period of time. Therefore precautions must be taken to avoid prolonged exposure to elevated temperatures.

Temperature	Estimated Useful Life
32°F / 0°C	Indefinite
50°F / 10°C	75 years
68°F / 20°C	11 years
86°F / 30°C	23 months
95°F / 35°C	10 months
104°F / 40°C	4 months
122°F / 50°C	1 month
140°F / 60°C	1 week

Specifications

Machine Component Weights

Primary boom	6062 lbs 2750 kg
Primary boom lift cylinder	622 lbs 282 kg
Primary boom extend cylinder	438 lbs 199 kg
Counterweight (each)	1231 lbs 558 kg
Drive chassis assembly	4732 lbs 2146 kg
Transmission	371 lbs 168 kg
Axle	1248 lbs 566 kg

Specifications

Deutz TCD3.6 L4 Engine

Displacement	221 cu in 3.62 liters
Number of cylinders	4
Bore and Stroke	3.86 x 4.72 inches 98 x 120 mm
Horsepower T4i	99 @ 2300 rpm 73.8 kw @ 2300 rpm
Peak Torque T4i	288 lb-ft @ 1600 rpm 390 Nm @ 1600 rpm
Horsepower T4F	74 @ 2300 rpm 55.2 kw @ 2300 rpm
Peak Torque T4F	288 lb-ft @ 1300 rpm 390 Nm @ 1300 rpm
Firing order	1 - 3 - 4 - 2 -
Low idle	1000 rpm
Frequency	200 Hz
High idle	2400 rpm
Frequency	500 Hz
Compression ratio	17.2:1
Compression pressure (psi or bar) of the lowest cylinder must be at least 75% of the highest cylinder	
Governor	electronic
Lubrication system	
Minimum oil pressure (warm, at low idle)	23.5 psi 1.6 bar
Oil capacity (including filter) Low Emission Oil	9.5 quarts 9 liters

Oil viscosity requirements

Unit ships with 15W-40 API CJ4 low ash oil. Extreme operating temperatures may require the use of alternative engine oils. For oil requirements, refer to the Engine Operator Manual for your engine.

Fuel injection system

Injection pump pressure, maximum	23200 psi 1600 bar
----------------------------------	-----------------------

Fuel requirement

For fuel requirements, refer to the engine Operator Manual for your engine.

Engine coolant

Capacity	4.5 gallons 17 liters
Type	Extended Life

Starter motor

Normal load	300-400A
Relay max	60A
Relay continuous	12A
Cranking speed	>100 rpm

Glow Plugs

Initial load (0-6 sec)	80 amps
Continuous load (>6 sec)	<40 amps

Battery Specifications

Type	12V DC
Group	C31
Quantity	1
Battery capacity, maximum	1000A
Reserve capacity @ 25A rate	200 Minutes

Alternator output	95A @ 12V DC
--------------------------	--------------

Specifications

Deutz TCD3.6 L4 T4F Engine

Displacement	221 cu in 3.62 liters
Number of cylinders	4
Bore and Stroke	3.86 x 4.72 inches 98 x 120 mm
Horsepower	100 @ 2300 rpm 74.6 kw @ 2300 rpm
Peak Torque	302 lb-ft @ 1600 rpm 409 Nm @ 1600 rpm
Firing order	1 - 3 - 4 - 2
Induction System	turbocharged charge air cooled
Aftertreatment	DOC + SCR
Combustion	direct injection 252 cfm / 0.18 cmm
Exhaust	703 cfm @ 2300 rpm 894°F / 470°C @ 2300 rpm
Low idle Frequency	1000 rpm 200 Hz
High idle Frequency	2400 rpm 500 Hz
Compression ratio	17.2:1
Compression pressure (psi or bar) of the lowest cylinder must be at least 75% of the highest cylinder	
Governor	electronic
Lubrication system	
Minimum oil pressure (warm, at low idle)	23.5 psi 1.6 bar
Oil capacity (including filter)	9.5 quarts 9 liters
Low Emission Oil	
Oil viscosity requirements	
Unit ships with 15W-40 API CJ4 low ash oil. Extreme operating temperatures may require the use of alternative engine oils. For oil requirements, refer to the Engine Operator Manual for your engine.	

Fuel injection system

Injection pump pressure, maximum	23200 psi 1600 bar
Max fuel consumption	6.5 gph / 24.6 lph

Fuel requirement

For fuel requirements, refer to the engine Operator Manual for your engine.

Engine coolant

Capacity	4.5 gallons 17 liters
Type	Extended Life

Starter motor

Normal load	300-400A
Relay max	60A
Relay continuous	12A
Cranking speed	>100 rpm

Glow Plugs

Initial load (0-6 sec)	80 amps
Continuous load (>6 sec)	<40 amps

Battery Specifications

Type	12V DC
Group	C31
Quantity	1
Battery capacity, maximum	1000A
Reserve capacity @ 25A rate	200 Minutes

Alternator output 120A @ 12V DC

Specifications

Perkins 1104D-E44TA Engine

Displacement	269 cu. in 4.4 liters
Number of cylinders	4
Bore and Stroke	4.13 x 5 inches 105 x 127 mm
Horsepower	99 @ 2200 rpm 73.8 kW @ 2200 rpm
Peak Torque	310 lb-ft @ 1400 rpm 420 Nm @ 1400 rpm
Induction system	turbocharged
Firing order	1 - 3 - 4 - 2
Low idle	1000 rpm
Frequency	200 Hz
High idle	2500 rpm
Frequency	500 Hz
Compression ratio	16.2:1
Combustion	E-TVCS
Governor	Electronic
Lubrication system	
Oil pressure, hot (@ 2300 rpm)	43 to 58 psi 2.9 to 4 bar
Oil capacity (including filter)	10 quarts 9.6 liters

Oil viscosity requirements

Unit ships with 15W-40. Extreme operating temperatures may require the use of alternative engine oils. For oil requirements, refer to the Engine Operator Manual for your engine.

Fuel requirement

For fuel requirements, refer to the engine Operator Manual for your engine.

Fuel injection pressure	23700 psi 1635 bar
--------------------------------	-----------------------

Starter motor

Normal load	68A
Relay max	50A
Relay continuous	20A
Cranking speed	130 - 200 rpm

Battery Specifications

Type	12V DC, Group C31
Quantity	1
Battery capacity, maximum	1000A
Reserve capacity @ 25A rate	200 Minutes

Engine coolant

Capacity	4.6 gallons 17.4 liters
Type	Extended Life

Glow Plugs

Initial load (0-4 sec)	20A (EA)
Continuous load (>4 sec)	15A (EA)

Alternator output	85A @ 12V DC
--------------------------	--------------

Specifications

Perkins 854E-E34TA Engine

Displacement	207 cu. in 3.4 liters
Number of cylinders	4
Bore and Stroke	3.9 x 4.3 inches 99 x 110 mm
Horsepower	99 @ 2500 rpm 73.8 kW @ 2500 rpm
Peak Torque	288 lb-ft @ 1400 rpm 390 Nm @ 1400 rpm
Firing order	1 - 3 - 4 - 2
Low idle Frequency	1000 rpm 100 Hz
High idle Frequency	2700 rpm 270 Hz
Compression ratio	17.0:1
Compression pressure (psi or bar) of the lowest cylinder must be at least 75% of the highest cylinder	
Governor	Electronic
Lubrication system	
Minimum oil pressure	12 psi 0.82 bar
Oil capacity (including filter)	8.8 quarts 8.3 liters

Oil viscosity requirements

Units ship with 15W-40 API CJ4 low ash oil. Extreme operating temperatures may require the use of alternative engine oils. For oil requirements, refer to the Engine Operation and Maintenance Manual on your machine.

Fuel injection system

Injection pressure	23000 psi / (1600 bar)
--------------------	---------------------------

Fuel requirement

For fuel requirements, refer to the engine Operator Manual for your engine.

Glow plugs

Initial load (0-10 sec)	80A
Continuous load (>10 sec)	40A

Starter motor

Normal load	68A
Relay max	50A
Relay continuous	20A
Cranking speed	130 - 200 rpm

Battery Specifications

Type	12V DC, Group C31
Quantity	1
Battery capacity, maximum	1000A
Reserve capacity @ 25A rate	200 Minutes

Engine coolant

Capacity	4.9 gallons 18.5 liters
Type	Extended Life

Alternator output	120A @ 12V DC
--------------------------	---------------

Specifications

Dana VDT12000 Transmission Specifications

Transmission Type	3 speed powershift converter
Speeds, Forward	3
Speeds, Reverse	3
Torque Converter	
Maximum input	3100 rpm
Size	12 inches
Lubrication	
Oil capacity, transmission	14.3 quarts 13.5 liters
Oil capacity, drop box	1.1 quart 1 liter
Oil viscosity requirements	
Units ship with Chevron Ursa Hydraulic 10W. Extreme operating temperatures may require the use of alternative transmission oils. For oil requirements, refer to the Dana VDT12000 Service Manual.	
Dana VDT12000 Service Manual	
Genie part number	218706

Dana 212 Drive Axle Specifications

Steering	Integrated steer cylinder
Joints	Heavy duty double U-joints
Steering angle, maximum	45°
Front Axle Lubrication	
Front differential	7.4 quarts 7.0 liters
Axle planetary end (each)	2.2 quarts 2.1 liters
Rear Axle Lubrication	
Rear differential	8.2 quarts 7.8 liters
Axle planetary end (each)	1.5 quarts 1.4 liters
Oil viscosity requirements	
Differential	Chevron Supreme 85W90 (API GL5)
Planetary ends	Chevron Supreme 85W90 (API GL5)
For additional axle information, refer to the Dana 212 Axle Service Manual.	
Dana 212 Axle Service Manual	
Genie part number	1259569

Specifications

Hydraulic Hose and Fitting Torque Specifications

Your machine is equipped with Parker Seal-Lok™ ORFS or 37° JIC fittings and hose ends. Genie specifications require that fittings and hose ends be torqued to specification when they are removed and installed or when new hoses or fittings are installed.

Seal-Lok™ Fittings

(hose end - ORFS)

SAE Dash Size	Torque
-4	10 ft-lbs / 13.6 Nm
-6	30 ft-lbs / 40.7 Nm
-8	40 ft-lbs / 54.2 Nm
-10	60 ft-lbs / 81.3 Nm
-12	85 ft-lbs / 115 Nm
-16	110 ft-lbs / 150 Nm
-20	140 ft-lbs / 190 Nm
-24	180 ft-lbs / 245 Nm

JIC 37° Fittings

(swivel nut or hose connection)

SAE Dash Size	Thread Size	Flats
-4	7/16-20	2
-6	9/16-18	1 ¼
-8	3/4-16	1
-10	7/8-14	1
-12	1 1/16-12	1
-16	1 5/16-12	1
-20	1 5/8-12	1
-24	1 7/8-12	1

SAE O-ring Boss Port

(tube fitting - installed into Aluminum)
(all types)

SAE Dash Size	Torque
-4	14 ft-lbs / 19 Nm
-6	23 ft-lbs / 31.2 Nm
-8	36 ft-lbs / 54.2 Nm
-10	62 ft-lbs / 84 Nm
-12	84 ft-lbs / 114 Nm
-16	125 ft-lbs / 169.5 Nm
-20	151 ft-lbs / 204.7 Nm
-24	184 ft-lbs / 249.5 Nm

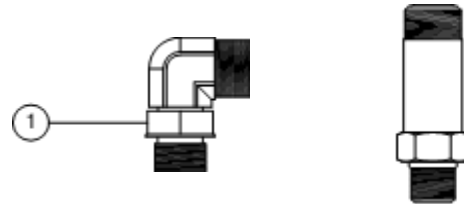

Adjustable Fitting

Non-adjustable fitting

1 jam nut

SAE O-ring Boss Port

(tube fitting - installed into Steel)

SAE Dash Size	Torque
-4	ORFS / 37° (Adj) 15 ft-lbs / 20.3 Nm ORFS (Non-adj) 26 ft-lbs / 35.3 Nm 37° (Non-adj) 22 ft-lbs / 30 Nm
-5	ORFS (Adj / Non adj) 32 ft lbs / 43.4 Nm
-6	ORFS (Adj / Non-adj) 35 ft-lbs / 47.5 Nm 37° (Adj / Non-adj) 29 ft-lbs / 39.3 Nm
-8	ORFS (Adj / Non-adj) 60 ft-lbs / 81.3 Nm 37° (Adj / Non-adj) 52 ft-lbs / 70.5 Nm
-10	ORFS (Adj / Non-adj) 100 ft-lbs / 135.6 Nm 37° (Adj / Non-adj) 85 ft-lbs / 115.3 Nm
-12	(All types) 135 ft-lbs / 183 Nm
-16	(All types) 200 ft-lbs / 271.2 Nm
-20	(All types) 250 ft-lbs / 339 Nm
-24	(All types) 305 ft-lbs / 413.5 Nm

Specifications

Torque Procedure

Seal-Lok™ fittings

- 1 Replace the O-ring. The O-ring must be replaced anytime the seal has been broken. The O-ring cannot be re-used if the fitting or hose end has been tightened beyond finger tight.

Note: The O-ring in Parker Seal Lok™ fittings and hose end are custom-size O-rings. They are not standard size O-rings. They are available in the O-ring field service kit (Genie part number 49612).

- 2 Lubricate the O-ring before installation.
- 3 Be sure the O-ring face seal is seated and retained properly.
- 4 Position the tube and nut squarely on the face seal end of the fitting, and tighten the nut finger tight.
- 5 Tighten the nut or fitting to the appropriate torque. Refer to the appropriate torque chart in this section.
- 6 Operate all machine functions and inspect the hose, fittings and related components to confirm there are no leaks.

JIC 37° fittings

- 1 Align the tube flare (hex nut) against the nose of the fitting body (body hex fitting) and tighten the hex nut to the body hex fitting to hand tight, approximately 30 in-lbs / 3.4 Nm.
- 2 Using a permanent ink marker, make a reference mark on one the flats of the hex nut and continue the mark onto the body of the hex fitting. Refer to Illustration 1.

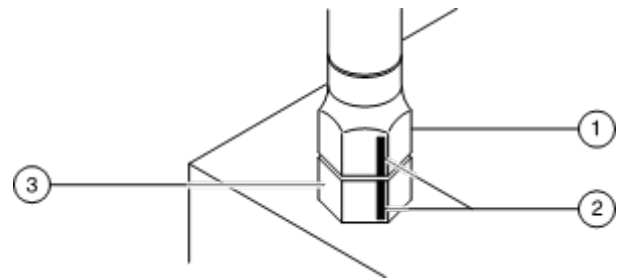

Illustration 1

- 1 hex nut
- 2 reference mark
- 3 body hex fitting

Specifications

- 3 Working clockwise on the body hex fitting, make a second mark with a permanent ink marker to indicate the proper tightening position. Refer to Illustration 2.

Note: Use the JIC 37° Fitting table in this section to determine the correct number of flats, for the proper tightening position.

Note: The marks indicate the correct tightening positions have been determined. Use the second mark on the body hex fitting to properly tighten the joint after it has been loosened.

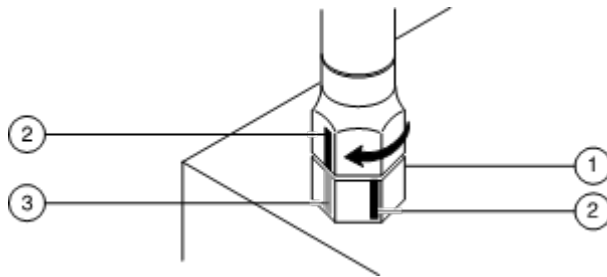

Illustration 2

- 1 body hex fitting
 - 2 reference mark
 - 3 second mark
- 4 Tighten the hex nut until the mark on the hex nut is aligned with the second mark on the body hex fitting.
 - 5 Operate all machine functions and inspect the hose, fittings and related components to confirm there are no leaks.

Repair Procedures



Observe and Obey:

- Repair procedures shall be completed by a person trained and qualified on the repair of this machine.
- Immediately tag and remove from service a damaged or malfunctioning machine.
- Repair any machine damage or malfunction before operating the machine.

Before Repairs Start:

- Read, understand and obey the safety rules and operating instructions in the appropriate operator's manual on your machine.
- Be sure that all necessary tools and parts are available and ready for use.
- Use only Genie approved replacement parts.
- Read each procedure completely and adhere to the instructions. Attempting shortcuts may produce hazardous conditions.

Machine Configuration:

- Unless otherwise specified, perform each repair procedure with the machine in the following configuration:
 - Machine parked on a firm, level surface
 - Boom in the stowed position
 - Key switch in the off position with the key removed
 - Wheels chocked

Repair Procedures

About This Section

Most of the procedures in this section should only be performed by trained service professional in a suitably equipped workshop. Select the appropriate repair procedure after troubleshooting the problem.

Perform disassembly procedures to the point where repairs can be completed. Then to re-assemble, perform the disassembly steps in reverse order.

Symbols Legend



Safety alert symbol—used to alert personnel to potential personal injury hazards. Obey all safety messages that follow this symbol to avoid possible injury or death.



Indicates a imminently hazardous situation which, if not avoided, will result in death or serious injury.



Indicates a potentially hazardous situation which, if not avoided, could result in death or serious injury.



Indicates a potentially hazardous situation which, if not avoided, may cause minor or moderate injury.



Indicates a potentially hazardous situation which, if not avoided, may result in property damage.

- ⊙ Indicates that a specific result is expected after performing a series of steps.
- ⊗ Indicates that an incorrect result has occurred after performing a series of steps.

Boom Components

1-1 Boom Proximity Switch

The boom angle switch is a proximity switch. This switch functions by sensing a change in the electromagnetic field of the switch, due to the introduction of metal into the field. A proximity switch is, simply, a metal detector.

The switch generates an electromagnetic field at the face of the switch. This field senses when steel has been moved close to the switch as well as when the steel has been moved away, which is how the switch contacts open and close.

These switches are of a fail-safe design. Should the switch or the switch wire circuit be faulty, the machine will not function outside its designed range of use.

The boom proximity switch is a component of the drive circuit and the chassis sway circuit. Both the drive and the chassis sway functions are disabled when the boom is raised to 60° or higher.

How to Test a Proximity Switch

- 1 Remove the switch from the machine. Do not disconnect the switch wire harness from the machine.
- 2 Start the engine.
- 3 Move the switch away from any ferrous or metallic object
 - ⊙ Result: The light of the limit switch assembly is not illuminated.
- 4 Move the switch close to any ferrous or metallic object
 - ⊙ Result: The light of the proximity switch assembly turns on. The switch is functioning correctly.

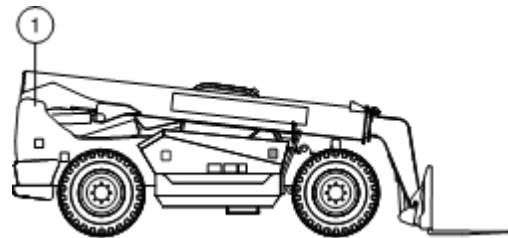

1 boom angle proximity switch (located on engine side)

Boom Components

How to Adjust the Boom Angle Proximity Switch

The boom angle proximity switch is attached to a mounting bracket, located between the boom and the chassis directly beneath the boom pivot pin. The switch location is adjustable.

- 1 Start the engine.
- 2 Raise the boom to 60°. Confirm with a digital level.
- 3 Working at the pivot end of the boom, locate the boom angle proximity switch. Loosen the fasteners, securing the proximity switch assembly to the chassis, just enough to allow the bracket to move.
- 4 Move the proximity switch assembly until the light of the proximity switch turns on, then move the proximity switch assembly until the light of the proximity switch just turns off.
- 5 Securely tighten the fasteners. Do not over tighten.
- 6 Lower the machine to 55°.
 - ⦿ Result: The light of the proximity switch assembly is illuminated.
- 7 Raise the boom to 60°. Confirm with a digital level.
 - ⦿ Result: The light of the proximity switch assembly is not illuminated. The proximity switch is properly calibrated.
 - ⊗ Result: The light of the proximity switch assembly is illuminated. The proximity switch is not calibrated correctly. Repeat this procedure beginning with step 4.

1-2 Boom

How to Replace the Boom Wear Pads

- 1 **Lower wear pads:** Using a lifting strap from an overhead crane or a fork lift of sufficient capacity, lift the boom tube just enough to remove the weight from the pads.
- 2 Remove the wear pad retainer plates and remove the wear pads from the boom.
- 3 Lubricate the wear surface of the new pads. Refer to Maintenance Procedure, *Lubricate the Boom*.

Note: Do not lubricate the side wear pads.

- 4 Install the wear pads. Install and securely tighten the retainer plates. Do not over tighten.

Boom Components

How to Remove the Lifting Fork Frame

- 1 With the boom in the stowed position, attach a lifting strap from an overhead crane to the top of the lifting fork frame at the front of the boom. Support the frame. Do not apply any lifting pressure.
- 2 Working from the rear of the frame, lift the spring-assisted handle of the lock securing the lower fork frame lock pin to the fork frame mount. Use a soft metal drift to remove the pin.
- 3 Using the overhead crane, lift and remove the fork frame from the boom.

CAUTION Crushing hazard. The fork frame could fall if not properly supported when the lock pin is removed from the machine.

How to Replace the Retraction Chain

Note: Perform this procedure on a firm, level surface with the boom in the stowed position and the wheels chocked.

- 1 Start the engine and allow the engine to idle.
- 2 Raise the boom to a horizontal position.
- 3 Fully retract the boom.
- 4 Extend the boom approximately 1 inch / 2.5 cm.
- 5 Turn the machine off and remove the key from the key switch.
- 6 Working at the fork end of the boom, remove the fasteners securing the single-chain anchor to the top of boom tube number 1.

Note: When installing the new chain, the chain tensioner should be mounted in the two most rearward holes.

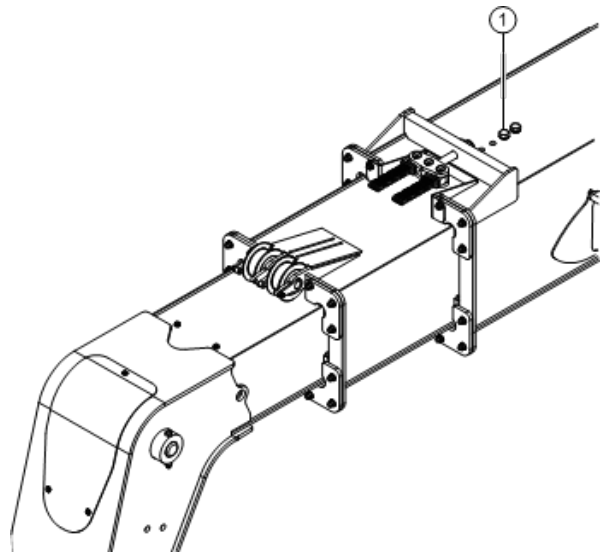

1 retract chain anchor

Boom Components

- 7 Remove the inspection cover from the pivot end of the boom. Locate the chain anchor of the boom retraction chain where it attaches to the chain anchor mount at the lower side of boom tube 3.

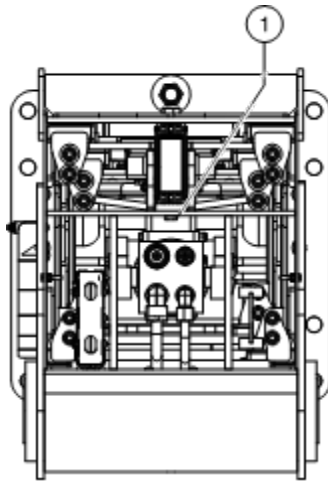

1 retract chain anchor

- 8 Remove a cotter pin securing the chain anchor pivot pin to the anchor mount of the boom tube. Remove the pivot pin and pull the chain free of the mount.
- 9 Working at the pivot end of the boom, pull the chain out of the boom.
- 10 Remove the chain anchor from the chain and install it on the new chain.
- 11 Feed an electrical 'fish tape' through the boom from the front and attach it to the new chain. Also attach a short rope to the pivot end of the chain.
- 12 Working at the fork end of the boom, use the tape to carefully pull the chain through the boom just until the end of the chain is accessible. Remove the tape from the chain.
- 13 Now pull the chain carefully toward the pivot end until the mounting holes of the chain anchor line up with the holes on the boom tube. Install the fasteners securing the chain to the bottom of the boom tube.
- 14 Working at the pivot end of the boom, route the chain over the roller and install the chain onto the boom assembly using the pivot pin and retaining clip removed in step 8.
- 15 Check the tension on the extension chains. Refer to Maintenance Procedure, *Adjust the Boom Sequencing Chains*.

NOTICE

Component damage hazard. Chains can be damaged if the boom is used while the chains are out of adjustment. Do not return the machine to use until the chains have been correctly adjusted.

Note: Always use new cotter pins when installing a chain

- 11 Feed an electrical 'fish tape' through the boom from the front and attach it to the new chain. Also attach a short rope to the pivot end of the chain.
- 12 Working at the fork end of the boom, use the tape to carefully pull the chain through the boom just until the end of the chain is accessible. Remove the tape from the chain.

Boom Components

How to Replace the Extension Chains

Note: Perform this procedure on a firm, level surface with the boom in the stowed position and the wheels chocked.

- 1 Start the engine and allow the engine to idle.
- 2 Raise the boom to a horizontal position.
- 3 Fully retract the boom.
- 4 Turn the machine off and remove the key from the key switch.
- 5 Working at the fork end of the boom, loosen the fasteners securing the single-chain tensioners to the top of boom tube number 1. After noting the orientation and assembly order of the components, remove the fasteners and pull the tensioners free of the boom. Refer to Illustration 1.

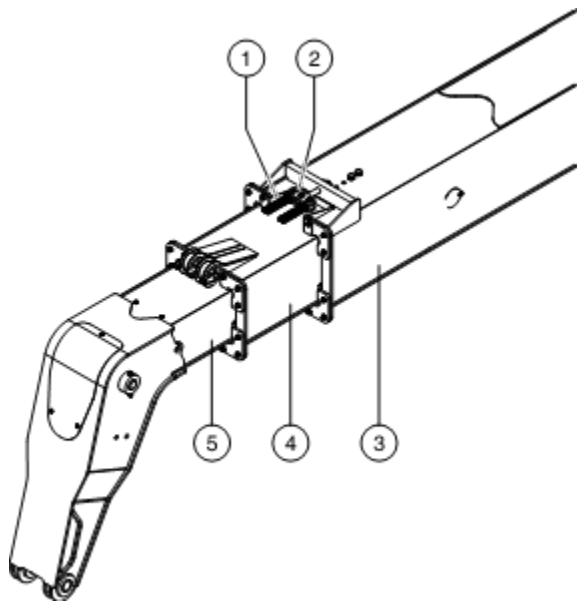

- 1 extension chains
- 2 single-chain tensioner
- 3 boom tube number 1
- 4 boom tube number 2
- 5 boom tube number 3

- 6 Select a chain tensioner. Remove the bow tie clip securing the chain anchor pin to the chain assembly. Remove the chain anchor pin from the assembly and remove the chain anchor from the tensioner assembly.
- 7 Repeat this procedure, beginning with step 6, for the other chains.
- 8 Working at the fork end of the boom, select a chain. Securely connect a 30 foot / 10 m length of rope to the end of the chain. Securely tie off the other end of the rope to the boom structure.
- 9 Remove the inspection cover from the pivot end of the boom and locate the chain anchors of the extension chains at the top of boom tube 3.
- 10 Remove the fasteners securing the extension chain anchors to the boom tubes.
- 11 Working at the pivot end of the boom, pull the chain out of the boom.

Note: Rope coming loose from the chain during removal may result in a difficult reassembly. Be sure the rope is securely attached to the chain and boom structure before pulling the chain out of the boom.

- 12 On a workbench, remove the bow tie clip securing the chain anchor pin to the chain assembly. Remove the pin and chain anchor pin from the assembly.
- 13 Install the chain anchor, pin and clip onto the new chain.
- 14 Remove the rope from the end of the old chain and securely attach the rope to the new chain.

Boom Components

- 15 Working at the fork end of the boom, use the rope to carefully pull the chain through the boom just until the end of the chain is accessible.
- 16 Working at the pivot end of the boom and using the fasteners removed in step 5, install the chain anchor onto the boom tube. Securely tighten the fasteners. Do not over tighten.
- 17 Remove the rope from the chain and install the chain into the chain anchor of the tensioner assembly. Secure the chain to the chain anchor using the pin and clip removed in step 6.
- 18 Repeat this procedure, beginning with step 5, for the other chains.
- 19 Install the inspection cover, removed in step 9, onto the boom. Install and securely tighten the fasteners. Do not over tighten.
- 20 Install the chain tensioners into the tensioner mount at the fork end of boom tube number 1. Install the mounting components, removed in step 6. Evenly tighten the chain tensioners to the top of the boom tube until they are securely tightened.
- 21 Adjust the chains. Refer to Maintenance, *Adjust the Boom Sequencing Chains*.

NOTICE

Component damage hazard. Chains can be damaged if the boom is used while the chains are out of adjustment. Do not return the machine to use until the chains have been correctly adjusted.

How to Remove the Boom

▲ WARNING

Bodily injury hazard. This procedure requires specific repair skills, lifting equipment and a suitable workshop. Attempting this procedure without these skills and tools could result in death or serious injury and significant component damage. Dealer service is strongly recommended.

Note: When removing a hose assembly or fitting, the O-ring (if equipped) on the fitting and/or hose end must be replaced. All connections must be torqued to specification during installation. Refer to Specifications, *Hydraulic Hose and Fitting Torque Specifications*.

- 1 Remove the lifting fork and frame. Refer to Repair Procedure, *How to Remove the Lifting Fork Frame*.
- 2 Attach a lifting strap from an overhead 10 ton / 10,000 kg crane to the fork end of the boom. Support the boom. Do not apply any lifting pressure.
- 3 Select a fork level cylinder. Remove the fasteners securing the fork level cylinder rod-end pivot pin to the boom.
- 4 Using a lifting strap from another overhead crane, support the rod-end of the fork level cylinder. Do not apply any lifting pressure.
- 5 Use a soft metal drift to remove the fork level cylinder pivot pin.

Boom Components

- 6 Lower the fork level cylinder onto the chassis.

▲ WARNING Crushing hazard. Keep hands clear of the cylinder manifold when lowering the cylinder.

- 7 Repeat this procedure beginning with step 3 for the other fork level cylinder.
- 8 Identify the hydraulic hoses from the lift cylinder. Tag, disconnect and plug the hoses at the lift cylinder manifold. Cap the fittings on the cylinder manifold.
- 9 Remove the fasteners securing the lift cylinder barrel-end pivot pin to the chassis.
- 10 Support and secure the barrel end of the lift cylinder to the boom.
- 11 Use a soft metal drift to remove the lift cylinder pivot pin.
- 12 Tag, disconnect and plug the hydraulic hoses at the hydraulic hard line connections at the pivot end of the boom. Cap the fittings.
- 13 Using the overhead crane, raise the boom to a horizontal position.

▲ WARNING Crushing hazard. The lift cylinder will fall if not properly supported when the boom is raised.

- 14 Remove the fasteners securing the boom pivot pin to the chassis.

- 15 Using a suitable tool, remove the boom pivot pin.

▲ DANGER Crushing hazard. The boom will fall if not properly supported when the pivot pin is removed from the machine.

- 16 Carefully remove the boom assembly from the machine and place it on a structure capable of supporting it.

▲ DANGER Crushing hazard. The boom could become unbalanced and fall if not properly supported when removed from the machine.

NOTICE Component damage hazard. The weight of the boom assembly may crush the hydraulic hard lines under the boom. Use caution when placing the boom assembly onto a structure capable of supporting it.

Boom Components

How to Disassemble the Boom

▲ WARNING Bodily injury hazard. This procedure requires specific repair skills, lifting equipment and a suitable workshop. Attempting this procedure without these skills and tools could result in death or serious injury and significant component damage. Dealer service is strongly recommended.

Note: When removing a hose assembly or fitting, the O-ring (if equipped) on the fitting and/or hose end must be replaced. All connections must be torqued to specification during installation. Refer to Specifications, *Hydraulic Hose and Fitting Torque Specifications*.

- 1 Remove the extension cylinder. Refer to Repair Procedure, *How to Remove the Extension Cylinder*.
- 2 Remove the boom. Refer to Repair Procedure, *How to Remove the Boom*.
- 3 Select a lift cylinder. Remove the fasteners securing the lift cylinder rod-end pivot pin to the boom.
- 4 Using a lifting strap from an overhead crane, support the lift cylinder. Do not apply any lifting pressure.
- 5 Use a soft metal drift to remove the lift cylinder rod-end pivot pin. Remove the cylinder from the boom.

▲ WARNING Crushing hazard. The cylinder could become unbalanced and fall if not properly supported when removed from the machine.

- 6 Repeat this procedure beginning with step 3 for the other lift cylinder.

- 7 Remove the fastener securing the fork level cylinder rod-end pivot pin to the fork frame mount.
- 8 Use a soft metal drift to remove the rod-end pivot pin.
- 9 Attach a lifting strap from an overhead crane to the barrel end of the fork level cylinder. Support the cylinder. Do not apply any lifting pressure.
- 10 Tag, disconnect and plug the fork level cylinder hoses from the cylinder manifolds. Cap the fittings.

▲ WARNING Bodily injury hazard. Spraying hydraulic oil can penetrate and burn skin. Loosen hydraulic connections very slowly to allow the oil pressure to dissipate gradually. Do not allow oil to squirt or spray.

NOTICE Component damage hazard. Hoses can be damaged if they are kinked or pinched.

- 11 Remove the fasteners securing the fork level cylinder barrel-end pivot pin to the boom.
- 12 Use a soft metal drift to remove the pivot pin. Remove the cylinder from the boom.

▲ WARNING Crushing hazard. The cylinder could fall if not properly supported when the pivot pin is removed from the machine.

- 13 Remove the inspection cover at the pivot end of the boom.
- 14 Remove the hose keepers from the hose roller assembly.

Note: The hose keepers ensure that the hoses do not jump off the hose rollers.

Boom Components

- 15 Working at the pivot end of the boom, remove the clamps securing the hoses to the inside of boom tube number 3.
 - 16 Working at the fork end of the boom, remove the clamps securing the hoses to the inside of boom tube number 3.
 - 17 Working at the pivot end of the boom, pull the fork level hydraulic hoses from the boom and lay them to the side.
 - 18 Working at the pivot end of the boom, remove the fasteners securing the hose roller assembly to boom tube number 2. Remove the hose roller assembly from the boom.
 - 19 Working at the fork end of the boom, loosen evenly, then remove, the fasteners securing the chain tensioners to the top of boom tube number 1.
 - 20 Working at the fork end of the boom, remove the fasteners securing the extension chain rollers to the top of boom tube number 2. Remove the chain rollers from the boom.
 - 21 Working at the pivot end of the boom, remove the fasteners securing the retraction chain block pivot pin to boom tube number 3. Remove the pivot pin. Remove the chain from the roller.
 - 22 Working at the pivot end of the boom, remove the fasteners securing the retraction chain roller to boom tube number 2. Remove the chain roller from the boom.
 - 23 Working at the fork end of the boom, remove the wear pads from boom tube number 2.
 - 24 Support and slide boom tube number 3 out of boom tube number 2. Place boom tube number 3 on a structure capable of supporting it.
- ▲ WARNING** Crushing hazard. Boom tube number 3 could become unbalanced and fall when removed from the boom tube number 2 if not properly supported and attached to the overhead crane.
- Note: During removal, the overhead crane strap will need to be adjusted for proper balancing.
 - 25 Working at the fork end of the boom, remove the wear pads from boom tube number 1.
 - 26 Support and slide boom tube number 2 out of boom tube number 1. Place boom tube number 2 on a structure capable of supporting it.

▲ WARNING Crushing hazard. Boom tube number 2 could become unbalanced and fall when removed from the boom tube number 1 if not properly supported and attached to the overhead crane.

Note: During removal, the overhead crane strap will need to be adjusted for proper balancing.

Boom Components

1-3 Boom Lift Cylinder

How to Remove the Lift Cylinder

Note: When removing a hose assembly or fitting, the O-ring (if equipped) on the fitting and/or hose end must be replaced. All connections must be torqued to specification during installation. Refer to Specifications, *Hydraulic Hose and Fitting Torque Specifications*.

- 1 Attach a lifting strap from an overhead 10 ton / 10,000 kg crane to the fork end of the boom. Support the boom. Do not apply any lifting pressure.
- 2 Tag, disconnect and plug the hydraulic hoses at the lift cylinder manifold. Cap the fittings.

▲ WARNING Bodily injury hazard. Spraying hydraulic oil can penetrate and burn skin. Loosen hydraulic connections very slowly to allow the oil pressure to dissipate gradually. Do not allow oil to squirt or spray.

NOTICE Component damage hazard. Hoses can be damaged if they are kinked or pinched.

- 3 Attach a lifting strap from an overhead crane to the rod end of the lift cylinder. Support the cylinder. Do not apply any lifting pressure.
- 4 Remove the fasteners securing the lift cylinder barrel-end pivot pin to the chassis.

- 5 Use a soft metal drift to remove the pivot pin.
- 6 Remove the fasteners securing the lift cylinder rod-end pivot pin to the boom.
- 7 Use a soft metal drift to remove the pivot pin.

▲ DANGER Crushing hazard. The boom will fall if not properly supported when the pivot pin is removed from the machine.

- 8 Using the overhead crane, raise the boom to a horizontal position. Remove the cylinder from the machine.

▲ DANGER Crushing hazard. The cylinder will fall if not properly supported when removed from the machine.

Boom Components

1-4 Boom Extension Cylinder

How to Remove the Extension Cylinder

Note: When removing a hose assembly or fitting, the O-ring (if equipped) on the fitting and/or hose end must be replaced. All connections must be torqued to specification during installation. Refer to Specifications, *Hydraulic Hose and Fitting Torque Specifications*.

- 1 Raise the boom to a horizontal position.
- 2 Tag, disconnect and plug the hydraulic hoses at the boom extension cylinder manifold. Cap the fittings.

⚠ WARNING Bodily injury hazard. Spraying hydraulic oil can penetrate and burn skin. Loosen hydraulic connections very slowly to allow the oil pressure to dissipate gradually. Do not allow oil to squirt or spray.

NOTICE Component damage hazard. Hoses can be damaged if they are kinked or pinched.

- 3 Remove the access covers on the number 1 boom and remove the bolts holding the extend cylinder support at the fork end of the machine.
- 4 At the pivot end of the machine, remove the retainer plates securing the extension cylinder to the number 2 and number 3 tubes and lift the extension cylinder out of the support sockets.
- 5 Support the extension cylinder with a suitable lifting device and remove from the boom assembly.

Note: During removal, the overhead crane strap will need to be adjusted for proper balancing.

1-5 Fork Level Cylinder

How to Remove the Fork Level Cylinder

Note: When removing a hose assembly or fitting, the O-ring (if equipped) on the fitting and/or hose end must be replaced. All connections must be torqued to specification during installation. Refer to Specifications, *Hydraulic Hose and Fitting Torque Specifications*.

- 1 Remove the lifting fork frame. Refer to Repair Procedure, *How to Remove the Lifting Fork Frame*.
- 2 Remove the fastener securing the fork level cylinder rod-end pivot pin to the fork frame mount.
- 3 Use a soft metal drift to remove the pivot pin.
- 4 Attach a lifting strap from an overhead crane to the barrel end of the fork level cylinder. Support the cylinder. Do not apply any lifting pressure.

Boom Components

- 5 Tag, disconnect and plug the fork level cylinder hoses from the cylinder manifolds. Cap the fittings.

▲ WARNING Bodily injury hazard. Spraying hydraulic oil can penetrate and burn skin. Loosen hydraulic connections very slowly to allow the oil pressure to dissipate gradually. Do not allow oil to squirt or spray.

NOTICE Component damage hazard. Hoses can be damaged if they are kinked or pinched.

- 6 Remove the fasteners securing the fork level cylinder barrel-end pivot pin to the boom.
- 7 Use a soft metal drift to remove the pivot pin. Remove the cylinder from the machine.

▲ WARNING Crushing hazard. The cylinder could fall if not properly supported when the pivot pin is removed from the machine.

1-6 Hydraulic Hoses

How to Adjust the Fork Level Cylinder and/or Auxiliary Hose

- 1 Fully retract the boom.
- 2 Fully lower the tips of the lifting forks.
- 3 Remove the cover from the fork end of the boom.
- 4 Loosen the hose clamp securing the fork level cylinder or auxiliary hoses.
- 5 Pull each hose until it is equally tensioned and not touching the boom tube.
- 6 Tighten the clamp bolt to secure the hoses in place.

Boom Components

How to Replace the Fork Level Cylinder and/or Auxiliary Hoses

Note: When removing a hose assembly or fitting, the O-ring (if equipped) on the fitting and/or hose end must be replaced. All connections must be torqued to specification during installation. Refer to Specifications, *Hydraulic Hose and Fitting Torque Specifications*.

- 1 Fully retract the boom.
- 2 Fully lower the tips of the lifting forks.
- 3 Remove the cover from the fork end of the boom.
- 4 Attach a lifting strap from an overhead crane to the top of the lifting fork frame. Support the frame. Do not apply any lifting pressure.
- 5 Disconnect and plug the fork level cylinder supply hoses at the cylinder manifold or the auxiliary supply hoses at the quick connect fittings. Cap the fittings.

▲ WARNING Bodily injury hazard. Spraying hydraulic oil can penetrate and burn skin. Loosen hydraulic connections very slowly to allow the oil pressure to dissipate gradually. Do not allow oil to squirt or spray.

NOTICE Component damage hazard. Hoses can be damaged if they are kinked or pinched.

- 6 Working near the center of the boom assembly, tag, disconnect and plug the hydraulic hoses from the hydraulic hard lines under boom tube number number 1. Cap the hard lines.

- 7 Securely connect a 30 feet / 10 m length of rope to each end of the hoses disconnected in steps 5 and 6. Securely tie off the other end of each section of rope to the boom structure.
- 8 Remove the hose clamp at the fork end of the boom by loosening the hose clamp bolt located on the top of the boom.
- 9 Remove the cover from the pivot end of the boom and remove the hose sheave cover.

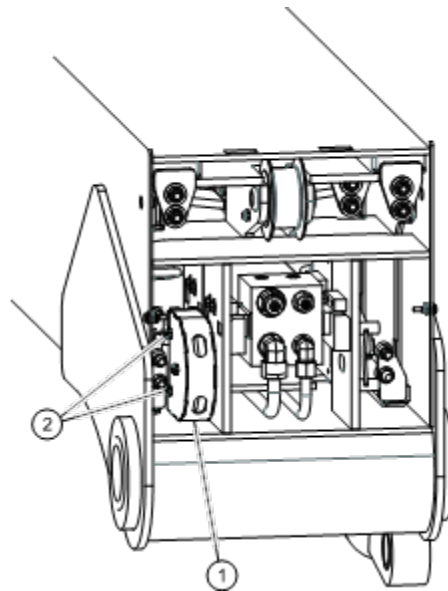

- 1 hose sheave cover
- 2 cover retaining bolts

Note: Partial extension of the boom on some machines may be necessary to access the sheave cover fasteners.

Boom Components

- 10 Select one of the hoses. Pull the hose out of the boom.

Note: Rope coming loose from either end of the hose or the boom during hose removal may result in a difficult reassembly. Be sure each section of rope is securely attached to both the hose and the boom structure before pulling the hose out of the boom.

- 11 Remove the rope from each end of the hose. Discard the hose.
- 12 Securely install a section of rope onto each end of the new hose assembly.

Note: Tag each hose before assembly.

- 13 Install the new hose assembly into the boom in the same manner the hose was removed. Using the rope, carefully pull the hose through the boom until each end is accessible.
- 14 Install both ends of the hose assembly onto the correct connection points. Torque to specification. Refer to Section 2, Specifications.
- 15 Repeat this procedure for the remaining hose to be replaced, beginning with step 8.
- 16 Tension the hoses using the Repair procedure, "How to Adjust the Fork Level and Auxiliary Hydraulic Hoses".
- 17 Repeat this procedure for the auxiliary hydraulic hoses beginning with step 5.
- 18 Remove the lifting strap from the fork frame.
- 19 Install hose sheave covers removed in step 9.
- 20 Install the covers onto both ends of the boom. Install and securely tighten the retaining fasteners.

Operator's Compartment

2-1

Operator's Compartment

How to Remove the Operator's Compartment

The operator's compartment is used to activate machine functions while sitting in the operator's drivers seat.

Within the operator's compartment there is a transmission column shifter, steering selector, 4-way controller, accelerator pedal, brake pedal and a differential lock switch. All of these components are replaceable.

For further information or assistance, consult Genie Product Support.

▲ WARNING Bodily injury hazard. This procedure requires specific repair skills, lifting equipment and a suitable workshop. Attempting this procedure without these skills and tools could result in death or serious injury and significant component damage. Dealer service is strongly recommended.

- 1 Disconnect the battery from the machine.

▲ WARNING Electrocutation/burn hazard. Contact with electrically charged circuits could result in death or serious injury. Remove all rings, watches and other jewelry.

- 2 Locate the secondary function manifold under the manifold inspection cover. Tag, disconnect and plug the hydraulic hoses at ports BP and BT of the secondary function manifold. Cap the fittings.

- 3 Locate the brake manifold under the manifold inspection cover. Tag, disconnect and plug the hydraulic hose at the underside of the brake manifold. Cap the fitting.
- 4 Working under the dashboard, locate the hydraulic hose at port L of the steering orbital.
- 5 Working at the front axle, locate the hydraulic hose connected to the front axle steer cylinder at the operator's compartment side of the machine. Tag, disconnect and plug the hydraulic hose. Cap the fitting.
- 6 Tag, disconnect and plug the hydraulic hoses at ports SUP, SUR and SUT of the secondary function manifold. Cap the fitting.

▲ WARNING Bodily injury hazard. Spraying hydraulic oil can penetrate and burn skin. Loosen hydraulic connections very slowly to allow the oil pressure to dissipate gradually. Do not allow oil to squirt or spray.

- 7 Remove the fasteners securing the joystick mount to the operator's compartment. Disconnect the joystick harness and the remove the joystick assembly.
- 8 Working inside the chassis, tag and disconnect the wire harnesses at the connectors next to the operator's compartment.

Operator's Compartment

- 9 Support and secure the operator's compartment to an adjustable table capable of supporting the weight and that will allow the operator's compartment to remain in an upright and stable position.

NOTICE Component damage hazard. Wrapping a strap around the cab and lifting using an overhead crane can put excessive pressure on the glass windows of the cab, causing the windows to break. Do not lift the cab using a strap from an overhead crane if the strap contacts the windows.

Note: Placing a wedge between the operator's compartment and the adjustable table may be required to keep the operator's compartment stable.

- 10 Remove the lower fasteners securing the operator's compartment to the chassis.
- 11 Remove the upper fasteners securing the operator's compartment to the chassis.

▲ WARNING Crushing hazard. The operator's compartment will fall if not properly supported when the fasteners are removed from the machine.

- 12 Slowly move the operator's compartment away from the chassis while feeding all loose hoses, cables and wires through the opening of the chassis.

NOTICE Component damage hazard. Hoses, cables and wires can be damaged if they are kinked or pinched.

Bolt torque specification

Operator's cab mounting bolts	750 ft-lbs 1017 Nm
-------------------------------	-----------------------

2-2 Machine Controls

How to Remove the Steering Column

- 1 Disconnect the battery from the machine.

▲ WARNING Electrocutation/burn hazard. Contact with electrically charged circuits could result in death or serious injury. Remove all rings, watches and other jewelry.

- 2 Remove the fasteners securing the transmission control lever and turn signal shifter, if equipped, to the column. Carefully separate the lever from the column.
- 3 Remove the nut securing the key switch to the dash panel. Gently push the key switch through the opening.
- 4 Remove the fasteners securing the dash panel to the dashboard.
- 5 Carefully pull the dash panel towards the seat of the operator's compartment.
- 6 Tag and disconnect the wire harness from the components of the dash panel. Remove the dash panel from the machine.
- 7 Loosen the two lower fasteners securing the dash frame to the operator's compartment.
- 8 Remove the two upper fasteners securing the dash frame to the operator's compartment.
- 9 Rotate the dash frame towards the seat of the operator's compartment. Remove the dashboard from the machine.
- 10 Tag and disconnect the ground wire of the steer column.
- 11 Support and secure the steer orbital to the dash frame.
- 12 Remove the fasteners securing the steer column and steer orbital to the dash frame.
- 13 Lower the steer orbital and remove the steer column from the machine.

Operator's Compartment

How to Remove the Steering Wheel

- 1 Open the access door above the hydraulic tank.
- 2 Disconnect the battery from the machine.

▲ WARNING Electrocutation/burn hazard. Contact with electrically charged circuits could result in death or serious injury. Remove all rings, watches and other jewelry.

- 3 Remove the horn button from the steering wheel. Remove the nut securing the steering wheel to the column and remove the steering wheel.

How to Remove the Steer Orbital

- 1 Remove the steering column. Refer to Repair Procedure, *How to Remove the Steering Column*.
- 2 Working under the dashboard, locate the hydraulic hose at port L of the steering orbital.

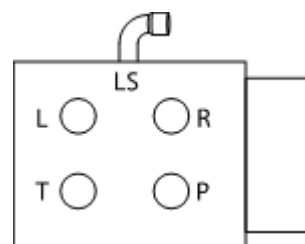

- 3 Follow the hydraulic hose from port L of the steer orbital to its connection at the front axle of the machine. Tag, disconnect and plug the hydraulic hose at the front axle. Cap the fitting.
- 4 Tag, disconnect and plug the hydraulic hoses at ports SUP, SUR and SUT of the secondary function manifold. Cap the fitting.

▲ WARNING Bodily injury hazard. Spraying hydraulic oil can penetrate and burn skin. Loosen hydraulic connections very slowly to allow the oil pressure to dissipate gradually. Do not allow oil to squirt or spray.

- 5 Tag, disconnect and plug the hydraulic hose at port SULS of the primary function manifold. Cap the fitting.
- 6 Slowly move the steer orbital away from the dash frame while feeding all loose hoses through the opening of the chassis.

Operator's Compartment

How to Remove the Joystick - Models with Electronic Joystick

- 1 Disconnect the battery from the machine.

▲ WARNING Electrocutation/burn hazard. Contact with electrically charged circuits could result in death or serious injury. Remove all rings, watches and other jewelry.

- 2 Remove the side access panel.
- 3 Tag and disconnect the joystick wire harness from the machine.
- 4 Remove the fasteners securing the joystick mount panel to the side console.
- 5 Remove the fasteners securing the joystick to the mount panel. Remove the joystick.

How to Remove the Brake Pedal Assembly

- 1 Disconnect the battery from the machine.

▲ WARNING Electrocutation/burn hazard. Contact with electrically charged circuits could result in death or serious injury. Remove all rings, watches and other jewelry.

- 2 Fully press and release the brake pedal a minimum of 10 times to release the hydraulic pressure in the brake system.
- 3 Tag, disconnect and plug the hydraulic hoses at ports BP and BT of the secondary hydraulic manifold. Cap the fittings.

▲ WARNING Bodily injury hazard. Spraying hydraulic oil can penetrate and burn skin. Loosen hydraulic connections very slowly to allow the oil pressure to dissipate gradually. Do not allow oil to squirt or spray.

- 4 Follow the hydraulic hose from port A of the brake pedal manifold to the brake manifold. Tag, disconnect and plug this hydraulic hose at the brake manifold. Cap the fitting.
- 5 Remove the fasteners securing the brake pedal assembly to the dash frame.
- 6 Gently rotate the brake pedal in an upwards direction and slowly move the brake pedal assembly away from the dash frame while feeding all loose hoses through the opening of the chassis.

Operator's Compartment

How to Remove the Gauge Cluster Assembly

- 1 Disconnect the battery from the machine.

⚠ WARNING Electrocution/burn hazard. Contact with electrically charged circuits could result in death or serious injury. Remove all rings, watches and other jewelry.

- 2 Remove the fasteners securing the transmission control lever to the column. Carefully separate the lever from the column.
- 3 Grasp the edge of the dash cluster and pull the cluster through the opening in the dashboard.
- 4 Tag and disconnect the wire harness from the dash cluster. Remove the dash cluster from the machine.

Fuel and Hydraulic Tanks

3-1 Fuel and Hydraulic Tanks

How to Remove the Fuel and Hydraulic Tank Assembly

▲ DANGER Explosion and fire hazard. Engine fuels are combustible. Remove the fuel tank in an open, well-ventilated area away from heaters, sparks, flames and lighted tobacco. Always have an approved fire extinguisher within easy reach.

▲ DANGER Explosion and fire hazard. Never drain or store fuel in an open container due to the possibility of fire.

▲ DANGER Explosion and fire hazard. When transferring fuel, connect a grounding wire between the machine and pump or container.

- 1 Open the access door to the engine.
- 2 Disconnect the battery from the machine.

▲ WARNING Electrocutation/burn hazard. Contact with electrically charged circuits could result in death or serious injury. Remove all rings, watches and other jewelry.

HYDRAULIC TANK

- 3 Remove the access cover to the hydraulic tank.
- 4 Remove the filler cap from the hydraulic tank.
- 5 Place a drain pan or other suitable container under the hydraulic tank. Refer to Specifications, *Machine Specifications*.
- 6 Remove the drain plug from the hydraulic tank and completely drain the tank.

▲ CAUTION Bodily injury hazard. Beware of hot oil. Contact with hot oil may cause severe burns.

- 7 Tag, disconnect and plug the supply and return hoses from the hydraulic tank. Cap the fittings.
- 8 Proceed to step 14.

Fuel and Hydraulic Tanks

FUEL TANK

- 9 Remove the access cover above the fuel tank and the access door above the filler cap.
- 10 Tag and disconnect the wire harness from the fuel level terminals.
- 11 Remove the filler cap from the fuel tank.
- 12 Using an approved hand-operated pump, drain the fuel tank into a container of suitable capacity. Refer to Specifications, *Machine Specifications*.

⚠ DANGER Explosion and fire hazard. When transferring fuel, connect a grounding wire between the machine and pump or container.

Note: Be sure to only use a hand operated pump suitable for use with gasoline and/or diesel fuel.

- 13 Tag, disconnect and plug the fuel supply and return hoses. Cap the fittings.
- 14 Support and secure the tank assembly to an appropriate lifting device.
- 15 Remove the fasteners securing the tank assembly to the chassis. Remove the tank from the machine.

⚠ WARNING Crushing hazard. The tank assembly could become unbalanced and fall if not properly supported when removed from the machine.

Engines

4-1 Engines

How to Repair the Perkins 1104D-E44TA Engine

Repair procedures and additional engine information is available in the Perkins 1100 Operation and Maintenance Manual and the Perkins 1104 Service Manual and the Perkins 1100 Troubleshooting Manual.

Perkins 1100 Operation and Maintenance Manual	
Genie part number	123702
Perkins 1104 Service Manual	
Genie part number	117764
Perkins 1100 Troubleshooting Manual	
Genie part number	123583

How to Repair the Perkins 854E-34TA Engine

Repair procedures and additional engine information is available in the Perkins 854 Systems Operation Testing & Adjusting or the Perkins 854 Disassembly & Assembly.

Perkins 854 Operation Manual	
Genie part number	218711
Perkins 854 Assembly Manual	
Genie part number	218712

How to Repair the Deutz TCD3.6 Engine

Maintenance procedures and additional engine information is available in the Deutz TCD3.6 Workshop Manual.

Deutz TCD3.6 T3/T4i Workshop Manual	
Genie part number	218704
Deutz TCD3.6 T4F Workshop Manual	
Genie part number	1270993

Engines

4-2 Engine Fault Codes

How to Retrieve Engine Fault Codes

When the engine Electronic Control Module (ECM) detects an abnormal operating condition, a fault code is immediately stored in the ECM memory. At the same time, a colored warning lamp is illuminated.

To view the fault code, push and hold the diagnostic button for 5 seconds. The fault code will be displayed on the screen, if present. If more than one code is present, quickly push the diagnostic button to cycle through the codes. Push and hold the diagnostic button for 5 seconds to return to the operation screen.

To learn the specifics of and how to use the fault codes, refer to, Fault Codes Section.

Transmission

5-1 Transmission

How to Repair the Transmission

Repair procedures and additional transmission information is available in the Dana VDT12000 Service Manual.

Dana VDT12000 Service Manual

Genie part number	218706
-------------------	--------

Hydraulic Pump

6-1 Hydraulic Pump

How to Test the Function Pump

Note: When removing a hose assembly or fitting, the O-ring (if equipped) on the fitting and/or hose end must be replaced. All connections must be torqued to specification during installation. Refer to Specifications, *Hydraulic Hose and Fitting Torque Specifications*.

▲ WARNING Bodily injury hazard. Spraying hydraulic oil can penetrate and burn skin. Loosen hydraulic connections very slowly to allow the oil pressure to dissipate gradually. Do not allow oil to squirt or spray.

- 1 Connect a 0 to 5000 psi / 0 to 350 bar pressure gauge to port TP on the secondary function manifold.

- 2 Start the engine and fully retract the boom. Continue to hold the joystick in the boom retract position and observe the pressure gauge.
 - ⊙ Result: If the pressure gauge reads 3200 psi / 220 bar, immediately stop. The pump is good.
 - ⊗ Result: If the pressure fails to reach 3200 psi / 220 bar, the pump needs to be adjusted OR or the pump or pump coupling is faulty and will need to be serviced or replaced.

NOTICE

Component damage hazard. There is no relief valve in the hydraulic pump and the pump can be damaged if the pressure is allowed to exceed specification. When testing the pump, crank the engine in one second intervals until the correct pressure is confirmed. Do not over-pressurize the pump.

- 3 Remove the pressure gauge and install plug onto port TP. Torque to specification. Refer to Section Specifications, *Hydraulic Specifications*.

▲ WARNING Bodily injury hazard. Spraying hydraulic oil can penetrate and burn skin. Loosen hydraulic connections very slowly to allow the oil pressure to dissipate gradually. Do not allow oil to squirt or spray.

Hydraulic Pump

How to Remove the Function Pump

▲ WARNING Bodily injury hazard. This procedure requires specific repair skills, lifting equipment and a suitable workshop. Attempting this procedure without these skills and tools could result in death or serious injury and significant component damage. Dealer service is strongly recommended.

Note: When removing a hose assembly or fitting, the O-ring (if equipped) on the fitting and/or hose end must be replaced. All connections must be torqued to specification during installation. Refer to Specifications, *Hydraulic Hose and Fitting Torque Specifications*.

Note: Perform this procedure with the engine off and cool.

- 1 Open the engine cover.
- 2 Disconnect the battery from the machine.

▲ WARNING Electrocution/burn hazard. Contact with electrically charged circuits could result in death or serious injury. Remove all rings, watches and other jewelry.

- 3 Tag and disconnect the case drain hose at the top of the pump. Cap the fitting on the pump.

Note: Placing the open end of the case drain hose below the hydraulic oil level in the hydraulic tank will result in excessive hydraulic fluid leaking from the hose. Do not lower the open end of the case drain hose to below the fluid level of the hydraulic tank until the hose is plugged.

- 4 Tag, disconnect and plug the large hydraulic pump supply hose at the pump. Cap the fitting on the pump.

Note: Placing the open end of the pump supply hose below the fluid level in the hydraulic tank will result in excessive hydraulic fluid leaking from the hose. Do not lower the open end of the pump supply hose to below the fluid level of the hydraulic tank until the hose is plugged.

- 5 Tag, disconnect and plug the high pressure hose at the pump. Cap the fitting on the pump.

▲ WARNING Bodily injury hazard. Spraying hydraulic oil can penetrate and burn skin. Loosen hydraulic connections very slowly to allow the oil pressure to dissipate gradually. Do not allow oil to squirt or spray.

- 6 Remove the fasteners securing the pump to the transmission. Remove the pump from the machine.

Hydraulic Pump

How to Install the Function Pump

- 1 Carefully install the hydraulic pump onto the transmission. Install the fasteners and tighten to finger tight.
- 2 Torque the fasteners evenly to 85 ft-lbs / 115 Nm.
- 3 Install the smaller high pressure hose onto the pump outlet. Torque the fasteners to 27-37 ft-lbs / 37-50 Nm.
- 4 Install the larger low pressure hose onto the pump outlet. Install the hose retaining rings and fasteners. Torque the fasteners to 55-66 ft-lbs / 74-90 Nm.
- 5 Working at the case drain at the top of the pump, fill the pump with hydraulic fluid until the fluid is at the top of the case drain fitting.
- 6 Install the case drain hose onto the pump and torque to specification. Refer to Specifications, *Hydraulic Specifications*.
- 7 Securely install the wire harness onto the pump.
- 8 Check the level of the hydraulic fluid in the hydraulic tank. Add fluid if needed.
- 9 Prime the pump. Refer to Repair Procedure, *How to Prime the Function Pump*.
- 10 Start the engine and inspect for leaks.
- 11 Turn the machine off.
- 12 Adjust the pump pressure. Refer to Repair Procedures, *How to Adjust the Function Pump Standby Pressure* and *How to Adjust the Function Pump Pressure Pressure Compensator*.

How to Prime the Function Pump

Note: When removing a hose assembly or fitting, the O-ring (if equipped) on the fitting and/or hose end must be replaced. All connections must be torqued to specification during installation. Refer to Specifications, *Hydraulic Hose and Fitting Torque Specifications*.

- 1 Install all hoses onto the hydraulic pump. Torque to specification. Refer to Specifications, *Hydraulic Hose and Fitting Torque Specifications*.
- 2 Locate the case drain filler plug at the side of the function pump.
- 3 Remove the plug and slowly fill the case drain port of the pump with hydraulic fluid until the oil level is even with the bottom of the hole. Install the plug and torque to 40 ft-lbs / 54 Nm.
- 4 Start the engine, allow the engine to run at low idle for 15 seconds then shut off the engine. Wait 15 seconds, then start the engine again. Allow the engine to run at low idle for 15 seconds and then shut off the engine.
- 5 Check for hydraulic leaks and clean up any oil that may have spilled.

Hydraulic Pump

How to Adjust the Function Pump Standby Pressure

- 1 Connect a 0 to 1000 psi / 0 to 100 bar pressure gauge to test port 'TP' on the primary function manifold. See 7-1 or 7-2, Primary Function Manifold Components.
- 2 Start the engine and allow the engine to run at low idle.
- 3 Observe the pressure reading on the pressure gauge.
 - ⊙ Result: The pressure gauge reads 450 ±25 psi / 31 ±1.7 bar. The pump is functioning correctly. Proceed to step 6.
 - ⊗ Result: The pressure gauge fails to read 450 ±25 psi / 31 ±1.7 bar. The pressure setting needs to be adjusted. Proceed to step 4.
- 4 Loosen the set screw for the standby pressure adjustment screw.

- 5 Adjust the function pump standby pressure. Turn the adjustment screw clockwise to increase the pressure or counterclockwise to decrease the pressure. Tighten the set screw.

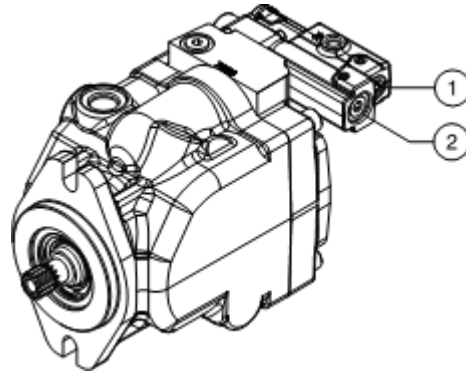

- 1 Standby Pressure Adjustment
- 2 Pressure compensator adjustment

- 6 Turn the engine off and remove the pressure gauge.

▲ WARNING

Bodily injury hazard. Spraying hydraulic oil can penetrate and burn skin. Loosen hydraulic connections very slowly to allow the oil pressure to dissipate gradually. Do not allow oil to squirt or spray.

Hydraulic Pump

How to Adjust the Function Pump Standby Pressure

Note: Two people will be required to perform this procedure.

- 1 Connect a 0 to 5000 psi / 0 to 350 bar pressure gauge to port 'M1' on the function pump.
 - 2 Start the engine and allow the engine to run at low idle.
 - 3 Fully retract the boom.
 - 4 Continue to activate the boom retract function and observe the pressure reading on the pressure gauge.
- ⊙ Result: The pressure gauge reads 3200 ± 150 psi / 220 ± 10.3 bar. The pump is functioning correctly. Proceed to step 7.
 - ⊗ Result: The pressure gauge fails to read 3200 ± 150 psi / 220 ± 10.3 bar. The pressure setting needs to be adjusted. Proceed to step 5.

- 5 Loosen the set screw for the pressure compensator adjustment screw.

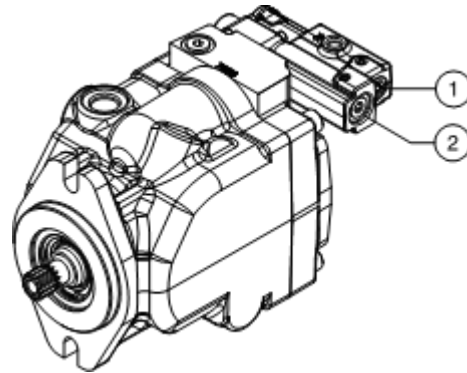

- 1 Standby pressure adjustment
- 2 Pressure compensator adjustment

- 6 Adjust the pressure compensator pressure. Turn the adjustment screw clockwise to increase the pressure or counterclockwise to decrease the pressure. Tighten the set screw.

NOTICE

Component damage hazard. Do not adjust the pressure compensator higher than specified.

- 7 Turn the engine off and remove the pressure gauge.

WARNING

Bodily injury hazard. Spraying hydraulic oil can penetrate and burn skin. Loosen hydraulic connections very slowly to allow the oil pressure to dissipate gradually. Do not allow oil to squirt or spray.

Manifolds

7-1 PVG Manifold Components

The Proportional Valve Group manifold is located at the rear of the chassis.

Index No.	Description	Function
1	Assembly, auxiliary	Auxiliary functions
2	Assembly, extend/retract	Extend/retract functions
3	Assembly, tilt	Tilt functions
4	Assembly, sway	Sway functions
5	Assembly, lift	Lift functions

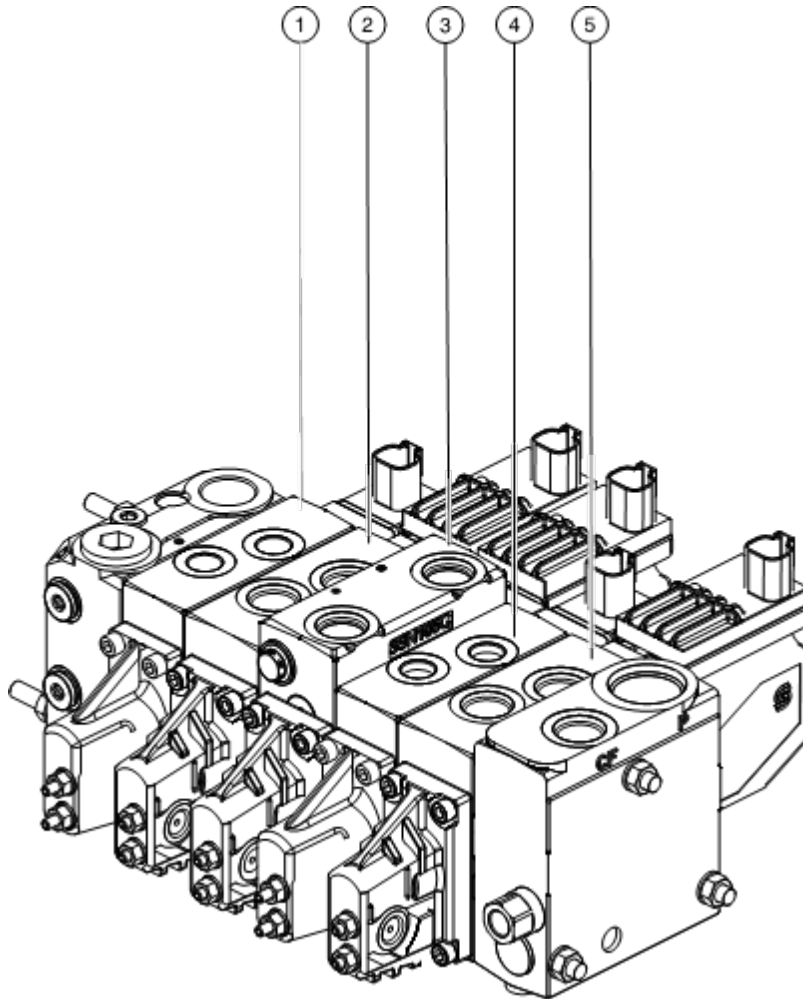

Manifolds

7-2

Secondary Function Manifold Components

The secondary function manifold is located under the manifold inspection cover.

Index No.	Description	Schematic Item	Function	Torque
1	DO3 valve, 3 position 4 way	SVD1	Steer left/right	60 in-lbs / 6.8 Nm
2	Pressure reducing/relief valve, 50 psi / 3.4 bar	PR2	Rear lock-up circuit	50 ft-lbs / 68 Nm
3	Pressure reducing/relief valve, 250 psi / 17.2 bar	PR1	Differential lock-up circuit	25-30 ft-lbs / 34-41 Nm
4	Pressure reducing/relief valve, 350 psi / 24.8 bar	PR4	Parking brake circuit	25-30 ft-lbs / 34-41 Nm
5	Solenoid valve, 2 position 3 way	SV5	Parking brake release	20 ft-lbs / 27 Nm
6	Check valve, 5 psi / 0.35 bar	CV9	Brake circuit	20 ft-lbs / 27 Nm
7	Solenoid valve, 2 position 3 way	SV7	Rear lock up select	19-21 ft-lbs / 25.8-28.6 Nm
8	Solenoid valve, 2 position 3 way	SV6	Differential lock up select	19-21 ft-lbs / 25.8-28.6 Nm

Manifolds

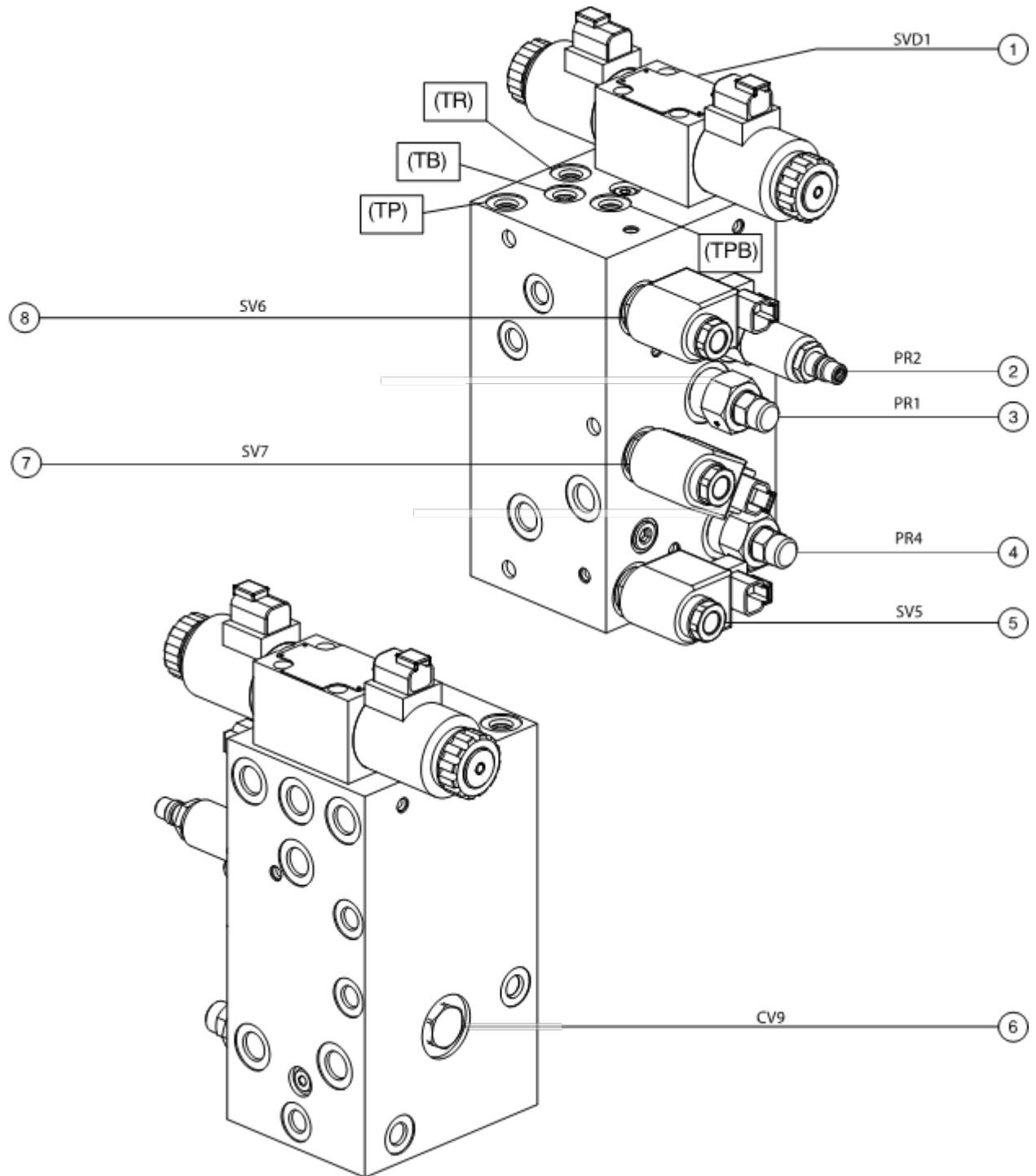

Manifolds

7-3 Brake Manifold Components

The auxiliary manifold is located under the transmission inspection cover.

Index No.	Description	Schematic Item	Function	Torque
1	Pressure switch, 450 psi / 31 bar	S6	Clutch cut-off pressure	11 ft-lbs / 14.9 Nm
2	Pressure switch, 50 psi / 3.4 bar	S16	Brake light pressure (option)	11 ft-lbs / 14.9 Nm

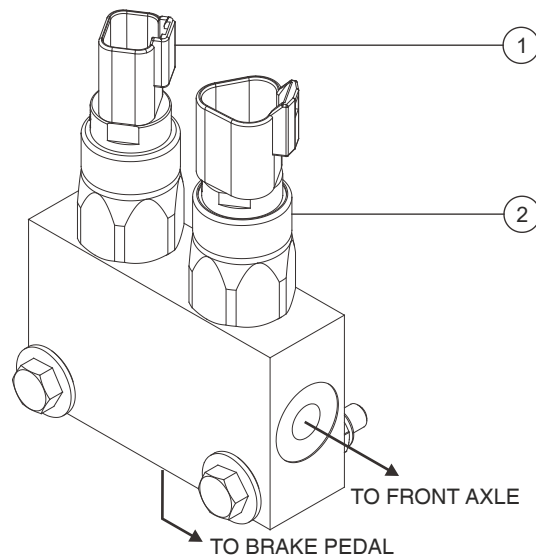

Manifolds

7-4 Valve Adjustments - Secondary Function Manifold

How to Set the Steer System Pressure

Note: Be sure that the hydraulic oil level is visible in the inspection glass of the hydraulic tank.

- 1 Install a 0 to 1000 psi / 0 to 100 bar pressure gauge into test port 'TP' at the top of the secondary function manifold, refer to Secondary Function Manifold Components.
- 2 Start the engine. Allow the engine to idle after warming the engine to operating temperature.
- 3 Without operating any machine controls, observe the reading on the pressure gauge.
 - ⦿ Result: The pressure gauge reads 650 ±20 psi / 44.8 ±1.4 bar. The pump is functioning correctly.
 - ⊗ Result: The pressure gauge fails to read 650 ±20 psi / 44.8 ±1.4 bar. The pressure setting needs to be adjusted. Refer to Repair Procedure, *How to Adjust the Function Pump Pressure*.
- 4 Turn the machine off. Remove the pressure gauge from the test port.

▲ WARNING Bodily injury hazard. Spraying hydraulic oil can penetrate and burn skin. Loosen hydraulic connections very slowly to allow the oil pressure to dissipate gradually. Do not allow oil to squirt or spray.

- 5 Install a 0 to 3500 psi / 0 to 250 bar pressure gauge into test port 'TS' at the top of the secondary function manifold. Refer to Secondary Function Manifold Components.

- 6 Start the engine. Allow the engine to idle.
- 7 Fully turn and hold the steering wheel in the left direction and allow the wheels to fully turn to the left. Continue holding the steering while observing the pressure reading on the pressure gauge.
 - ⦿ Result: The pressure gauge reads 2650 psi±50 psi / 183±3.4 bar. The pressure setting is correct. Proceed to step 12.
 - ⊗ Result: The pressure gauge fails to read 2650 psi±50 psi / 183±3.4 bar. The pressure setting needs to be adjusted. Proceed to step 8.
- 8 Turn the machine off. Hold the steer pressure reducing/relief valve with a wrench and remove the cap (schematic item PR3).
- 9 Adjust the internal hex socket. Turn it clockwise to increase the pressure or counterclockwise to decrease the pressure.

NOTICE Component damage hazard. Do not adjust the relief valve pressures higher than specifications.

- 10 Install the relief valve cap.
- 11 Repeat this procedure beginning with step 6.
- 12 Turn the machine off. Remove the pressure gauge from the test port.

▲ WARNING Bodily injury hazard. Spraying hydraulic oil can penetrate and burn skin. Loosen hydraulic connections very slowly to allow the oil pressure to dissipate gradually. Do not allow oil to squirt or spray.

Manifolds

How to Set the Parking Brake System Pressure

Note: Be sure that the hydraulic oil level is visible in the inspection glass of the hydraulic tank.

- 1 Install a 0 to 1000 psi / 0 to 100 bar pressure gauge into test port 'TP' at the top of the primary function manifold, Refer to Primary Function Manifold Components.
- 2 Start the engine. Allow the engine to idle after warming the engine to operating temperature.
- 3 Without operating any machine controls, observe the reading on the pressure gauge.
 - ⦿ Result: The pressure gauge reads 650 \pm 20 psi / 44.8 \pm 1.4 bar. The pump is functioning correctly.
 - ⊗ Result: The pressure gauge fails to read 650 \pm 20 psi / 44.8 \pm 1.4 bar. The pressure setting needs to be adjusted. Refer to Repair Procedure, *How to Adjust the Function Pump Pressure*.
- 4 Turn the machine off. Remove the pressure gauge from the test port.

⚠ WARNING Bodily injury hazard. Spraying hydraulic oil can penetrate and burn skin. Loosen hydraulic connections very slowly to allow the oil pressure to dissipate gradually. Do not allow oil to squirt or spray.

- 5 Install a 0 to 1000 psi / 0 to 100 bar pressure gauge into test port 'TPB' at the top of the secondary function manifold, Refer to Secondary Function Manifold Components.

- 6 Start the engine. Allow the engine to idle.
 - ⦿ Result: The pressure gauge reads 350 psi / 24.1. The pressure setting is correct. Proceed to step 11.
 - ⊗ Result: The pressure gauge fails to read 350 psi / 24.1. The pressure setting needs to be adjusted. Proceed to step 7.
- 7 Turn the machine off. Hold the brake pressure reducing/relief valve with a wrench and remove the cap (schematic item PR4).
- 8 Adjust the internal hex socket. Turn it clockwise to increase the pressure or counterclockwise to decrease the pressure.

NOTICE Component damage hazard. Do not adjust the relief valve pressures higher than specifications.

- 9 Install the relief valve cap.
- 10 Repeat this procedure beginning with step 6.
- 11 Turn the machine off. Remove the pressure gauge from the test port.

⚠ WARNING Bodily injury hazard. Spraying hydraulic oil can penetrate and burn skin. Loosen hydraulic connections very slowly to allow the oil pressure to dissipate gradually. Do not allow oil to squirt or spray.

Manifolds

How to Set the Rear Lock-up System Pressure

Note: Be sure that the hydraulic oil level is visible in the inspection glass of the hydraulic tank.

- 1 Install a 0 to 1000 psi / 0 to 100 bar pressure gauge into test port 'TP' at the top of the primary function manifold. Refer to Primary Function Manifold Components.
- 2 Start the engine. Allow the engine to idle after warming the engine to operating temperature.
- 3 Without operating any machine controls, observe the reading on the pressure gauge.
 - ⦿ Result: The pressure gauge reads 450 ±25 psi / 31 ±1.7 bar. The pump is functioning correctly.
 - ✗ Result: The pressure gauge fails to read 450 ±25 psi / 31 ±1.7 bar. The pressure setting needs to be adjusted. Refer to Repair Procedure, *How to Adjust the Function Pump Pressure*.
- 4 Turn the machine off. Remove the pressure gauge from the test port.

▲ WARNING Bodily injury hazard. Spraying hydraulic oil can penetrate and burn skin. Loosen hydraulic connections very slowly to allow the oil pressure to dissipate gradually. Do not allow oil to squirt or spray.

- 5 Install a 0 to 500 psi / 0 to 50 bar pressure gauge into test port 'TR' at the top of the secondary function manifold, Refer to Secondary Function Manifold Components.

- 6 Start the engine. Allow the engine to idle.
 - ⦿ Result: The pressure gauge reads 50 psi / 3.4 bar. The pressure setting is correct. Proceed to step 11.
 - ✗ Result: The pressure gauge fails to read 50 psi / 3.4 bar. The pressure setting needs to be adjusted. Proceed to step 7.
- 7 Turn the machine off. Hold the rear lockup pressure reducing/relief valve with a wrench and remove the cap (schematic item PR2).
- 8 Adjust the internal hex socket. Turn it clockwise to increase the pressure or counterclockwise to decrease the pressure.

NOTICE Component damage hazard. Do not adjust the relief valve pressures higher than specifications.

- 9 Install the relief valve cap.
- 10 Repeat this procedure beginning with step 6.
- 11 Turn the machine off. Remove the pressure gauge from the test port.

▲ WARNING Bodily injury hazard. Spraying hydraulic oil can penetrate and burn skin. Loosen hydraulic connections very slowly to allow the oil pressure to dissipate gradually. Do not allow oil to squirt or spray.

Manifolds

7-5 Valve Coils

How to Test a Coil

A properly functioning coil provides an electromotive force which operates the solenoid valve. Critical to normal operation is continuity within the coil that provides this force field.

Since coil resistance is sensitive to temperature, resistance values outside specification can produce erratic operation. When coil resistance decreases below specification, amperage increases. As resistance rises above specification, voltage increases.

While valves may operate when coil resistance is outside specification, maintaining coils within specification will help ensure proper valve function over a wide range of operating temperatures.

⚠ WARNING

Electrocution/burn hazard. Contact with electrically charged circuits could result in death or serious injury. Remove all rings, watches and other jewelry.

- 1 Tag and disconnect the wiring from the coil to be tested.
- 2 Test the coil resistance.
 - ⊕ Result: The resistance should be within specification, plus or minus 30%.
 - ⊗ Result: If the resistance is not within specification, plus or minus 30%, replace the coil.

Valve Coil Resistance Specification

Note: The following coil resistance specifications are at an ambient temperature of 68°F / 20°C. As valve coil resistance is sensitive to changes in air temperature, the coil resistance will typically increase or decrease by 4% for each 18°F / 10°C that your air temperature increases or decreases from 68°F / 20°C.

Valve Coil Resistance Specification	
Description	Specification
DO3 valve, 3 position 4 way 12V DC with diode (schematic items SVD1)	5.6Ω
Solenoid valve, 2 position 2 way 12V DC with diode (schematic items SV9)	8.8Ω
Solenoid valve, 2 position 3 way 12V DC with diode (schematic items SV5, SV7, SV6)	8.8Ω
Solenoid valve, 2 position 4 way 12V DC with diode (schematic items SV1, SV2, SV3, SV4)	8.8Ω

Manifolds

How to Test a Coil Diode

Properly functioning coil diodes protect the electrical circuit by suppressing voltage spikes. Voltage spikes naturally occur within a function circuit following the interruption of electrical current to a coil. Faulty diodes can fail to protect the electrical system, resulting in a tripped circuit breaker or component damage.

⚠ WARNING Electrocutation/burn hazard. Contact with electrically charged circuits could result in death or serious injury. Remove all rings, watches and other jewelry.

- 1 Test the coil for resistance. Refer to Repair Procedure, *How to Test a Coil*.
- 2 Connect a 10W resistor to the negative terminal of a known good 9V DC battery. Connect the other end of the resistor to a terminal on the coil.

Resistor 10Ω

Genie part number 27287

Note: The battery should read 9V DC or more when measured across the terminals.

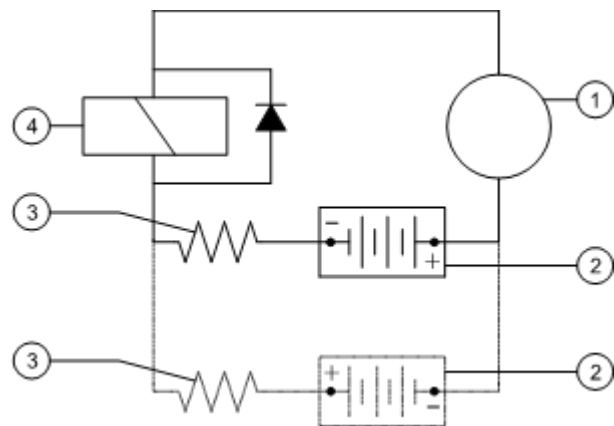

- 1 multimeter
- 2 9v DC battery
- 3 10Ω resistor
- 4 coil

Note: Dotted lines in illustration indicate a reversed connection as specified in step 6.

- 3 Set a multimeter to read DC current.

Note: The multimeter, when set to read DC current, should be capable of reading up to 800 mA.

- 4 Connect the negative lead to the other terminal on the coil.
 - 5 Momentarily connect the positive lead from the multimeter to the positive terminal on the 9V DC battery. Note and record the current reading.
 - 6 At the battery or coil terminals, reverse the connections. Note and record the current reading.
- ⊙ Result: Both current readings are greater than 0 mA and are different by a minimum of 20%. The coil is good.
 - ⊗ Result: If one or both of the current readings are 0 mA, or if the two current readings do not differ by a minimum of 20%, the coil and/or its internal diode are faulty and the coil should be replaced.

Axle

8-1 Axles

How to Remove the Axle

▲ WARNING Bodily injury hazard. This procedure requires specific repair skills, lifting equipment and a suitable workshop. Attempting this procedure without these skills and tools could result in death or serious injury and significant component damage. Dealer service is strongly recommended.

- 1 Chock the wheels.
- 2 Remove the fasteners securing the driveshaft to the transmission. Lower the end of the driveshaft to the ground.
- 3 Remove the fasteners securing the driveshaft to the axle. remove the driveshaft from the machine.
- 4 Tag and remove the hydraulic hoses from the axle.

▲ WARNING Bodily injury hazard. Spraying hydraulic oil can penetrate and burn skin. Loosen hydraulic connections very slowly to allow the oil pressure to dissipate gradually. Do not allow oil to squirt or spray.

- 5 Loosen the lug nuts of both wheels on the axle to be removed. Do not remove the lug nuts.

- 6 Raise the end of the machine until the tires are off the ground. Place blocks under the chassis for support.

▲ DANGER Crushing hazard. The chassis will fall if not properly supported.

- 7 Remove the lug nuts. Remove the tire and wheel assembly from both ends of the axle.
- 8 Support and secure the axle to an appropriate lifting device.
- 9 Remove the fasteners securing the sway cylinder rod-end pivot pin to the chassis.
- 10 Use a soft metal drift to remove the pivot pin.
- 11 Remove the fasteners securing the axle to the chassis. Remove the axle from the machine.

▲ DANGER Crushing hazard. The axle will fall if not properly supported when the fasteners are removed from the machine.

Bolt torque specification

Axle mounting bolts	380 ft-lbs 515 Nm
---------------------	----------------------

Fault Codes



Observe and Obey:

- ☑ Troubleshooting and repair procedures shall be completed by a person trained and qualified on the repair of this machine
- ☑ Immediately tag and remove from service a damaged or malfunctioning machine.
- ☑ Repair any machine damage or malfunction before operating the machine.
- ☑ Unless otherwise specified, perform each procedure with the machine in the following configuration:
 - Machine parked on a firm, level surface
 - Boom in the stowed position
 - Key switch in the off position with the key removed
 - Wheels chocked

Before Troubleshooting:

- ☑ Read, understand and obey the safety rules and operating instructions in the appropriate operator's manual on your machine.
- ☑ Be sure that all necessary tools and test equipment are available and ready for use.
- ☑ Read each appropriate fault code thoroughly. Attempting short cuts may produce hazardous conditions.
- ☑ Be aware of the following hazards and follow generally accepted safe workshop practices.

▲ WARNING

Electrocution/burn hazard. Contact with electrically charged circuits could result in death or serious injury. Remove all rings, watches and other jewelry.

Note: Two persons will be required to safely perform some troubleshooting procedures.

Diagnostic Display

When the engine Electronic Control Module (ECM) detects an abnormal operating condition, a fault code is immediately stored in the ECM memory.

The fault code is displayed on the LCD display which is located on the gauge cluster in the operator's compartment.

The gauge cluster also includes two warning lights.

They are an amber colored light which signals an abnormal engine condition which should be corrected as soon as possible and a red colored light which signals an engine condition which requires the operator to shut down the engine as soon as possible.

The ECM will, in some cases, automatically shut down the engine when the red light is displayed.

Active Fault Codes

Active Fault Codes will be displayed on the gauge cluster when the diagnostic button is pressed for 5 seconds, if present. If multiple fault codes are detected, scroll through them using the diagnostic button.

Active Codes vs Stored Codes

Active fault codes, indicating an engine condition or conditions which have not been corrected, are displayed at the moment the fault is detected.

Stored fault codes are the cumulative history of fault codes which the ECM has detected. These fault codes may be recalled by service personnel at a later time even if the condition which caused the engine fault has ceased to exist.

Note: Additional hardware will be necessary to access stored codes.

Decoding Fault Codes

The Suspect Parameter Number (SPN) and the Failure Mode Identifier (FMI), when combined, are the basis for an engine fault code. The SPN number indicates the affected component; the FMI number reveals the type of failure that has occurred. Comparing the combination of numbers to the fault code chart on the following pages will help to determine the exact engine fault and a corrective course of action. For additional information, refer to the engine operator's manual which came with your machine.

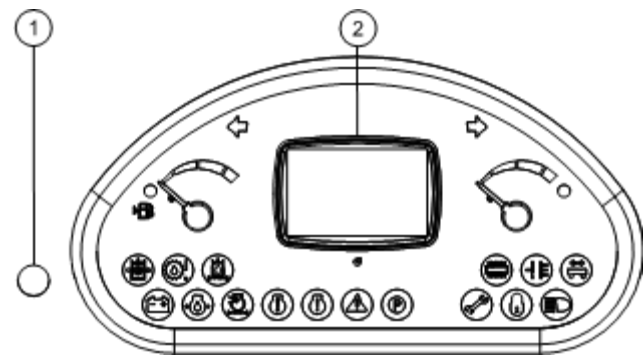

- 1 Diagnostic button
- 2 LCD screen

Deutz TCD3.6 Engine Fault Codes

SPN = Suspect Parameter Number

ASPN = Alternate Suspect Parameter Number

FMI = Failure Mode Identifier

SPN	ASPN	FMI	Description
29		3	Handthrottle; signal out of range, short circuit to battery
		4	Handthrottle; signal out of range, short circuit to ground
51		3	Actuator error EGR-Valve (2.9;3.6) or Throttle-Valve (6.1,7.8); internal error
		4	Actuator error EGR-Valve (2.9;3.6) or Throttle-Valve (6.1,7.8); internal error
		5	Actuator error EGR-Valve (2.9;3.6) or Throttle-Valve (6.1,7.8); internal error
		6	Actuator error EGR-Valve (2.9;3.6) or Throttle-Valve (6.1,7.8); internal error
		7	Actuator error EGR-Valve (2.9;3.6) or Throttle-Valve (6.1,7.8); internal error
		11	Actuator error EGR-Valve (2.9;3.6) or Throttle-Valve (6.1,7.8); internal error
84		2	Sensor vehicle speed; plausibility error
91		3	Sensor error accelerator pedal; signal range check high
		4	Sensor error accelerator pedal; signal range check low
		11	Plausibility error between APP1 and APP2 or APP1 and idle switch
94		1	Low fuel pressure; system reaction initiated
		3	Sensor error low fuel pressure; signal range check high
		4	Sensor error low fuel pressure; signal range check low
97		3	Sensor error water in fuel; signal range check high
		4	Sensor error water in fuel; signal range check low
		12	Water in fuel level prefilter; maximum value exceeded
100		0	High oil pressure; system reaction initiated
		1	High oil pressure; system reaction initiated
		3	Sensor error oil pressure; signal range check high
		4	Sensor error oil pressure sensor; signal range check low
102		2	Charged air pressure; system reaction initiated
		3	Sensor error charged air pressure; signal range check high
		4	Sensor error charged air pressure; signal range check low
105		0	Charged air cooler temperature; system reaction initiated
		3	Sensor error charged air temperature; signal range check high
		4	Sensor error charged air temperature; signal range check low

Deutz TCD3.6 Engine Fault Codes

SPN = Suspect Parameter Number

ASPN = Alternate Suspect Parameter Number

FMI = Failure Mode Identifier

SPN	ASPN	FMI	Description
107		0	Air filter differential pressure; system reaction initiated
		3	Sensor error airfilter differential pressure; short circuit to battery
		4	Sensor error airfilter differential pressure; short circuit to ground
108		3	Sensor error ambient air pressure; signal range check high
		4	Sensor error ambient air pressure; signal range check low
110		0	Coolant temperature; system reaction initiated
		3	Sensor error coolant temperature; signal range check high
		4	Sensor error coolant temperature; signal range check low
111		1	Coolant level too low
132		11	Air flow sensor; sensor error
157		3	Sensor error rail pressure; signal range check high
		4	Sensor error rail pressure; signal range check low
164		2	Rail pressure safety function is not executed correctly
168		0	Physical range check high for battery voltage
		1	Physical range check low for battery voltage
		2	High battery voltage; warning threshold exceeded
		2	Battery voltage; system reaction initiated
		3	Sensor error battery voltage; signal range check high
		3	Sensor error battery voltage; signal range check high
		4	Sensor error battery voltage; signal range check low
		4	Sensor error battery voltage; signal range check low
171		3	Sensor error environment temperature; signal range check high
		4	Sensor error environment temperature; signal range check low
172		0	Physical range check high for intake air temperature
		1	Physical range check low for intake air temperature
		2	Intake air sensor; plausibility error
		3	Sensor error intake air; signal range check high
		4	Sensor error intake air sensor; signal range check low Sensor ambient air temperature; plausibility error
174		0	High Low fuel temperature; shut off threshold exceeded High low fuel temperature; warning threshold exceeded

Deutz TCD3.6 Engine Fault Codes

SPN = Suspect Parameter Number

ASPN = Alternate Suspect Parameter Number

FMI = Failure Mode Identifier

SPN	ASPN	FMI	Description
175		0	Oil temperature; out of range, system reaction initiated
		1	Physical range check low for oil temperature
		2	Oil temperature; plausibility error
		3	Sensor error oil temperature; signal range check high
		4	Sensor error oil temperature; signal range check low
190		0	Engine speed above warning threshold (FOC-Level 1)
		2	Offset angle between crank- and camshaft sensor is too large
		8	Speed detection; out of range, signal disrupted
		11	Engine speed above warning threshold (FOC-Level 2)
		12	Speed detection; out of range, signal disrupted
411		0	Physical range check high for differential pressure Venturiunit (EGR)
		1	Physical range check low for differential pressure Venturiunit (EGR)
		3	Sensor error differential pressure Venturiunit (EGR); signal range check high
		4	Physical range check low for EGR differential pressure Sensor error differential pressure Venturiunit (EGR); signal range check low
412		3	Sensor error EGR cooler downstream temperature; signal range check high
		4	Sensor error EGR cooler downstream temperature; signal range check low
520		9	Timeout Error of CAN-Receive-Frame TSC1TR; Setpoint
597		2	Break lever mainswitch and break lever redundancyswitch status not plausible
624		3	SVS lamp; short circuit to battery
		4	SVS lamp; short circuit to ground
		5	SVS lamp; open load
		12	SVS lamp; powerstage over temperature
630		12	Access error EEPROM
639		14	CAN-Bus 0 "BusOff-Status"

Deutz TCD3.6 Engine Fault Codes

SPN = Suspect Parameter Number

ASPN = Alternate Suspect Parameter Number

FMI = Failure Mode Identifier

SPN	ASPN	FMI	Description
651		3	Injector 1 (in firing order); short circuit
		4	High side to low side short circuit in the injector 1 (in firing order)
		5	Injector 1 (in firing order); interruption of electric connection
652		3	Injector 2 (in firing order); short circuit
		4	High side to low side short circuit in the injector 2 (in firing order)
		5	Injector 2 (in firing order); interruption of electric connection
653		3	Injector 3 (in firing order); short circuit
		4	High side to low side short circuit in the injector 3 (in firing order)
		5	Injector 3 (in firing order); interruption of electric connection
654		3	Injector 4 (in firing order); short circuit
		4	High side to low side short circuit in the injector 4 (in firing order)
		5	Injector 4 (in firing order); interruption of electric connection
655		3	Injector 5 (in firing order); short circuit
		4	High side to low side short circuit in the injector 5 (in firing order)
		5	Injector 5 (in firing order); interruption of electric connection
656		3	Injector 6 (in firing order); short circuit
		4	High side to low side short circuit in the injector 6 (in firing order)
		5	Injector 6 (in firing order); interruption of electric connection
676		11	Cold start aid relay; open load, relay error.
677		3	Starter relay; short circuit
		4	Starter relay; short circuit
		5	Starter relay; no load error
		12	Starter relay; powerstage over temperature
703		3	Engine running lamp; short circuit to battery
		4	Engine running lamp; short circuit to ground
		5	Engine running lamp; open load
		12	Engine running lamp; powerstage over temperature

Deutz TCD3.6 Engine Fault Codes

SPN = Suspect Parameter Number

ASPN = Alternate Suspect Parameter Number

FMI = Failure Mode Identifier

SPN	ASPN	FMI	Description
729		5	Cold start aid relay open load
		12	Cold start aid relay; over temperature error
898		9	Timeout Error of CAN-Receive-Frame TSC1TE; Setpoint
975		3	Fan control; short circuit to battery
		4	Fan control; short circuit to ground
		5	Fan control; open load
		12	Fan control; internal error
1079		13	Sensor supply voltage monitor 1 error (ECU)
1080		13	Sensor supply voltage monitor 2 error (ECU)
1109		2	Engine shut off demand ignored
1136		0	Physikal range check high for ECU temperature
		1	Physikal range check low for ECU temperature
		3	Sensor error ECU temperature; signal range check high
		4	Sensor error ECU temperature; signal range check low
1176		3	Sensor error pressure sensor upstream turbine; signal range check high
		4	Sensor error pressure sensor downstream turbine; signal range check high
1180		0	Exhaust gas temperature turbine upstream; out of range, system reaction initiated
		1	Exhaust gas temperature turbine upstream; out of range, system reaction initiated
		3	Sensor error exhaust gas temperature upstream turbine; signal range check high
		4	Sensor error exhaust gas temperature upstream turbine; signal range check low
		11	Sensor exhaust gas temperature upstream turbine; plausibility error Exhaust gas temperature upstream turbine; out of range, system reaction initiated Exhaust gas temperature upstream turbine; out of range, system reaction initiated

Deutz TCD3.6 Engine Fault Codes

SPN = Suspect Parameter Number

ASPN = Alternate Suspect Parameter Number

FMI = Failure Mode Identifier

SPN	ASPN	FMI	Description
1188		2	Wastegate; status message from ECU missing
		7	Wastegate actuator; blocked
		11	Turbo charger wastegate actuator; internal error
		13	Wastegate actuator calibration deviation too large, recalibration required
1231		14	CAN-Bus 1 "BusOff-Status"
1235		14	CAN-Bus 2 "BusOff-Status"
1237		2	Override switch; plausibility error
1322		12	Too many recognized misfires in more than one cylinder
1323		12	Too many recognized misfires in cylinder 1 (in firing order)
		12	Too many recognized misfires in cylinder 1 (in firing order)
1324		12	Too many recognized misfires in cylinder 2 (in firing order)
1325		12	Too many recognized misfires in cylinder 3 (in firing order)
1326		12	Too many recognized misfires in cylinder 4 (in firing order)
1327		12	Too many recognized misfires in cylinder 5 (in firing order)
1328		12	Too many recognized misfires in cylinder 6 (in firing order)
1639		0	Sensor error fan speed; signal range check high
		1	Sensor error fan speed; signal range check low
1761		14	Urea tank level; warning threshold exceeded
2621		3	Flush valve burner (EPV DPF-System); short circuit to battery
		4	Flush valve burner (EPV DPF-System); short circuit to ground
		5	Flush valve burner (EPV DPF-System); open load
		12	Flush valve burner (EPV DPF-System); powerstage over temperature
2659		0	Physical range check high for EGR exhaust gas mass flow
		1	Physical range check low for EGR exhaust gas mass flow
		2	AGS sensor temperature exhaust gas mass flow; plausibility error
		12	Exhaust gas recirculation; AGS sensor has "burn off" not performed Exhaust gas recirculation AGS sensor; plausibility error

Deutz TCD3.6 Engine Fault Codes

SPN = Suspect Parameter Number

ASPN = Alternate Suspect Parameter Number

FMI = Failure Mode Identifier

SPN	ASPN	FMI	Description
2791		0	EGR actuator, temperature critical high
		2	EGR actuator, CAN error
		3	EGR actuator supply voltage is above the maximum threshold
		4	EGR actuator supply voltage is below minimum threshold
		6	EGR actuator current is above maximum threshold
		7	EGR actuator, actuator blocked or broken spring detected
		12	EGR actuator, internal electrical fault
		13	EGR actuator, EOL calibration error or learning process aborted or learning process out of range
		16	EGR actuator, temperature high
2797		4	Injector diagnostics; timeout error of short circuit to ground measurement cyl. Bank 0
2798		4	Injector diagnostics; short circuit Bank 0, Bank 1
			Injector diagnostics; timeout error of short circuit to ground measurement cyl. Bank 1
3031		0	AdBlue-Tank temperature: maximum exceeded
		1	DEF-Tank temperature: below minimum
		3	Sensor error urea tank temperature; short circuit to battery
		4	Sensor error urea tank temperature; short circuit to ground
3224		1	Nox sensor upstream of SCR Catalysator; low signal not plausible
		2	NOx Sensor; CAN DLC error
		9	NOx Sensor; CAN Timeout
3234		2	NOx Sensor; CAN DLC error
		9	NOx Sensor; CAN Timeout
		11	Nox Sensor downstream of SCR Catalysator; plausibility error "stuck in range"
3241		0	Sensor SCR catalyst upstream temperature too high; plausibility error
		1	Sensor SCR catalyst upstream temperature too low; plausibility error

Deutz TCD3.6 Engine Fault Codes

SPN = Suspect Parameter Number

ASPN = Alternate Suspect Parameter Number

FMI = Failure Mode Identifier

SPN	ASPN	FMI	Description
3248		0	Exhaust gas temperature particulate filter downstream; out of range, system reaction initiated
		1	Exhaust gas temperature particulate filter downstream; out of range, system reaction initiated
		2	Sensor exhaust gas temperature downstream DPF; plausibility error
		4	Sensor error particle filter downstream temperature; signal range check low
3251		0	Physical range check high for differential pressure (DPF); shut off regeneration
		1	Physical range check low for differential pressure (DPF); shut off regeneration
3253		2	Sensor differential pressure (DPF); plausibility error
		3	Sensor error differential pressure (DPF); signal range check high
		4	Sensor error differential pressure (DPF); signal range check low
3361		3	Urea dosing valve; short circuit to battery
		4	Urea dosing valve; short circuit to ground
		7	AdBlue dosing valve blocked (SCR)
3519		3	DEF quality sensor, internal temperature sensor short circuit to battery or open lead
		4	DEF quality sensor, internal temperature sensor short circuit to ground
		12	DEF tank temperature, temperature too high
		13	Temperature at UQS invalid
3520		3	DEF quality sensor, short circuit to battery or open load
		4	DEF quality sensor, short circuit to ground
		13	Urea quality at UQS invalid
3532		3	DEF level at UQS out of max. physical range
		3	Sensor error urea tank level; signal range check high
		4	Quality at UQS of of min. physical range
		4	Sensor error urea tank level; signal range check low
3699		2	DPF differential pressure sensor and a further sensor or actuator CRT system defective
		14	Maximum stand-still-duration reached; oil exchange required Temperature sensor us. and ds. DOC simultaneously defect
3711		12	Regeneration temperature (PFItRgn LigtOff) not reached; regeneration aborted
3936		14	Standstill request ignored too long

Deutz TCD3.6 Engine Fault Codes

SPN = Suspect Parameter Number

ASPN = Alternate Suspect Parameter Number

FMI = Failure Mode Identifier

SPN	ASPN	FMI	Description
4243		11	SCR system heater diagnostic reports error; shut off SCR-system
4334		0	Urea pump pressure; out of range
		1	Urea pump pressure; out of range
		3	Sensor error urea pump pressure; signal range check high
		4	Sensor error urea pump pressure; signal range check low
4341		3	SCR-heater urea supplyline; short circuit to battery
		4	SCR-heater urea supplyline; short circuit to ground
		5	SCR heater relay urea supplyline; open load
4343		3	SCR heater urea pressureline; short circuit to battery
		4	SCR heater urea pressureline; short circuit to ground
		5	SCR heater relay urea pressureline; open load
		11	General pressure check error (SCR)
4345		3	SCR heater urea returnline; short circuit to battery
		4	SCR heater urea returnline; short circuit to ground
		5	SCR heater relay urea returnline; open load
		11	Sensor backflow line pressure (SCR); plausibility error
4360		0	Physical range check high for urea catalyst upstream temperature
		1	Physical range low for urea catalyst upstream temperature
		3	Sensor error urea catalyst exhaust gas temperature upstream; signal range check high
		4	Sensor error urea catalyst exhaust gas temperature upstream; signal range check low
4365		0	Urea tank temperature too high
4366		3	SCR Tank heating valve; short circuit to battery
		4	SCR Tank heating valve; short circuit to ground
		5	SCR main relay (secondary side): open load
		12	SCR-heater relay urea tank powerstage output; over temperature
			SCR main relay; short circuit
			SCR Tank heating valve; open load
4374		13	Pressure stabilisation error dosing valve (SCR)

Deutz TCD3.6 Engine Fault Codes

SPN = Suspect Parameter Number

ASPN = Alternate Suspect Parameter Number

FMI = Failure Mode Identifier

SPN	ASPN	FMI	Description
4375		3	Urea pump motor; short circuit to battery
		4	Urea pump motor; short circuit to ground
		5	Urea pump motor; open load
4376		3	SCR reversing valve; short circuit to battery
		4	SCR reversing valve; short circuit to ground
		5	SCR reversing valve; open load
		12	SCR reversing valve; over temperature
4765		0	Physical range check high for exhaust gas temperature upstream (DOC)
		1	Physical range check low for exhaust gas temperature upstream (DOC)
4766		0	Physical range check high for exhaust gas temperature downstream (DOC)
		1	Physical range check low for exhaust gas temperature downstream (DOC)
4768		2	Sensor exhaust gas temperature upstream (DOC); plausibility error
		3	Sensor error exhaust gas temperature upstream (DOC); signal range check high
		4	Sensor error exhaust gas temperature upstream (DOC); signal range check low
4769		2	Sensor exhaust gas temperature (DOC) downstream; plausibility error
		3	Sensor error exhaust gas temperature downstream (DOC); signal range check high
		4	Sensor error exhaust gas temperature downstream (DOC); signal range check low
			Sensor exhaust gas temperature downstream (DOC); plausibility error
5763		0	Warning threshold for an internal actuator error exceeded, <4L EGR actuator and >4L Air Intake Flap
		1	Shutoff threshold for an internal actuator error exceeded, <4L EGR actuator and >4L Air Intake Flap
		3	Position sensor error of actuator EGR-Valve (2.9; 3.6) Signal range check high
		3	Actuator EGR-Valve (2.9; 3.6); short circuit to battery
		4	Actuator EGR-Valve (2.9; 3.6); short circuit to ground; Voltage below threshold
		5	Actuator EGR-Valve (2.9; 3.6); Open load on ECU output is detected
		6	Actuator error EGR-Valve; signal range check high
		7	Actuator position for EGR-Valve (2.9; 3.6)
		11	Power stage over temperature due to high current
20521		5	Actuator error EGR-Valve (2.9;3.6) Signal range check low

Deutz TCD3.6 Engine Fault Codes

SPN = Suspect Parameter Number

ASPN = Alternate Suspect Parameter Number

FMI = Failure Mode Identifier

SPN	ASPN	FMI	Description
23006	64254	3	Controller mode switch; short circuit to battery
		4	Controller mode switch; short circuit to ground
23008	64256	1	Manipulation control was triggered
		2	Timeout error in Manipulation control
23009	64257	9	Pressure Relief Valve (PRV) reached maximum allowed opening count
		10	Pressure relief valve (PRV) reached maximum allowed open time
23090		2	Engine Brake Pre-Selection switch; Plausibility Error
23212	64460	9	Timeout Error of CAN-Receive-Frame ComEngPrt; Engine Protection
23216	64464	9	Timeout Error of CAN-Receive-Frame PrHtEnCmd; pre-heat command, engine command
23240	64488	9	Timeout CAN-message FunModCtl; Function Mode Control
23330	64578	14	Immobilizer status; fuel blocked
23350	64598	4	Injector cylinder-bank 1; short circuit
23352	64600	4	Injector cylinder-bank 2; short circuit
23354	64602	12	Injector powerstage output defect
23450	64698	2	Multiple Stage Switch constant speed; plausibility error
		3	Multiple Stage Switch constant speed; short circuit to battery
		4	Multiple Stage Switch constant speed; short circuit to ground
23451	64699	2	Multiple Stage Switch engine speed control parameter; plausibility error
		3	Multiple Stage Switch engine speed control parameter; short circuit to battery
		4	Multiple Stage Switch engine speed control parameter; short circuit to ground
23452	64700	2	Multiple Stage Switch engine torque limitation curve; plausibility error
		3	Multiple Stage Switch engine torque limitation curve; short circuit to battery
		4	Multiple Stage Switch engine torque limitation curve; short circuit to ground

Deutz TCD3.6 Engine Fault Codes

SPN = Suspect Parameter Number

ASPN = Alternate Suspect Parameter Number

FMI = Failure Mode Identifier

SPN	ASPN	FMI	Description
23470	64718	2	Pressure Relief Valve (PRV) forced to open
		7	Maximum rail pressure in limp home mode exceeded (PRV)
		11	Pressure Relief Valve (PRV) error; Rail pressure out of tolerance range
		12	Pressure Relief Valve (PRV) forced to open; system reaction initiated
		14	Pressure Relief Valve (PRV) is open Rail pressure out of tolerance range
23550	64798	12	T50 start switch active for too long
23601	64849	13	Sensor supply voltage monitor 3 error (ECU)
23602	64850	0	Fan control; out of range, system reaction initiated
23603	64851	9	Timeout Error of CAN-Receive-Frame AMB; Ambient Temperature Sensor
23605	64853	9	Timeout Error of CAN-Receive-Frame TSC1AE; Traction Control
23606	64854	9	Timeout Error of CAN-Receive-Frame TSC1AR; Retarder
23612	64860	12	ECU reported internal software error
		14	Softwarereset CPU Internal software error ECU
23613	64861	0	Rail pressure disrupted
		1	Minimum rail pressure exceeded (RailMeUn3)
		2	Setpoint of metering unit in overrun mode not plausible
23615	64863	3	Metering unit (Fuel-System); short circuit to battery
		4	Metering unit (Fuel-System); short circuit to ground
		5	Metering unit (Fuel-System); open load
		12	Metering unit (Fuel-System); powerstage over temperature
23619	64867	2	Physical range check high for exhaust gas temperature upstream (SCR-CAT)
23632	64880	0	Pressure overload of SCR-System
		1	Pressure build-up error SCR-System
		2	Metering control is not performed in time error
		16	Pump pressure SCR metering unit too high
		18	Pump pressure SCR metering unit too low
23633	64881	11	Nox conversion rate insufficient

Deutz TCD3.6 Engine Fault Codes

SPN = Suspect Parameter Number

ASPN = Alternate Suspect Parameter Number

FMI = Failure Mode Identifier

SPN	ASPN	FMI	Description
23698	64946	11	Shut off request from supervisory monitoring function
23704		12	Timeout Error of CAN-Transmit_Frame EEC3
23717	64965	12	Timeout Error of CAN-Transmit-Frame AmbCon; Weather environments
23718	64966	3	SCR main relay (primary side); short circuit to battery
		4	SCR main relay (primary side); short circuit to ground
		5	SCR main relay (primary side); open load
		12	SCR mainrelay; powerstage over temperature (only CV56B) SCR mainrelay; short circuit to battery (only CV56B) SCR mainrelay; short circuit to ground (only CV56B) SCR mainrelay; open load (only CV56B)
23719	64967	3	SCR heater urea supplymodule; short circuit to battery
		4	SCR heater urea supplymodule; short circuit to ground
		5	SCR heater relay urea supply module; open load
23720	64968	2	Urea supply module heater temperature; plausibility error
		8	Urea supply module heater temperature; signal disrupted
23721	64969	2	Urea supply module heater temperature; plausibility error
		8	Urea supply module temperature; signal disrupted
		11	Urea supply module temperature measurement not available
23722	64970	8	Urea supply module PWM signal; signal disrupted

Deutz TCD3.6 Engine Fault Codes

SPN = Suspect Parameter Number

ASPN = Alternate Suspect Parameter Number

FMI = Failure Mode Identifier

SPN	ASPN	FMI	Description
23723	64971	11	Detection of AdBlue filled SCR system in Init-State
23766	65014	9	Timeout Error of CAN-Receive-Frame Active TSC1AE
23767	65015	9	Timeout Error of CAN-Receive-Frame Passive TSC1AE
23768	65016	9	Timeout Error of CAN-Receive-Frame Active TSC1AR
23769	65017	9	Timeout Error of CAN-Receive-Frame Passive TSC1AR
23770	65018	9	Timeout Error of CAN-Receive-Frame Passive TSC1DE
23776	65024	9	Timeout Error of CAN-Receive-Frame TSC1TE - active
23777	65025	9	Passive Timeout Error of CAN-Receive-Frame TSC1TE; Setpoint
23778	65026	9	Active Timeout Error of CAN-Receive-Frame TSC1TR
23779	65027	9	Passive Timeout Error of CAN-Receive-Frame TSC1TR
23788	65036	0	Turbo charger wastegate; CAN Fehler
		12	Timeout Error of CAN-Transmit-Frame TrbCH; Status Wastegate
23793	65041	9	Timeout Error of CAN-Receive-Frame UAA10; AGS sensor service message
23794	65042	9	Timeout Error of CAN-Receive-Frame UAA11; AGS sensor data
23803	65051	9	Timeout Error of CAN-Receive-Frame RxEngPres; Status burner airpump
23867	65115	12	Timeout Error of CAN-Transmit-Frame UAA1 on CAN 2; Burner Air Pump Control
23895	65143	13	Check of missing injector adjustment value programming (IMA) injector 1 (in firing order)
23896	65144	13	check of missing injector adjustment value programming (IMA) injector 2 (in firing order)
23897	65145	13	check of missing injector adjustment value programming (IMA) injector 3 (in firing order)
23898	65146	13	check of missing injector adjustment value programming (IMA) injector 4 (in firing order)
23899	65147	13	check of missing injector adjustment value programming (IMA) injector 5 (in firing order)
23900	65148	13	check of missing injector adjustment value programming (IMA) injector 6 (in firing order)
23910	65158	0	Air Pump; internal error
		6	Air Pump; over current
		7	Air pump; CAN communication interrupted no purge function available
		9	Air Pump; CAN communication lost
		12	Air Pump; internal error
		14	Air pump doesn't achieve air mass flow setpoint

Deutz TCD3.6 Engine Fault Codes

SPN = Suspect Parameter Number

ASPN = Alternate Suspect Parameter Number

FMI = Failure Mode Identifier

SPN	ASPN	FMI	Description
23911	65159	0	Burner dosing valve (DV2); overcurrent at the end of the injection phase
		3	Burner dosing valve (DV2); short circuit to battery
		4	Burner dosing valve (DV2); short circuit to ground
		7	Burner dosing valve (DV2); blocked closed
		11	Burner dosing valve (DV2); short circuit high side powerstage
		12	Burner dosing valve (DV2); powerstage over temperature
23912	65160	0	Physical range check high for burner dosing valve (DV2) downstream pressure; shut off regeneration
		1	Physical range check low for burner dosing valve (DV2) downstream pressure; shut off regeneration. When burner injector is actuated, the measured pressure does not rise above ca. 1250mbar abs (expected: ca. 2400mbar).
		2	Burner dosing valve (DV2) downstream pressure sensor; plausibility error
		3	Sensor error burner dosing valve (DV2) downstream pressure sensor; signal range check high
		4	Sensor error burner dosing valve (DV2) downstream pressure sensor; signal range check low
23913	65161	3	Sensor error glow plug control diagnostic line voltage; signal range check high
		4	Sensor error glow plug control diagnostic line voltage; signal range check low
23914	65162	3	Glow plug control; short circuit to battery
		4	Glow plug control; short circuit to ground
		5	Glow plug control; open load
		11	Glow plug control; internal error
		12	Glow plug control; powerstage over temperature
23915	65163	0	HCl dosing valve (DV1); overcurrent at the end of the injection phase
		3	HCl dosing valve (DV1); short circuit to battery
		4	HCl dosing valve (DV1); short circuit to ground
		7	HCl dosing valve (DV1); blocked
		11	HCl dosing valve (DV1); short circuit high side powerstage
		12	HCl dosing valve (DV1); powerstage over temperature
23916	65164	0	Physical range check high for HCl dosing valve (DV1) downstream pressure; shut off regeneration
		1	Physical range check low for HCl dosing valve (DV1) downstream pressure; shut off regeneration
		2	Sensor HCl dosing valve (DV1) downstream pressure; plausibility error
		3	Sensor error HCl dosing valve (DV1) downstream pressure; signal range check high
		4	Sensor error HCl dosing valve (DV1) downstream pressure; signal range check low

Deutz TCD3.6 Engine Fault Codes

SPN = Suspect Parameter Number

ASPN = Alternate Suspect Parameter Number

FMI = Failure Mode Identifier

SPN	ASPN	FMI	Description
23917	65165	0	Physical range check high for DV1 & DV2 upstream pressure; shut off regeneration
		1	Physical range check low for DV1 & DV2 upstream pressure; shut off regeneration
		2	Sensor DV1 & DV2 upstream pressure; plausibility error
		3	Sensor error DV1 & DV2 upstream pressure; signal range check high
		4	Sensor error DV1 & DV2 upstream pressure; signal range check low
23918	65166	0	Physical range check high for DV1 & DV2 upstream temperature; shut off regeneration
		1	Physical range check low for DV1 & DV2 upstream temperature; shut off regeneration
		2	Sensor DV1 & DV2 upstream temperature; plausibility error
		3	Sensor error DV1 & DV2 upstream temperature; signal range check high
		4	Sensor error DV1 & DV2 upstream temperature; signal range check low
23919	65167	0	Physical range check high for airpump pressure; shut off regeneration
		1	Physical range check low for airpump pressure; shut off regeneration
		2	Sensor airpump pressure; plausibility error
		3	Sensor error airpump pressure; signal range check high
		4	Sensor error airpump pressure; signal range check low
23920	65168	0	Physical range check high for exhaustgas back pressure burner; shut off regeneration
		1	Physical range check low for exhaustgas back pressure burner; shut off regeneration
		2	Sensor exhaustgas back pressure; plausibility error
		3	Sensor error exhaustgas back pressure burner; signal range check high
		4	Sensor error exhaustgas back pressure burner; signal range check low
23921	65169	0	Physical range check high for burner temperature
		1	Physical range check low for burner temperature
		2	Sensor burner temperature; plausibility error
		3	Sensor error burner temperature; signal range check high
		4	Sensor error burner temperature; signal range check low
		11	Sensor burner temperature; plausibility error
23922	65170	3	Burner shut of valve; short circuit to battery
		4	Burner shut of valve; short circuit to ground
		5	Burner shut off valve; open load
		7	Shut off valve: blocked
		12	Over temperature error on burner shut of valve

Deutz TCD3.6 Engine Fault Codes

SPN = Suspect Parameter Number

ASPN = Alternate Suspect Parameter Number

FMI = Failure Mode Identifier

SPN	ASPN	FMI	Description
23924		4	Short circuit to ground actuator relay 2
23925		3	Short circuit to battery error of actuator relay 3
		4	Short circuit to ground actuator relay 3
23926		4	Short circuit to ground actuator relay 4
23927		3	Short circuit to battery error of actuator relay 5
23929	65177	0	Fuel Balance Control integrator injector 1 (in firing order); maximum value exceeded
		1	Fuel Balance Control integrator injector 1 (in firing order); minimum value exceeded
23930	65178	0	Fuel Balance Control integrator injector 2 (in firing order); maximum value exceeded
		1	Fuel Balance Control integrator injector 2 (in firing order); minimum value exceeded
23931	65179	0	Fuel Balance Control integrator injector 3 (in firing order); maximum value exceeded
		1	Fuel Balance Control integrator injector 3 (in firing order); minimum value exceeded
23932	65180	0	Fuel Balance Control integrator injector 4 (in firing order); maximum value exceeded
		1	Fuel Balance Control integrator injector 4 (in firing order); minimum value exceeded
23933	65181	0	Fuel Balance Control integrator injector 5 (in firing order); maximum value exceeded
		1	Fuel Balance Control integrator injector 5 (in firing order); minimum value exceeded
23934	65182	0	Fuel Balance Control integrator injector 6 (in firing order); maximum value exceeded
		1	Fuel Balance Control integrator injector 6 (in firing order); minimum value exceeded
23935	65183	12	Timeout Error of CAN-Transmit-Frame EEC3VOL1; Engine send messages
23936	65184	12	Timeout Error of CAN-Transmit-Frame EEC3VOL2; Engine send messages
23938	65186	9	Timeout Error (BAM to packet) for CAN-Receive-Frame AT1IGCVol1 information; factors & Sensorcalibration for NOX Sensor (SCR-system upstream cat; DPF- system downstream cat)
23939	65187	9	Timeout Error (BAM to BAM) for CAN-Receive-Frame AT1IGCVol1 information; factors & Sensorcalibration for NOX Sensor (SCR-system upstream cat; DPF- system downstream cat)
23940	65188	9	Timeout Error (PCK2PCK) for CAN-Receive-Frame AT1IGCVol1 information; factors & Sensorcalibration for NOX Sensor (SCR-system upstream cat; DPF-system downstream cat)
23941	65189	9	Timeout Error (BAM to packet) for CAN-Receive-Frame AT1OGCVol2 information; factors & Sensorcalibration for NOX Sensor (SCR-system downstream cat; DPF- system downstream cat)
23942	65190	9	Timeout Error (BAM to BAM) for CAN-Receive-Frame AT1OGCVol2 information; factors & Sensorcalibration for NOX Sensor (SCR-system downstream cat; DPF- system downstream cat)

Deutz TCD3.6 Engine Fault Codes

SPN = Suspect Parameter Number

ASPN = Alternate Suspect Parameter Number

FMI = Failure Mode Identifier

SPN	ASPN	FMI	Description
23943	65191	9	Timeout Error (PCK2PCK) for CAN-Receive-Frame AT1OGCVol2 information; factors & Sensorcalibration for NOX Sensor (SCR-system downstream cat; DPF- system downstream cat)
23946	65194	0	Zerofuel calibration injector 1 (in firing order); maximum value exceeded
		1	Zerofuel calibration injector 1 (in firing order); minimum value exceeded
23947	65195	0	Zerofuel calibration injector 2 (in firing order); maximum value exceeded
		1	Zerofuel calibration injector 2 (in firing order); minimum value exceeded
23948	65196	0	Zerofuel calibration injector 3 (in firing order); maximum value exceeded
		1	Zerofuel calibration injector 3 (in firing order); minimum value exceeded
23949	65197	0	Zerofuel calibration injector 4 (in firing order); maximum value exceeded
		1	Zerofuel calibration injector 4 (in firing order); minimum value exceeded
23950	65198	0	Zerofuel calibration injector 5 (in firing order); maximum value exceeded
		1	Zerofuel calibration injector 5 (in firing order); minimum value exceeded
23951	65199	0	Zerofuel calibration injector 6 (in firing order); maximum value exceeded
		1	Zerofuel calibration injector 6 (in firing order); minimum value exceeded
23960	65208	0	EGR cooler downstream temperature; out of range, system reaction initiated
		1	EGR cooler downstream temperature; out of range, system reaction initiated
			Exhaust gas temperature EGR downstream; out of range, system reaction initiated
			Exhaust gas temperature EGR downstream; out of range, system reaction initiated
23973	65221	14	SCR Tamper detection; derating timer below limit 1
23974	65222	14	SCR Tamper detection; derating timer below limit 2
23975	65223	14	Urea quality; derating timer below limit 1
23976	65224	14	Urea qulaity; derating timer below limit 2
23977	65225	14	Urea tank level; derating timer below limit 1
23978	65226	14	Urea tank level; derating timer below limit 2
23980	65228	14	Bad quality of reduction agent detected
23981	65229	11	Urea-tank without heating function (heating phase)
23982	65230	0	Powerstage diagnosis disabled; high battery voltage
		1	Powerstage diagnosis disabled; low battery voltage

Deutz TCD3.6 Engine Fault Codes

SPN = Suspect Parameter Number

ASPN = Alternate Suspect Parameter Number

FMI = Failure Mode Identifier

SPN	ASPN	FMI	Description
23984		3	UB6; Short circuit to battery error of actuator relay 6
23986		4	Actuator relay 5; voltage measured by ECU is out of target range
23987		4	Actuator relay 6; voltage measured by ECU is out of target range
23988	65236	3	Charging lamp; short circuit to battery
		4	Charging lamp; short circuit to ground
		5	Charging lamp; open load
		12	Charging lamp; over temperature
23989	65237	0	Fuel Balance Control integrator injector 7 (in firing order); maximum value exceeded
		1	Fuel Balance Control integrator injector 7 (in firing order); minimum value exceeded
23990	65238	0	Fuel Balance Control integrator injector 8 (in firing order); maximum value exceeded
		1	Fuel Balance Control integrator injector 8 (in firing order); minimum value exceeded
23992	65240	9	Timeout Error of CAN-Receive-Frame DM19Vol1; NOX sensor upstream
23993	65241	9	Timeout Error of CAN-Receive-Frame DM19Vol2; NOX sensor downstream
23995	65243	13	check of missing injector adjustment value programming (IMA) injector 7 (in firing order)
23996	65244	13	check of missing injector adjustment value programming (IMA) injector 8 (in firing order)
23998	65246	4	Injector cylinder bank 2 slave; short circuit
23999	65247	12	Injector powerstage output Slave defect
24000	65248	3	Injector 7 (in firing order); short circuit
		4	High side to low side short circuit in the injector 7 (in firing order)
		5	Injector 7 (in firing order); interruption of electric connection
24001	65249	3	Injector 8 (in firing order); short circuit
		4	High side to low side short circuit in the injector 8 (in firing order)
		5	Injector 8 (in firing order); interruption of electric connection
24004	65252	12	Too many recognized misfires in cylinder 7 (in firing order)
24005	65253	12	Too many recognized misfires in cylinder 8 (in firing order)

Deutz TCD3.6 Engine Fault Codes

SPN = Suspect Parameter Number

ASPN = Alternate Suspect Parameter Number

FMI = Failure Mode Identifier

SPN	ASPN	FMI	Description
24011	65259	0	Zerofuel calibration injector 7 (in firing order); maximum value exceeded
		1	Zerofuel calibration injector 7 (in firing order); minimum value exceeded
24012	65260	0	Zerofuel calibration injector 8 (in firing order); maximum value exceeded
		1	Zerofuel calibration injector 8 (in firing order); minimum value exceeded
24013	65261	7	Burner operation disturbed
24014	65262	1	Air pressure glow plug flush line; below limit
24016	65264	2	Air Pump; air flow is not plausible
		11	HFM sensor; electrical fault
24017	65265	12	Spark plug control unit (SPCU); internal error
24018	65266	14	DPF wasn't regenerated, power reduction phase 1 (manuell regeneration request)
24019	65267	11	Air Pump; air lines blocked
24020	65268	14	Engine power; Not enough oxygen for regeneration
24021	65269	11	Burner fuel line pipe leak behind Shut Off Valve
24022	65270	14	DPF wasn't regenerated, power reduction phase 2 (manuell regeneration request)
24023	65271	14	DPF wasn't regenerated, warning condition (manuell regeneration mode)
24024	65272	11	Deviation of the exhaust gas temperature setpoint to actual value downstream (DOC) too high
24025	65273	5	DPF system; operating voltage error
		14	Particulate filter; regeneration not succesful
24028	65276	2	CAN message PROEGRActr; plausibility error
24029	65277	2	Timeout Error of CAN-Receive-Frame ComEGRActr - exhaust gas recirculation positioner
24030	65278	7	EGR actuator; internal error
24031	65279	13	EGR actuator; calibration error
24032	65280	2	EGR actuator; status message "EGRCust" is missing
24033	65281	7	EGR actuator; due to overload in Save Mode
24034	65282	3	Disc separator; short circuit to battery
		4	Disc separator; short circuit to ground
		5	Disc Separator; open load
		12	Disc Separator; powerstage over temperature

Deutz TCD3.6 Engine Fault Codes

SPN = Suspect Parameter Number

ASPN = Alternate Suspect Parameter Number

FMI = Failure Mode Identifier

SPN	ASPN	FMI	Description
24035	65283	12	Injector diagnostics; time out error in the SPI communication
24036	65284	12	Injector diagnostics Slave; time out error in the SPI communication
24037	65285	3	Ashlamp; short circuit to battery
		4	Ashlamp; short circuit to ground
		5	Ashlamp; open load
24038	65286	9	Timeout error of CAN-Receive-Frame ComMS_Sys1TO (error memory Slave); Master-Slave internal CAN message
24039	65287	9	Timeout error of CAN-Receive-Frame ComMS_Sys2TO (error memory Slave); Master-Slave internal CAN message
24040	65288	9	Timeout error of CAN-Receive-Frame ComMS_Sys3TO (error memory Slave); Master-Slave internal CAN message
24041	65289	9	Timeout error of CAN-Receive-Frame ComMS_Sys4TO (error memory Slave); Master-Slave internal CAN message
24042	65290	9	Timeout error of CAN-Receive-Frame ComMS_Sys5TO (error memory Slave); Master-Slave internal CAN message
24043	65291	9	Timeout error of CAN-Receive-Frame ComMS_Sys6TO (error memory Slave); Master-Slave internal CAN message
24044	65292	9	CAN message ComMS_Sys7 not received from slave
24045	65293	9	Master-Slave CAN; Message-Counter-Error of CAN-Receive-Frame ComMSMoFOvR
24046	65294	9	Master-Slave CAN; Checksum-Error of CAN-Receive-Frame ComMSMoFOvR
24047	65295	9	Master-Slave CAN; Message-Length-Error of CAN-Receive-Frame ComMSMoFOvR
24048	65296	9	Timeout error CAN message ComMSMoFOvR1TO error memory Slave
24049	65297	9	Message copy error in the Master / Slave data transfer
24052	65300	11	MS ECU reported internal error
24055	65303	4	Spark Plug Control Unit (SPCU); short circuit to ground
24057	65305	2	Electric fuel pump; fuel pressure build up error
24062	65310	12	EAT-system HMI disrupted
24063		3	SCR main relay; short circuit to battery
		4	SCR heater main relay load side (K31 on heating valve (Y31))
		5	SCR heater return line; open load or SCR main relay not connected; or SCR heater pressureline; open load or SCR or SCR relay for suction line not connected or SCR heater supply module; open load or SCR heater tank; open load
		12	DEF supply module, time for defrosting too long or DEF tank, time for defrosting too long

Deutz TCD3.6 Engine Fault Codes

SPN = Suspect Parameter Number

ASPN = Alternate Suspect Parameter Number

FMI = Failure Mode Identifier

SPN	ASPN	FMI	Description
24065		0	Pressure sensor upstream SCR-CAT, pressure above upper physical threshold
		1	Pressure sensor upstream SCR-CAT, pressure below lower physical threshold
		2	Pressure sensor upstream SCR-CAT, plausibility error
		3	Pressure sensor upstream SCR-CAT, short circuit battery or open load
		4	Pressure sensor upstream SCR-CAT, short circuit ground
24067		0	DEF supply module, heater temperature above upper physical threshold
		1	DEF supply module, heater temperature below lower physical threshold
		2	Supply module heater temperature, plausibility error
24068	65316	2	Master ECU and Slave ECU have been identified as the same types
24069	65317	9	Timeout Error of CAN-Receive-Frame MSMon_FidFCCTO; Master-Slave CAN communication faulty
24074		9	NOx sensor downstream SCR-CAT, sensor internally open load
24075		11	NOx sensor downstream SCR-CAT, sensor internally short circuit
24076		9	NOx sensor downstream SCR-CAT, sensor internally open line
24077		11	NOx sensor upstream SCR-CAT, sensor internally short circuit
24078		9	NOx sensor downstream SCR-CAT, lambda value above upper physical threshold
24079		9	NOx sensor downstream SCR-CAT, lambda value below lower physical threshold
24080		9	NOx sensor upstream SCR-CAT, lambda value above upper physical threshold
24081		9	NOx sensor upstream SCR-CAT, lambda value below lower physical threshold
24083		9	NOx sensor downstream SCR-CAT, NOx value below minimum value
24085		9	NOx sensor upstream SCR-CAT, NOx value below lower physical threshold

Deutz TCD3.6 Engine Fault Codes

SPN = Suspect Parameter Number

ASPN = Alternate Suspect Parameter Number

FMI = Failure Mode Identifier

SPN	ASPN	FMI	Description
24097	65345	9	Timeout error of CAN-Transmit-Frame DPFBrnAirPmpCtl
24098	65346	9	Timeout error of CAN-Transmit-Frame ComDPFBrnPT
24099	65347	9	Timeout error of CAN-Transmit-Frame ComDPFC0
24100	65348	9	Timeout error of CAN-Transmit-Frame ComDPFHisDat
24101	65349	9	Timeout error of CAN-Transmit-Frame ComDPFTstMon
24102	65350	9	Timeout error of CAN-Receive-Frame ComRxDPFBrnAirPmpCtl
24103	65351	9	Timeout error of CAN-Receive-Frame ComRxDPFBrnAirPmp
24104	65352	9	Timeout error of CAN-Receive-Frame ComRxDPFCtl
24105	65353	9	Timeout error of CAN-Transmit-Frame ComEGRMsFlw
24106	65354	9	Timeout error of CAN-Receive-Frame ComRxEGRMsFlw1
24107	65355	9	Timeout error of CAN-Receive-Frame ComRxEGRMsFlw2
24108	65356	9	Timeout error of CAN-Transmit-Frame ComEGRTVActr
24109	65357	9	Timeout error of CAN-Receive-Frame ComRxEGRTVActr
24110	65358	9	Timeout error of CAN-Transmit-Frame ComETVActr
24111	65359	9	Timeout error of CAN-Receive-Frame ComRxETVActr
24112	65360	9	Timeout ComITVActr
24113	65361	9	Timeout error of CAN-Receive-Frame ComRxITVActr
24114	65362	9	Timeout error of CAN-Transmit-Frame A1DOC
24115	65363	9	Timeout error of CAN-Transmit-Frame AT1S

Deutz TCD3.6 Engine Fault Codes

SPN = Suspect Parameter Number

ASPN = Alternate Suspect Parameter Number

FMI = Failure Mode Identifier

SPN	ASPN	FMI	Description
24116	65364	9	Timeout error of CAN-Transmit-Frame SCR2
24117	65365	9	Timeout error of CAN-Transmit-Frame SCR3
24118	65366	9	Timeout error of CAN-Receive-Frame ComRxCM0
24119	65367	9	Timeout error of CAN-Receive-Frame ComRxCustSCR2
24120	65368	9	Timeout error of CAN-Receive-Frame ComRxSCRHtDiag
24121	65369	9	Timeout error of CAN-Receive-Frame ComRxTrbChActr
24122	65370	9	Timeout error of CAN-Receive-Frame ComRxUQSens
24123	65371	9	Timeout error of CAN-Receive-Frame ComSCRHtCtl
24124	65372	9	Timeout error of CAN-Receive-Frame ComTxAT1IMG
24125	65373	9	Timeout error of CAN-Receive-Frame ComTxTrbChActr
24141		7	DEF dosing valve, dosing valve blocked
24147		7	SCR System, reverting valve blocked
		13	SCR System, pressure build up not possible
24152		2	Urea Quality Sensor, Timeout CAN message
24153		2	Urea tank level & urea tank temperature via CAN bus, timeout of CAN message
24156		9	Timeout error of CAN-Receive-Frame ComRxEBC2
24175		0	SCR-CAT, Nox emissions above minimum threshold
24177		7	SCR System, DEF suction line blocked
24178		7	SCR System, DEF pressure out of range
24190		14	Not enough urea in tank or low urea quality or hardware tampering failure is detected or hardware failure is detected
24191		14	A low DEF tank level or a low DEF quality is detected or hardware tampering or hardware failures
24193		8	The standstill-regeneration mode time exceeds the long limit threshold; Vehicle was too long or too often in standstill mode; Change oil and reset counter
24194		8	The standstill-regeneration mode time exceeds the short limit threshold; Vehicle was too long or too often within a short time in standstill mode; Change oil and reset counter
24195		14	Standstill request due to crystalization ignored too long

Perkins 1104 Engine Fault Codes

SPN = Suspect Parameter Number

FMI = Failure Mode Identifier

SPN	FMI	Description
91	2	Incorrect throttle switch inputs
	3	Throttle position sensor: voltage above normal or shorted high
	4	Throttle position sensor: voltage below normal or shorted low
	8	Throttle position sensor: abnormal frequency, pulse width or period
100	3	Engine oil pressure sensor: voltage above normal or shorted high
	4	Engine oil pressure sensor :voltage below normal or shorted low
102	3	Boost pressure sensor voltage: voltage above normal or shorted high
	4	Boost pressure sensor voltage: voltage below normal or shorted low
	10	No 5V to sender
105	3	Intake manifold temperature sensor: temperature above normal or shorted high
	4	Intake manifold temperature sensor: temperature below normal or shorted low
105	3	Intake manifold air temperature open/short to battery positive (+)
	4	Intake manifold air temperature short to ground
110	3	Engine coolant temperature open/short to battery positive (+)
	4	Engine coolant temperature short to ground

SPN	FMI	Description
157	3	Fuel rail pressure open/short to battery positive (+)
	4	Fuel rail pressure short to ground
168	0	System voltage high
	1	System voltage low
	2	ECM battery power intermittent/erratic
172	3	Air inlet temperature voltage high
	4	Air inlet temperature voltage low
174	2	Fuel temperature sensor: data erratic/intermittent or incorrect
	8	Engine speed signal abnormal
190	15	Engine speed: overspeed WARNING
	0	Engine overspeed
626	5	Ether start aid current low
	6	Ether start aid current high
630	2	System parameters incorrect
631	2	Personality module mismatch
637	11	Engine timing calibration invalid
637	139	Engine timing calibration required
639	9	J1939 data link communications
	12	J1939 data link malfunction
651	2	Cylinder #1 injector data incorrect
	5	Cylinder #1 injector open circuit
	6	Cylinder #1 injector short
	7	Cylinder #1 injector not responding
652	2	Cylinder #2 injector data incorrect
	5	Cylinder #2 injector open circuit
	6	Cylinder #2 injector short
	7	Cylinder #2 injector not responding

Perkins 1104 Engine Fault Codes

SPN = Suspect Parameter Number

FMI = Failure Mode Identifier

SPN	FMI	Description
653	2	Cylinder #3 injector data incorrect
	5	Cylinder #3 injector open circuit
	6	Cylinder #3 injector short
	7	Cylinder #3 injector not responding
654	2	Cylinder #4 injector data incorrect
	5	Cylinder #4 injector open circuit
	6	Cylinder #4 injector short
	7	Cylinder #4 injector not responding
678	3	8V DC supply short to battery positive (+)
	4	8V DC supply shorted to ground
723	8	Secondary engine speed signal abnormal
1188	5	Turbo wastegate drive current low
1196	9	Machine security system module non-communication
1347	5	Fuel rail pump output current low
	6	Fuel rail pump output current high
	7	Fuel rail pressure valve solenoid not responding
2882	2	Mode selector switch: data erratic/intermittent or incorrect
3509	3	5V DC power supply sensor short to battery positive (+)
	4	5V DC power supply sensor short to ground

Perkins 1100 Troubleshooting Manual

Genie part number 123583

Schematics



Observe and Obey:

- ☑ Troubleshooting and repair procedures shall be completed by a person trained and qualified on the repair of this machine
- ☑ Immediately tag and remove from service a damaged or malfunctioning machine.
- ☑ Repair any machine damage or malfunction before operating the machine.

Before Troubleshooting:

- ☑ Read, understand and obey the safety rules and operating instructions in the appropriate operator's manual on your machine.
- ☑ Be sure that all necessary tools and test equipment are available and ready for use.

About This Section

There are two groups of schematics in this section.

Electrical Schematics

⚠ WARNING

Electrocution/burn hazard. Contact with electrically charged circuits could result in death or serious injury. Remove all rings, watches and other jewelry.

Hydraulic Schematics

⚠ WARNING

Bodily injury hazard. Spraying hydraulic oil can penetrate and burn skin. Loosen hydraulic connections very slowly to allow the oil pressure to dissipate gradually. Do not allow oil to squirt or spray.

Fuse Panel Layout

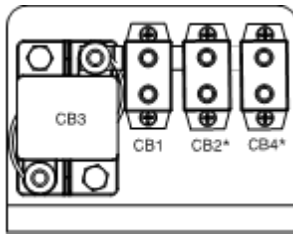

Deutz 74HP - Perkins T3 - Perkins T4i

- CB1- 50A- Control System Power
- *CB2 30A- Engine Power / ECM
- Deutz 74HP; Perkins T3
- *CB2 50A
- Perkins T4i
- CB3 60A- Glow Plugs
- *CB4 20A- Fuel Pump
- Deutz 74HP

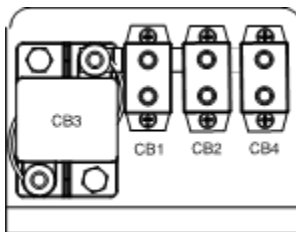

- Deutz 99HP
- CB4 50A-EAT Power
- CB2 50A- ECM Power
- CB1 50A-Control System Power
- CB3 60A-Glow Plugs

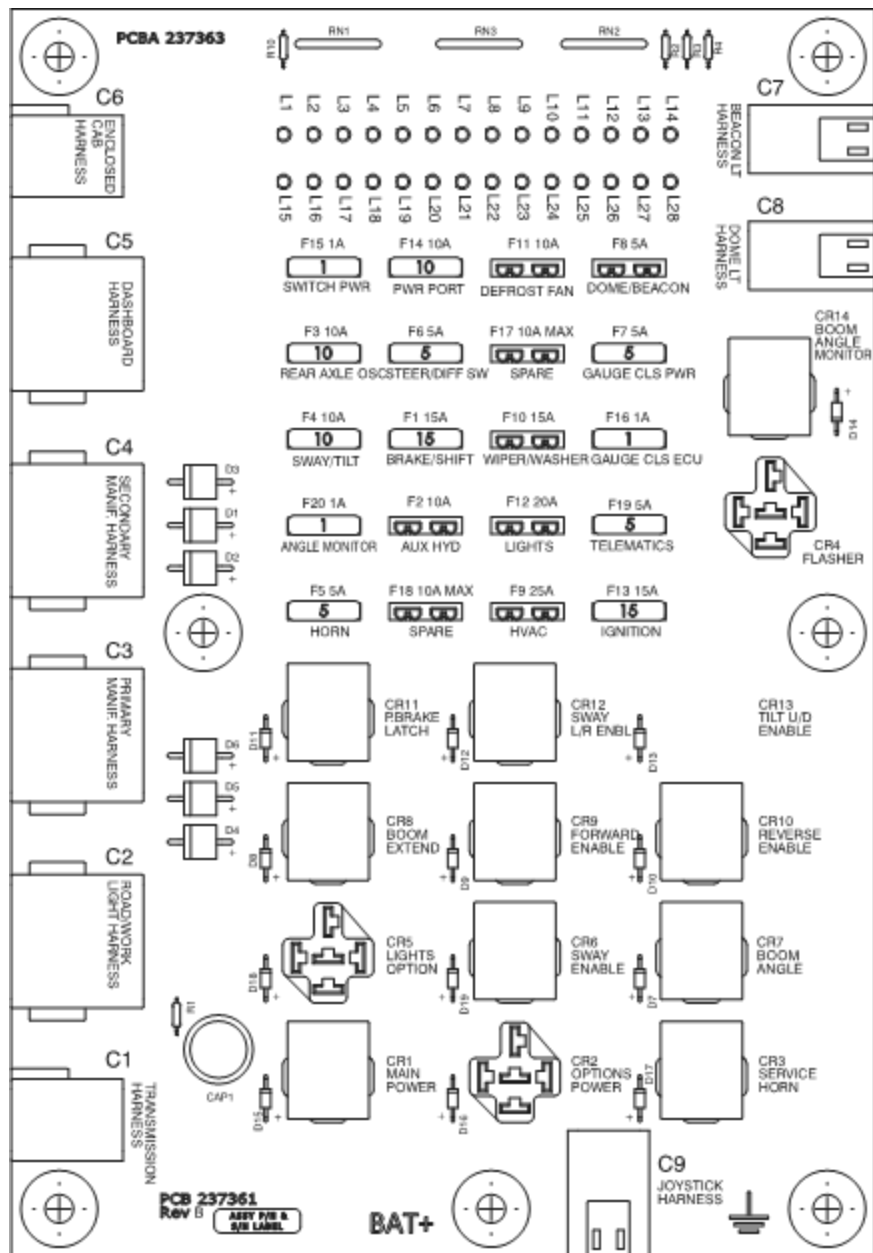

Fuse Board located in the Cab

Circuit Breakers located on the Battery Tray

Deutz TCD3.6 T4F Module

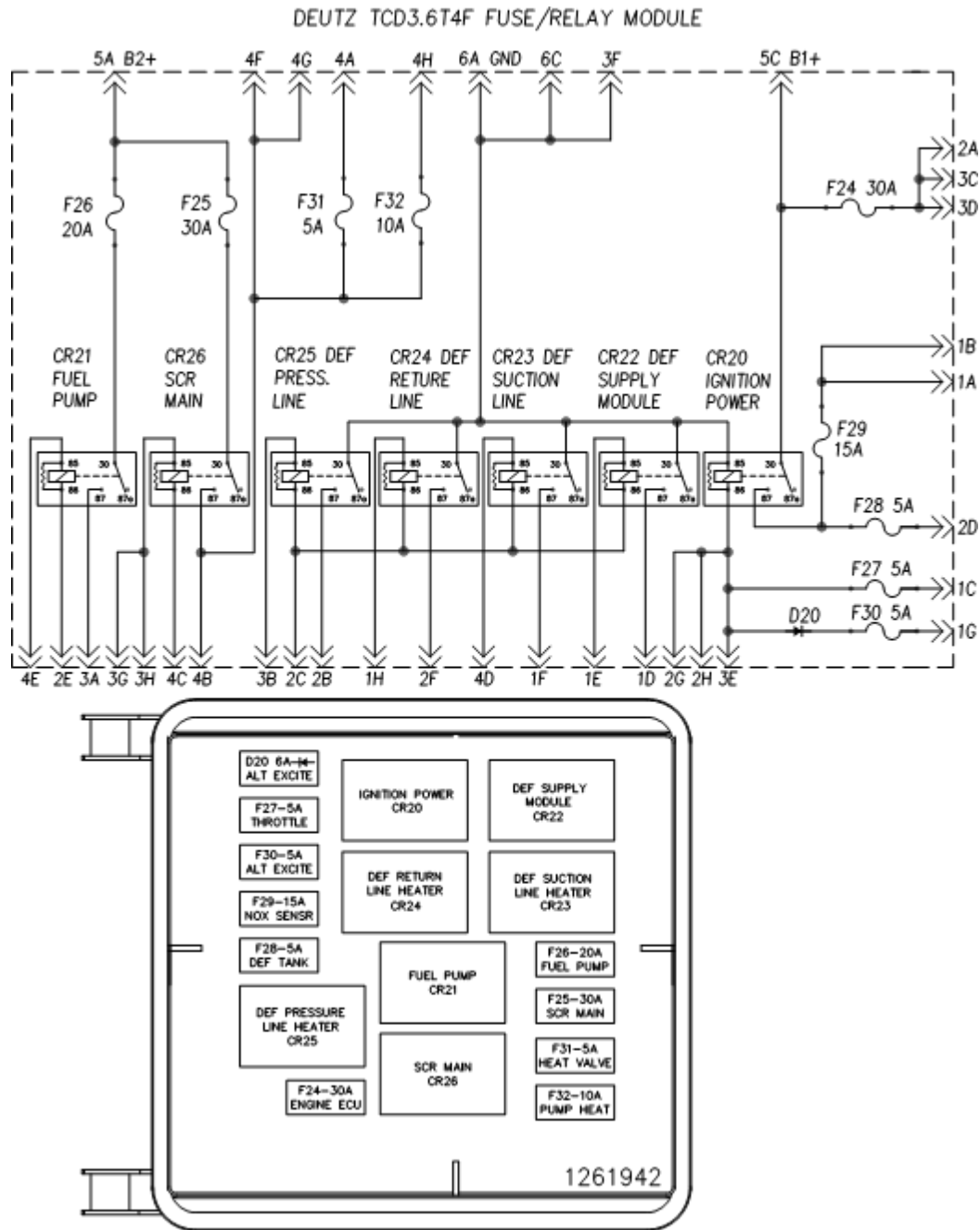

Deutz TCD3.6 T4F Engine only



Electrical Component & Wire Color Abbreviation Legend

Item	Description
ALT	Alternator
B	Battery
B1	Main Battery, 12V
CB	Circuit Breaker
CB1	50 Amp Circuit Breaker, ECS Power
CB2	30 Amp Circuit Breaker, Engine ECM
CB3	60 AMP Circuit Breaker, Glow Plugs
CB4	60 Amp Circuit Breaker, Fuel Pump
C	Capacitor
C1	4700 uf
CR	Control Relay
CR1	Main Power
CR2	Options Power
CR3	Service Horn
CR4	Flasher
CR5	Lights Option
CR6	Sway Enable
CR7	Boom Angle
CR9	Forward Enable
CR10	Reverse Enable
CR11	Parking Brake Latch
CR12	Sway Left/Right Enable
CR13	Tilt Up/Down Enable
CR14	Boom Angle Monitor
CR16/CR19	Condenser Fans
CR18	Telematics

Item	Description
D	Diode
EMS	Engine Management System
F	Fuse
F1	15 Amp - Parking Brake Switch
F2	10 Amp - Stabilizer Power
F3	10 Amp – Sway / Drive Enable
F4	10 Amp – Sway/Tilt Coil Power
F5	5 Amp - Horn
F6	5 Amp - Steer/Differential Switch
F7	5 Amp - Gauge Cluster Power
F8	5 Amp - Dome/Beacon Light
F9	25 Amp – HVAC
F10	15 Amp – Windshield Wiper/Washer
F11	10 Amp – Defrost Fan
F12	20 Amp – Lights
F13	15 Amp – Ignition
F14	10 Amp – Power Port
F15	1 Amp - Switch Power
F16	1 Amp – Gauge Cluster ECU
F19	5 Amp - Telematics
F20	1 Amp - Boom Angle Monitor
F21	15 Amp - Condenser Fan 1
F23	15 Amp - Condenser Fan 2
F23	15 Amp - Condesner Fan 2

Electrical Component & Wire Color Abbreviation Legend

Item	Description	Item	Description
L	LED Light	S	Switch
L1	Ignition Power ON	S1	Key Start Switch
L2	Options Power Relay ON	S2	Parking Brake Switch
L3	Horn Relay ON	S3	Boom Angle Switch
L4	Blinkers / Pilot Light ON	S5	Parking Brake Pressure Switch
L5	Road Lights, Work Lights ON	S6	Service Brake Pressure Switch
L6	Sway Enable Coil Power ON	S10	Steer Select Switch
L7	Boom Angle	S15	Horn Switch
L9	Brake Pressure ON	S16	Brake Light Pressure Switch
L10	Reverse ON	S17	Windshield Wiper Motor Switch
L11	Parking Brake Latch ON	S17	Windshield Washer Switch
L12	Sway Enable ON	S18	Windshield Wiper/Washer Motor Switch
L13	Tilt Circuit Power ON	S18	Skylight Wiper/Washer Switch
L14	Horn Power ON	S19	Dome Light Switch
L15	Cab, Tail Light Power ON	S21	Enclosed Cab Fan Switch
L16	Rear Axle Float Coil Power ON	S22	Road / Work Light Switch
L17	Boom Angle Relay ON	S23	Brake Pressure Warning Switch
L18	Parking Brake Pressure SW Power ON	S24	Transmission Oil Pressure Switch
L19	Forward Coil Power ON	S25	Transmission Oil Temp. Switch
L20	Reverse Coil Power ON	S26	Boom Light Switch
L21	PB Release Coil Power ON	S27	Telematics
L22	Sway L/R Enable Coil Power ON	TP	Throttle Pedal
L23	Tilt U/D Enable Coil Power ON	TSS	Turn Signal Shifter
L24	Forward Shift ON		
L25	Parking Brake Release OFF		
L26	Brake Light Power ON		
L27	Hazard Power ON		
L28	Boom Angle Switch ON		
M	Motor		
R	Resistor		

Electrical Component & Wire Color Abbreviation Legend













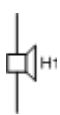





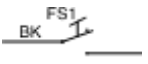

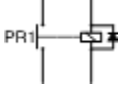

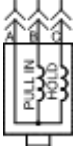

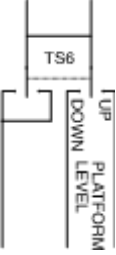

Item	Description
Y	Valve Coil
Y1	Sway Left Enable SV1
Y2	Tilt Up Enable SV2
Y3	Sway Right Enable SV3
Y4	Tilt Down Enable SV4
Y5	Parking Brake Release SV5
Y6	Differential Lock SV6
Y7	Rear Axle Float SV7
Y8	Rear Axle Fast SV8
Y9	Sway Enable SV9
YA	Auxiliary A
YB	Auxiliary B
YD	D Transmission
YE	E Transmission
YF	Transmission Forward
YR	Transmission Reverse
YD1A	4Wheel Steer SVD1A
YD1B	Crab Steer SVD1B
YLD	Left Stabilizer Down
YLU	Left Stabilizer Up
YRD	Right Stabilizer Down
YRU	Right Stabilizer Up

Electrical Component & Wire Color Abbreviation Legend

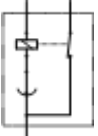
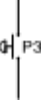
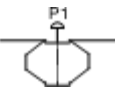
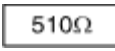
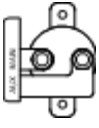



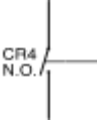





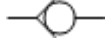

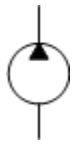

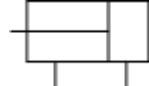

Wire Color Legend

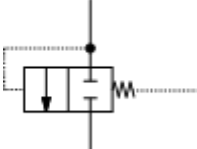
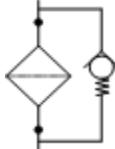
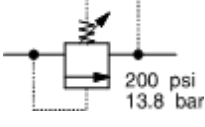
BL	Blue
BL/BK	Blue/Black
BL/RD	Blue/Red
BL/WH	Blue/White
BK	Black
BK/RD	Black/Red
BK/WH	Black/White
BK/YL	Black/Yellow
BR	Brown
GR	Green
GR/BK	Green/Black
GR/WH	Green/White
RD	Red
RD/BK	Red/Black
RD/WH	Red/White
OR	Orange
OR/BK	Orange/Black
OR/RD	Orange/Red
WH	White
WH/BK	White/Black
WH/RD	White/Red
YL	Yellow
OR/WH	Orange/White

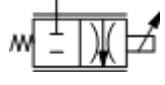
Electrical Symbol Legend

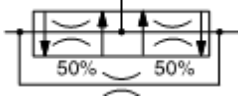
				
Battery	Coil, solenoid or relay	Horn or alarm	Flashing beacon	Gauge
				
Diode	Hour meter	LED	Fuse with amperage	Foot switch
				
T-circuits connect	Limit switch	Power relay	Coil with suppression	Fuel or RPM solenoid
				
Connection - no terminal	T-circuits connect at terminal	Circuits crossing no connection	Quick disconnect terminal	Circuit breaker with amperage
				
Key switch	Toggle Switch DPDT	Toggle Switch SPDT	Pump or Motor	Tilt sensor
				
Horn button - normally open	Emergency Stop button - normally closed	Resistor with ohm value	Battery separator	Gauge sending unit
				
Oil temperature switch normally open	Coolant temperature switch - normally open	Oil pressure switch normally closed	Control relay contact normally open	Diode starting aid, glow plug or flame ignitor

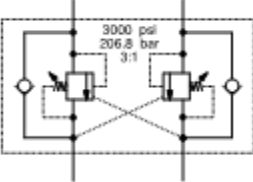
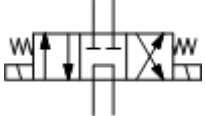
Hydraulic Symbols Legend

 <p>Orifice with size</p>	 <p>Check valve</p>	 <p>Shut off valve</p>	 <p>Brake</p>
 <p>Pump, fixed displacement</p>	 <p>Pump, bi-directional variable displacement</p>	 <p>Motor, bi-directional</p>	 <p>Motor, 2 speed bi-directional</p>
 <p>Cylinder, double acting</p>	 <p>Pump, prime mover (engine or motor)</p>	 <p>Shuttle valve, 2 position, 3 way</p>	 <p>Differential sensing valve</p>
 <p>Filter with bypass relief valve</p>	 <p>Relief valve with pressure setting</p>	 <p>Priority flow regulator valve</p>	 <p>Solenoid operated proportional valve</p>
 <p>Directional valve (mechanically activated)</p>	 <p>Flow divider/combiner valve</p>	 <p>Pilot operated 3 position, 3 way shuttle valve</p>	 <p>Solenoid operated 2 position, 3 way directional valve</p>
 <p>Counterbalance valve with pressure and pilot ratio</p>	 <p>Solenoid operated 3 position 4 way directional valve</p>	 <p>Solenoid operated 3 position, 4 way proportional directional valve</p>	 <p>Solenoid valve, 2 position 2 way</p>

Harness Map Legend

Base Harnesses

(included in all models)

Item	Description
1	Harness, Dashboard
2	Harness, Secondary Manifold
4	Harness, Transmission
5	Harness, Boom Angle Switch
6	Harness, Throttle Pedal
8	Harness, Backup Alarm
9	Assembly, Power Buss
11	Harness, PCB Ground
12	Harness, CAN Interface Jumper
13	Harness, Primary PVG

Engine Options Harnesses

Item	Description
14	Harness, Engine ECU, TCD3.6 T4F
15	Harness, Engine Base, TCD3.6 T4F
16	Cable, Battery, Red 2/0
17	Harness, Engine TCU, TDC3.6
18	Harness, Engine, TCD3.6
19	Cable, Battery, Red 2/0
20	Harness, Engine, 854E
21	Cable, Battery, Black 2/0
23	Cable, Battery, Red 2/0
24	Harness, Engine, 1104D
25	Harness, Diagnostic Plug Ext.
26	Harness, T4F User Interface
28	Harness, Connector Ext.
29	Harness, Connector Ext. T3

Beacon Light Option Harnesses

Item	Description
47	Harness, Beacon Light
48	Harness, Power, Beacon Light

3rd Gear Lockout Option Harness

Item	Description
49	Harness, 3rd Gear Bypass

Work Light Option Harnesses

Item	Description
30	Harness, Light, Led, Clear, 5" Round
31	Harness Cab Light Power
33	Harness, Backup Light
34	Harness, Boom Light Power
39	Harness, Work Lights

Road Light Option Harnesses

Item	Description
30	Harness, Light, Led, Clear, 5" Round
31	Harness, Cab Light Power
32	Harness, Taillight LED
33	Harness, Backup Light
34	Harness, Boom Light Power
35	Harness, Road Lights
36	Harness, Front Lights Power
37	Harness, light, drive, clear, 3led
38	Harness, Light, Turn Signal, Amber

Enclosed Cab With HVAC Option Harnesses

Item	Description
40	Harness, Enclosed Cab
41	Harness, Cab Fan
42	Harness, Power, Dome Light
43	Dome Light With Connector
45	Harness, Cab A/C
46	Harness, A/C

Enclosed Cab With Heat Option Harnesses

Item	Description
40	Harness, Enclosed Cab
41	Harness, Cab Fan
42	Harness, Power, Dome Light
43	Dome Light With Connector
44	Harness, Cab Heater

Rear Proximity Alarm Option

Item	Description
50	Harness, Rear Prox Alarm, GTH

**Harness Map - Control System Power-
Electronic Joystick**

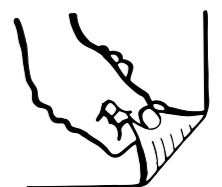

Harness Map - Control System Ground Electronic Joystick

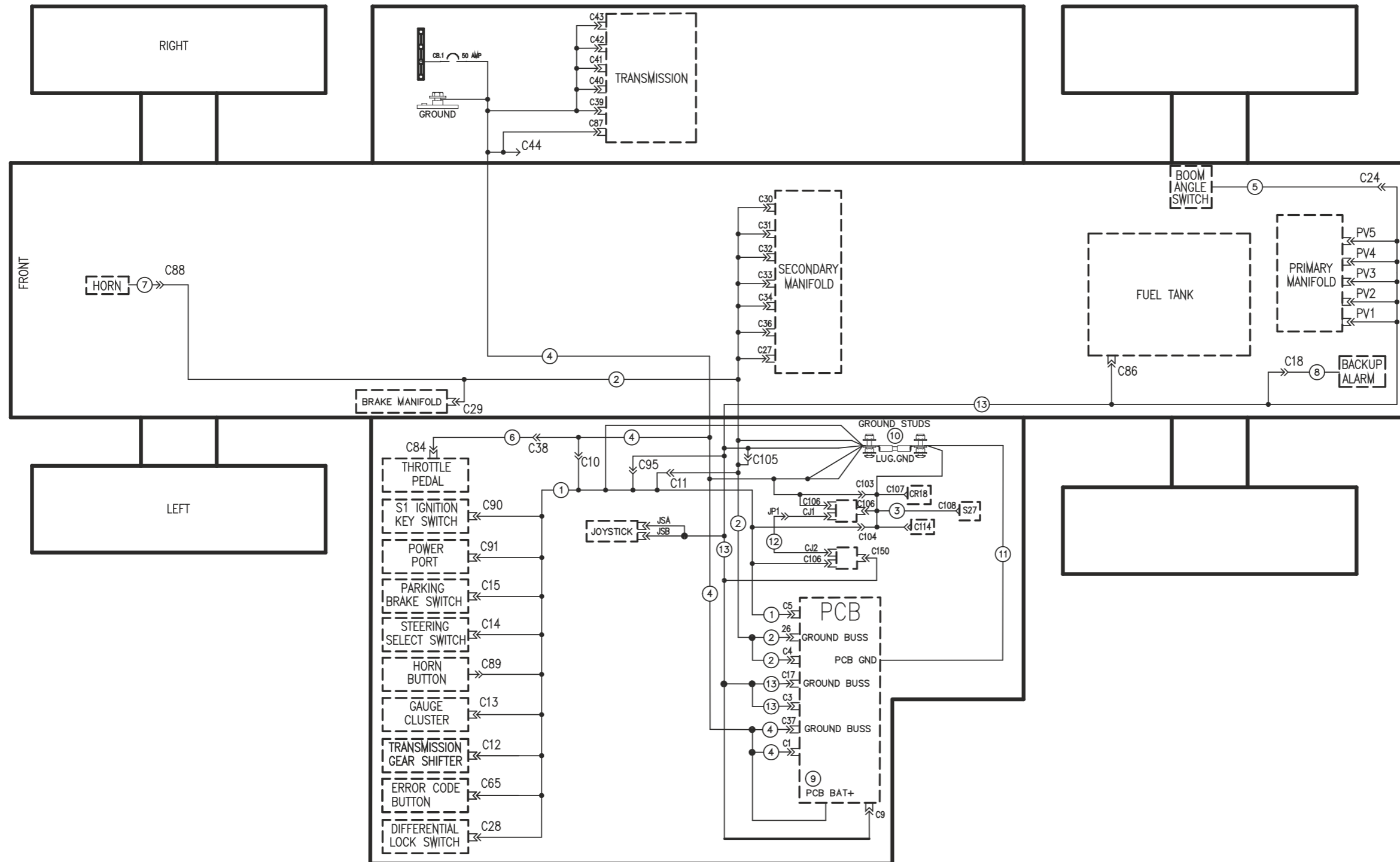

Harness Map - Beacon, Proximity Alarm and 3rd Gear Lockout

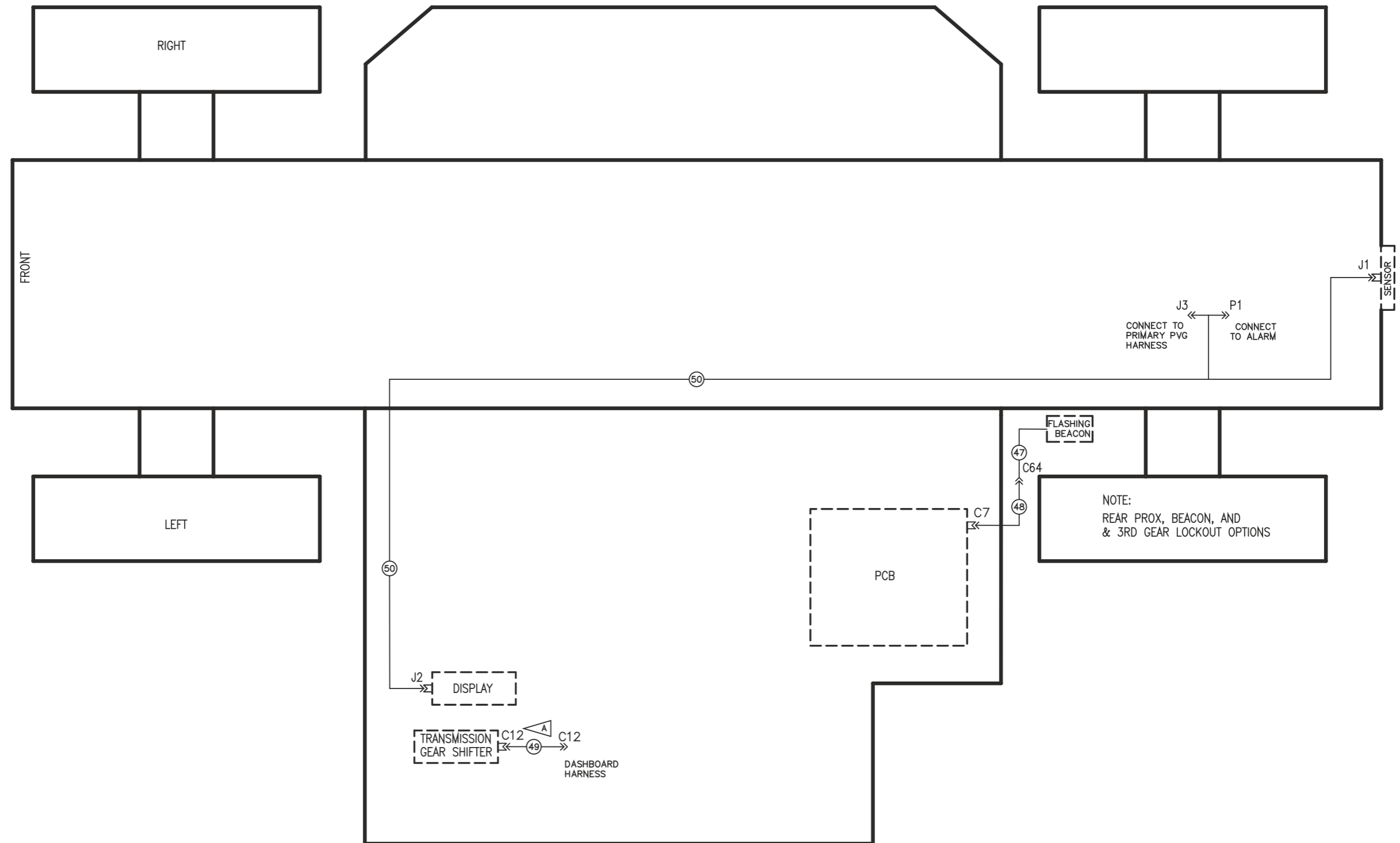

Harness Map - Beacon, Proximity Alarm and 3rd Gear Lockout

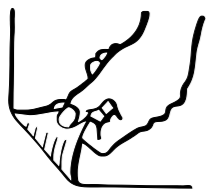

**Harness Map - Deutz TCD3.6 Engine
Battery Power and Ground**

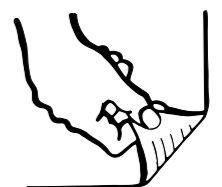

Harness Map - Deutz TCD3.6 Engines Battery Power and Ground

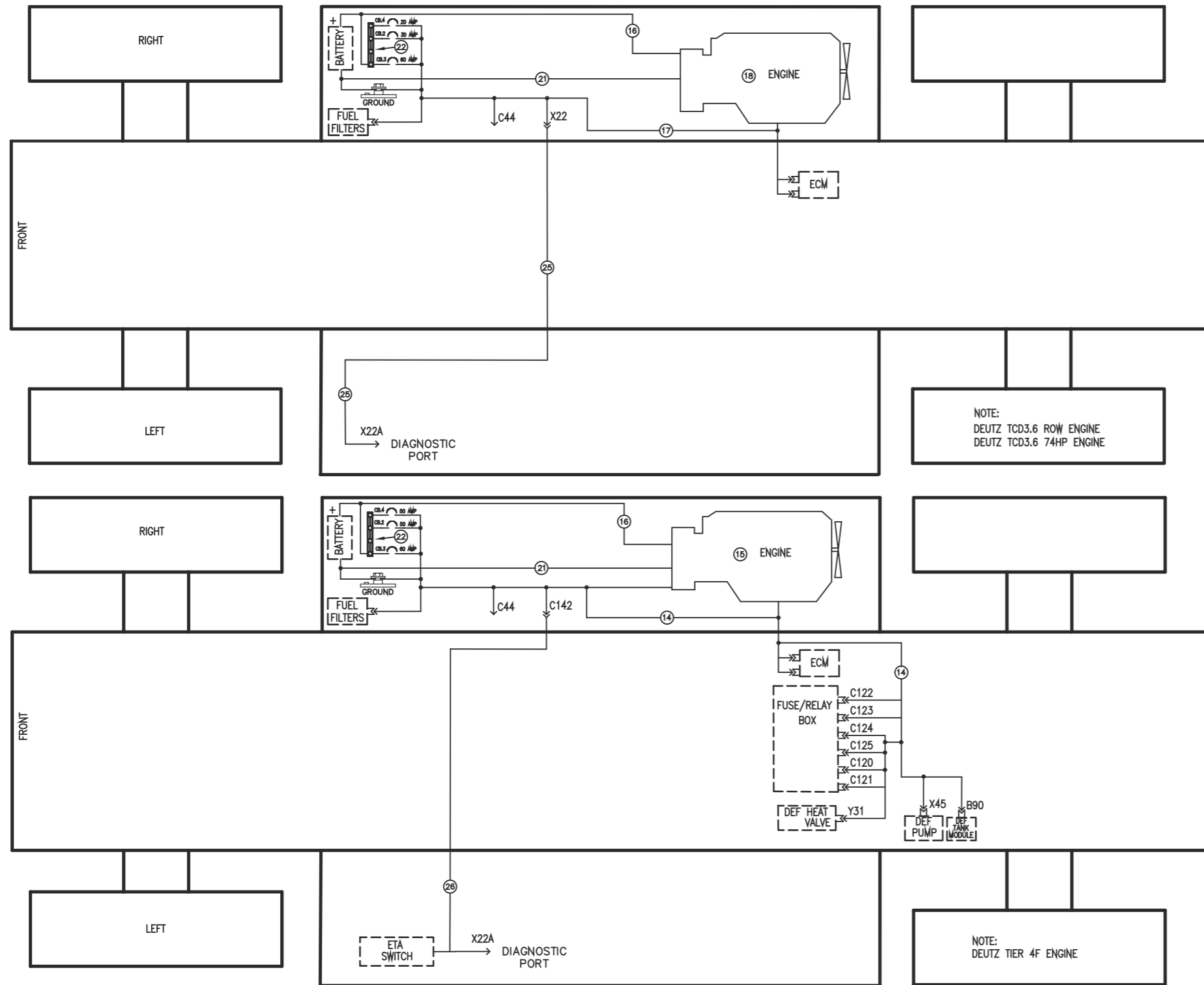

Harness Map - Perkins Engines Battery Power and Ground

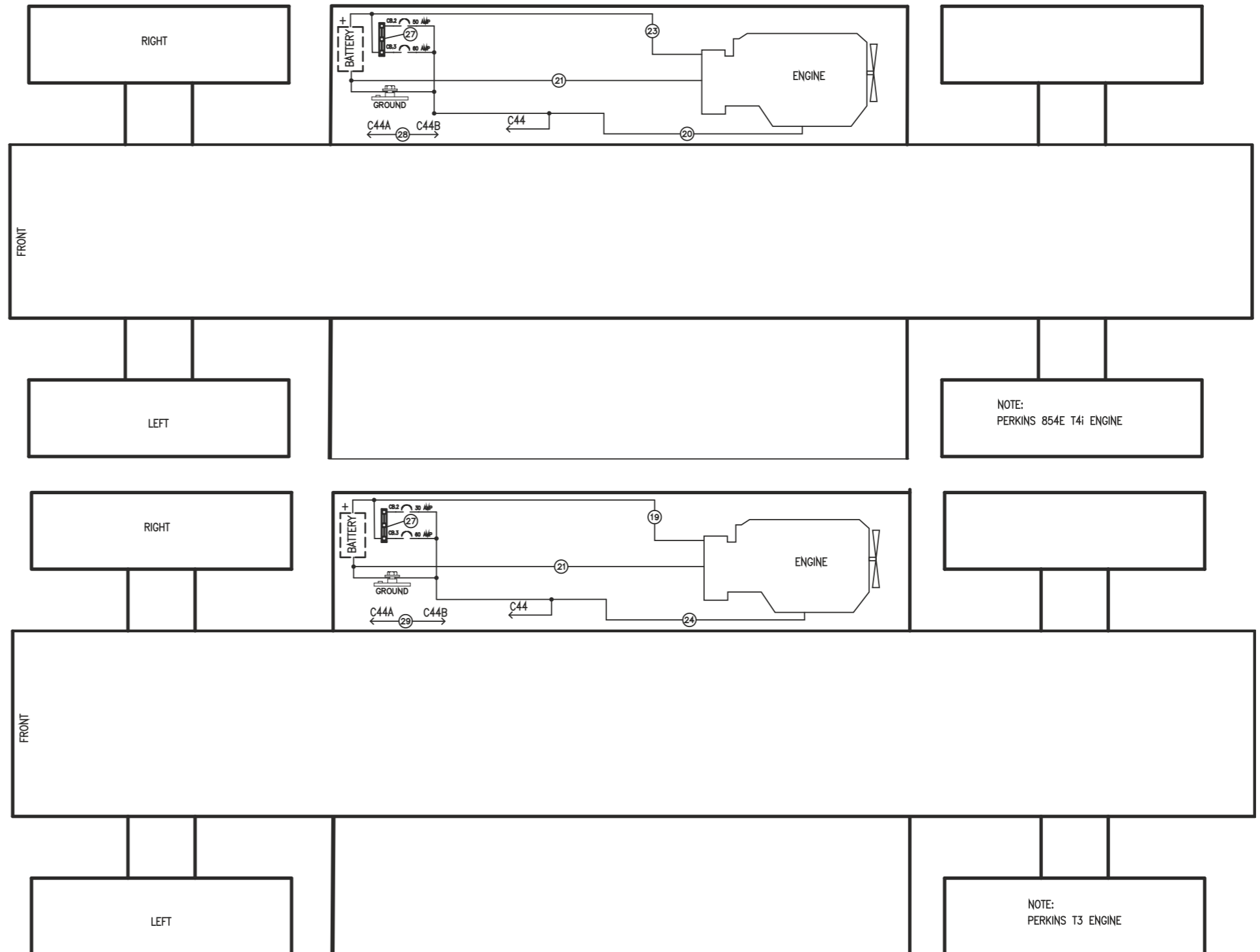

Harness Map - Perkins Engines Battery Power and Ground

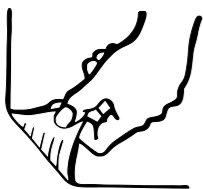

Harness Map - Options Work Lights

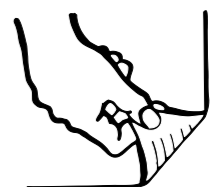

Harness Map - Options Work Lights

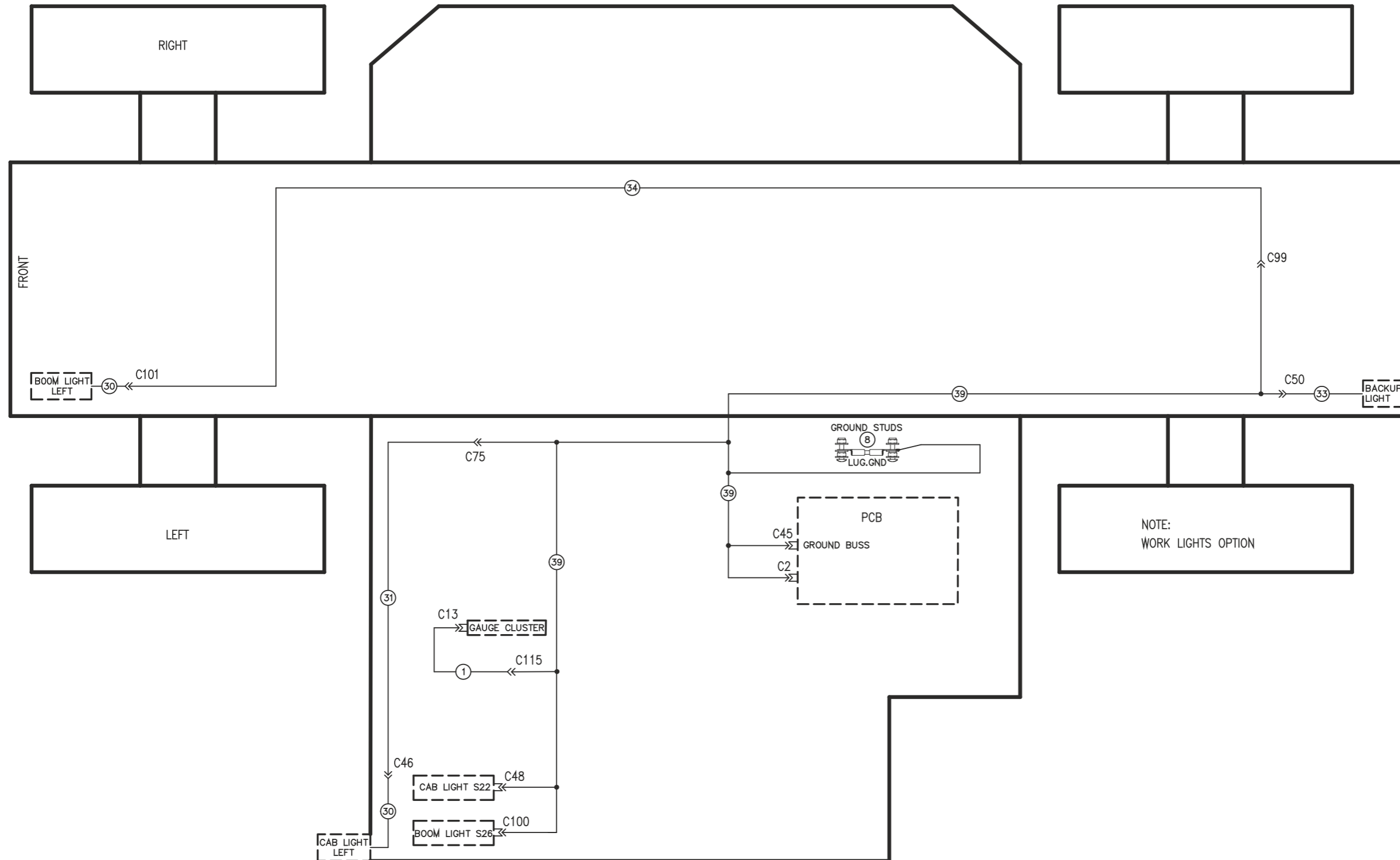

Harness Map - Options Road Lights

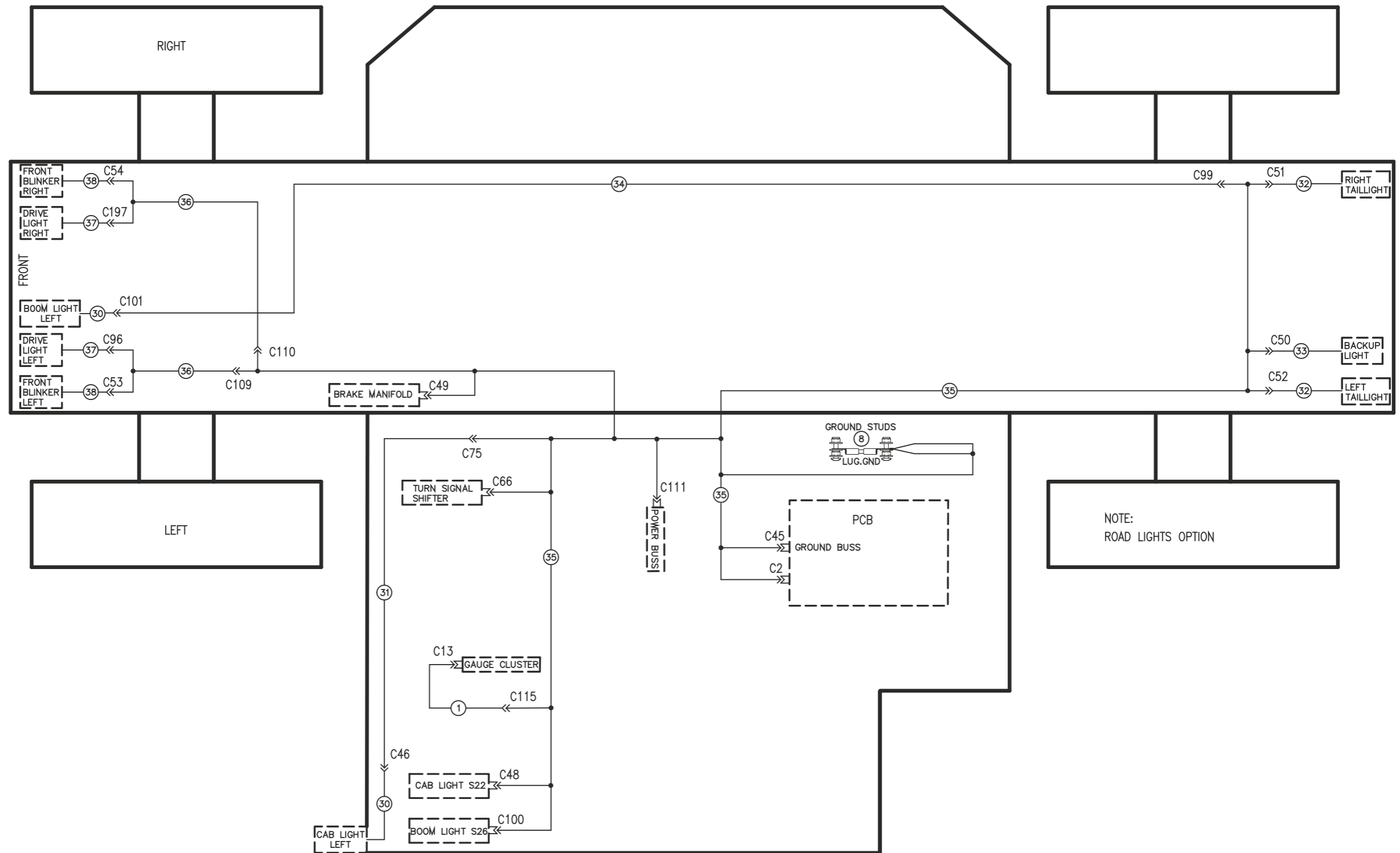

Harness Map - Options Road Lights

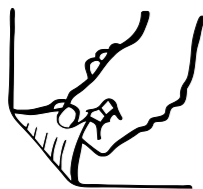

Harness Map - Options Enclosed Cab with Heater

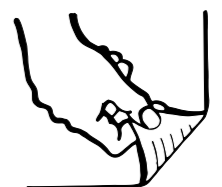

Harness Map - Options Enclosed Cab with Heater

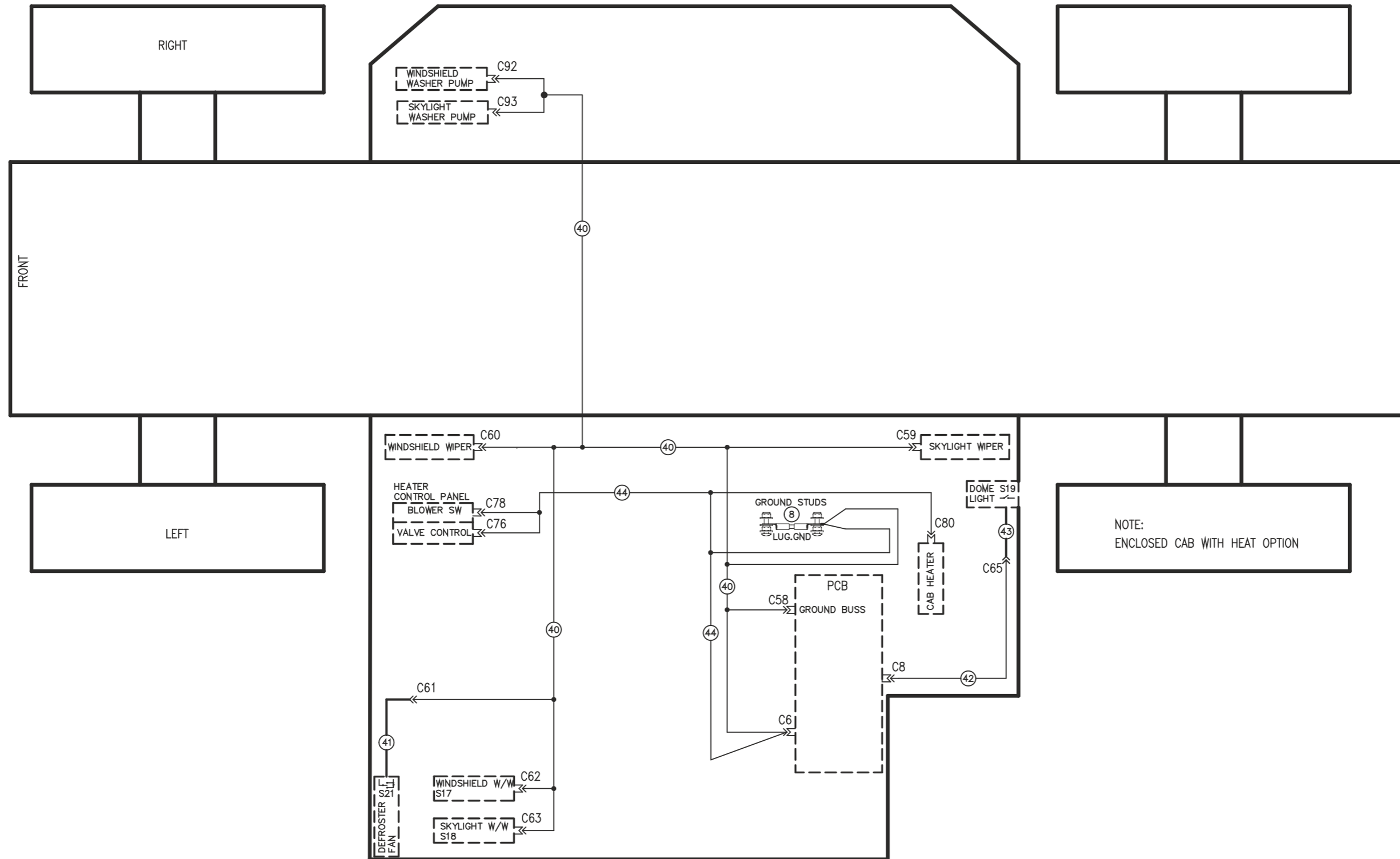

Harness Map - Options Enclosed Cab with HVAC

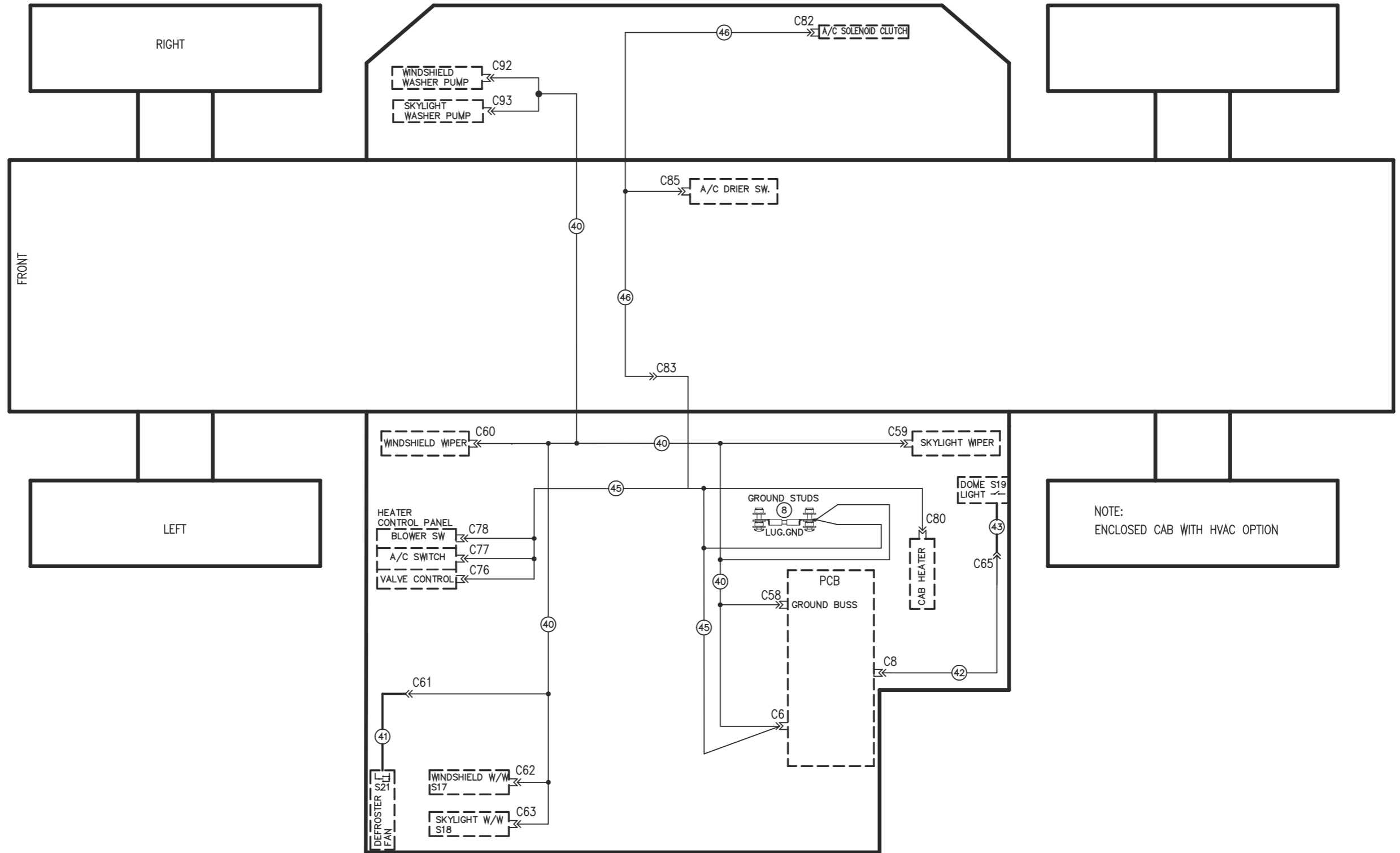

Harness Map - Options Enclosed Cab with HVAC

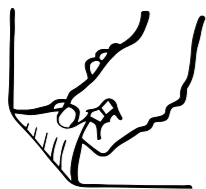

Electrical Schematic
(from GTH08E-11500 to 13228)

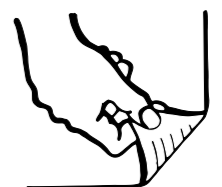

Electrical Schematic (from GTH08E-11500 to 13228)

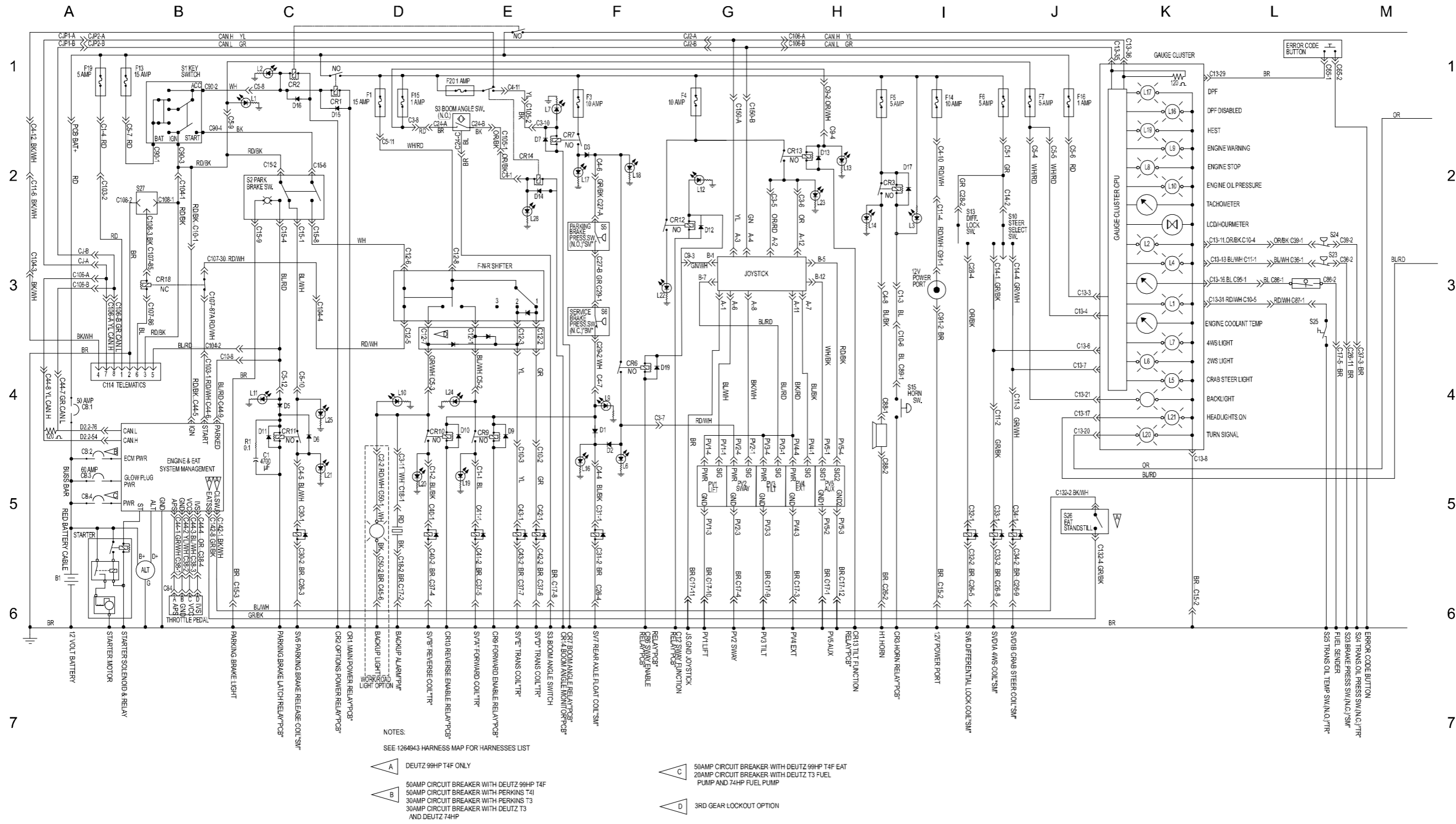

Electrical Schematic (from GTH08E-11500 to 13228)

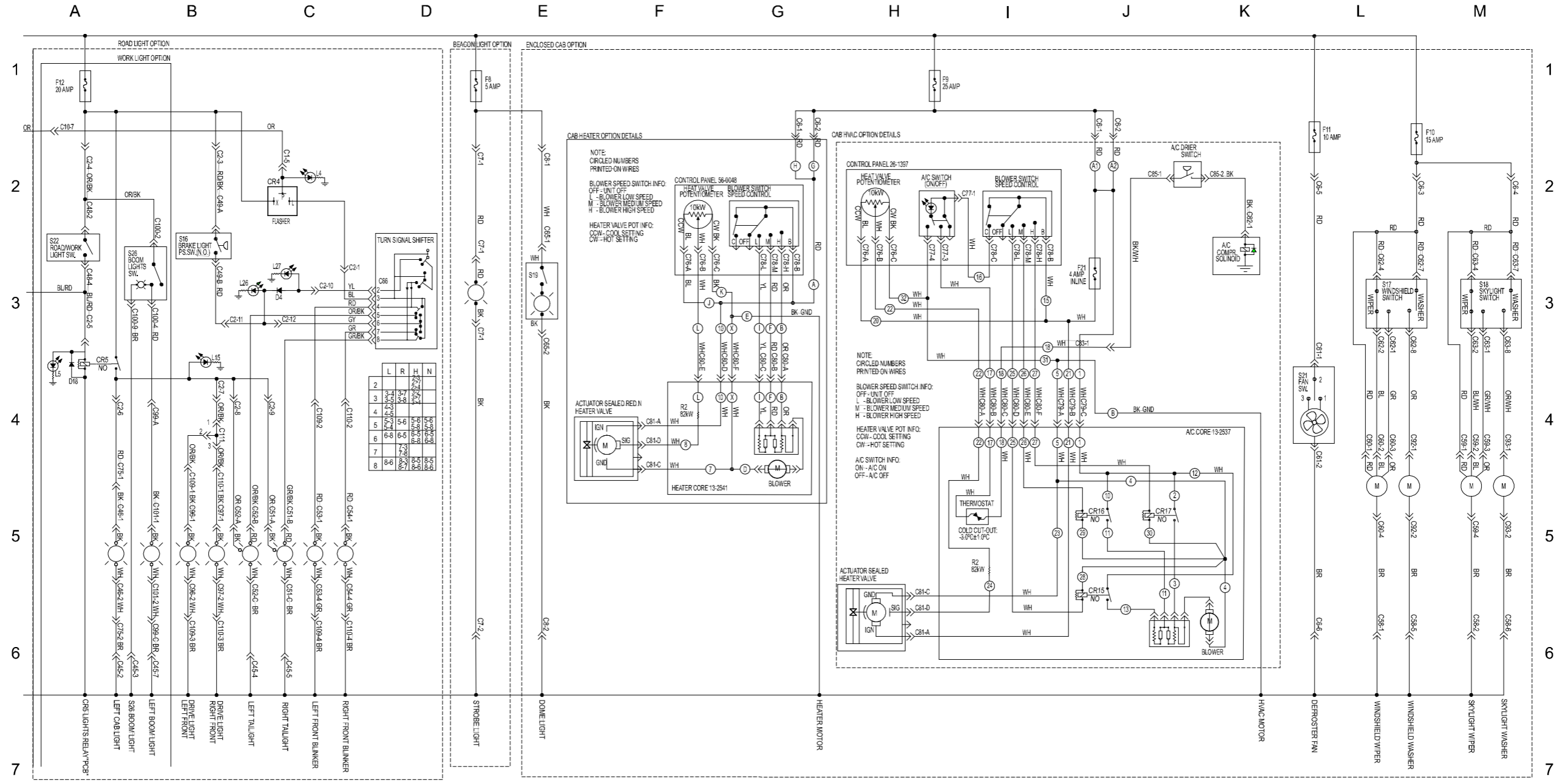

PCB - LOCATION PCB
 PM - LOCATION PRIMARY MANIFOLD
 SM - LOCATION SECONDARY MANIFOLD
 TM - LOCATION TRANSMISSION

Electrical Schematic
(from GTH08E-11500 to 13228)

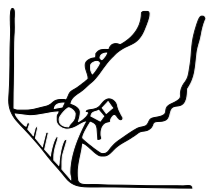

Electrical Schematic
(from GTH08E-13229)

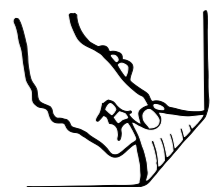

Electrical Schematic (from GTH08E-13229)

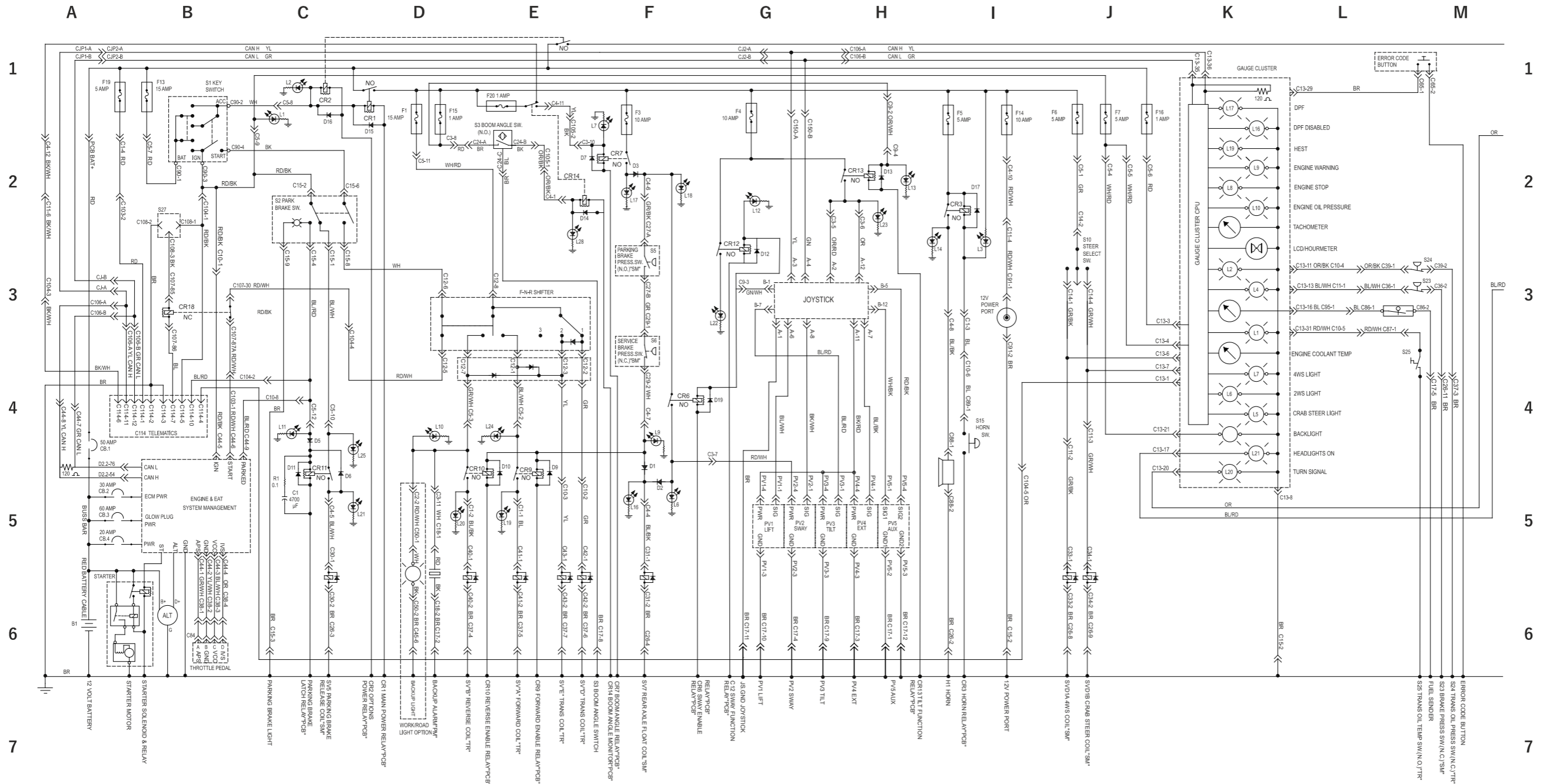

ES0602 E

Electrical Schematic (from GTH08E-13229)

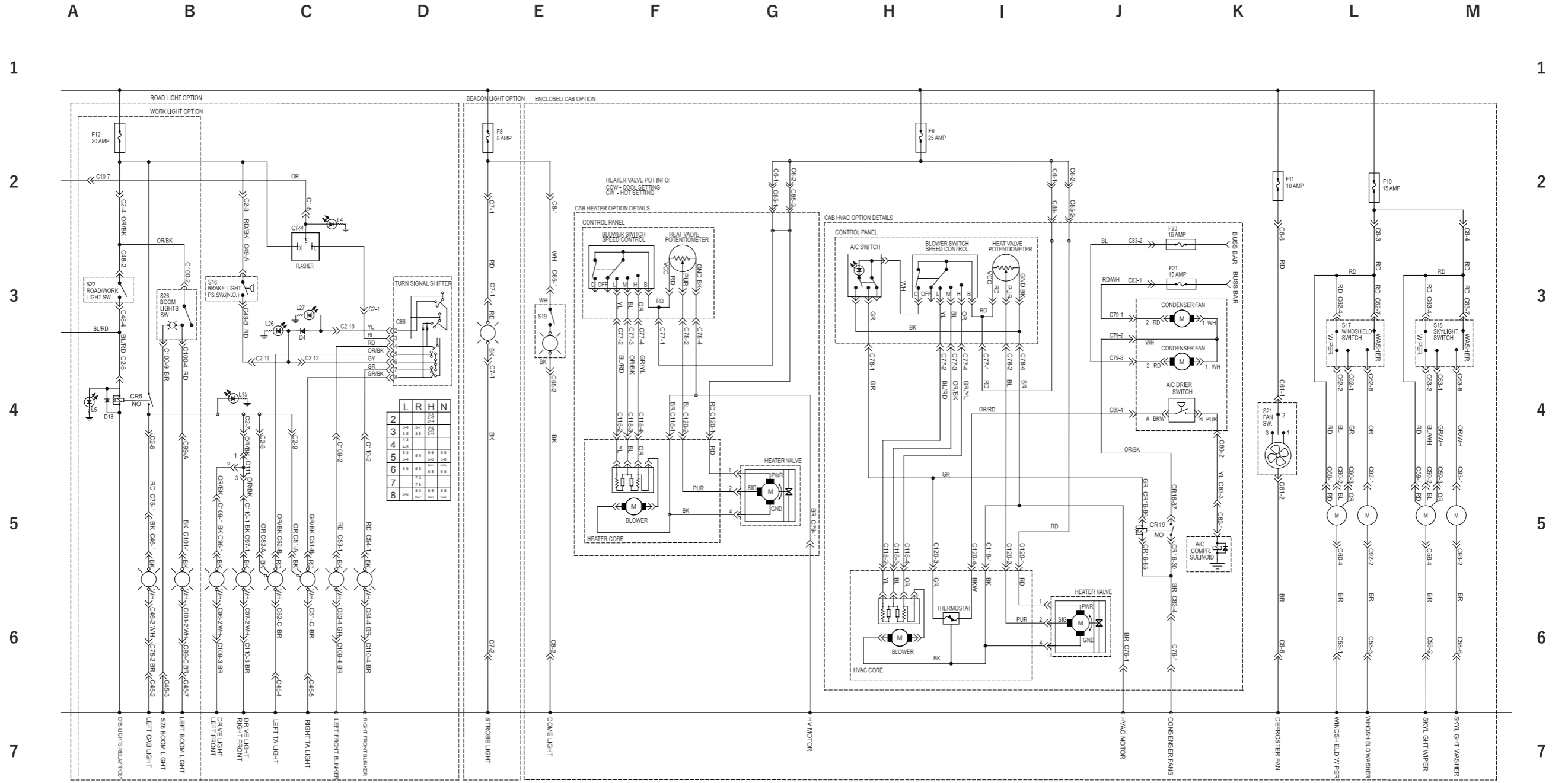

ES0602 E

Electrical Schematic
(from GTH08E-13229)

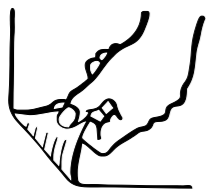

Electrical Schematic
(from GTH08E-13229)

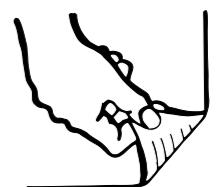

Electrical Schematic
(from GTH08E-13229)

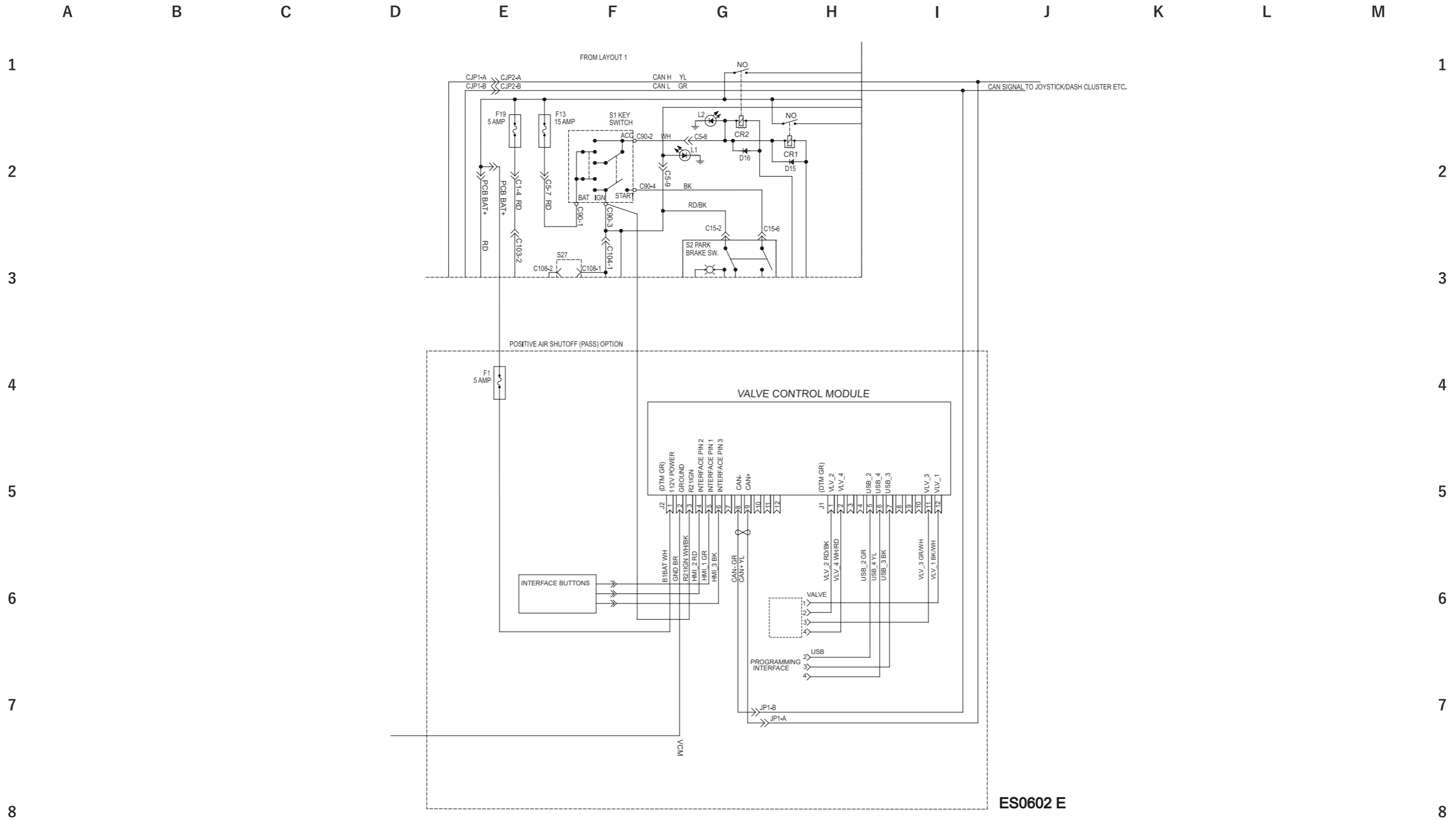

Electrical Schematic - Deutz T3 Eng Harness

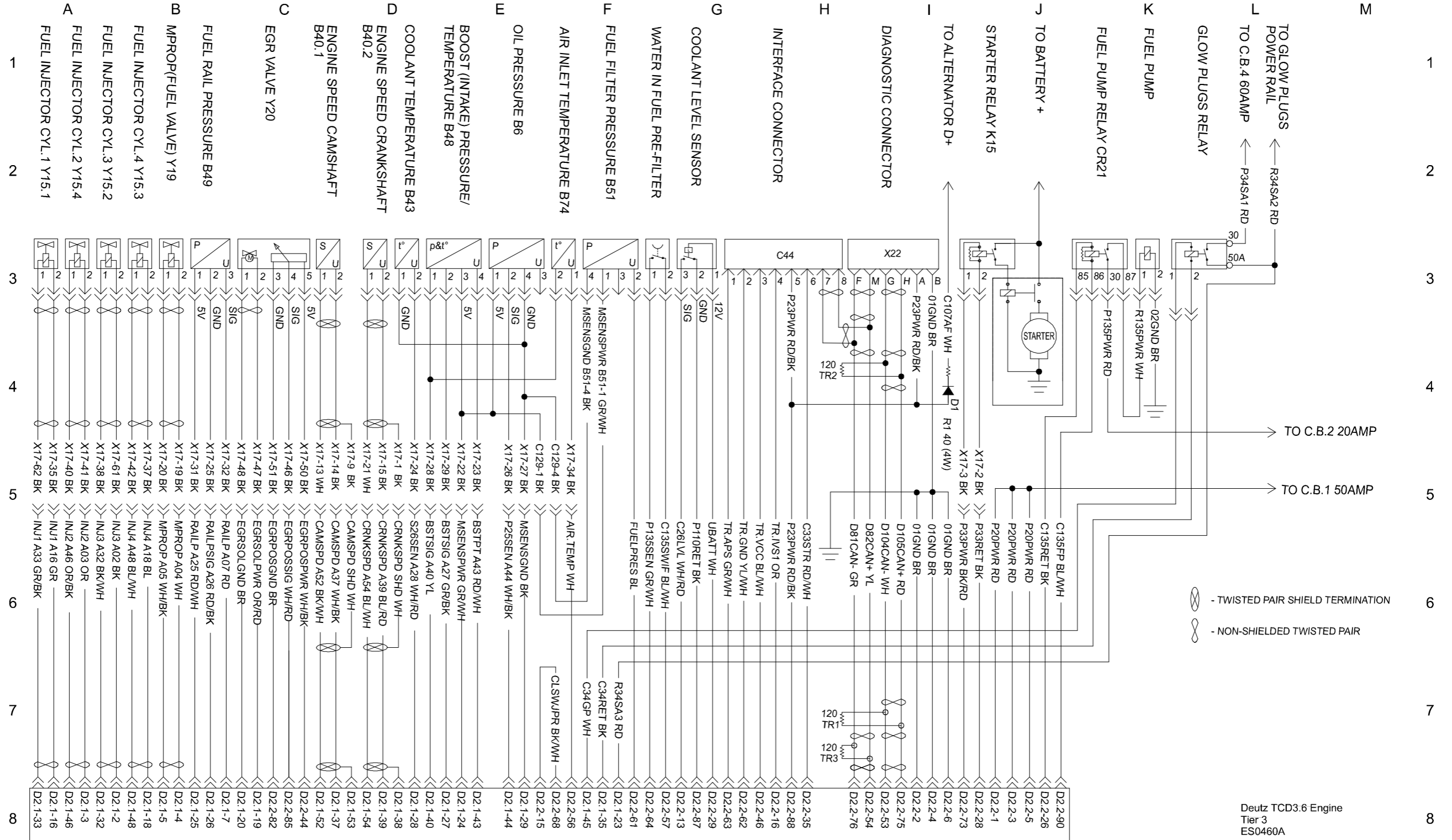

Deutz TCD3.6 Engine
 Tier 3
 ES0460A

Electrical Schematic - Deutz T3 Eng Harness

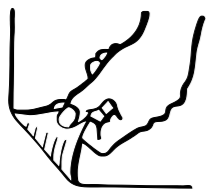

Electrical Schematic - Deutz T4F Eng Harness

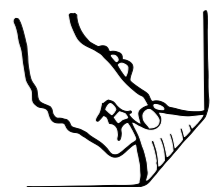

Electrical Schematic - Deutz T4F Eng Harness

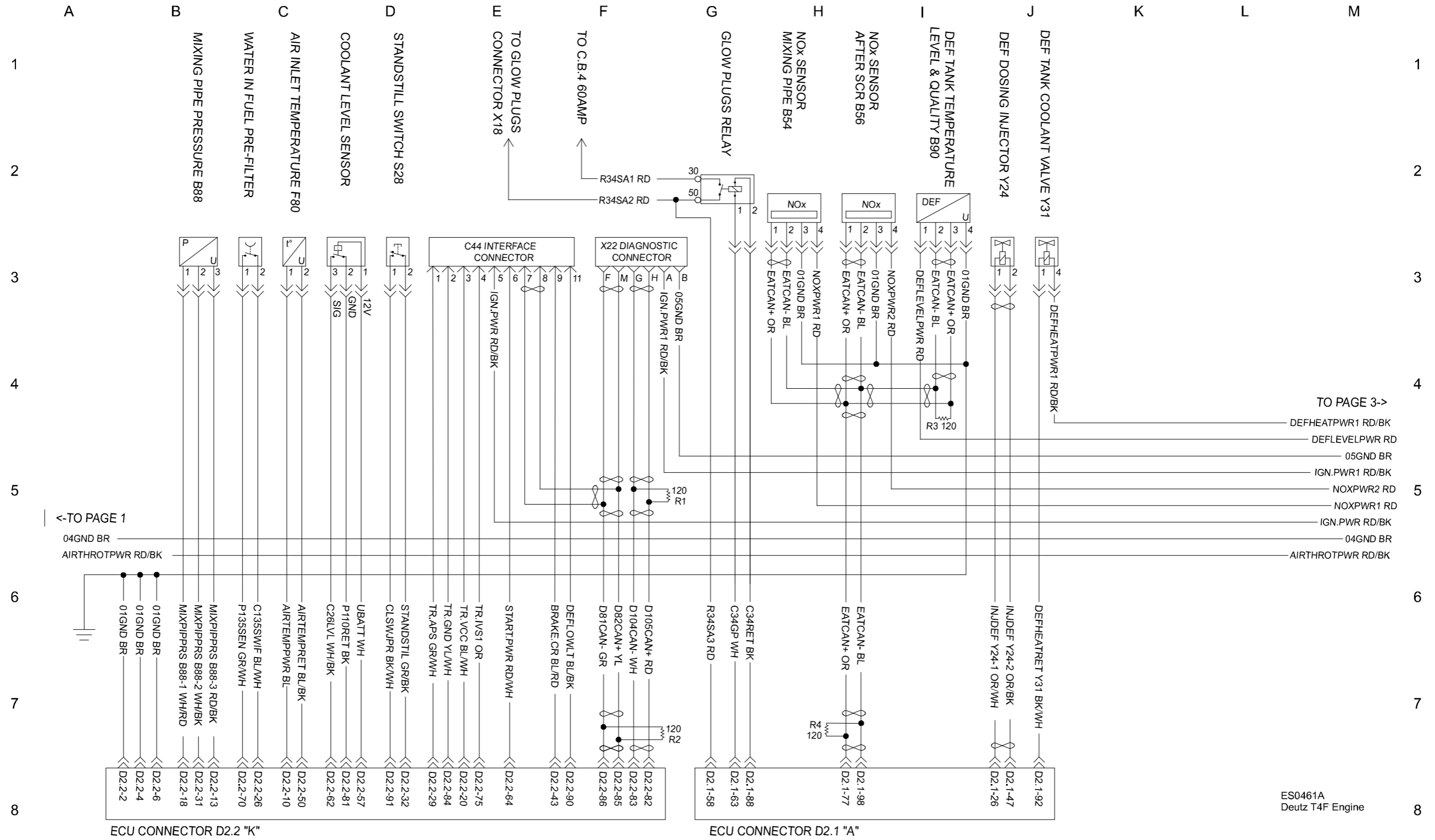

TO PAGE 3->

<-TO PAGE 1

ES0461A
Deutz T4F Engine

Electrical Schematic - Deutz T4F Eng Harness

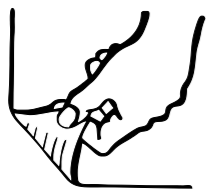

Electrical Schematic - Deutz T4F Eng Harness

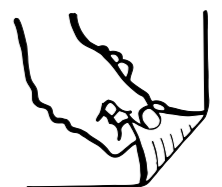

Electrical Schematic - Deutz T4F Eng Harness

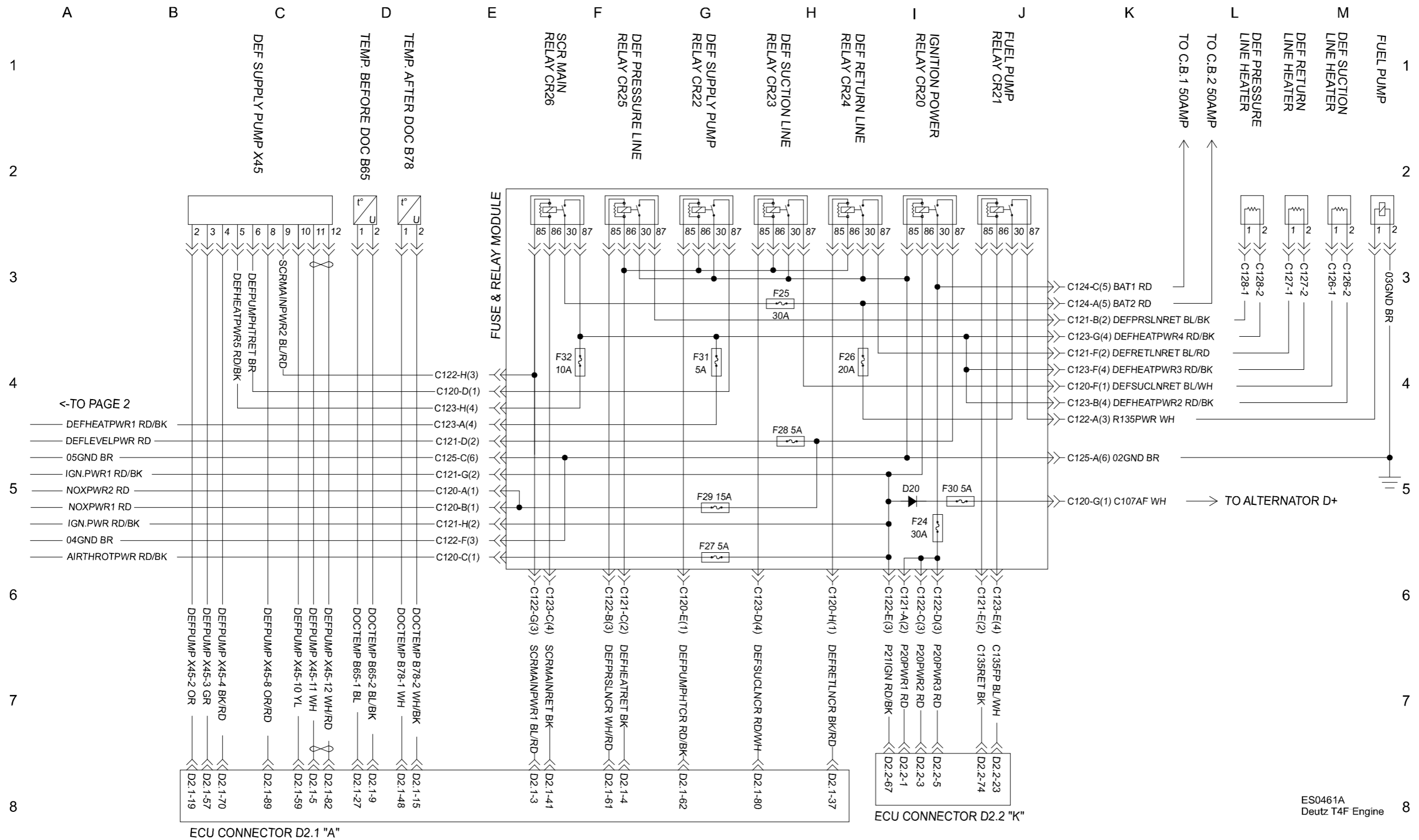

ES0461A
Deutz T4F Engine

Hydraulic Schematic
(from GTH08E-11500 to 13228)

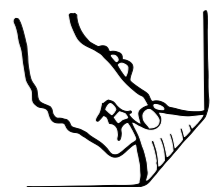

Hydraulic Schematic

(from GTH08E-11500 to 13228)

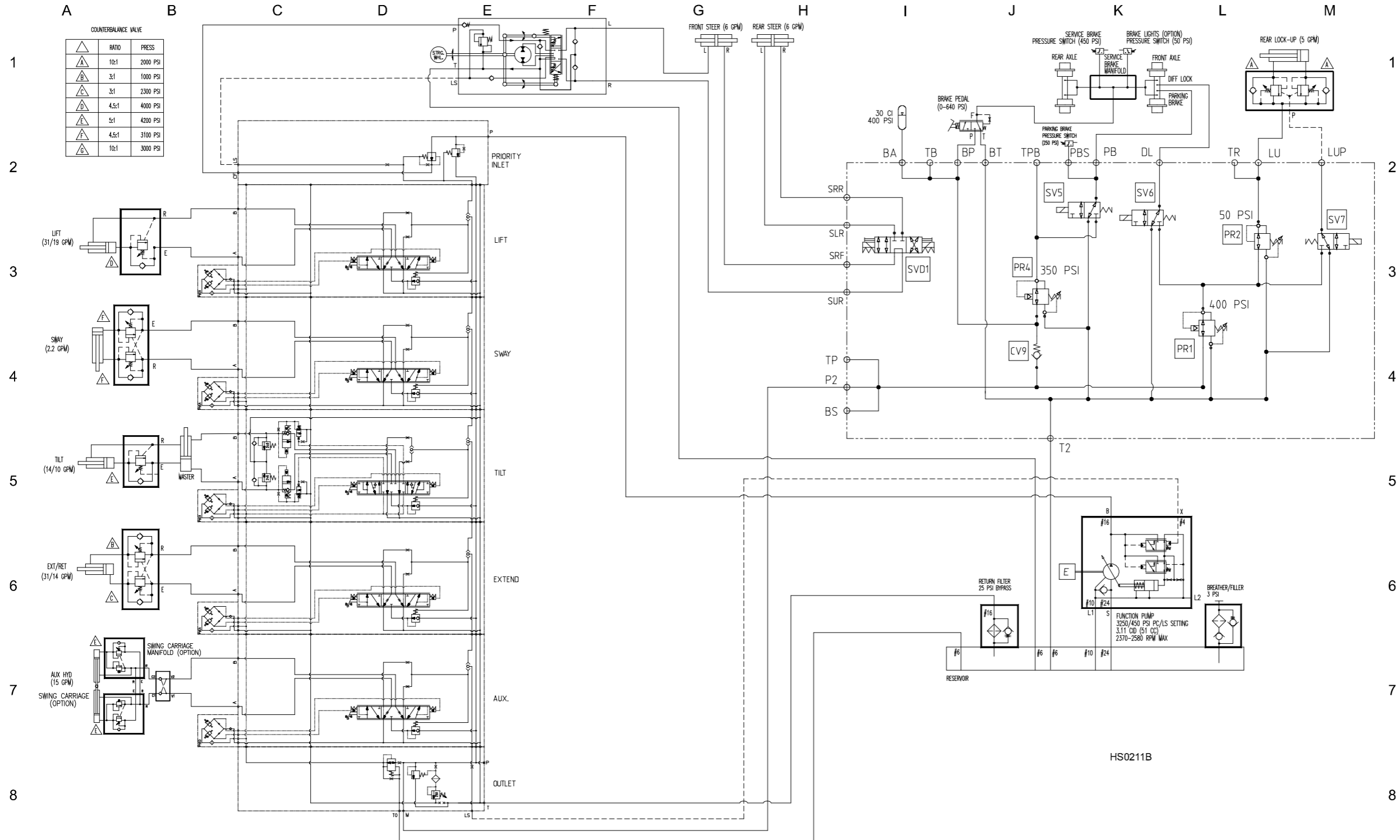

Hydraulic Schematic (from GTH08E-13229)

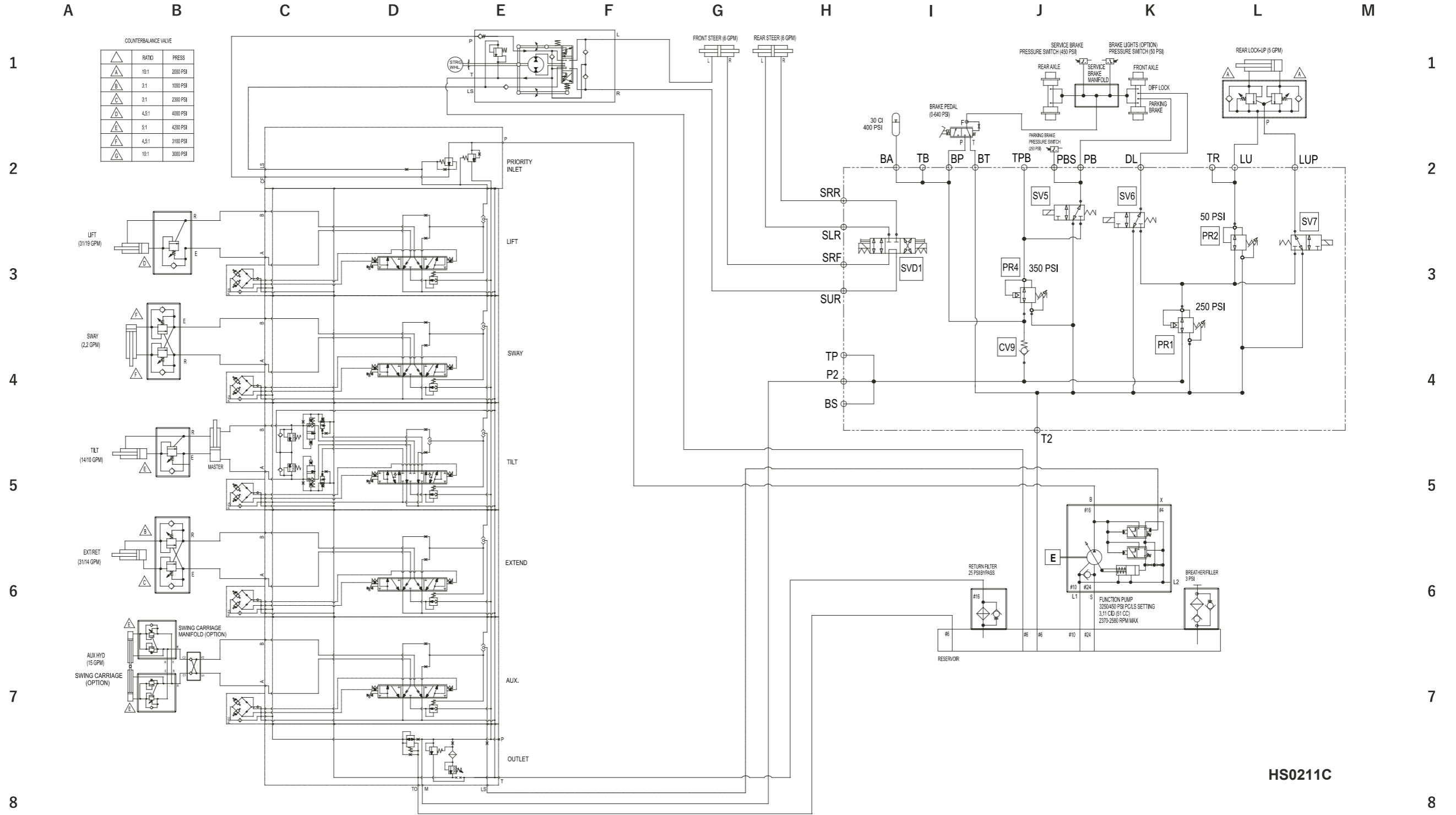

HS0211C

Hydraulic Schematic

(from GTH08E-13229)

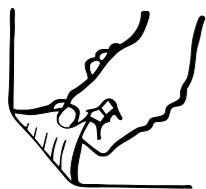

California Proposition 65



Operating, servicing and maintaining this equipment can expose you to chemicals including engine exhaust, carbon monoxide, phthalates, and lead, which are known to the State of California to cause cancer and birth defects or other reproductive harm. These chemicals can be emitted from or contained in other various parts and systems, fluids and some component wear by-products. To minimize exposure, avoid breathing exhaust, do not idle the engine except as necessary, service your equipment and vehicle in a well-ventilated area and wear gloves or wash your hands frequently when servicing your equipment or vehicle and after operation. For more information go to www.P65Warnings.ca.gov/passenger-vehicle.

Breathing diesel engine exhaust exposes you to chemicals known to the State of California to cause cancer and birth defects or other reproductive harm.

- Always start and operate the engine in a well-ventilated area.
- If in an enclosed area, vent the exhaust to the outside.
- Do not modify or tamper with the exhaust system.
- Do not idle the engine except as necessary.

For more information go to www.P65warnings.ca.gov/diesel.