

SKYTRAK[®]

Illustrated Parts Manual Service and Maintenance Manual

***Model
8042
10042
10054***

8990187

April 06, 2015

ANSI



JLG[®]

TABLE OF CONTENTS

SECTION 1 - MAIN FRAME AND GUARDS	7
FIGURE 1-1. MAIN FRAME	8
FIGURE 1-2. HOODS AND GUARDS	10
SECTION 2 - OPERATOR'S CAB AND CONTROLS	13
FIGURE 2-1. OPERATOR'S CAB - OPEN	14
FIGURE 2-2. OPERATOR'S CAB - CLOSED (OPTIONAL)	16
FIGURE 2-3. CAB DOOR	20
FIGURE 2-4. OPERATOR'S SEAT	22
FIGURE 2-5. CONTROL CONSOLE	24
FIGURE 2-6. TRANSMISSION SHIFT CONTROLS (Prior to SN 9909)	26
FIGURE 2-7. TRANSMISSION SHIFT CONTROLS (SN 9909 through 13197)	28
FIGURE 2-8. BOOM RAISE/LOWER AND EXTEND/RETRACT CONTROL	30
FIGURE 2-9. FRAME LEVEL AND ATTACHMENT TILT CONTROL	32
FIGURE 2-10. THROTTLE PEDAL CONTROL	34
FIGURE 2-11. SERVICE BRAKE PEDAL CONTROL	36
FIGURE 2-12. FRONT WINDSHIELD WIPER	38
FIGURE 2-13. CAB HEATER (OPTIONAL)	40
FIGURE 2-14. AUX. HYDRAULIC CONTROL (OPTIONAL)	42
FIGURE 2-15. MIRRORS	44
FIGURE 2-16. SKYLIGHT WINDSHIELD WIPER (OPTIONAL)	46
FIGURE 2-17. SOFT CAB ENCLOSURE (OPTIONAL)	48
SECTION 3 - DRIVE TRAIN	51
FIGURE 3-1. CONVERTER AND TRANSMISSION HOUSINGS (Prior to SN 9909)	52
FIGURE 3-2. CONVERTER GROUP (Prior to SN 9909)	56
FIGURE 3-3. FORWARD, REVERSE, LOW AND 2ND (Prior to SN 9909)	60
FIGURE 3-4. OUTPUT, IDLER AND THIRD (Prior to SN 9909)	62
FIGURE 3-5. TRANSMISSION CLUTCH GROUPS (Prior to SN 9909)	64
FIGURE 3-6. CONTROL VALVE ASSEMBLY (Prior to SN 9909)	66
FIGURE 3-7. EMERGENCY BRAKE (Prior to SN 9909)	68
FIGURE 3-8. TRANSMISSION MOUNTING (Prior to SN 9909)	70
FIGURE 3-9. ENGINE CONNECT (SN 9909 through 13197)	72
FIGURE 3-10. CONVERTER AND LAYSHAFT (SN 9909 through 13197)	74
FIGURE 3-11. OIL PRESSURE PUMP (SN 9909 through 13197)	76
FIGURE 3-12. INPUT SHAFT (SN 9909 through 13197)	78
FIGURE 3-13. GEARBOX HOUSING (SN 9909 through 13197)	80
FIGURE 3-14. CLUTCH PACK 1ST GEAR - 1 OF 2 (SN 9909 through 13197)	82
FIGURE 3-15. CLUTCH PACK 1ST GEAR - 2 OF 2 (SN 9909 through 13197)	86
FIGURE 3-16. CLUTCH PACK 2ND GEAR - 1 OF 2 (SN 9909 through 13197)	90
FIGURE 3-17. CLUTCH PACK 2ND GEAR - 2 OF 2 (SN 9909 through 13197)	94
FIGURE 3-18. CLUTCH PACK 3RD GEAR - 1 OF 2 (SN 9909 through 13197)	96
FIGURE 3-19. CLUTCH PACK 3RD GEAR - 2 OF 2 (SN 9909 through 13197)	100
FIGURE 3-20. OUTPUT SHAFT (SN 9909 through 13197)	104
FIGURE 3-21. PARKING BRAKE (SN 9909 through 13197)	106
FIGURE 3-22. POWER TAKE-OFF SHAFT (SN 9909 through 13197)	108
FIGURE 3-23. GEARSHIFT SYSTEM (SN 9909 through 13197)	110
FIGURE 3-24. CONTROL VALVE (SN 9909 through 13197)	112
FIGURE 3-25. TRANSMISSION FILTER AND DIPSTICK (SN 9909 through 13197)	116
FIGURE 3-26. OIL TUBES (SN 9909 through 13197)	118
FIGURE 3-27. TRANSMISSION MOUNTING (SN 9909 through 13197)	120
FIGURE 3-28. DRIVE SHAFT - ENGINE TO TRANSMISSION (Prior to SN 9909)	122
FIGURE 3-29. DRIVE SHAFT - ENGINE TO TRANSMISSION (SN 9909 through 13197)	124
FIGURE 3-30. DRIVE SHAFT - FRONT AND REAR (Prior to SN 9909)	126
FIGURE 3-31. DRIVE SHAFT - FRONT AND REAR (SN 9909 through 13197)	128
FIGURE 3-32. DIFFERENTIAL CARRIER ASSEMBLY	130
FIGURE 3-33. AXLE STEERING JOINTS	134
FIGURE 3-34. AXLE WHEEL ENDS (Prior to SN 0461)	136
FIGURE 3-35. AXLE WHEEL ENDS (SN 0461 through 13197)	140
FIGURE 3-36. TIE ROD AND STEERING CYLINDER MOUNTING	144
FIGURE 3-37. WHEELS AND TIRES - 8042	146
FIGURE 3-38. WHEELS AND TIRES - 10042/10054	150

TABLE OF CONTENTS

SECTION 4 - POWER PLANT.....	153
FIGURE 4-1. ENGINE, RADIATOR AND OIL COOLER MOUNTING (Prior to SN 0119).....	154
FIGURE 4-2. ENGINE, RADIATOR AND OIL COOLER MOUNTING (SN 0119 through 1598)	158
FIGURE 4-3. ENGINE, RADIATOR AND OIL COOLER MOUNTING (EPA) (SN 1599 through 13197).....	162
FIGURE 4-4. TORSION COUPLER (SN 9909 through 13197).....	166
FIGURE 4-5. EXHAUST SYSTEM.....	168
FIGURE 4-6. AIR CLEANER.....	170
FIGURE 4-7. FUEL SYSTEM (Prior to SN 1599).....	172
FIGURE 4-8. FUEL SYSTEM (EPA) (SN 1599 through 13197).....	174
SECTION 5 - HYDRAULIC CIRCUITS	177
FIGURE 5-1. POWER STEERING CIRCUIT (Prior to SN 9909)	178
FIGURE 5-2. POWER STEERING CIRCUIT (SN 9909 through 13197).....	180
FIGURE 5-3. CONTROL VALVES CIRCUIT (Prior to SN 9909).....	182
FIGURE 5-4. CONTROL VALVES CIRCUIT (SN 9909 through 13197)	184
FIGURE 5-5. BOOM RAISE/LOWER AND EXTEND/RETRACT CIRCUIT (Prior to SN 9909).....	186
FIGURE 5-6. BOOM RAISE/LOWER AND EXTEND/RETRACT CIRCUIT (SN 9909 through 13197)	188
FIGURE 5-7. ATTACHMENT TILT AND SLAVE CIRCUIT	190
FIGURE 5-8. FRAME TILT AND STABILIZER CIRCUIT	192
FIGURE 5-9. SERVICE BRAKE AND DE-CLUTCH CIRCUIT	194
FIGURE 5-10. VALVE PLATE ASSEMBLY (WITHOUT OUTRIGGERS 8042 ONLY).....	196
FIGURE 5-11. VALVE PLATE ASSEMBLY (WITH OUTRIGGERS 10042/10054 ONLY)	198
FIGURE 5-12. TRANSMISSION COOLING CIRCUIT (Prior to SN 9909).....	202
FIGURE 5-13. TRANSMISSION COOLING CIRCUIT (SN 9909 through 13197)	204
FIGURE 5-14. AUXILIARY HYDRAULIC CIRCUIT (OPTIONAL)	206
FIGURE 5-15. OUTRIGGER HYDRAULIC CIRCUIT (10042/10054 ONLY).....	208
SECTION 6 - HYDRAULIC COMPONENTS	211
FIGURE 6-1. HYDRAULIC RESERVOIR.....	212
FIGURE 6-2. MAIN PUMP (Prior to SN 9909)	214
FIGURE 6-3. MAIN PUMP (SN 9909 through 13197).....	218
FIGURE 6-4. BOOM EXTEND CYLINDER (EARLY PRODUCTION).....	222
FIGURE 6-5. BOOM EXTEND CYLINDER (CURRENT PRODUCTION)	224
FIGURE 6-6. BOOM HOIST CYLINDER (Prior to SN 5819).....	226
FIGURE 6-7. BOOM HOIST CYLINDER (SN 5819 through 13197)	228
FIGURE 6-8. FRAME TILT CYLINDER.....	230
FIGURE 6-9. STABILIZER CYLINDER.....	232
FIGURE 6-10. SLAVE CYLINDER (EARLY PRODUCTION).....	234
FIGURE 6-11. SLAVE CYLINDER (CURRENT PRODUCTION)	236
FIGURE 6-12. ATTACHMENT TILT CYLINDER.....	238
FIGURE 6-13. OUTRIGGER CYLINDER (Prior to SN 10882)	240
FIGURE 6-14. OUTRIGGER CYLINDER (SN 10882 through 13197).....	242
FIGURE 6-15. SWING CARRIAGE CYLINDER.....	244
FIGURE 6-16. SIDE TILT CARRIAGE CYLINDER	246
FIGURE 6-17. STEERING CYLINDER (Prior to SN 1168)	248
FIGURE 6-18. STEERING CYLINDER (SN 1168 through 13197).....	250
FIGURE 6-19. MAIN CONTROL VALVE.....	252
FIGURE 6-20. SECONDARY CONTROL VALVE.....	254
FIGURE 6-21. DIRECTIONAL CONTROL VALVES 1 OF 2	258
FIGURE 6-22. DIRECTIONAL CONTROL VALVES 2 OF 2	260
SECTION 7 - ELECTRICAL.....	263
FIGURE 7-1. ELECTRICAL SYSTEM - CAB HARNESS (Prior to SN 0292).....	264
FIGURE 7-2. ELECTRICAL SYSTEM - CAB HARNESS (SN 0292 through 9908).....	266
FIGURE 7-3. ELECTRICAL SYSTEM - CAB HARNESS (SN 9909 through 13197).....	268
FIGURE 7-4. ELECTRICAL SYSTEM - ENGINE HARNESS (8042 Prior to SN 0207; 10042 Prior to SN 0212).....	270
FIGURE 7-5. ELECTRICAL SYSTEM - ENGINE HARNESS (8042 SN 0207 through 1598; 10042 SN 0212 through 1598; 10054 Prior to SN 1599).....	272
FIGURE 7-6. ELECTRICAL SYSTEM - ENGINE HARNESS (8042 SN 1599 through 5234; 10042 SN 1599 through 5250; 10054 SN 1599 through 5274).....	274
FIGURE 7-7. ELECTRICAL SYSTEM - ENGINE HARNESS (EPA) (8042 Prior to SN 5236; 10042 Prior to SN 5252; 10054 SN 5275 through 9908).....	276
FIGURE 7-8. ELECTRICAL SYSTEM - ENGINE HARNESS (EPA) (SN 9909 through 13197).....	278

TABLE OF CONTENTS

FIGURE 7-9. LIGHTING SYSTEM	280
FIGURE 7-10. OUTRIGGER ELECTRICAL HARNESS (10042/10054 ONLY)	282
SECTION 8 - DECALS AND PAINT	285
FIGURE 8-1. DECALS AND PAINT	286
SECTION 9 - BOOM AND ATTACHMENTS	289
FIGURE 9-1. OUTER BOOM	290
FIGURE 9-2. INTERMEDIATE BOOM - 8042 & 10042	292
FIGURE 9-3. INNER BOOM - 8042 & 10042	296
FIGURE 9-4. QUICK ATTACH	302
FIGURE 9-5. CARRIAGE 48IN	304
FIGURE 9-6. CARRIAGE 60IN	306
FIGURE 9-7. CARRIAGE 72IN	308
FIGURE 9-8. SIDE TILT CARRIAGE - EARLY PRODUCTION (OPTIONAL)	310
FIGURE 9-9. SIDE TILT CARRIAGE - CURRENT PRODUCTION (OPTIONAL)	312
FIGURE 9-10. OUTRIGGERS (10042/10054 ONLY)	314
FIGURE 9-11. SWING CARRIAGE (OPTIONAL)	316
FIGURE 9-12. SHEET MATERIAL HANDLER (OPTIONAL)	318
FIGURE 9-13. UTILITY BUCKET (OPTIONAL)	320
FIGURE 9-14. PRIMARY INTERMEDIATE BOOM - 10054	322
FIGURE 9-15. SECONDARY INTERMEDIATE BOOM - 10054	326
FIGURE 9-16. INNER BOOM - 10054	328
FIGURE 9-17. BOOM EXTEND CHAINS - 8042 & 10042	330
FIGURE 9-18. BOOM RETRACT CHAIN - 8042 & 10042 (Prior to SN 1085)	332
FIGURE 9-19. BOOM RETRACT CHAIN - 8042 & 10042 (SN 1085 through 13197)	334
FIGURE 9-20. BOOM EXTEND CHAINS - 10054	336
FIGURE 9-21. BOOM RETRACT CHAINS - 10054 (Prior to SN 0885)	338
FIGURE 9-22. BOOM RETRACT CHAINS - 10054 (SN 0885 through 1084)	340
FIGURE 9-23. BOOM RETRACT CHAINS - 10054 (SN 1085 through 13197)	342
FIGURE 9-24. TRUSS BOOM 12 & 15 FT (OPTIONAL)	344
PART NUMBER INDEX	347

SECTION 1 - MAIN FRAME AND GUARDS

SECTION 1 - MAIN FRAME AND GUARDS

SECTION 1 - MAIN FRAME AND GUARDS

FIGURE 1-1. MAIN FRAME

Locate the fracture in bearing outer race at the clock position shown for each application (Items 5 & 7).

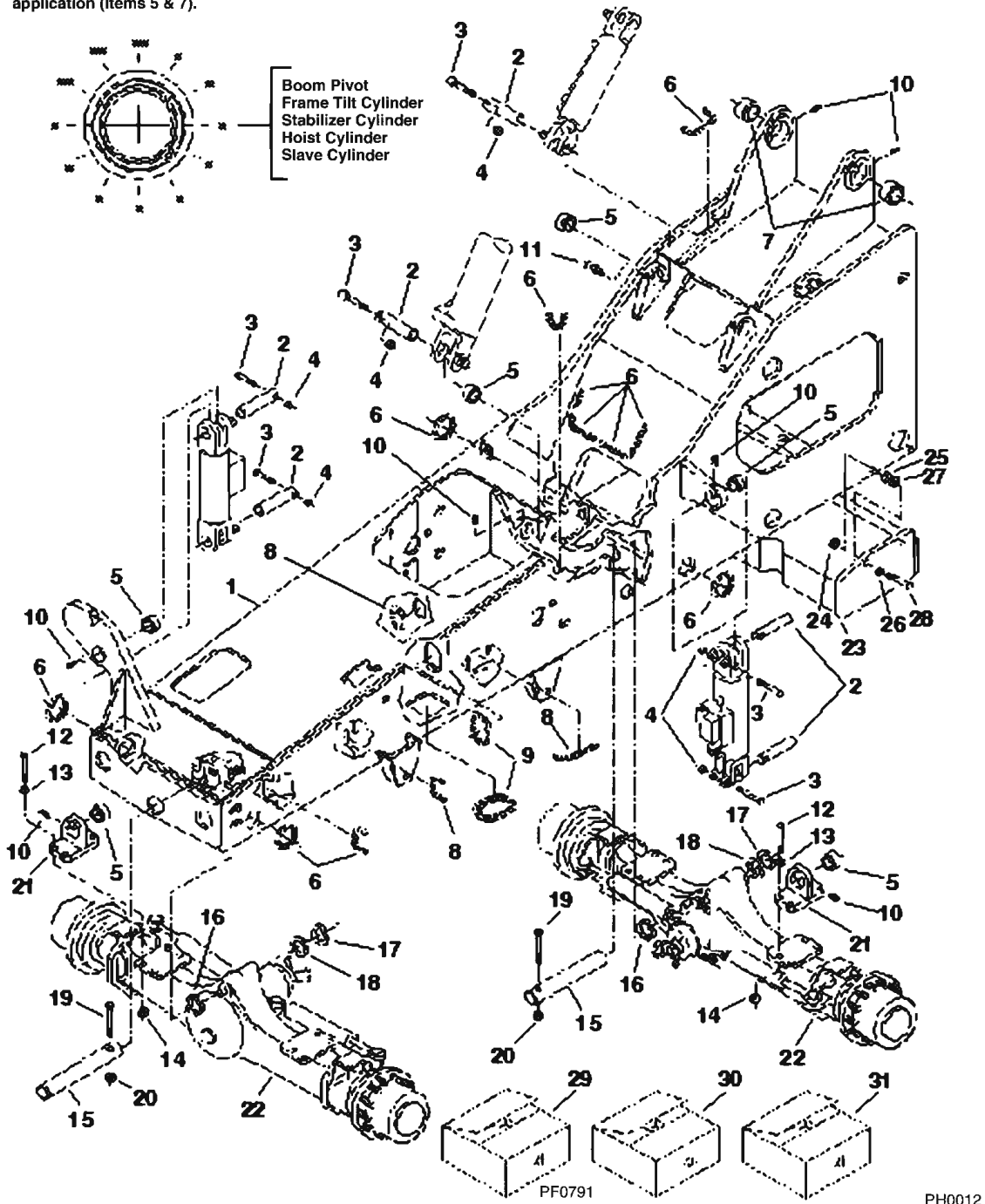

SECTION 1 - MAIN FRAME AND GUARDS

FIGURE 1-1. MAIN FRAME

ITEM	PART NUMBER	QTY	DESCRIPTION	REV
1	Consult Factory	1	Weldment, Frame	
2	7092292	8	Pin, Hoist, Slave, Tilt, and Stabilizer Cylinders	
3	8303782	8	HHCS, 1/2-13 x 4in	
4	8305644	8	Nut, Hex Lock Elastic 1/2-13	
5	8065640	8	Bearing, 2in I.D.	
6	6620531	AR	Conduit, 1 x 5ft - Cut to Fit	
7	8065641	2	Bearing, 2-3/4 I.D.	
8	7124331	AR	Conduit, 1/2 x 5ft - Cut to Fit	
9	7125861	AR	Conduit, 3/4 x 5ft - Cut to Fit	
10	8520013	8	Fitting, Grease	
11	8520021	2	Fitting, Grease 90	
12	8303724	8	HHCS, 3/4-10 x 3-1/2in	
13	8310111	8	Washer, Flat .81 x 2 x .15in	
14	8310067	8	Nut, Hex Lock Elastic 3/4-10	
15	7079442	2	Pin, Axle Pivot	
16	8307913	AR	Spacer, Washer .12in Thick	
17	8307912	AR	Spacer, Washer .06in Thick	
18	8310259	AR	Spacer, Washer .09in Thick	
19	8303655	2	HHCS, 5/8-11 x 4-1/2in	
20	8305643	2	Nut, Hex Lock Elastic 5/8-11	
21	7099312	2	Anchor, Cylinder	
22	8040258	2	Axle	
23	7098563	1	Counterweight	
24	8305021	4	Nut, Hex 1in-8	
25	5724302	2	Washer, Shim .06in Thick	
26	8307012	4	Washer, Lock 1in	
27	8310066	2	Washer, Flat .134in Thick	
28	8310051	4	HHCS, 1-8 x 4in	
		Ref	KITS	
29	7138302	1	Kit, Cylinder Anchor (Includes 1 of Item 5, 1 of Item 10 & 1 of Item 21)	
30	7129313	1	Kit, Hoist Cylinder Pivot Left Side (Includes 1 of Item 2, 1 of Item 5 & 1 of Item 10)	
31	7129323	1	Kit, Hoist Cylinder Pivot Right Side (Includes 1 of Item 2, 1 of Item 5 & 1 of Item 10)	

SECTION 1 - MAIN FRAME AND GUARDS

FIGURE 1-2. HOODS AND GUARDS

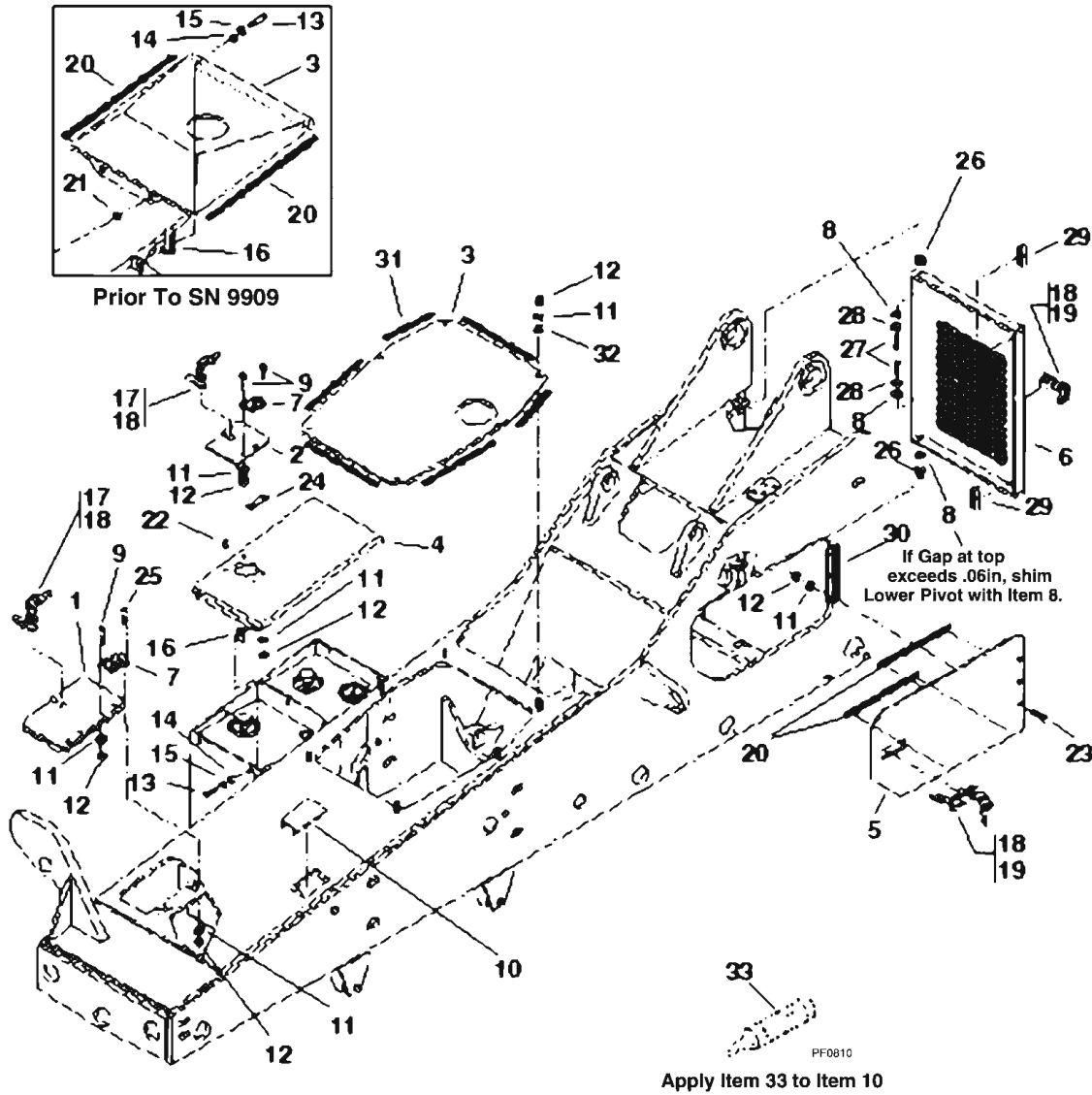

PH1330

SECTION 1 - MAIN FRAME AND GUARDS

FIGURE 1-2. HOODS AND GUARDS

ITEM	PART NUMBER	QTY	DESCRIPTION	REV
1	7098262	1	Cover, Tool Box	
2	7084792	1	Cover, Fuel Tank	
3	7111164	1	Cover, Transmission (Prior to SN 9909)	
3	7150393	1	Cover, Transmission (SN 9909 to Present)	
4	NLA	1	Cover, Fuel/Hydraulic Tank, For Service, Order P/N 7138614 (Prior to SN 11021)	
4	7138614	1	Cover, Fuel/Hydraulic Tank (SN 11021 to Present)	
5	7095452	2	Cover, Side Access	
6	7097174	1	Cover, Radiator	
7	8344010	3	Hinge	
8	8307110	AR	Washer, Flat 3/8in	
9	8303034	8	TRHDCS, 1/4-20 x 3/4in	
10	7111473	1	Cover	
11	8307002	18	Washer, Lock 1/4in	
12	8305004	18	Nut, Hex 1/4-20	
13	8303656	6	HHCS, 5/16-18 x 7/8in	
14	8307203	6	Washer, Flat 5/16in	
15	8307004	6	Washer, Lock 5/16in	
16	8305906	6	Nut, Retaining 5/16in	
17	8342807	2	Lock w/Key	
18	8342808	AR	Key Set	
19	8342416	3	Latch, w/Lock and Key	
20	8581007	4	Tape, Foam, 38in (sold in 50in increments)	
21	8580213	2	Grommet	
22	8582413	2	Plug, Bumper	
23	8303729	6	HHCS, 1/4-20 x 5/8in	
24	7084821	1	Shim	
25	8310136	4	TRHDCS, 1/4-20 x 1-1/4in	
26	7082311	2	Insert	
27	8304660	2	SHCS, 3/8-16 x 3/4in	
28	8307005	2	Washer, Lock 3/8in	
29	5724742	2	Gasket	
30	7094682	2	Hinge, Side Access Cover	
31	8581007	AR	Tape, Foam - 170in (Cut to Fit)	
32	8307202	6	Washer, Flat 1/4in	
33	8526035	AR	Caulk, Clear RTV-08	

SECTION 2 - OPERATOR'S CAB AND CONTROLS

SECTION 2 - OPERATOR'S CAB AND CONTROLS

SECTION 2 - OPERATOR'S CAB AND CONTROLS

FIGURE 2-1. OPERATOR'S CAB - OPEN

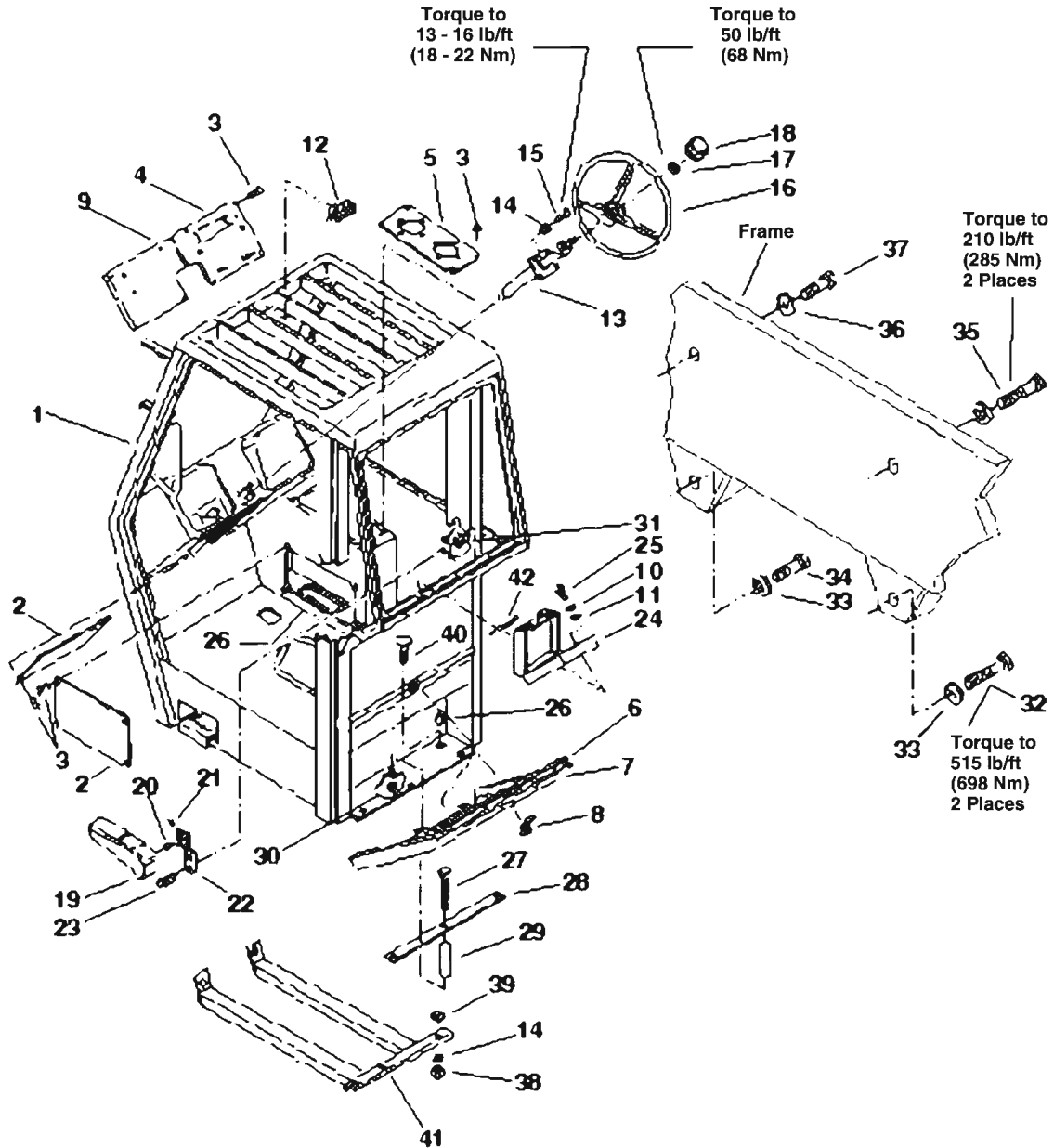

PH0532

SECTION 2 - OPERATOR'S CAB AND CONTROLS

FIGURE 2-1. OPERATOR'S CAB - OPEN

ITEM	PART NUMBER	QTY	DESCRIPTION	REV
1	7099742	1	Cab Assembly, Operator's Protective Structure Orange, Open - 10042/10054 (Right Rear Corner Post Reinforced)	
1	7112102	1	Cab Assembly, Operator's Protective Structure Orange, Open - 8042	
2	8033050	2	Panel, Lower	
3	8303034	20	THMS, Torx, 1/4-20 x 3/4in	
4	7302077	1	PANEL, SIDE CONSOLE	
5	8033053	1	Panel, Side Console	
6	8033031	1	Gasketing, Sponge Rubber, 25-1/4in	
7	8033022	1	Cover, Battery	
8	8342807	1	Lock, Cam	
9	8033051	1	Panel, Left Front Console (Prior to SN 9909)	
9	7150361	1	Panel, Left Front Console (SN 9909 to Present)	
10	8307002	3	Washer, Lock 1/4in	
11	8307109	3	Washer, Flat 1/4in	
12	8466306	1	Gauge, Tilt Angle	
13	8721023	1	Column, Steering (Prior to SN 9909)	
13	7150382	1	Column, Steering (SN 9909 to Present)	
14	8307005	8	Washer, Lock 3/8in	
15	8303534	4	FHCS, 3/8-16 x 1-1/4in	
16	8720014	1	Wheel, Steering	
17	8305916	1	Nut, Steering Column	
18	8720015	1	Cap, Steering Wheel	
19	8864038	1	Arm Rest	
20	8065639	1	Bushing, Sleeve	
21	8302147	1	Pin, Roll	
22	7098342	1	Bracket, Arm Rest	
23	8303705	2	Scr FLHDC 1/4-20 x 3/4in	
24	8990147	1	Holder, Manual	
25	8303729	2	HHCS, 1/4-20 x 5/8in	
26	7124331	1	Conduit, 1/2 I.D. x 5ft - Cut to Fit	
27	8310344	AR	Bolt, Carriage 3/8-16 x 10in	
28	7129261	1	Bar, Single Battery Hold Down (Current Production)	
28	7082971	1	Bar, Double Battery Hold Down (Early Production)	
29	7125521	AR	Hose, 3/8 x 8.0in	
30	8305645	2	Nut, Lock 3/8-16	
31	8305624	2	Nut, Lock 1/4-20	
32	8310050	1	HHCS, 1-8 x 6in	
33	8307012	2	Washer, Lock 1in	
34	8310049	1	HHCS, 1-8 x 2-3/4in	
35	8310112	1	HHCS, 3/4-10 x 6in	
36	8307010	2	Washer, Lock 3/4in	
37	8303638	1	HHCS, 3/4-10 x 2-3/4in	
38	8305008	4	Nut, Hex 3/8-16	
39	8310070	4	Retainer - 3/8in	
40	8310036	4	Bolt, Carriage 3/8-16 x 1-1/4in	
41	7097233	1	Guard, Bottom	
42	7125691	2	Rope Caulk, 0.2 Dia x 3.0in	

SECTION 2 - OPERATOR'S CAB AND CONTROLS

FIGURE 2-2. OPERATOR'S CAB - CLOSED (OPTIONAL)

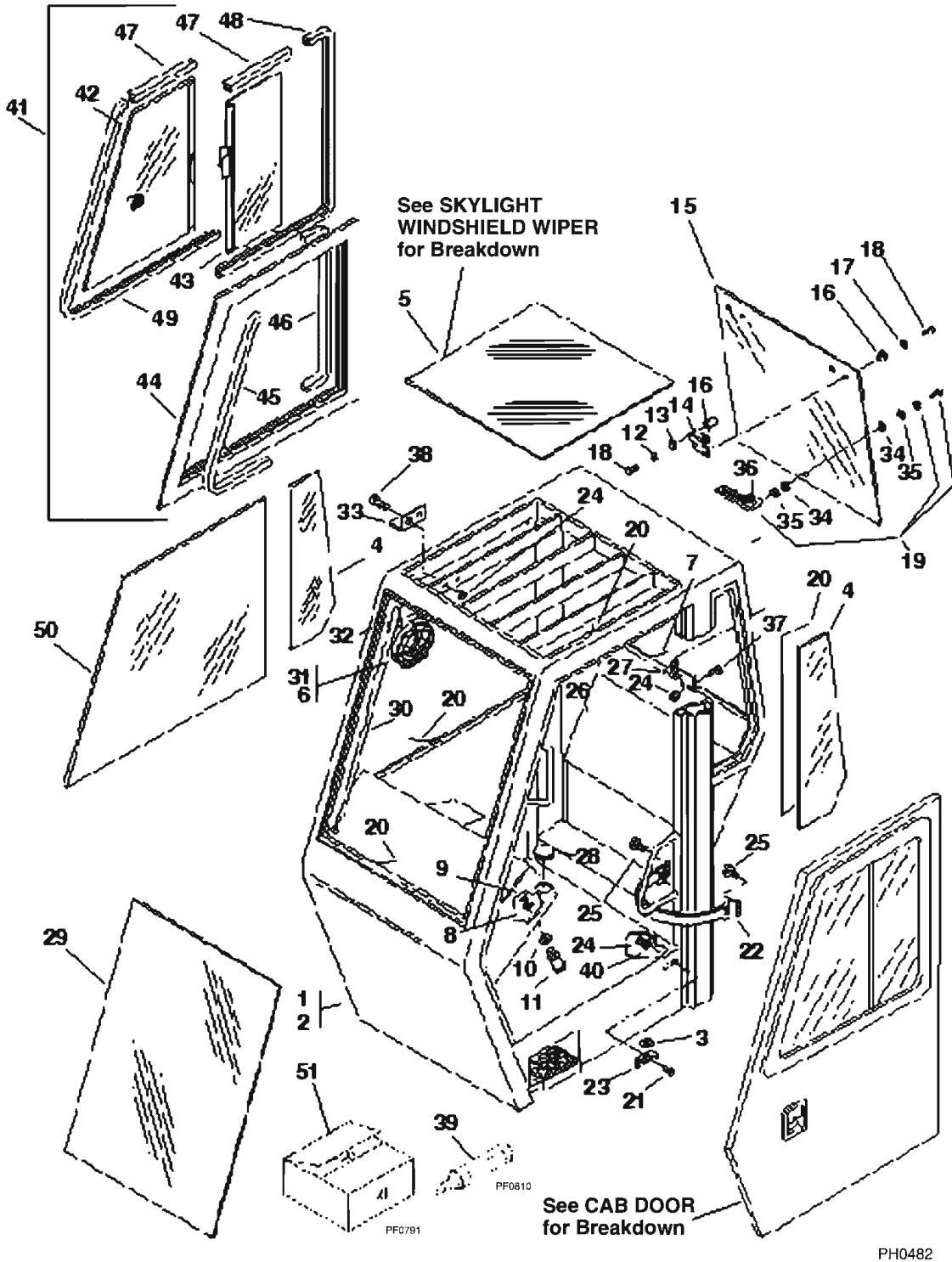

SECTION 2 - OPERATOR'S CAB AND CONTROLS

FIGURE 2-2. OPERATOR'S CAB - CLOSED (OPTIONAL)

ITEM	PART NUMBER	QTY	DESCRIPTION	REV
1	7112092	1	Cab, Enclosed - Complete (Includes Cab Door; 10042 & 10054 Reinforced, Orange)	
1	7099324	1	Cab, Enclosure Kit minus Cab Door (Includes Items 3 thru 49 on this page and all parts on FRONT WINDSHIELD WIPER AND CAB HEATER (Optional) for Breakdown)	
1	7127282	1	Cab Assembly, Operator's Protective Structure Enclosed Orange - Optional (Includes: 7099324 - Cab Enclosure Kit, 8346008 - Door Assembly, 7112102 - Cab Assembly, Operator's Protective Structure Orange, Open)	
2		Ref	Cab Assembly:See Operators Cab-Open	
3	8307207	1	Washer, Flat 5/8in	
4	8033079	2	Window, Wing	
5	8033081	1	Window, Skylight w/o Wiper Assembly	
6	8033092	4	HHCS, #10-24 x 3/4in	
7	8033072	1	Seal, Rubber, 120in	
8	8307113	1	Washer, Flat 7/16in	
9	8305647	1	Nut, Hex Lock 7/16-14	
10	8307206	AR	Washer, Flat 1/2in	
11	8346010	1	Bolt, Striker	
12	8307003	4	Washer, Lock #10	
13	8307201	4	Washer, Flat 3/16in	
14	8033085	2	Hinge, Spring	
15	8033084	1	Window, Rear	
16	8033086	8	Nut, Well	
17	8033087	4	Washer, Nylon	
18	8033088	8	Screw, Phil Hd, #10-32 x 3/4in	
19	8033044	1	Window Hold Slide Assembly, w/Hardware	
20	8585135	3	Tape, Butyl, 1/4in sq x 15ft Roll	
21	8303540	2	HHCS, 1/4-20 x 1in	
22	8342413	1	Strap	
23	8033090	1	Bracket, Door Mounting	
24	8305601	6	Nut, Hex Lock 1/4-20	
25	8303982	4	Screw, Self Tap 1/4-20 x 3/4in	
26	8346011	1	Panel, Rear Foam	
27	8585138	1	Weldment, Latch Bracket	
28	8580315	1	Plug, Hole	
29	8033479	1	Window, Front	
30	8033076	1	Wire Assembly, Fan	
31	8033078	1	Fan, Defroster	
32	8033077	2	Connector, Wire	
33	8033094	1	Bracket, Circulation Fan	
34	8585139	2	Washer, Flat Plastic 3/8in	
35	8307204	2	Washer, Flat 3/8in	
36	8580115	1	Knob	
37	8303776	2	HHCS, 1/4-20 x 1/2in	
38	8303540	2	HHCS, 1/4-20 x 1in	
39	8585134	AR	Sealant, Urethane, 10 oz Cartridge	
40	8307002	2	Washer, Lock 1/4in	
41	8346009	1	Window, Right Side Sliding (Includes Items 42 thru 49)	
42	8033833	1	Glass Assembly - Front	
43	8033834	1	Glass Assembly - Rear	

SECTION 2 - OPERATOR'S CAB AND CONTROLS

ITEM	PART NUMBER	QTY	DESCRIPTION	REV
44	8033835	1	Frame Assembly	
47	8034546	1	Rubber, Flkd	
46	8033837	1	Trim, Stop - Rear	
47	8033838	2	Rubber, Flkd	
48	8033839	1	Rubber, Flkd	
49	8033840	1	Rubber, Flkd	
50	8033082	1	Window, Right Side (Optional)	
51	8585133	1	Window Glue Kit (Includes Items 20, 39, four setting blocks and installation instructions)	

SECTION 2 - OPERATOR'S CAB AND CONTROLS

FIGURE 2-3. CAB DOOR

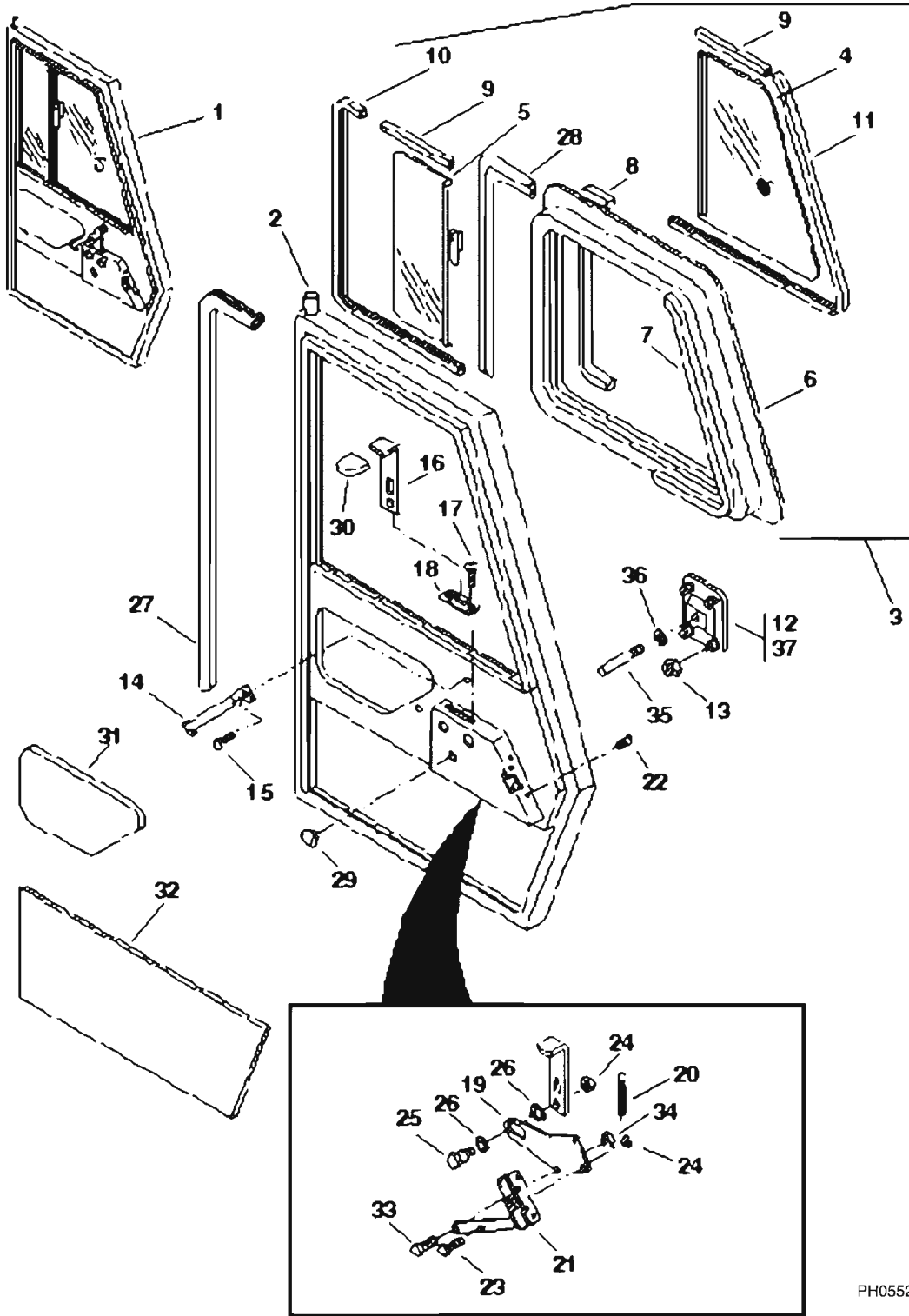

PH0552

SECTION 2 - OPERATOR'S CAB AND CONTROLS

FIGURE 2-3. CAB DOOR

ITEM	PART NUMBER	QTY	DESCRIPTION	REV
1	8346008	1	Door Assembly (Includes Items 2 thru 36)	
2	8033844	1	Door Weldment	
3	8033845	1	Sliding Window Assembly (Includes Items 4 thru 11)	
4	8033843	1	Glass Assembly - Front	
5	8033842	1	Glass Assembly - Rear	
6	8033841	1	Frame Assembly	
7	8034544	1	Trim, Stop - Front	
8	8034545	1	Trim, Stop - Rear	
9	8034546	2	Rubber, Flkd	
10	8034547	1	Rubber, Flkd	
11	8034548	1	Rubber, Flkd	
12	8033846	1	Paddle Latch	
13	8033847	4	Nut, Hex Locking 1/4-20	
14	8033848	1	Grab Handle	
15	8033849	2	Screw, Self Tapping 1/4 x 3/4in	
16	8033850	1	Door Release	
17	8033851	2	Screw, Self Tapping #10-24 x 1/2in	
18	8033852	1	Bezel	
19	8033853	1	Latch Trip	
20	8033854	1	Spring	
21	8033855	1	Cam Latch - Right Side	
22	8033856	4	Bolt, 1/4-20 x 3/4in	
23	8033857	1	Bolt, Hex Hd 5/16 x 3/4in	
24	8033858	2	Nut, Hex Locking 5/16in	
25	8033859	1	Shoulder Bolt	
26	8033860	2	Washer, Nylon	
27	8033861	1	Seal, Rubber (17ft)	
28	8037206	1	Seal, Bulb "D" .216 x .354 (9.5ft)	
29	8033862	3	Hole Plug	
30	8033863	1	Rubber Grip	
31	8033864	1	Soundproofing - Upper Door	
32	8033865	1	Soundproofing - Lower Door	
33	8033866	1	Bolt, Hex Hd 3/8 x 3/4in	
34	8033867	1	Nut, Hex Locking 3/8in	
35	8033868	1	Striker Bolt	
36	80364021	1	Washer, Lock 3/8	
37	8342808	1	Key Set (Not Shown)	

SECTION 2 - OPERATOR'S CAB AND CONTROLS

FIGURE 2-4. OPERATOR'S SEAT

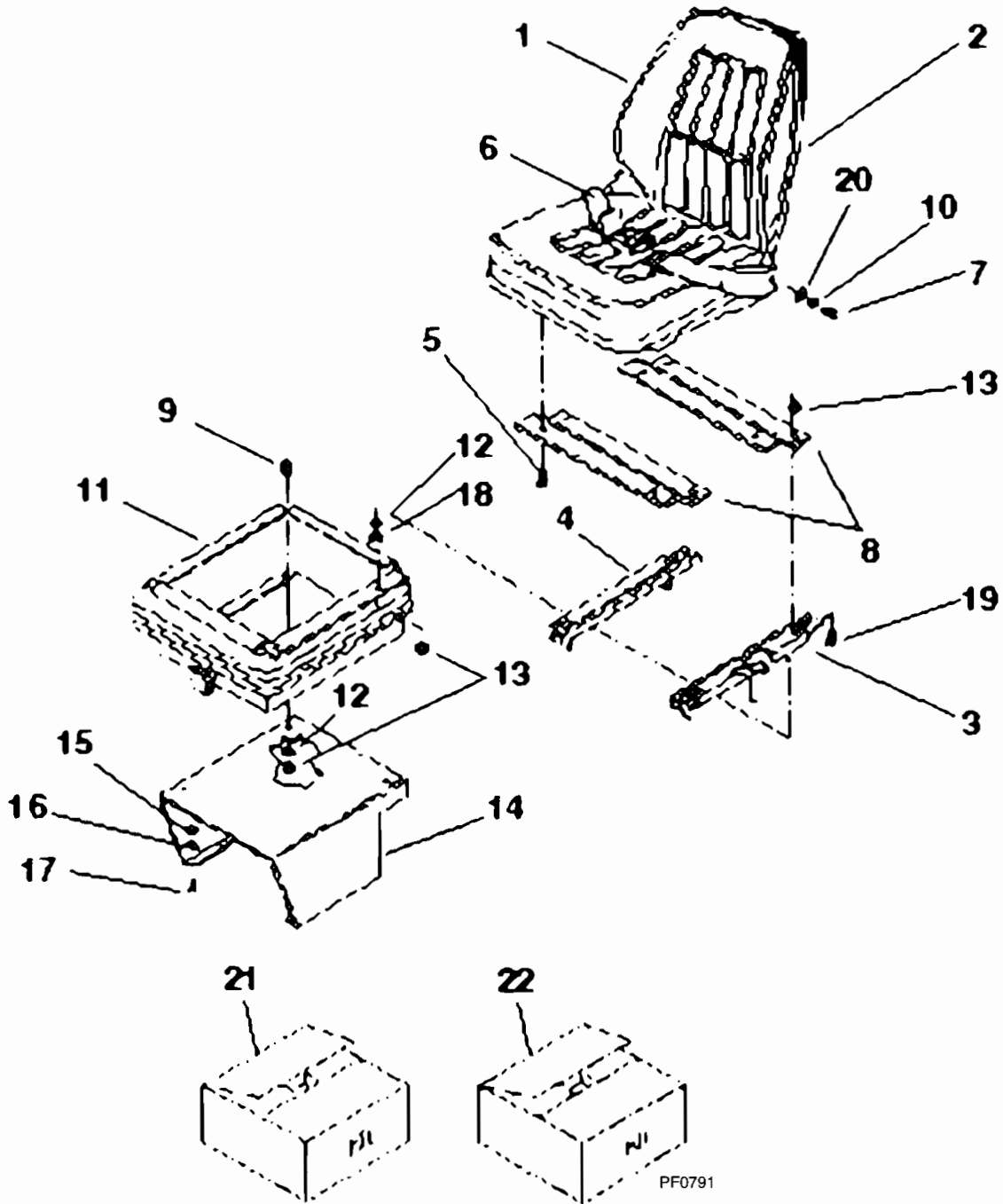

PF0791

PA0064

SECTION 2 - OPERATOR'S CAB AND CONTROLS

FIGURE 2-4. OPERATOR'S SEAT

ITEM	PART NUMBER	QTY	DESCRIPTION	REV
1	8864037	1	Seat Assembly - Vinyl (Includes Items 2 thru 5)	
1	8864044	1	Seat Assembly - Cloth 2 Piece (Includes Items 2 thru 5)	
2	8864041	1	Cushion, Seat - Vinyl (one piece)	
2	8864045	1	Cushion, Seat - Cloth	
2	8864046	1	Seat Back - Cloth	
3	8864039	1	Slide, w/Handle	
4	8864040	1	Slide, w/o Handle	
5	N.S.S.	4	Screw	
6	8864043	1	Belt, Seat	
7	8303604	2	HHCS, 7/16-20 x 1-1/4in	
8	7090751	2	Mount, Seat	
9	8303697	4	HHCS, 5/16-18 x 3/4in	
10	8307006	2	Washer, Lock 7/16in	
11	8864036	1	Suspension	
12	8307106	8	Washer, Flat 5/16in	
13	8305626	12	Nut, Hex Lock Elastic 5/16-18	
14	7083963	1	Support, Suspension	
15	8305008	4	Nut, Hex 3/8-16	
16	8307005	4	Washer, Lock 3/8in	
17	8303534	4	FLHDCS 3/8-16 x 1-1/4in	
18	8305006	4	Nut, Hex 5/16-18	
19	8303745	4	HHCS, 5/16-18 x 5/8in	
20	8307113	2	Washer, Flat 7/16in	
		Ref	KITS	
21	7143900	1	Kit, Seat Belt non-retractable 3in	
22	7144000	1	Kit, Seat Belt retractable 3in	

SECTION 2 - OPERATOR'S CAB AND CONTROLS

FIGURE 2-5. CONTROL CONSOLE

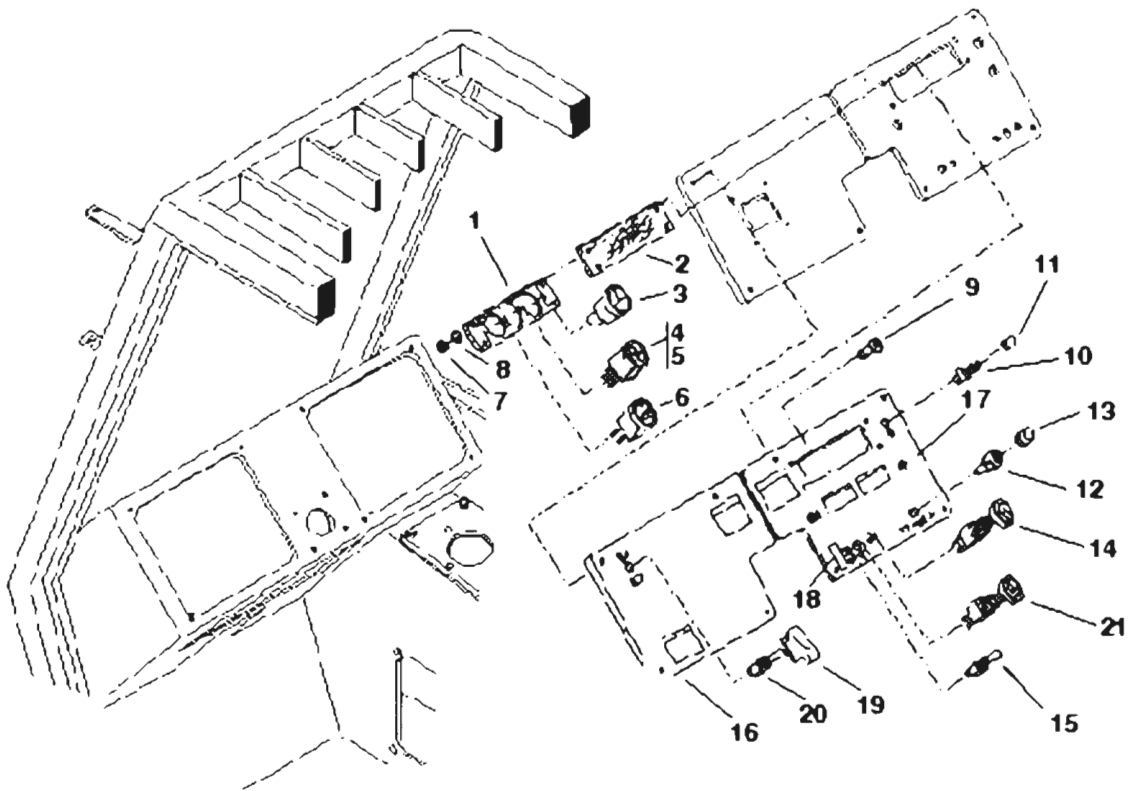

PH0543

SECTION 2 - OPERATOR'S CAB AND CONTROLS

FIGURE 2-5. CONTROL CONSOLE

ITEM	PART NUMBER	QTY	DESCRIPTION	REV
1	7084902	1	Plate, Gauge Mounting	
2	7082292	1	Cover	
3	8464212	1	Gauge, Fuel	
4	8466305	1	Gauge, Warning Lights (Includes Item 5)	
5	8469030	4	Bulb (Not Shown)	
6	8467014	1	Hourmeter	
7	8305004	4	Nut, Hex, 1/4-20	
8	8307002	4	Washer, Lock 1/4in	
9	8303034	4	TRHCS, Torx 1/4-20 x 3/4in	
10	8223442	1	Switch Test	
11	8580312	1	Cap, Seal	
12	8223405	1	Button, Horn	
13	8580311	1	Cap, Seal	
14	8033201	1	Switch, Washer/Wiper Front (Optional)	
15	8223220	1	Switch, Steer Select	
16	7099352	1	Overlay, Left Console - Domestic (Prior to SN 9909)	
16	7150371	1	Overlay, Left Console - Domestic (SN 9909 to Present)	
16	7111842	1	Overlay, Left Console - Export (Prior to SN 9909)	
16	7150472	1	Overlay, Left Console - Export (SN 9909 to Present)	
17	7099332	1	Overlay, Right Console - Domestic	
17	7111832	1	Overlay, Right Console - Export	
18	4107971	1	Decal, Outrigger Contact - Domestic (10054 Only)	
18	4107981	1	Decal, Outrigger Contact - Export (10054 Only)	
19	8223445	1	Guard, Switch	
20	8223444	1	Emergency Brake Switch	
21	7135942	1	Switch, Skylight Wiper (Optional)	

SECTION 2 - OPERATOR'S CAB AND CONTROLS

FIGURE 2-6. TRANSMISSION SHIFT CONTROLS (Prior to SN 9909)

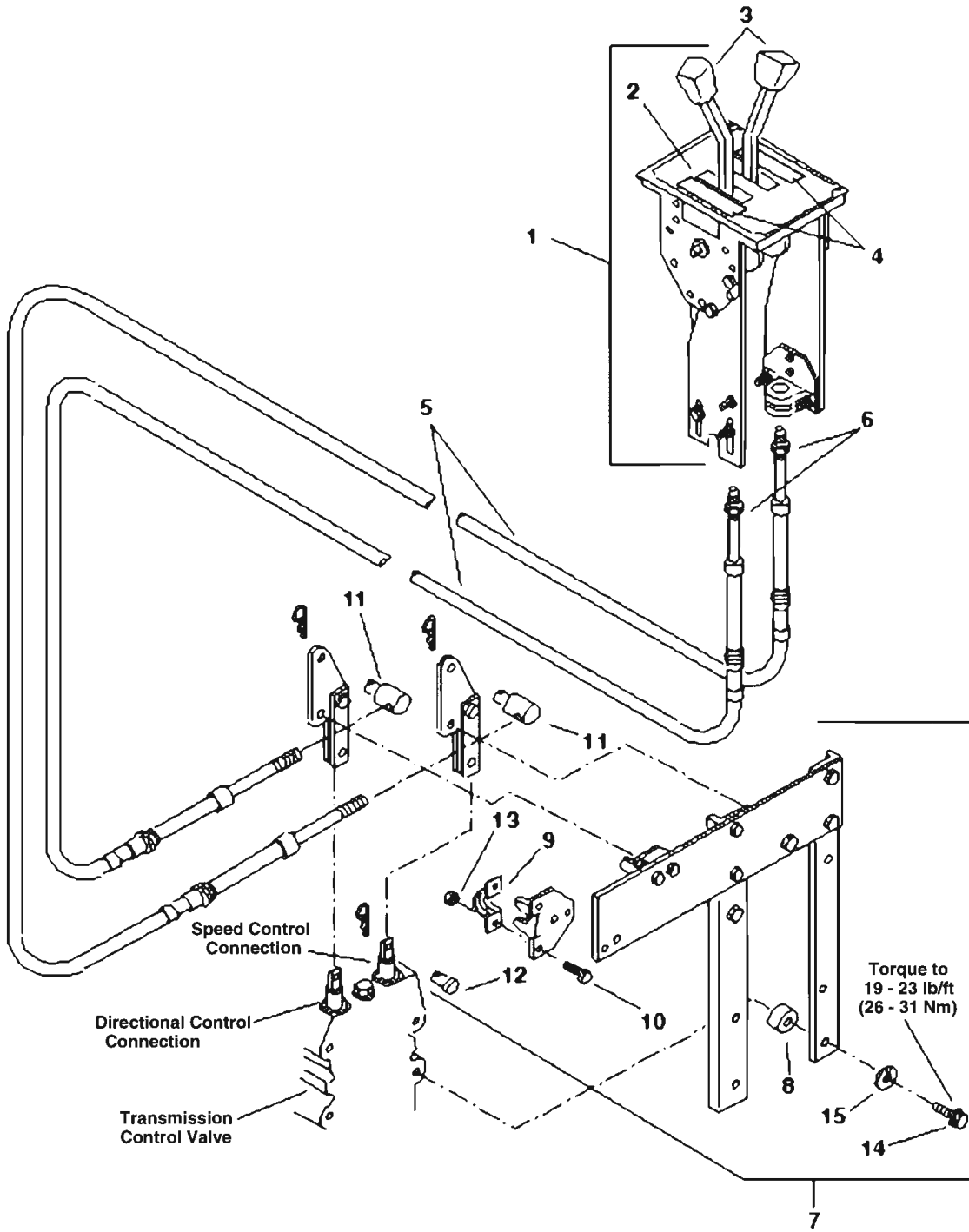

SECTION 2 - OPERATOR'S CAB AND CONTROLS

FIGURE 2-6. TRANSMISSION SHIFT CONTROLS (Prior to SN 9909)

ITEM	PART NUMBER	QTY	DESCRIPTION	REV
1	8160205	1	Shifter, Transmission (Includes Items 2 thru 4)	
2	8034694	1	Gate Plate	
3	8580111	2	Knob	
4	8032753	1	Decal Kit (Contains F-N-R & 3-2-1 Decals)	
5	8160042	2	Cable, Control	
6	8305402	2	Nut, Hex Jam 1/4-28	
7	8160417	1	Transmission Connector Kit (Includes Items 8 thru 15 plus all other parts not identified with an Item number)	
8	8033240	4	Spacer	
9	8033241	2	Clamp	
10	8303540	4	HHCS, 1/4-20 x 1in	
11	8033242	2	Swivel	
12	8033243	2	Pin, Clevis	
13	8305601	4	Nut, Lock	
14	8303106	4	HHCS, 3/8-16 x 2-1/2in	
15	8307005	4	Washer, Lock 3/8in	

SECTION 2 - OPERATOR'S CAB AND CONTROLS

FIGURE 2-7. TRANSMISSION SHIFT CONTROLS (SN 9909 through 13197)

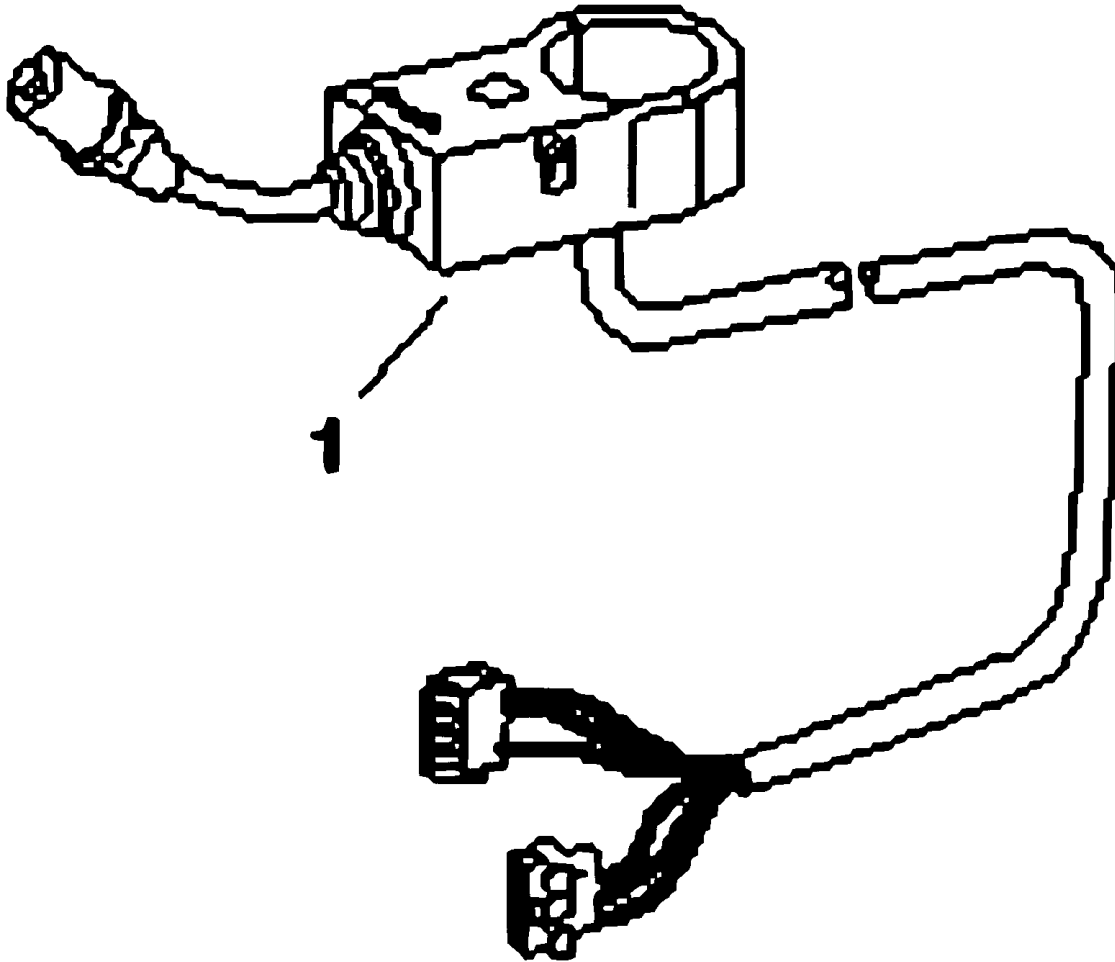

PH1201

SECTION 2 - OPERATOR'S CAB AND CONTROLS

FIGURE 2-7. TRANSMISSION SHIFT CONTROLS (SN 9909 through 13197)

ITEM	PART NUMBER	QTY	DESCRIPTION	REV
1	1319283	1	Shifter, Transmission Range Selector	

SECTION 2 - OPERATOR'S CAB AND CONTROLS

FIGURE 2-8. BOOM RAISE/LOWER AND EXTEND/RETRACT CONTROL

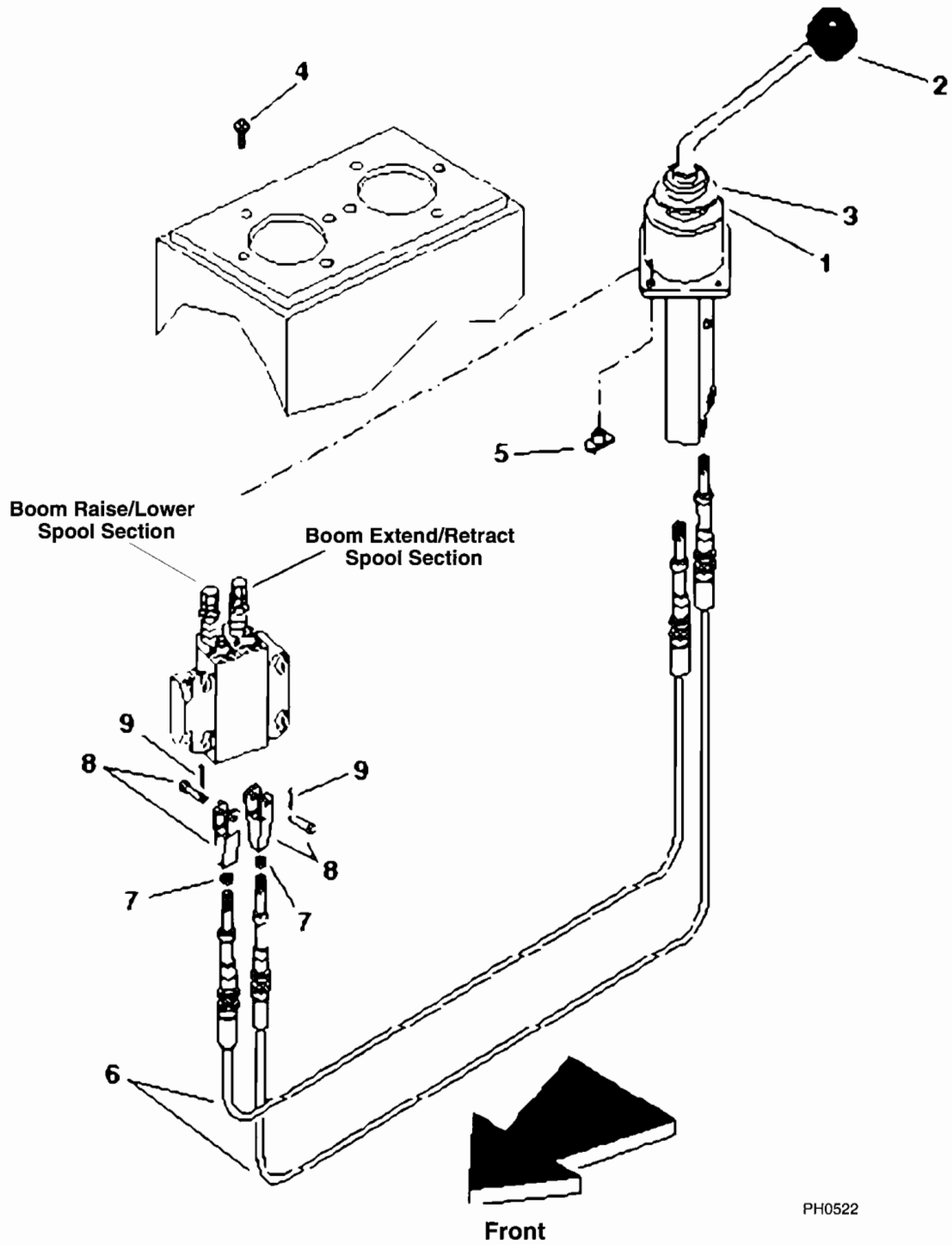

PH0522

SECTION 2 - OPERATOR'S CAB AND CONTROLS

FIGURE 2-8. BOOM RAISE/LOWER AND EXTEND/RETRACT CONTROL

ITEM	PART NUMBER	QTY	DESCRIPTION	REV
1	8224027	1	Joystick (Includes Items 2 & 3)	
2	8580110	1	Knob	
3	8160419	1	Boot	
4	8310143	4	TRHCS #10-24	
5	8310144	4	Nut, Prop Tee #10-24	
6	8160062	2	Cable, Control	
7	8305402	4	Nut, Hex Jam 1/4-28	
8	8301439	2	Clevis, with Pin and Cotter	
9	8302470	2	Pin, Hair 1/16in	

SECTION 2 - OPERATOR'S CAB AND CONTROLS

FIGURE 2-9. FRAME LEVEL AND ATTACHMENT TILT CONTROL

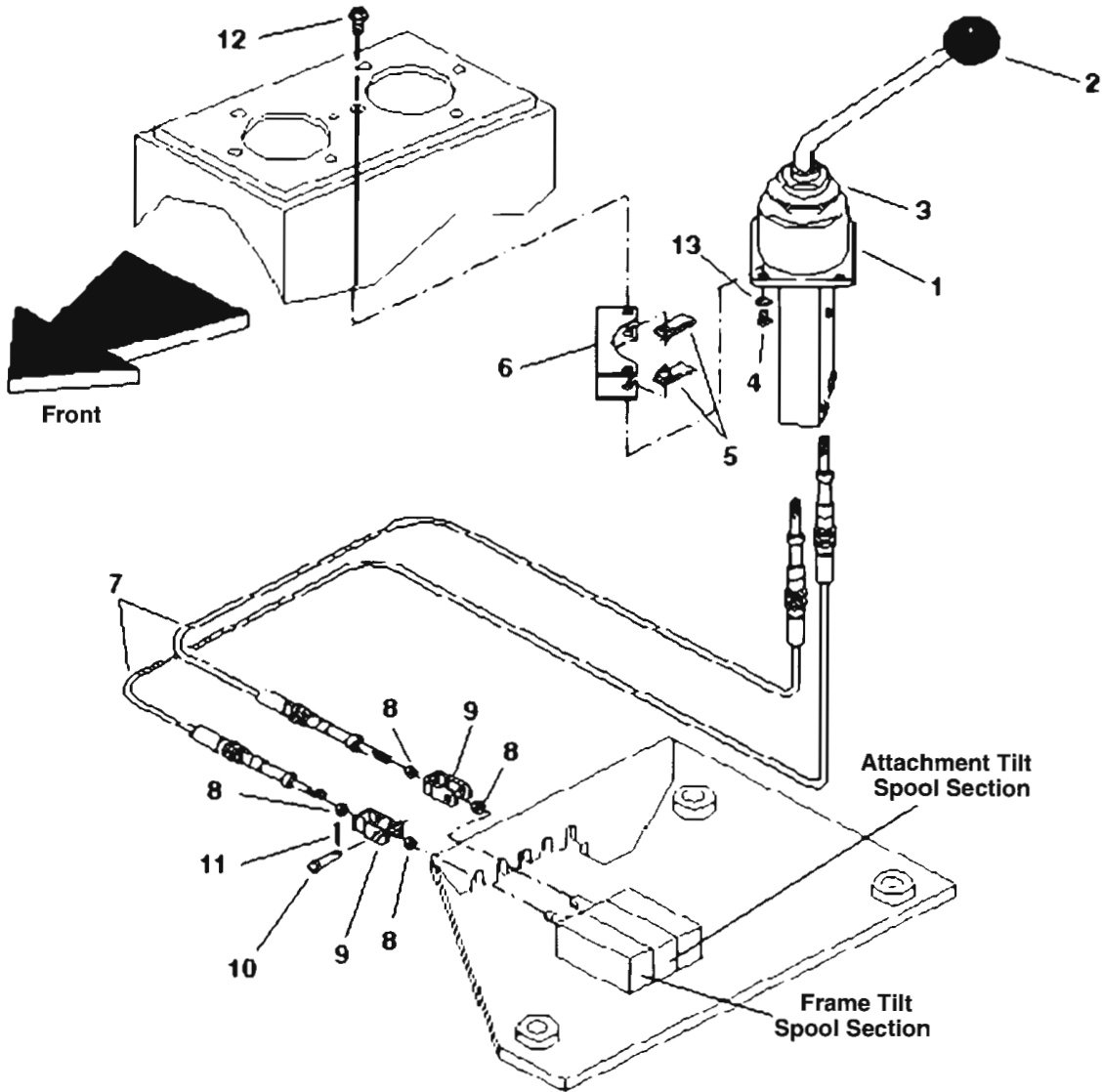

PH0512

SECTION 2 - OPERATOR'S CAB AND CONTROLS

FIGURE 2-9. FRAME LEVEL AND ATTACHMENT TILT CONTROL

ITEM	PART NUMBER	QTY	DESCRIPTION	REV
1	8224026	1	Joystick, With Gate (Includes Items 2 & 3)	
2	8580110	1	Knob	
3	8160419	1	Boot	
4	8303540	4	HHCS, 1/4-20 x 1in	
5	8310001	8	Nut, Retainer 1/4-20	
6	7098142	2	Spacer	
7	8160060	2	Cable, Control	
8	8305005	4	Nut, Hex 1/4-28	
9	8160617	2	Clevis, Cable	
10	8301443	2	Pin, Clevis 3/16 x 1in	
11	8302470	2	Pin, Hair 1/16in	
12	8303034	4	TRHCS, Torx 1/4-20 x 3/4in	
13	8307109	4	Washer, Flat 1/4in	

SECTION 2 - OPERATOR'S CAB AND CONTROLS

FIGURE 2-10. THROTTLE PEDAL CONTROL

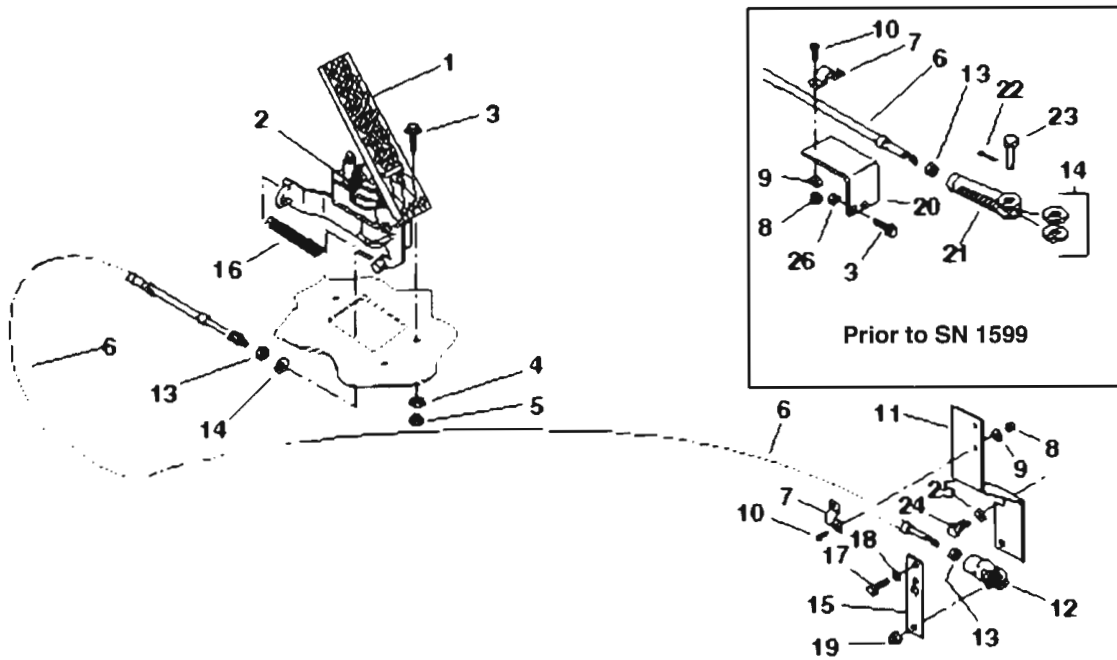

PH0592

SECTION 2 - OPERATOR'S CAB AND CONTROLS

FIGURE 2-10. THROTTLE PEDAL CONTROL

ITEM	PART NUMBER	QTY	DESCRIPTION	REV
1	8162003	1	Pedal, Throttle (Includes Item 2)	
2	8033178	1	Bellows, Throttle Pedal	
3	8303742	3	FLHDCS 1/4-20 x 1in (Qty 3 for EPA Engines, Qty 5 for Pre-EPA Engines)	
4	8307002	3	Washer, Lock 1/4in	
5	8305004	3	Nut, Hex 1/4-20	
6	8160046	1	Cable, Throttle	
7	8160610	1	Clamp, Cable	
8	8305002	2	Nut, Hex #10-24	
9	8307003	2	Washer, Lock #10	
10	8303837	2	Screw, Round Hd #10-24 x 3/4in	
11	7127102	1	Bracket, Throttle Cable (EPA Engines)	
12	8340034	1	Rod End	
13	8305402	2	Nut, Jam .25 NF	
14	8307109	AR	Washer, Flat SAE 1/4in	
15	7127091	1	Extension, Throttle Lever	
16	8700116	1	Spring	
17	8303799	2	HHCS, M6 x 14mm	
18	8307024	2	Washer, Lock M6	
19	8305650	1	Nut, Lock .25 NF	
20	7088522	1	Bracket, Throttle Cable (Pre-EPA Engines)	
21	8301002	1	Clevis	
22	8302449	1	Pin, Cotter	
23	8301402	1	Pin, Yoke	
24	8303790	2	HHCS, M12 x 30mm	
25	8307025	2	Washer, Lock M12	
26	8305624	2	Nut, Hex Lock Elastic	

SECTION 2 - OPERATOR'S CAB AND CONTROLS

FIGURE 2-11. SERVICE BRAKE PEDAL CONTROL

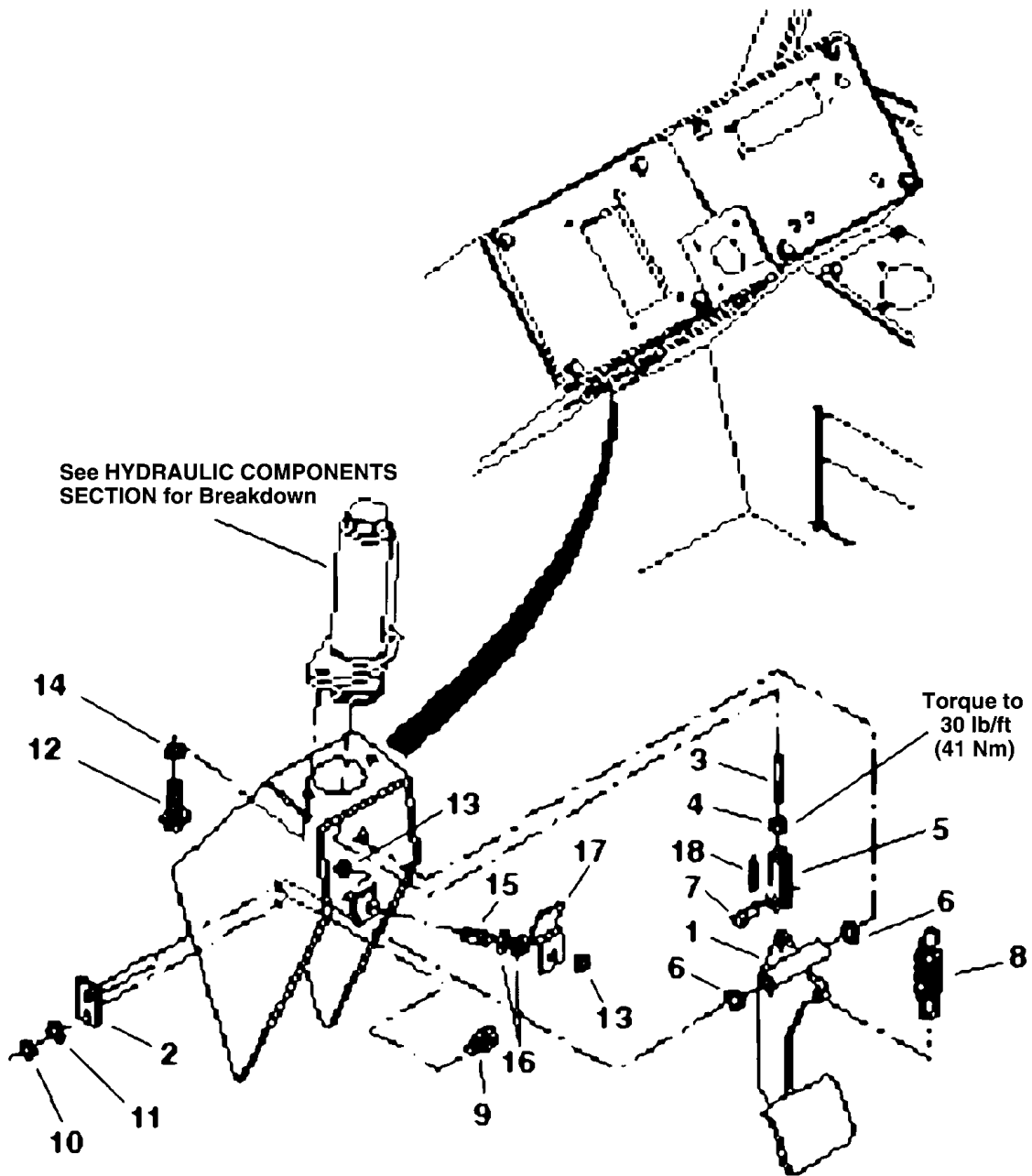

PG0531

SECTION 2 - OPERATOR'S CAB AND CONTROLS

FIGURE 2-11. SERVICE BRAKE PEDAL CONTROL

ITEM	PART NUMBER	QTY	DESCRIPTION	REV
1	7111203	1	Pedal, Brake	
2	7081031	1	Shaft	
3	7080891	1	Rod, Push	
4	8305410	1	Nut, Jam 1/2-20	
5	8310257	1	Yoke	
6	8307104	2	Washer, Flat 3/4in	
7	8310258	1	Pin, Clevis	
8	8700120	1	Spring	
9	8303742	1	FLHDCS, 1/4-20 x 1-1/4in	
10	8305004	1	Nut, Hex 1/4-20	
11	8307002	1	Washer, Lock 1/4in	
12	8303534	2	FLHDCS, 3/8-16 x 1-1/4in	
13	8305405	2	Nut, Jam 3/8-16	
14	8307005	2	Washer, Lock 3/8in	
15	8310170	1	Screw, Set 3/8-16 x 1-3/4in	
16	8307110	2	Washer, Flat 3/8in	
17	7111191	1	Plate, Actuator	
18	8302406	1	Cotter Pin, 1/8in x 1in	

SECTION 2 - OPERATOR'S CAB AND CONTROLS

FIGURE 2-12. FRONT WINDSHIELD WIPER

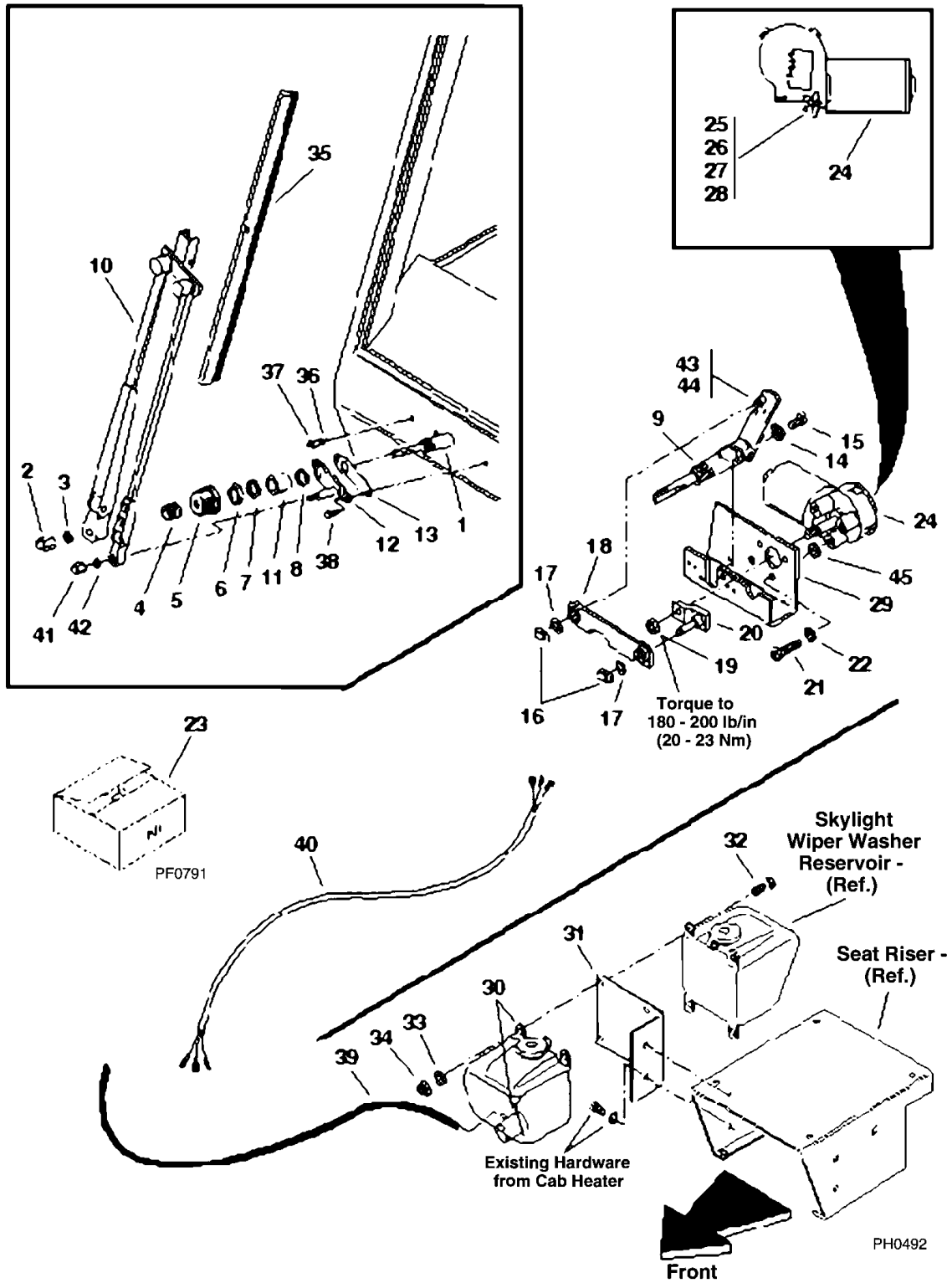

SECTION 2 - OPERATOR'S CAB AND CONTROLS

FIGURE 2-12. FRONT WINDSHIELD WIPER

ITEM	PART NUMBER	QTY	DESCRIPTION	REV
1	8866492	1	Pivot Arm and Shaft Assembly (Includes Items 2 thru 9)	
2	N.S.S.	1	Nut, Acorn 3/8-24	
3	N.S.S.	1	Washer, Internal Tooth Lock 3/8in	
4	N.S.S.	1	Driver, Knurled	
5	N.S.S.	1	Cap, Rubber	
6	N.S.S.	1	Nut, Hex Jam 11/16-24	
7	N.S.S.	1	Washer, Metal	
8	N.S.S.	1	Washer, Cardboard	
9	N.S.S.	1	Shaft Assembly	
10	8866382	1	Wiper Arm - 22in	
11	91334035	1	Spacer	
12	8034815	1	Panto Adapter Kit (Includes Items 13, 38, 41 & 42)	
13	N.S.S.	1	Gasket, Panto (Order P/N 8034815)	
14	8307052	2	Washer, External Tooth Lock #10	
15	8303839	2	Screw, Slotted Pan Head #10-32 x 1/2in	
16	N.S.S.	2	Clip, Spring (Order Item 24)	
17	N.S.S.	2	Washer, Special Flat .5600 x .2510 x .015 (Order Item 24)	
18	8033104	1	Link, Connecting	
19	8305006	1	Nut, Hex Flanged 5/16-18	
20	8866437	1	Drive Arm	
21	N.S.S.	3	Screw, Slotted Hex Head Cap 1/4-28 x 3/4in (Order Item 24)	
22	8310002	3	Washer, External Tooth Lock 1/4in	
23	7112511	1	Wiper Motor Kit (Includes Items 20, 24 thru 29)	
24	8033102	1	Wiper Motor Assembly (Includes mounting bracket, motor, link and hardware)	
24	7029860	1	Wiper Motor Assembly (includes mounting bracket, motor, link and hardware)	
25	8220073	1	Adapter, 1/4in Male Blade	
26	8303835	1	Screw, Pan Head #10-24 x 1/2in	
27	8305002	1	Nut, Hex #10-24	
28	8307046	1	Washer, Internal Tooth Lock #10	
29	N.S.S.	1	Bracket, Wiper Motor (Order Item 24)	
30	8033065	1	Washer Reservoir Assembly w/washer pump	
31	7118941	1	Bracket, Washer Bottle Mounting	
32	8303540	3	HHCS, 1/4-20 x 1in	
33	8307109	3	Washer, Flat 1/4in	
34	8305624	3	Nut, Lock 1/4-20	
35	8866381	1	Wiper Blade - 22in	
36	8034801	1	Spray Nozzle	
37	8554008	1	Nozzle Tip	
38	80384207	2	SCREW, 1/4-28X3/4, (enclosed cab)	
39	8033075	1	Hose, Washer 120in	
40	8033103	1	Cable, Wiper	
41	N.S.S.	1	Nut, Acorn 1/4-28 (Order Item 12)	
42	8310029	1	Washer, Internal Tooth Lock 1/4in	
43	N.S.S.	1	Pin, Shoulder (Order Item 1)	
44	8305005	1	Nut, Hex 1/4-28	
45	8307203	3	Washer, Flat 5/16in	

SECTION 2 - OPERATOR'S CAB AND CONTROLS

FIGURE 2-13. CAB HEATER (OPTIONAL)

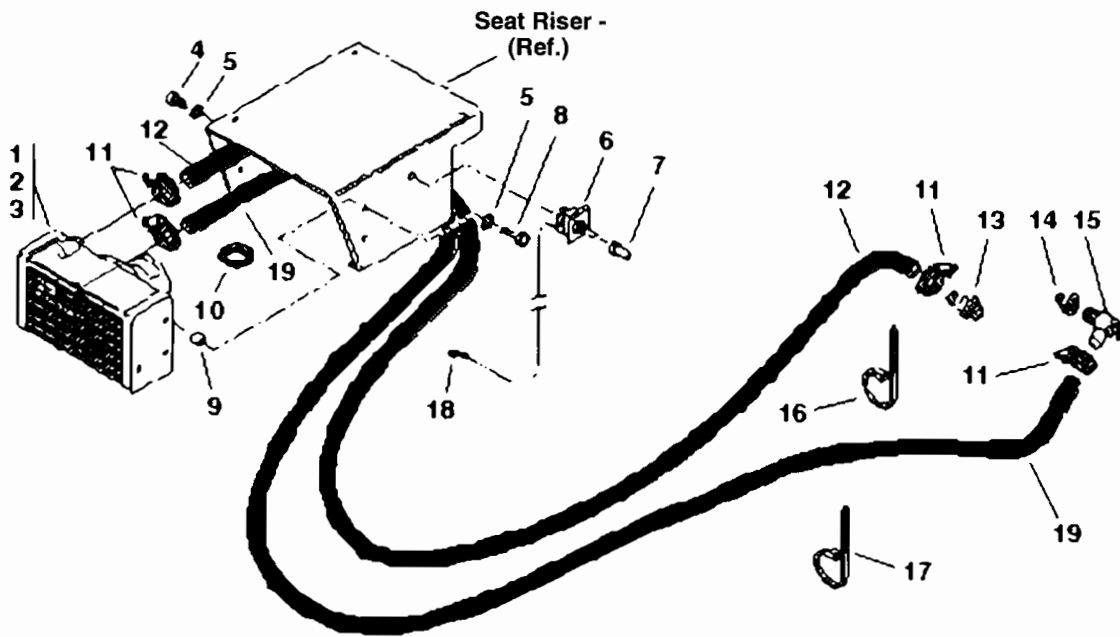

PG0561

SECTION 2 - OPERATOR'S CAB AND CONTROLS

FIGURE 2-13. CAB HEATER (OPTIONAL)

ITEM	PART NUMBER	QTY	DESCRIPTION	REV
1	8360008	1	Heater (Includes Items 2 & 3)	
2	8032793	1	Motor, Heater - 12 VDC	
3	8032794	1	Fan, Heater	
4	8303776	2	HHCS, 1/4-20 x 1/2in	
5	8307002	4	Washer, Lock 1/4in	
6	8223024	1	Switch Kit	
7	8580309	1	Cap	
8	8303995	2	HHCS, #10-24 x 1-1/4in	
9	7075191	2	Spacer, 3/4in	
10	7124531	2	Conduit, 1/4 I.D. x 5in	
11	8405007	4	Clamp	
12	7125251	2	Hose, 5/8 I.D. x 120in	
13	8430048	1	Hose Fitting, Beaded, SAE 10-8P - hose I.D. x male NPT	
14	8540023	1	Reducer, 3/8in NPT x 1/2in NPT	
15	8360005	1	Valve, Shut-off	
16	8584001	1	Tie Wrap, .2 wide x 6.7in	
17	8584003	6	Tie Wrap, .3 wide x 14.8in	
18	8220008	1	Terminal, #10	
19	7125271	1	Hose, 5/8 I.D. x 156in	

SECTION 2 - OPERATOR'S CAB AND CONTROLS

FIGURE 2-14. AUX. HYDRAULIC CONTROL (OPTIONAL)

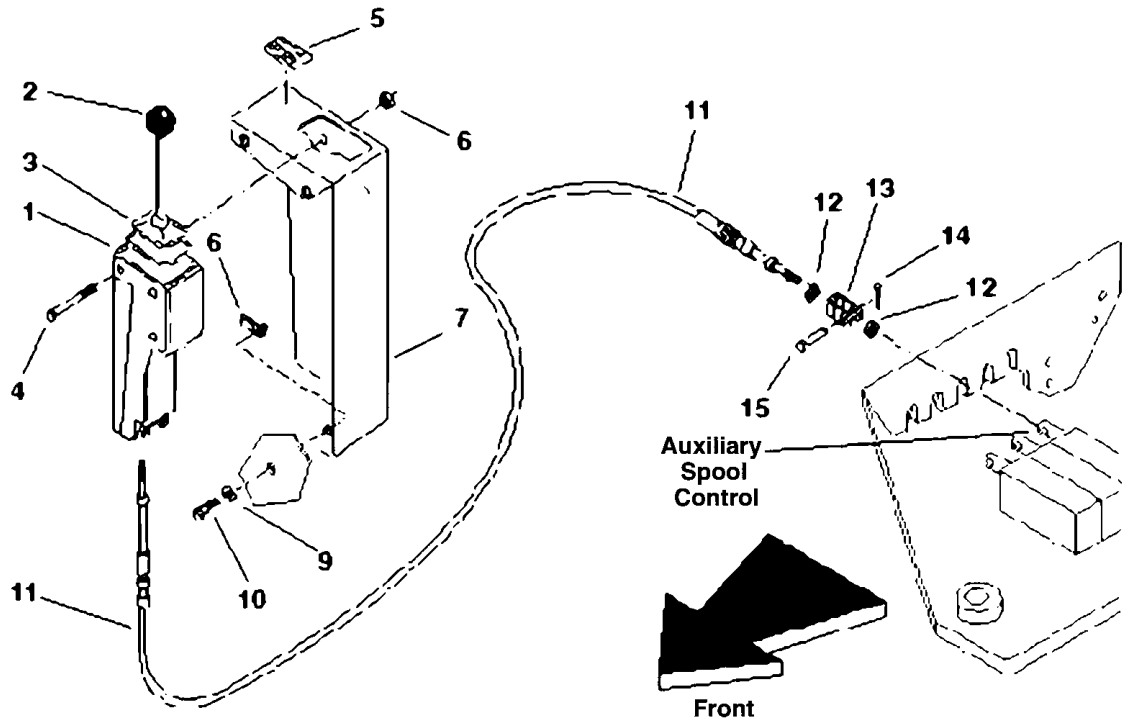

PH0501

SECTION 2 - OPERATOR'S CAB AND CONTROLS

FIGURE 2-14. AUX. HYDRAULIC CONTROL (OPTIONAL)

ITEM	PART NUMBER	QTY	DESCRIPTION	REV
1	8160406	1	Controller (Includes Items 2 & 3)	
2	8580110	1	Knob	
3	8160418	1	Boot	
4	8303758	2	HHCS, 1/4-20 x 2in	
5	4105621	1	Decal, Auxiliary Control	
6	8305004	2	Nut, Hex 1/4-20	
7	7091323	1	Support, Controller	
8	8305906	3	Nut, Retaining 5/16-18	
9	8307004	3	Washer, Lock 5/16in	
10	8303697	3	HHCS, 5/16-18 x 3/4in	
11	8160059	1	Cable, Control	
12	8305402	2	Nut, Jam 1/4-28	
13	8160617	1	Clevis	
14	8302470	1	Pin, Cotter	
15	8301443	1	Pin, Clevis	

SECTION 2 - OPERATOR'S CAB AND CONTROLS

FIGURE 2-15. MIRRORS

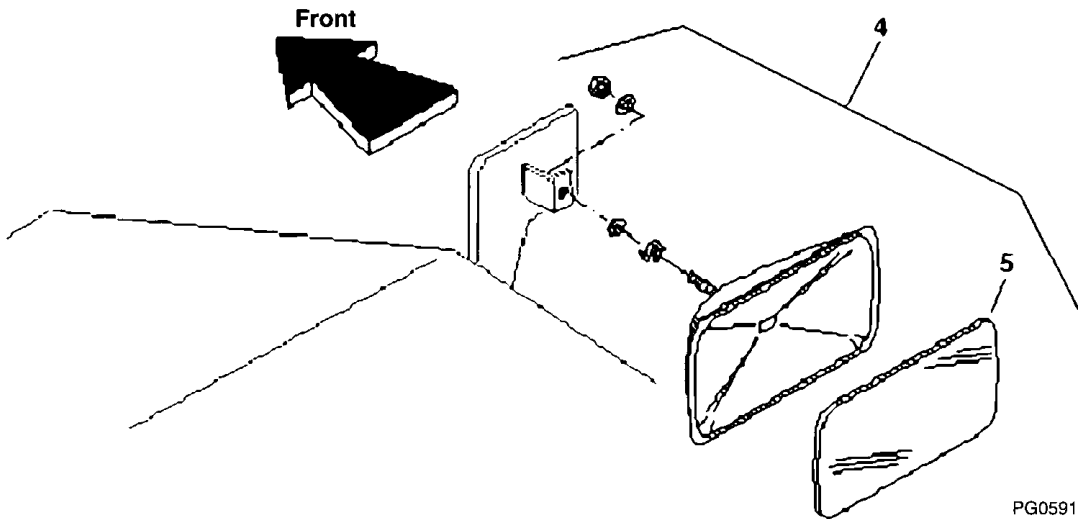
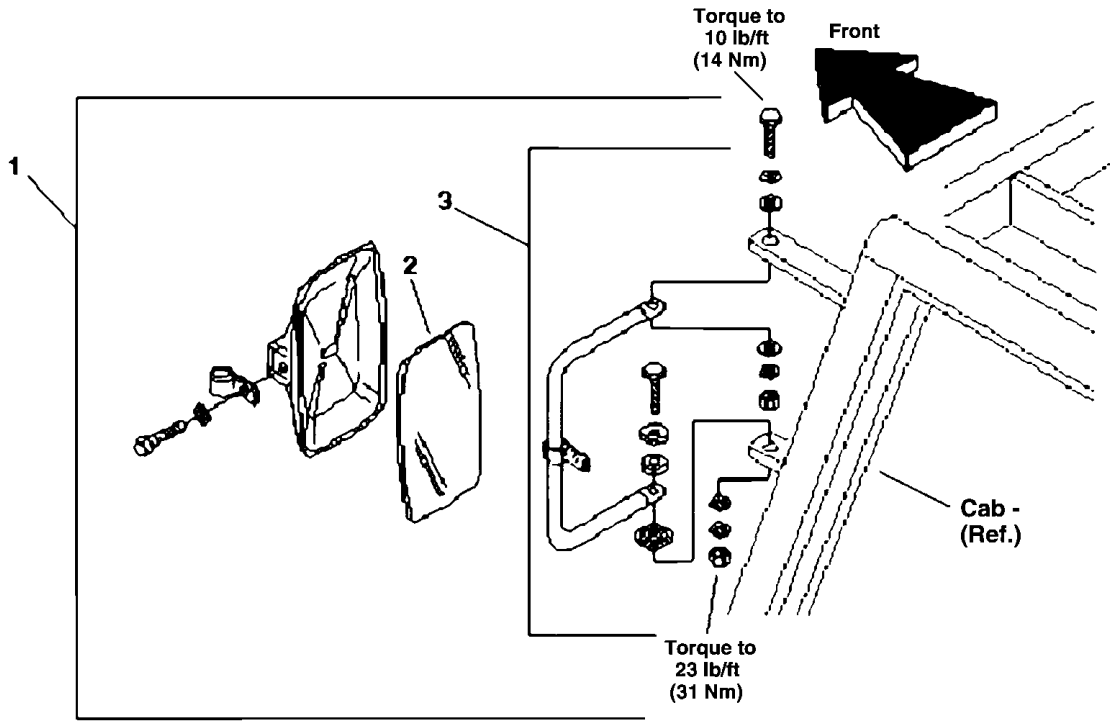

PG0591

SECTION 2 - OPERATOR'S CAB AND CONTROLS

FIGURE 2-15. MIRRORS

ITEM	PART NUMBER	QTY	DESCRIPTION	REV
1	8866347	1	Mirror Assembly, 6.5in x 10in, Left Side Cab - Flat Glass (Includes Items 2 & 3)	
2	8866350	1	Lens, 6.5in x 10in Flat Glass Replacement	
3	8866364	1	Loop Assembly	
4	8866348	1	Mirror Assembly, 6.5in x 10in Right Side - Convex Glass (Includes Item 5 and mounting hardware)	
5	8866351	1	Lens, 6.5in x 10in Convex Glass Replacement	

SECTION 2 - OPERATOR'S CAB AND CONTROLS

FIGURE 2-16. SKYLIGHT WINDSHIELD WIPER (OPTIONAL)

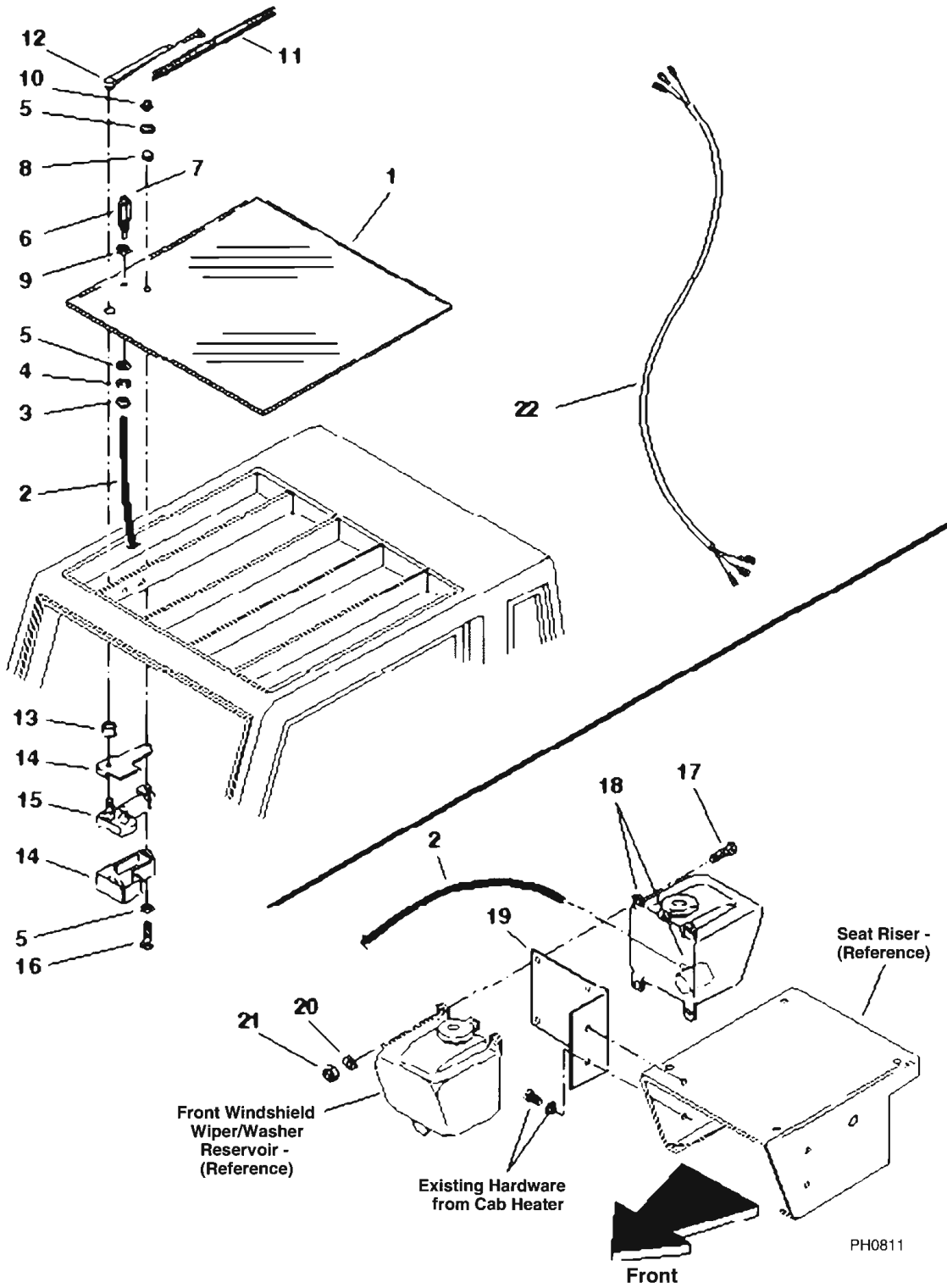

SECTION 2 - OPERATOR'S CAB AND CONTROLS

FIGURE 2-16. SKYLIGHT WINDSHIELD WIPER (OPTIONAL)

ITEM	PART NUMBER	QTY	DESCRIPTION	REV
1	8034797	1	Window, Skylight	
2	8033075	1	Hose, Washer 120in (cut to length)	
3	8034798	2	Nut, Hex 5/16-18	
4	8034799	2	Washer, Lock 5/16in	
5	8034800	3	Washer, Black Nylon 5/16in	
6	8034801	1	Spray Nozzle	
7	8554008	1	Nozzle Tip	
8	8034803	1	Grommet, T-Style	
9	8034804	1	Washer, Weather Tight	
10	8034805	1	Nut, Acorn #10-24	
11	8034806	1	Wiper Blade - 20in	
12	8034807	1	Wiper Arm, 15-19in Adjustable	
13	8034808	1	Spacer, Nylon	
14	8034809	1	Wiper Cover Assembly	
15	7137132	1	Kit, Wiper Motor and Switch w/Breaker (SN P6931A through P8239B)	
15	8034810	1	Skylight Wiper Motor Kit, WWF Auto-SP (SN P8239C to Present)	
16	8034811	1	Screw, #10-24 x 7/8in	
17	8303540	3	HHCS, 1/4-20 x 1in	
18	8033065	1	Washer Reservoir Assembly (Includes washer pump)	
19	7118941	1	Bracket, Washer Bottle Mounting	
20	8307109	3	Washer, Flat 1/4in	
21	8305624	3	Nut, Lock 1/4-20	
22	8034817	1	Wire Harness, Skylight Wiper	

SECTION 2 - OPERATOR'S CAB AND CONTROLS

FIGURE 2-17. SOFT CAB ENCLOSURE (OPTIONAL)

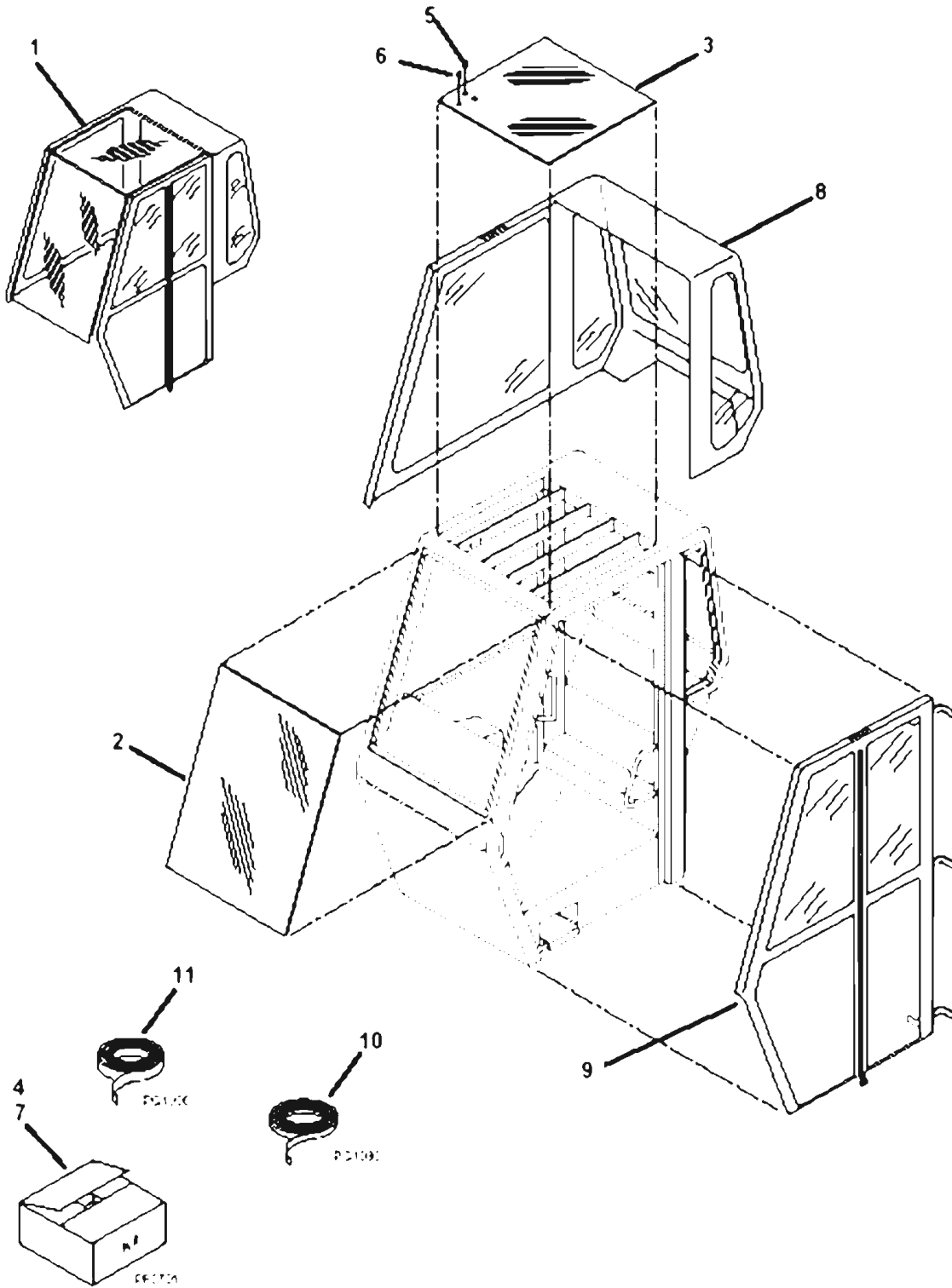

SECTION 2 - OPERATOR'S CAB AND CONTROLS

FIGURE 2-17. SOFT CAB ENCLOSURE (OPTIONAL)

ITEM	PART NUMBER	QTY	DESCRIPTION	REV
7	8866525	1	Soft Cab Enclosure Kit - Complete (Includes Items 2 thru 7 plus Installation Instructions)	
8	8866526	1	Rear Window Enclosure - Soft	
9	8866527	1	Door Section - Soft	
5	8033081	1	Glass - Top	
2	8033479	1	Glass - Front	
10	8585155	1	1in Hook Strip Material - 10 ft	
11	8585156	1	2in Hook Strip Material - 10 ft	
4	8585133	1	Window Glue Kit	

SECTION 3 - DRIVE TRAIN

SECTION 3 - DRIVE TRAIN

FIGURE 3-1. CONVERTER AND TRANSMISSION HOUSINGS (Prior to SN 9909)

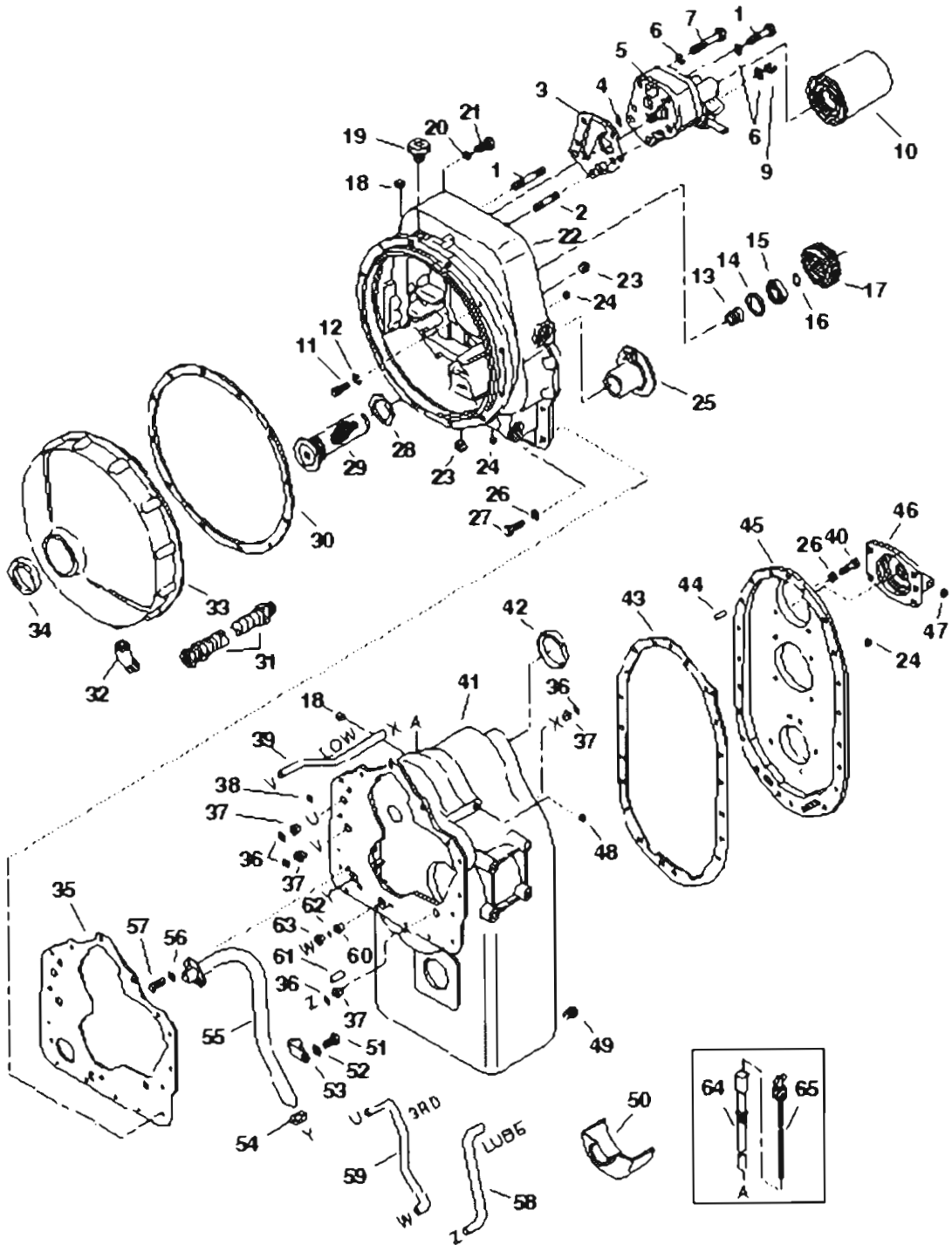

PB0183

SECTION 3 - DRIVE TRAIN

FIGURE 3-1. CONVERTER AND TRANSMISSION HOUSINGS (Prior to SN 9909)

ITEM	PART NUMBER	QTY	DESCRIPTION	REV
1	8032510	1	Pump Mounting Stud	
2	8032511	1	Pump Mounting Stud	
3	8032500	1	Gasket, Pump To Converter Housing	
4	8032501	1	O-Ring	
5	8032502	1	Charging Pump Kit (Contains replacement pump & mounting hardware)	
6	8032503	5	Washer, Lock	
7	8032504	1	Screw	
8	8032505	2	Screw	
9	8032506	2	Nut, Stud	
10	8320254	1	Filter Assembly	
11	8032541	2	Screw	
12	8307005	2	Washer, Lock	
13	8032542	1	Support, Bearing	
14	8032543	1	Retaining Ring	
15	90204788	1	Bearing, Pump Drive Gear	
16	8032545	1	Ring, Locating	
17	8032546	1	Gear, Drive	
18	8033886	2	Pipe Plug	
19	8032509	1	Air Breather	
20	8307005	11	Washer, Lock	
21	8032547	11	Screw	
22	N.S.S.	1	Housing, Converter	
23	8032515	2	Pipe Plug	
24	77104116	3	PIPE PLUG	
25	8032517	1	Sleeve, Converter Housing	
26	8033887	36	Washer, Lock	
27	8033888	16	Screw	
28	90204799	1	Gasket, Screen Assy	
29	8032518	1	Screen Assembly	
30	8032549	1	Gasket, Front Cover	
31	8033188	1	Drain Hose Assembly	
32	8033189	1	Hose Adaptor	
33	8033193	1	Cover, Converter Housing Front	
34	8033198	1	Oil Seal, Front Cover	
35	8032537	1	Gasket, Housing To Case	
36	8032523	4	O-Ring	
37	8032522	4	Tube Sleeve	
38	8032501	1	O-Ring	
39	8032538	1	Tube, Low Speed Clutch Pressure	
40	8033889	20	Screw	
41	8033314	1	Transmission Case Assembly (Includes Items 37, 39, 54 thru 59, 60, 62 & 63)	
42	8033303	1	Bore Plug	
43	8033302	1	Gasket, Rear Cover To Case	
44	8032521	2	Dowel Pin	
45	8033349	1	Rear Cover and Plug Assembly (Includes one of Item 24)	
46	8033299	1	Low Shaft Rear Bearing Cap Assembly (Includes Item 47)	
47	8032526	1	Plug	
48	8032539	1	Pipe Plug	

SECTION 3 - DRIVE TRAIN

ITEM	PART NUMBER	QTY	DESCRIPTION	REV
49	8032528	2	Magnetic Drain Plug	
50	8033311	1	Oil Baffle	
51	8033312	1	Screw	
52	8032503	1	Washer, Lock	
53	8033313	1	Clip, Suction Tube	
54	8032532	1	O-Ring	
55	8033304	1	Suction Tube Assembly	
56	8032535	2	Washer, Lock	
57	8032536	2	Screw	
58	8033305	1	Clutch Lube Tube	
59	8033306	1	3rd Speed Tube	
60	8033307	1	Tube Sleeve	
61	8032521	1	Dowel Pin	
62	8032532	1	O-Ring	
63	8033308	1	Plug	
64	8033309	1	Dipstick Tube Assembly	
65	8033310	1	Dipstick	

SECTION 3 - DRIVE TRAIN

FIGURE 3-2. CONVERTER GROUP (Prior to SN 9909)

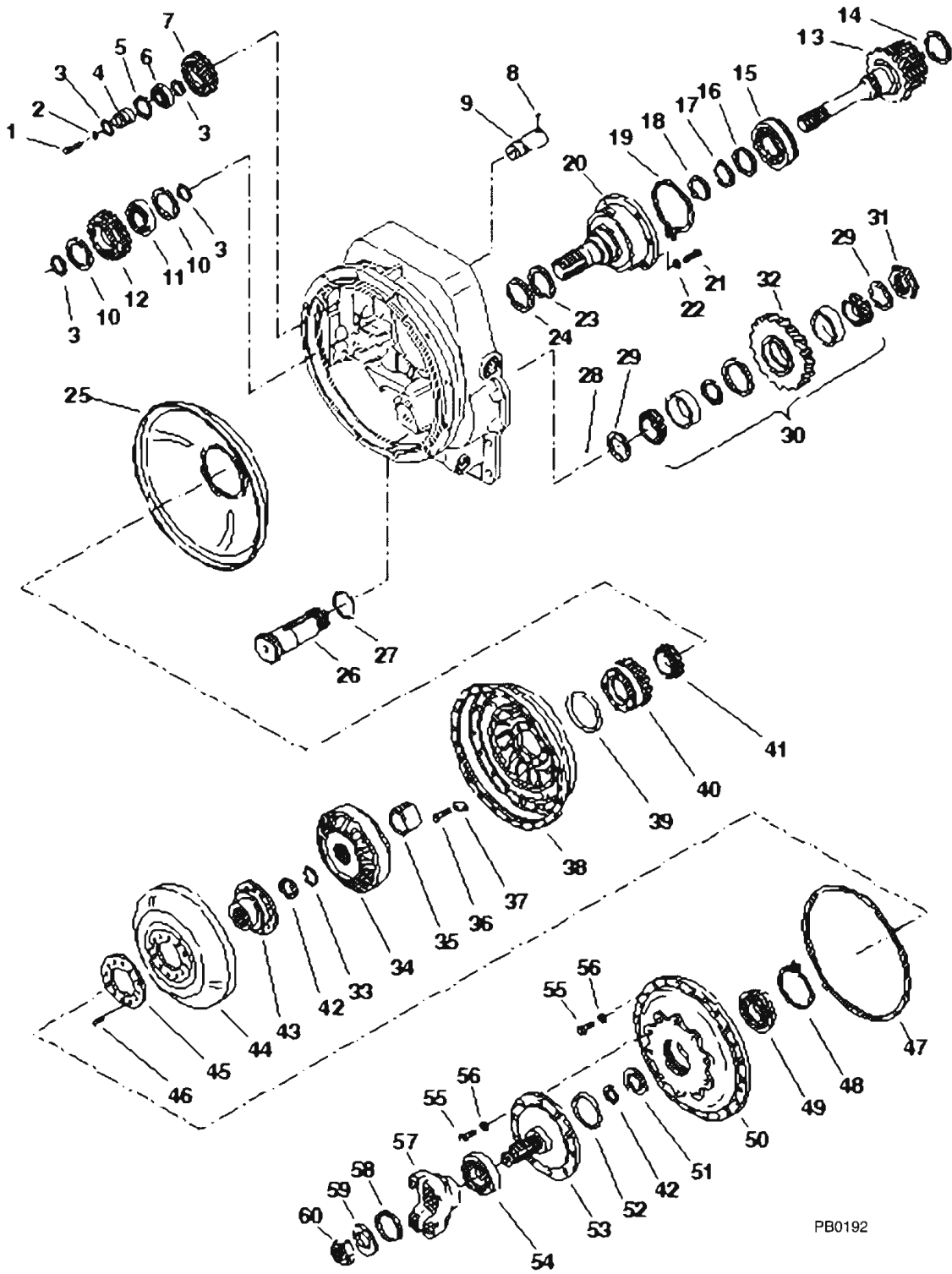

PB0192

SECTION 3 - DRIVE TRAIN

FIGURE 3-2. CONVERTER GROUP (Prior to SN 9909)

ITEM	PART NUMBER	QTY	DESCRIPTION	REV
1	8032541	2	Screw	
2	8307005	2	Washer, Lock	
3	8032545	4	Ring, Locating	
4	8032542	1	Support, Pump Drive Bearing	
5	8032550	1	Ring, Retaining	
6	90204793	1	Bearing, Gear	
7	8032552	1	Pump Drive Gear	
8	8032554	1	Lockball, Stub Shaft	
9	8032555	1	Shaft, Stub	
10	8032543	2	Ring, Retaining	
11	90204788	1	Bearing, Shaft	
12	8032553	1	Pump Drive Idler Gear	
13	8032568	1	Turbine Shaft Assembly (Includes Item 14)	
14	8032620	1	Ring, Retaining	
15	8032567	1	Bearing, Turbine Shaft	
16	8032566	1	Washer, Locating	
17	77104164	1	Ring, Retainer	
18	90204748	1	Ring, Piston	
19	8032563	1	Ring, Snap	
20	8032560	1	Support, Stator	
21	8303620	6	Screw	
22	8307005	6	Washer, Lock	
23	8032559	1	Spring, Expander	
24	8032558	1	Ring, Piston	
25	8032556	1	Oil Baffle Assembly	
26	8033190	1	Shaft, Reverse Idler	
27	8033191	1	O-Ring	
28	8033192	1	Lockball	
29	8033194	2	Plate, Thrust	
30	8032574	1	Reverse Idler Gear Bearing Assembly	
31	8033195	1	Nut, Bearing Retaining Plate	
32	8032573	1	Gear, Reverse Idler	
33	77104031	1	Ring, Retaining	
34	8032579	1	Member, Reaction	
35	8032580	1	Spacer	
36	8032581	8	Screw	
37	77104027	4	LOCK TAB	
38	90204767	1	IMPELLER	
39	8032584	1	O-Ring	
40	8032585	1	Gear, Impeller Hub	
41	8032586	1	Bearing, Impeller Hub Gear	
42	8032587	2	Ring, Retaining	
43	8032588	1	Hub, Turbine	
44	8032589	1	Turbine	
45	8033196	1	Screw Ring, Turbine To Hub	
46	8033197	12	Screw	
47	8032595	1	O-Ring	
48	8032592	1	Locating Ring, Turbine Hub Bearing	
49	8032593	1	Bearing, Turbine Hub	
50	8033384	1	Impeller Cover	

SECTION 3 - DRIVE TRAIN

ITEM	PART NUMBER	QTY	DESCRIPTION	REV
51	8032594	1	Retaining Washer, Bearing	
52	8033385	1	O-Ring	
53	8033386	1	Input Shaft	
54	8033373	1	Bearing, Input Shaft	
55	8303620	34	Screw	
56	8307005	34	Washer	
57	8033885	1	Flange	
58	8033318	1	O-Ring	
59	8032612	1	Washer	
60	8032613	1	Nut	

SECTION 3 - DRIVE TRAIN

FIGURE 3-3. FORWARD, REVERSE, LOW AND 2ND (Prior to SN 9909)

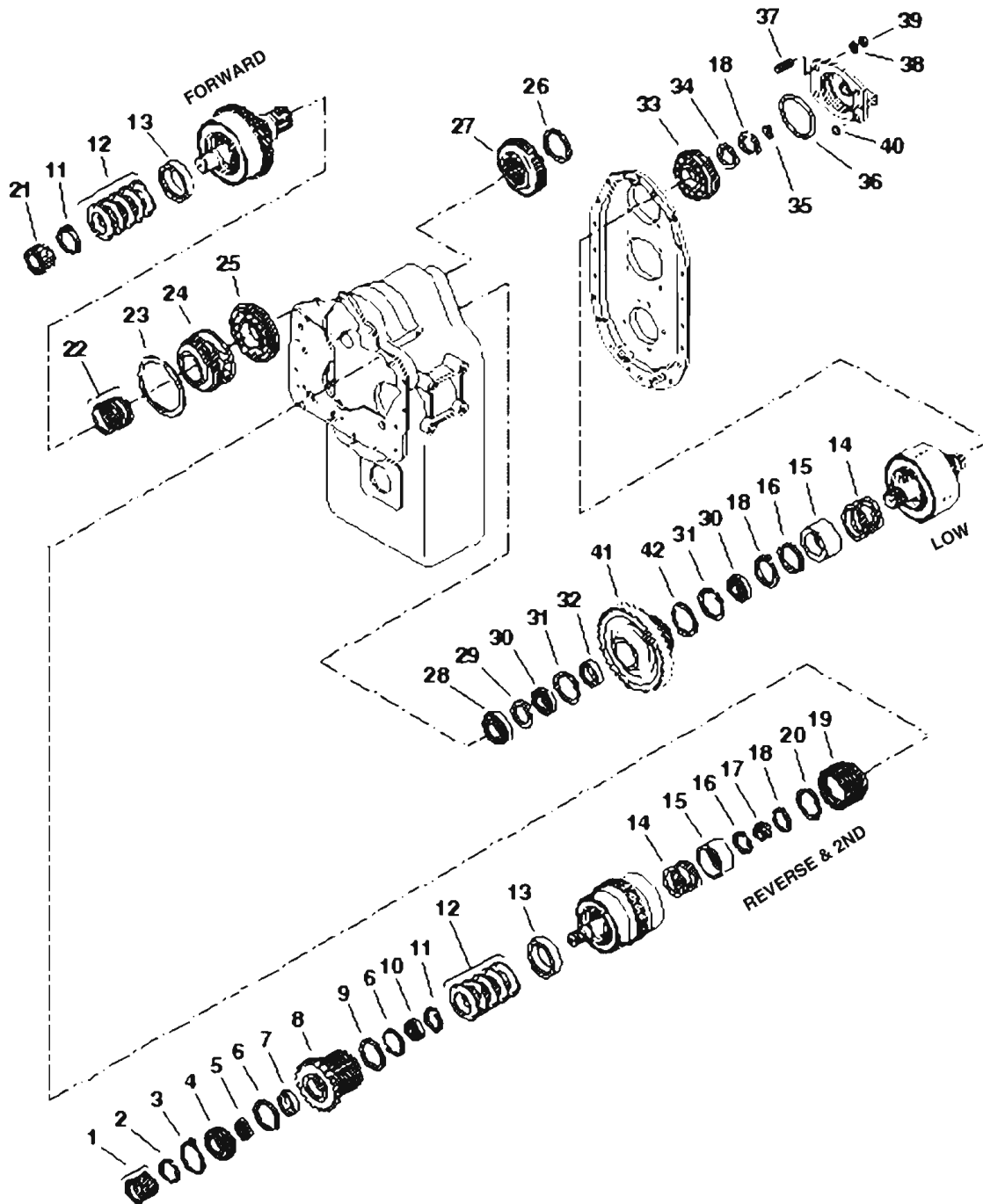

PB0201

SECTION 3 - DRIVE TRAIN

FIGURE 3-3. FORWARD, REVERSE, LOW AND 2ND (Prior to SN 9909)

ITEM	PART NUMBER	QTY	DESCRIPTION	REV
1	8032652	3	Ring, Piston	
2	8032651	1	Ring, Retaining	
3	8032650	1	Snap Ring	
4	8032649	1	Bearing, Front	
5	8032648	1	Bearing, Gear	
6	8032645	2	Ring, Retaining	
7	8032647	1	Spacer, Bearing	
8	8032646	1	Reverse Clutch Gear and Retaining Ring Assembly (Includes Item 9)	
9	8032620	1	Ring, Retaining	
10	8032644	1	Bearing, Gear	
11	8032640	2	Snap Ring	
12	8033348	2	Disc Spring Assembly (Contains 5 Pcs)	
13	8032638	2	Spacer, Piston Return Spring	
14	8032615	2	Piston Return Spring	
15	77104186	2	SPRING RETAINER	
16	10720643	2	Ring, Snap	
17	8032643	1	Bearing, Reverse and 2nd Shaft	
18	8032623	3	Snap Ring	
19	8032642	1	2nd Clutch Disc Hub and Retaining Ring Assembly (Includes Item 20)	
20	8032620	1	Ring, Retaining	
21	8032641	1	Pilot Bearing	
22	8032637	3	Ring, Piston	
23	8033355	1	Ring, Retaining	
24	8032635	1	Sleeve, Piston Ring	
25	77104215	1	Bearing, Forward Shaft	
26	8033356	1	Ring, Retaining	
27	8033357	1	Gear, Forward Shaft	
28	8032633	1	Bearing, Low Speed Clutch	
29	8032632	1	Spacer, Bearing	
30	8032628	2	Bearing, Gear	
31	8032629	2	Locating Ring	
32	8032631	1	Spacer, Gear	
33	8032622	1	Bearing, Low Speed Shaft	
34	8032566	1	Washer, Rear Bearing Support	
35	77104198	1	PISTON RING	
36	8032624	1	O-Ring	
37	8032626	4	Stud, Cap	
38	8032503	4	Washer, Lock	
39	8032506	4	Nut, Stud	
40	8032625	1	O-Ring	
41	8033358	1	Low Shaft Gear, Hub and Retaining Ring Assembly (Includes Item 42)	
42	8032620	1	Ring, Retaining	

SECTION 3 - DRIVE TRAIN

FIGURE 3-4. OUTPUT, IDLER AND THIRD (Prior to SN 9909)

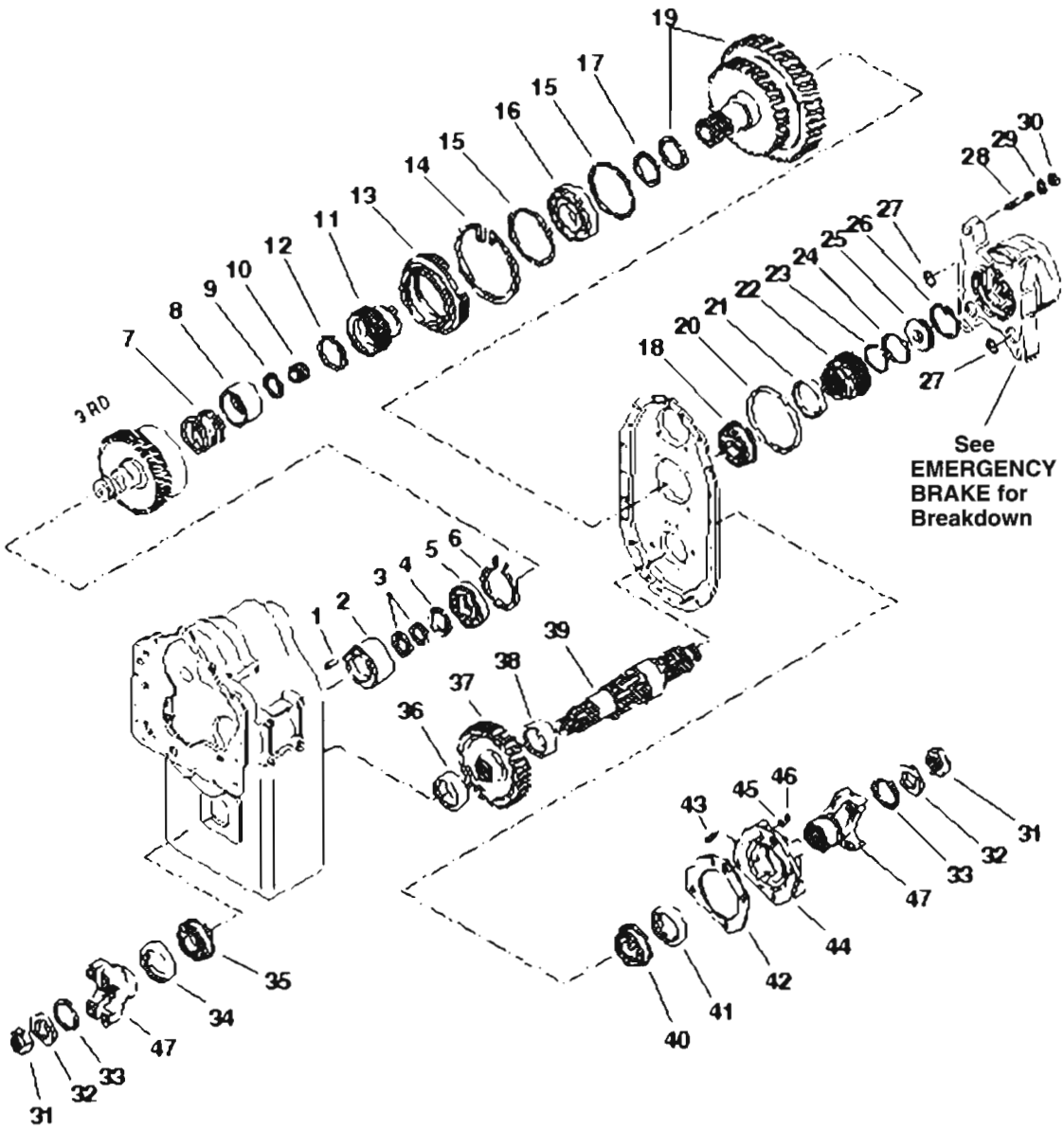

PH0250

SECTION 3 - DRIVE TRAIN

FIGURE 3-4. OUTPUT, IDLER AND THIRD (Prior to SN 9909)

ITEM	PART NUMBER	QTY	DESCRIPTION	REV
1	8033870	1	Roll Pin, Outer Race	
2	8033871	1	Piston Ring Outer Race	
3	8032652	2	Ring, Piston	
4	8033872	1	Ring, Retaining	
5	8032628	1	Bearing	
6	8033351	1	Ring, Locating	
7	8032615	1	Spring, Return	
8	77104186	1	Retainer, Spring	
9	10720643	1	Ring, Snap	
10	8032643	1	Bearing, Pilot	
11	8033359	1	3rd Clutch Disc Hub and Retaining Ring Assembly (Includes Item 12)	
12	8032620	1	Ring, Retaining	
13	8033360	1	Carrier, Bearing	
14	8033361	1	Ring, Locating	
15	8033362	2	Ring, Locating	
16	8033363	1	Bearing, 3rd Clutch Disc Hub	
17	8033364	1	Ring, Retaining	
18	8033365	1	Bearing	
19	8033873	1	Idler Shaft and Gear Assembly (46T)	
20	8033368	1	O-Ring	
21	8033874	1	Seal, Brake Housing To Brake Disc Hub	
22	N.S.S.	1	Hub, Brake Disc	
23	8033876	1	Ring, Snap	
24	8033877	1	O-Ring	
25	8033878	1	Plug, Brake Disc Hub	
26	8033879	1	Ring, Snap	
27	8033880	2	O-Ring	
28	8033881	4	Stud, Brake Housing To Rear Cover	
29	8033882	4	Washer, Lock	
30	8033883	4	Nut, Stud	
31	8033372	2	Nut, Flange	
32	8033371	2	Washer, Flange	
33	8032611	2	O-Ring	
34	8033198	1	Oil Seal, Output Shaft	
35	8033373	1	Bearing	
36	8033376	1	Spacer, Output Gear	
37	8033375	1	Gear, Output Shaft (46T)	
38	8033374	1	Spacer, Output Gear	
39	8033884	1	Shaft, Output	
40	8032604	1	Bearing	
41	8032605	1	Oil Seal, Rear Bearing Cap	
42	8032606	1	Gasket, Rear Bearing Cap	
43	8032627	4	Stud, Bearing Cap	
44	8032607	1	Bearing Cap	
45	8032608	4	Washer, Lock	
46	8032609	4	Nut, Stud	
47	8033885	2	Flange, Output	

SECTION 3 - DRIVE TRAIN

FIGURE 3-5. TRANSMISSION CLUTCH GROUPS (Prior to SN 9909)

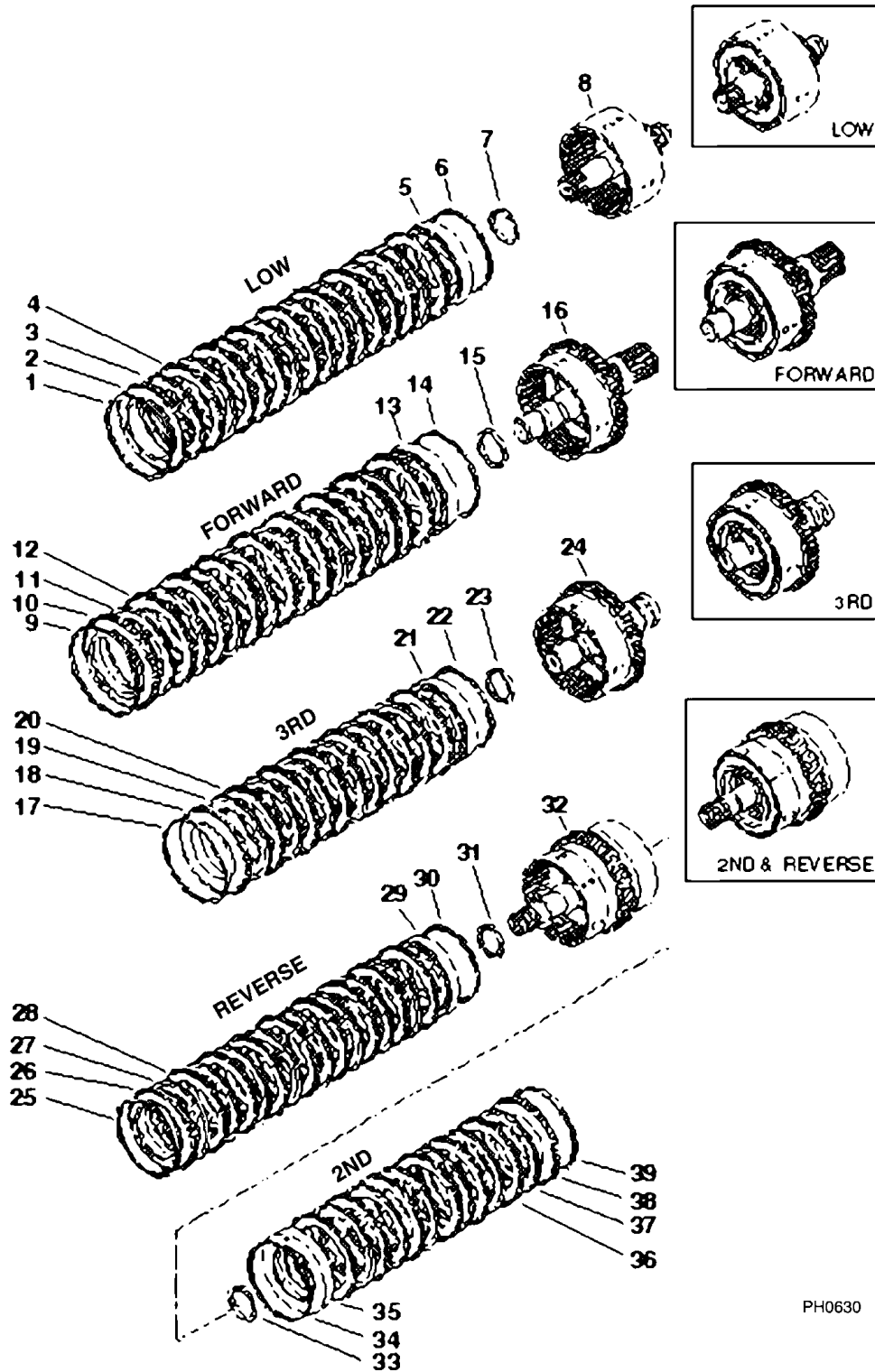

SECTION 3 - DRIVE TRAIN

FIGURE 3-5. TRANSMISSION CLUTCH GROUPS (Prior to SN 9909)

ITEM	PART NUMBER	QTY	DESCRIPTION	REV
1	8032653	1	Ring, Snap	
2	8032654	1	Backing Plate	
3	8032655	8	Disc, Clutch Inner	
4	8032656	8	Disc, Clutch Outer	
5	8032657	1	Piston, Clutch	
6	8032658	1	Ring, Outer Piston	
7	8032659	1	Seal, Inner Piston	
8	8033387	1	Low Clutch Shaft Drum and Bleed Valve Assembly	
9	8032653	1	Ring, Snap	
10	8032654	1	Backing Plate	
11	8032661	8	Disc, Clutch Inner	
12	8032656	8	Disc, Clutch Outer	
13	8032657	1	Piston, Clutch	
14	8032658	1	Ring, Outer Piston	
15	8032659	1	Seal, Inner Piston	
16	8033347	1	Forward Shaft, Drum and Plug Assembly	
17	8032653	1	Ring, Snap	
18	8032654	1	Backing Plate	
19	8032661	6	Disc, Clutch Inner	
20	8032656	6	Disc, Clutch Outer	
21	8032663	1	Clutch Piston Assembly	
22	8032658	1	Ring, Outer Piston	
23	8032659	1	Seal, Inner Piston	
24	8033344	1	3rd Clutch Shaft, Drum and Plug Assembly	
25	8032653	1	Ring, Snap	
26	8032654	1	Backing Plate	
27	8032661	8	Disc, Clutch Inner	
28	8032656	8	Disc, Clutch Outer	
29	8032657	1	Piston, Clutch	
30	8032658	1	Ring, Outer Piston	
31	8032659	1	Seal, Inner Piston	
32	8032665	1	Rev and 2nd Shaft, Drum and Plug Assembly	
33	8032659	1	Seal, Inner Piston	
34	8032658	1	Ring, Outer Piston	
35	8032663	1	Piston, Clutch	
36	8032656	6	Disc, Clutch Outer	
37	8032661	6	Disc, Clutch Inner	
38	8032654	1	Backing Plate	
39	8032653	1	Ring, Snap	

SECTION 3 - DRIVE TRAIN

FIGURE 3-6. CONTROL VALVE ASSEMBLY (Prior to SN 9909)

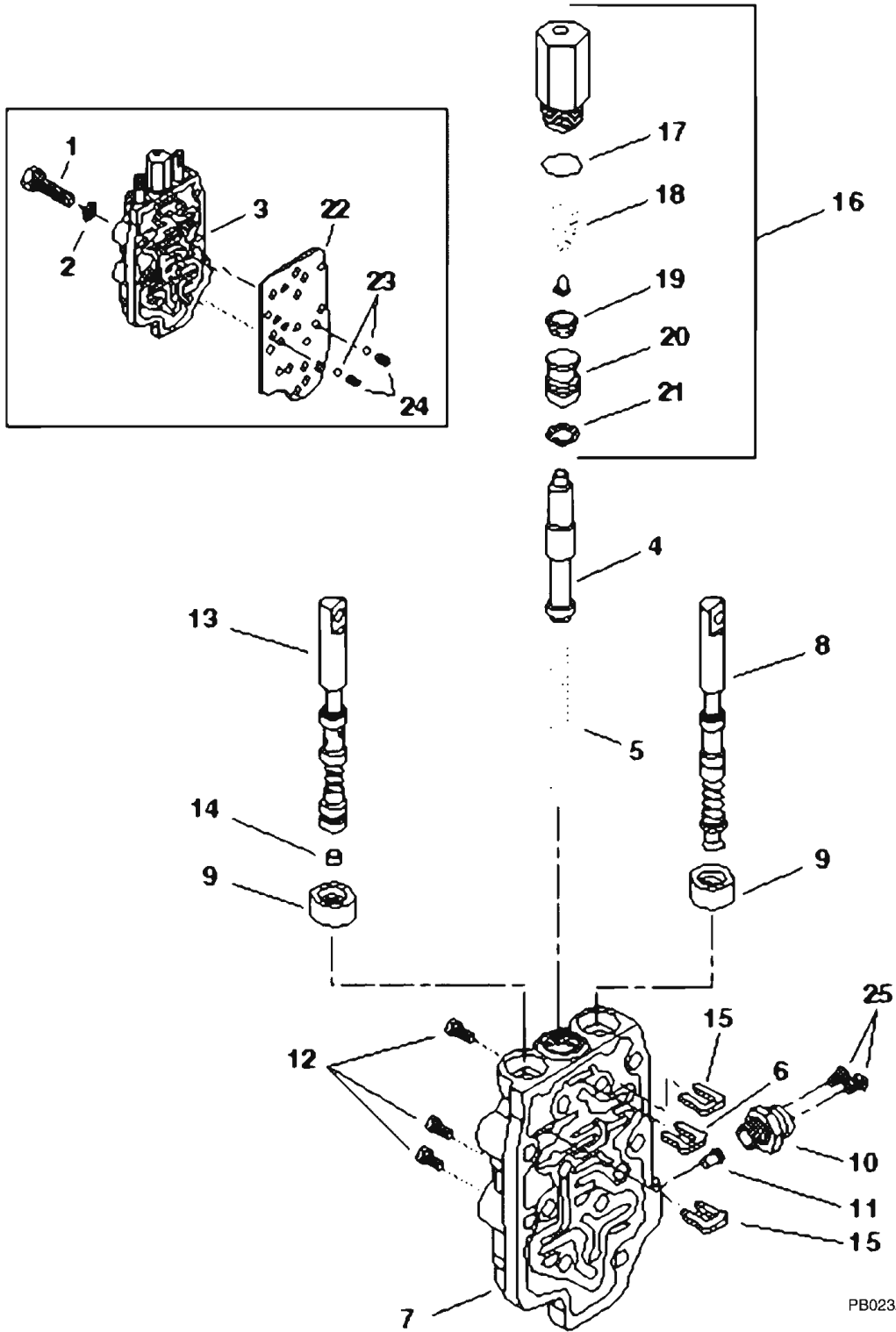

PB0232

SECTION 3 - DRIVE TRAIN

FIGURE 3-6. CONTROL VALVE ASSEMBLY (Prior to SN 9909)

ITEM	PART NUMBER	QTY	DESCRIPTION	REV
1	8032666	9	Screw	
2	8307005	9	Washer, Lock	
3	8033239	1	Control Valve Assembly (Includes Items 4 thru 7 and Item 16)	
4	8032672	1	Valve Spool	
5	8032673	1	Spring, Control Valve	
6	8032676	1	Stop, Valve Spool	
7	8032679	1	Control Valve Housing Assembly (Includes Items 8 thru 15)	
8	8032674	1	Valve Spool, Forward and Reverse	
9	8032675	2	Oil Seal	
10	8825174	1	Switch, Neutral	
11	8032678	1	Switch Actuating Pin	
12	8032680	3	Pipe Plug	
13	8032682	1	Speed Selector Spool and Plug Assembly (Includes Item 14)	
14	8032681	1	Plug	
15	8032676	2	Stop, Valve Spool	
16	8841314	1	Hydraulic Actuator Assembly (Includes Items 17 thru 21)	
17	8033202	1	O-Ring	
18	8033203	1	Balance Spring and Pin Kit	
19	8033204	1	Piston Seal	
20	8033205	1	Piston	
21	8033238	1	Glyd Ring Assembly	
22	8033890	1	Gasket, Control Valve	
23	77104284	2	DETENT BALL	
24	8032670	2	Detent Spring	
25	8303987	2	Screw, #8-32 x 1/4in Slotted Pan Hd	

SECTION 3 - DRIVE TRAIN

FIGURE 3-7. EMERGENCY BRAKE (Prior to SN 9909)

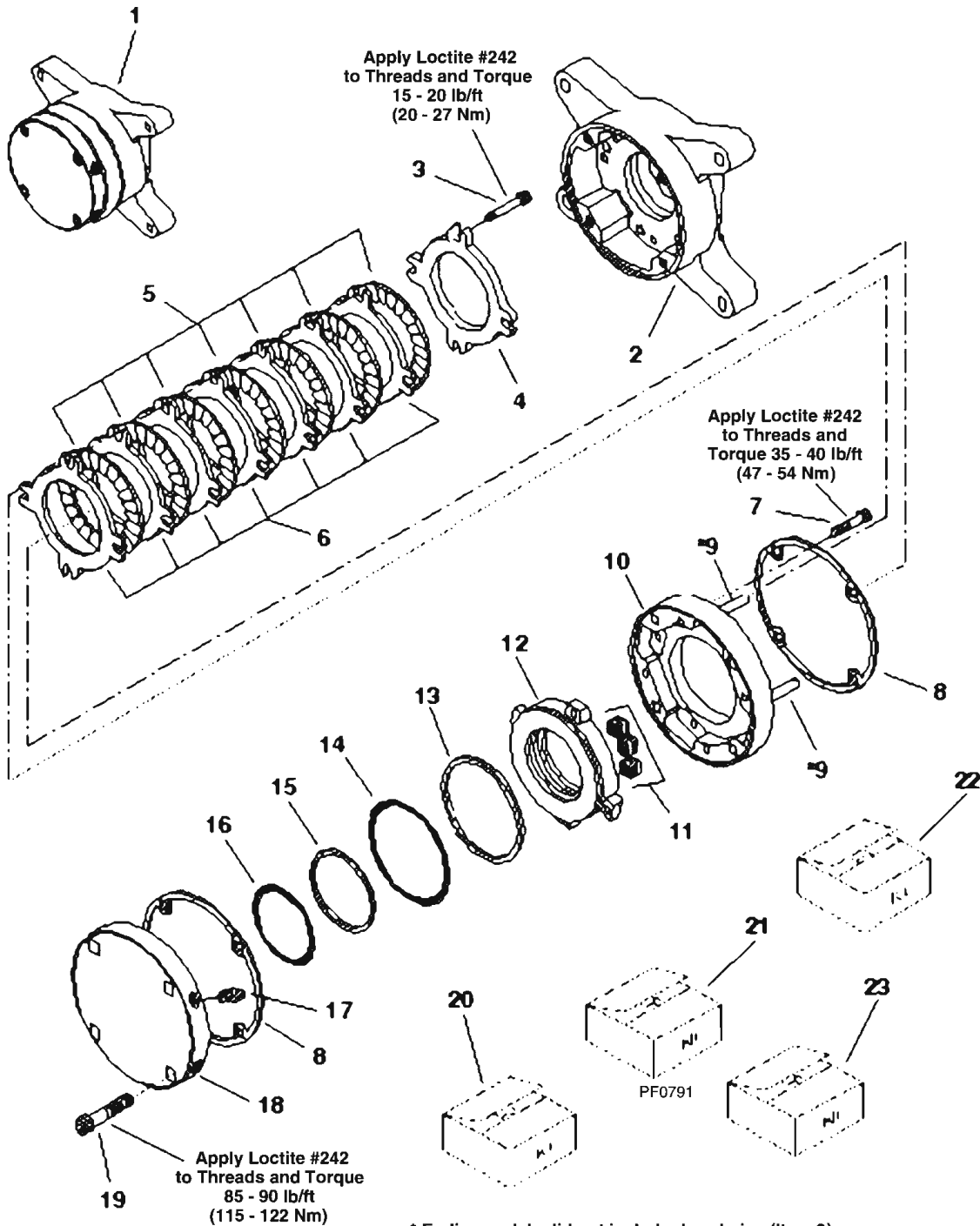

* Earlier models did not include dowel pins (Item 9). For earlier models, all tabs on stator discs (Item 6) must line up over shoulder bolts (Item 3).

PH0131

SECTION 3 - DRIVE TRAIN

FIGURE 3-7. EMERGENCY BRAKE (Prior to SN 9909)

ITEM	PART NUMBER	QTY	DESCRIPTION	REV
1	8033791	1	Emergency Brake Assembly (Includes Items 2 thru 19)	
2	8033774	1	Cover	
3	8033775	4	Shoulder Bolt	
4	See Kits	1	Disc, Primary	
5	See Kits	7	Disc, Rotor	
6	See Kits	7	Disc, Stator	
7	8033776	4	HHCS, Socket Head	
8	See Kits	2	Case Gasket	
9	8033777	4	Dowel Pin	
10	8033778	1	Spring Plate	
11	See Kits	12	Spring, Red	
12	8033779	1	Piston	
13	See Kits	1	Back-up Ring	
14	See Kits	1	O-Ring	
15	See Kits	1	Back-up Ring	
16	See Kits	1	O-Ring	
17	8033780	1	Bleeder Screw	
18	8033781	1	Pressure Plate	
19	8033782	4	HHCS, Socket Head	
		Ref	KITS	
20	7131852	1	Kit, Repair Park Brake (Includes Items 3, 21, 22 & 23)	
21	8033771	1	Rotor and Stator Disc Kit (Includes Items 4 thru 6 & 8)	
22	8033772	1	O-Ring and Back-up Ring Kit (Includes Items 8 & 13 thru 16)	
23	8033773	1	Spring Kit (Includes Items 8 & 11)	

SECTION 3 - DRIVE TRAIN

FIGURE 3-8. TRANSMISSION MOUNTING (Prior to SN 9909)

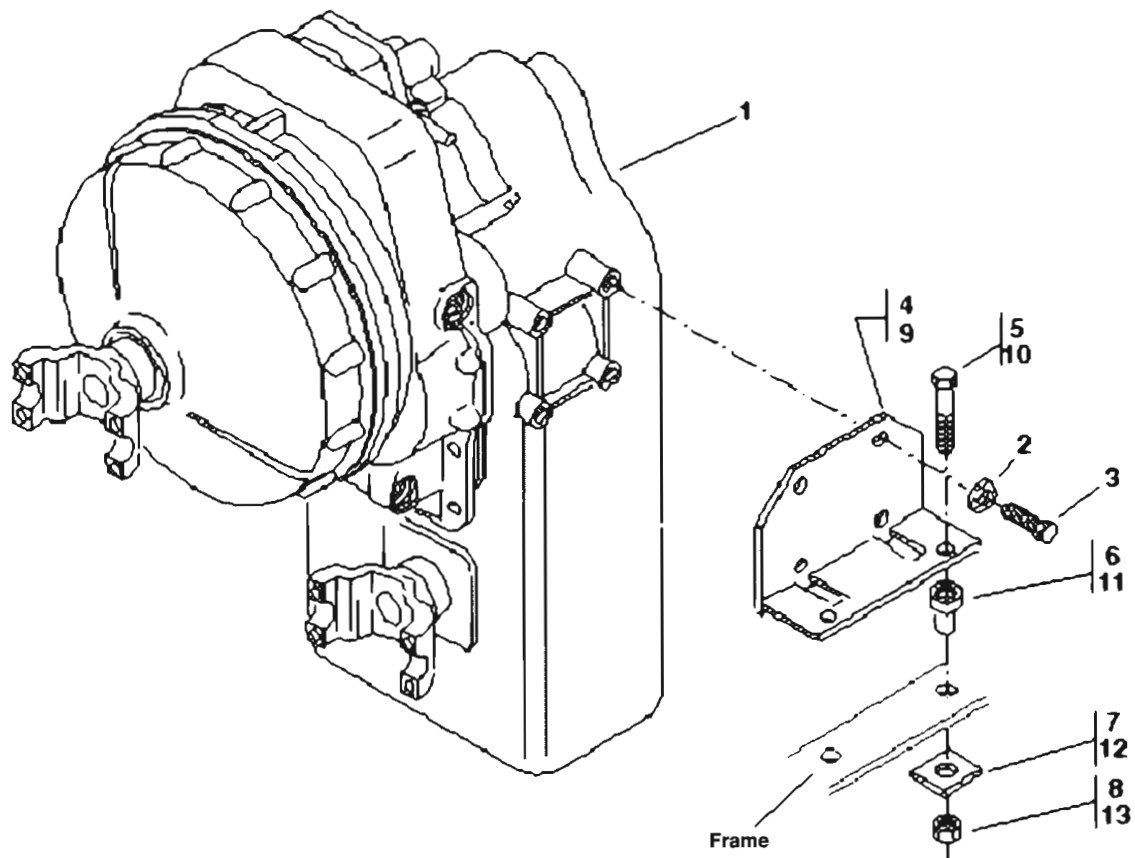

PH0241

SECTION 3 - DRIVE TRAIN

FIGURE 3-8. TRANSMISSION MOUNTING (Prior to SN 9909)

ITEM	PART NUMBER	QTY	DESCRIPTION	REV
1	8841025	1	Transmission	
2	8307010	8	Washer, Lock 3/4in	
3	8303664	8	HHCS, 3/4-10 x 1-1/2in	
4	7095342	2	Mount, Transmission (Machines Model 8042 Prior to SN 0059) (Machines Model 10042 Prior to SN 0058)	
5	8310051	4	HHCS, 1-8 x 4in (Machines Model 8042 Prior to SN 0059) (Machines Model 10042 Prior to SN 0058)	
6	8278017	4	Isolator (Machines Model 8042 Prior to SN 8042-0059) (Machines Model 10042 Prior to SN 10042-0058)	
7	7096471	4	Washer, Rebound (Machines Model 8042 Prior to SN 0059) (Machines Model 10042 Prior to SN 0058)	
8	8310116	4	Nut, Hex Lock Elastic 1-8 (Machines Model 8042 Prior to SN 0059) (Machines Model 10042 Prior to SN 0058)	
9	7111952	2	Mount, Transmission (For Machines Model 8042 SN 0059 thru 9908) (For Machines Model 10042 SN 0058 thru 9908) (For Machines Model 10054)	
10	8303724	4	HHCS, 3/4-10 x 3-1/2in (For Machines Model 8042 SN 0059 thru 9908) (For Machines Model 10042 SN 0058 thru 9908) (For Machines Model 10054)	
11	8278007	4	Isolator (For Machines Model 8042 SN 0059 thru 9908) (For Machines Model 10042 SN 0058 thru 9908) (For Machines Model 10054)	
12	7054351	4	Washer, Rebound (For Machines Model 8042 SN 0059 thru 9908) (For Machines Model 10042 SN 0058 thru 9908) (For Machines Model 10054)	
13	8310067	4	Nut, Hex Lock Elastic 3/4in (For Machines Model 8042 SN 0059 thru 9908) (For Machines Model 10042 SN 0058 thru 9908) (For Machines Model 10054)	

SECTION 3 - DRIVE TRAIN

FIGURE 3-9. ENGINE CONNECT (SN 9909 through 13197)

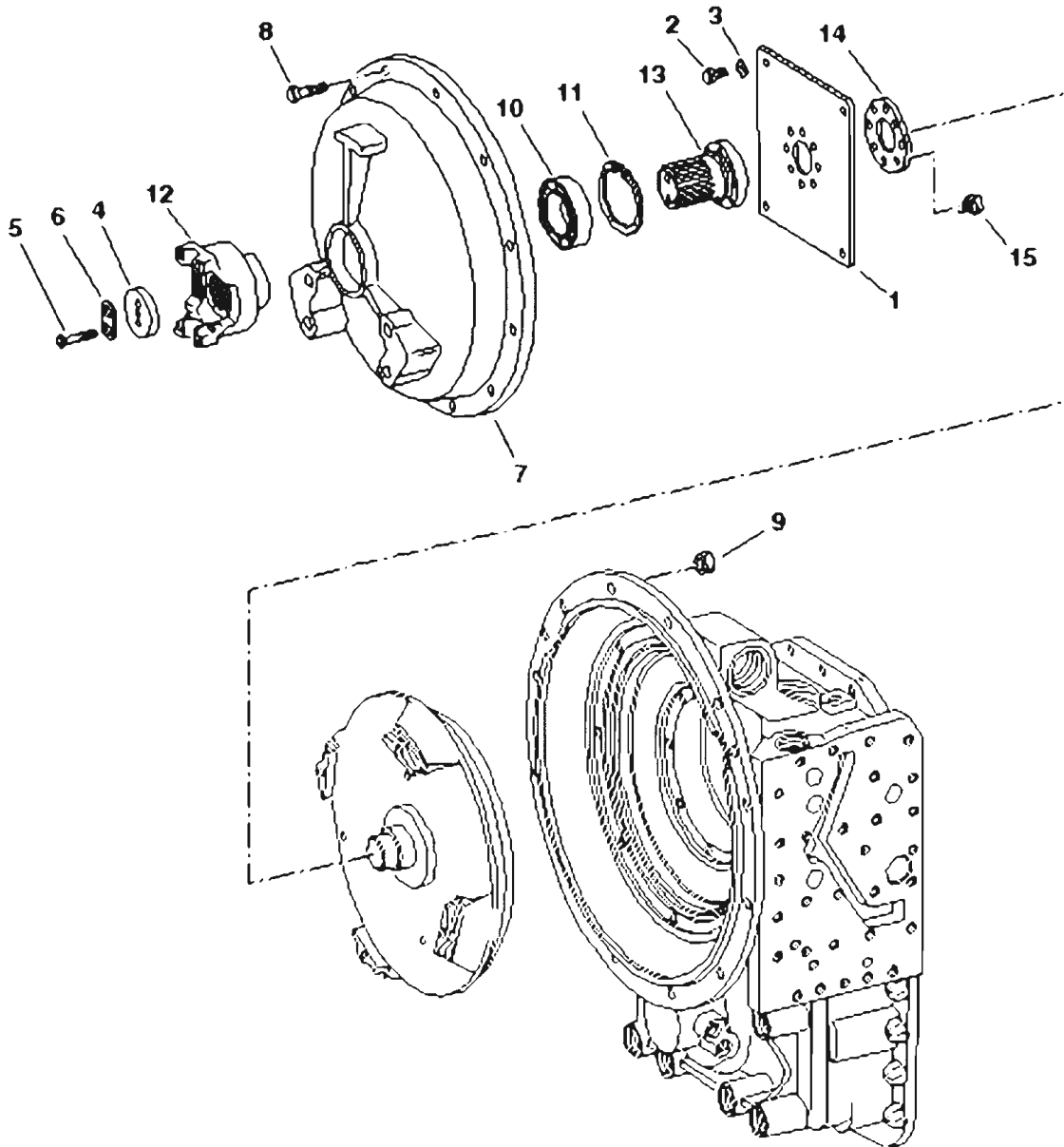

PH1040

SECTION 3 - DRIVE TRAIN

FIGURE 3-9. ENGINE CONNECT (SN 9909 through 13197)

ITEM	PART NUMBER	QTY	DESCRIPTION	REV
1	1319203	1	Diaphragm	
2	1319204	4	HHCS, M10 x 18mm	
3	10732095	4	Washer, 10,5	
4	1319205	1	Washer	
5	1319206	2	HHCS, M8 x 50mm	
6	1319207	1	Washer	
7	1319208	1	Cover	
8	10731748	12	HHCS, M10 x 45mm	
9	10731751	12	Nut, Hex M10	
10	1319209	1	Bearing	
11	1319210	1	Ring, Retaining 90 x 3	
12	1319211	1	Flange, Input	
13	1319212	1	Shaft, Input	
14	1319213	1	Washer	
15	10731702	8	HHCS, M10 x 16mm	

SECTION 3 - DRIVE TRAIN

FIGURE 3-10. CONVERTER AND LAYSHAFT (SN 9909 through 13197)

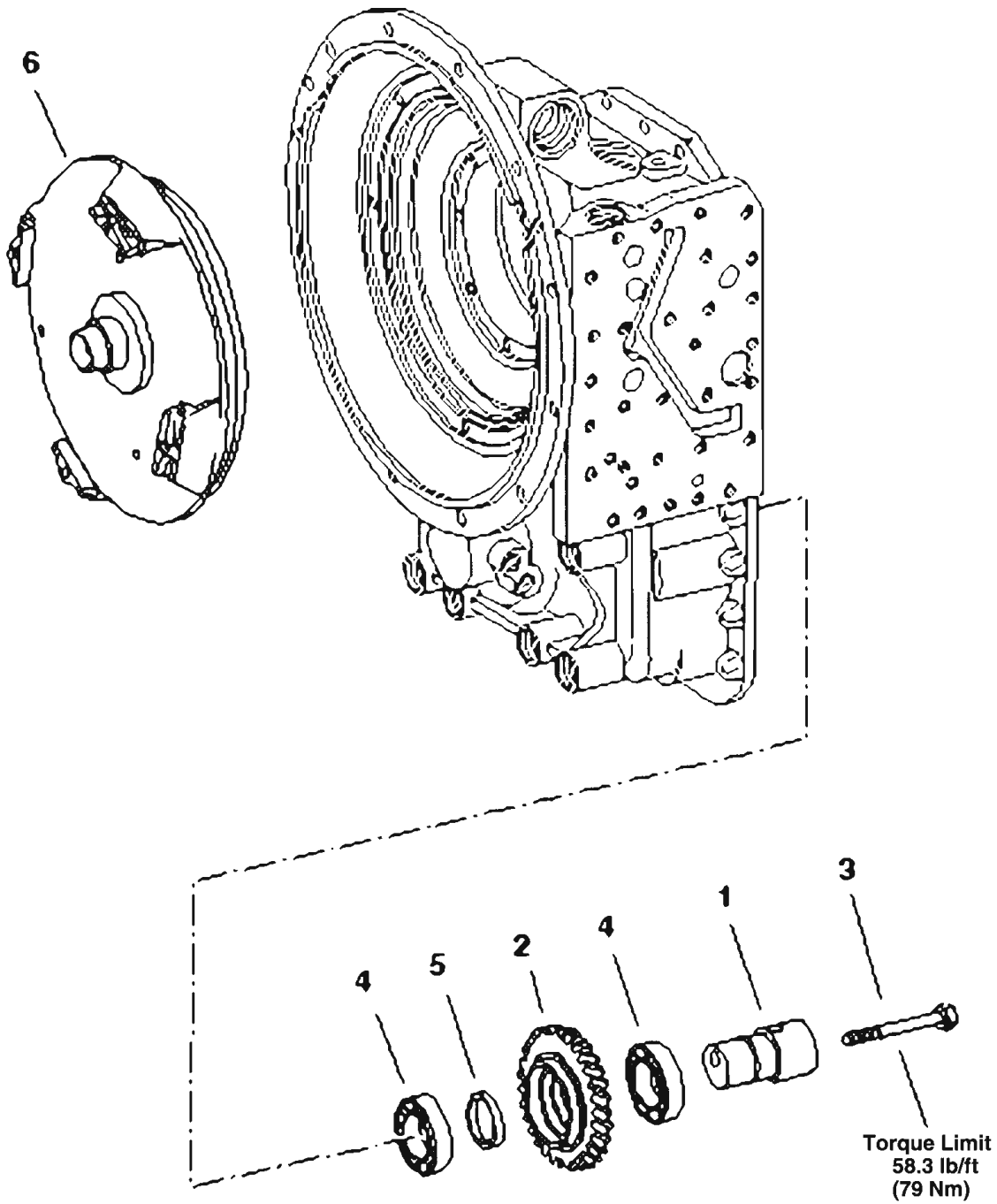

PH1050

SECTION 3 - DRIVE TRAIN

FIGURE 3-10. CONVERTER AND LAYSHAFT (SN 9909 through 13197)

ITEM	PART NUMBER	QTY	DESCRIPTION	REV
1	10732110	1	Axle	
2	10732111	1	Gear, Idler	
3	10732112	1	HHCS, M12 x 115mm	
4	10732113	2	Bearing, Roller	
5	10732114	1	Bushing, 7,20mm	
5	10732115	1	Bushing, 7,25mm	
5	10732116	1	Bushing, 7,30mm	
5	10732117	1	Bushing, 7,35mm	
5	10732118	1	Bushing, 7,40mm	
5	10732119	1	Bushing, 7,45mm	
5	10732120	1	Bushing, 7,50mm	
5	10732121	1	Bushing, 7,55mm	
5	10732122	1	Bushing, 7,60mm	
6	10731704	1	Converter	

SECTION 3 - DRIVE TRAIN

FIGURE 3-11. OIL PRESSURE PUMP (SN 9909 through 13197)

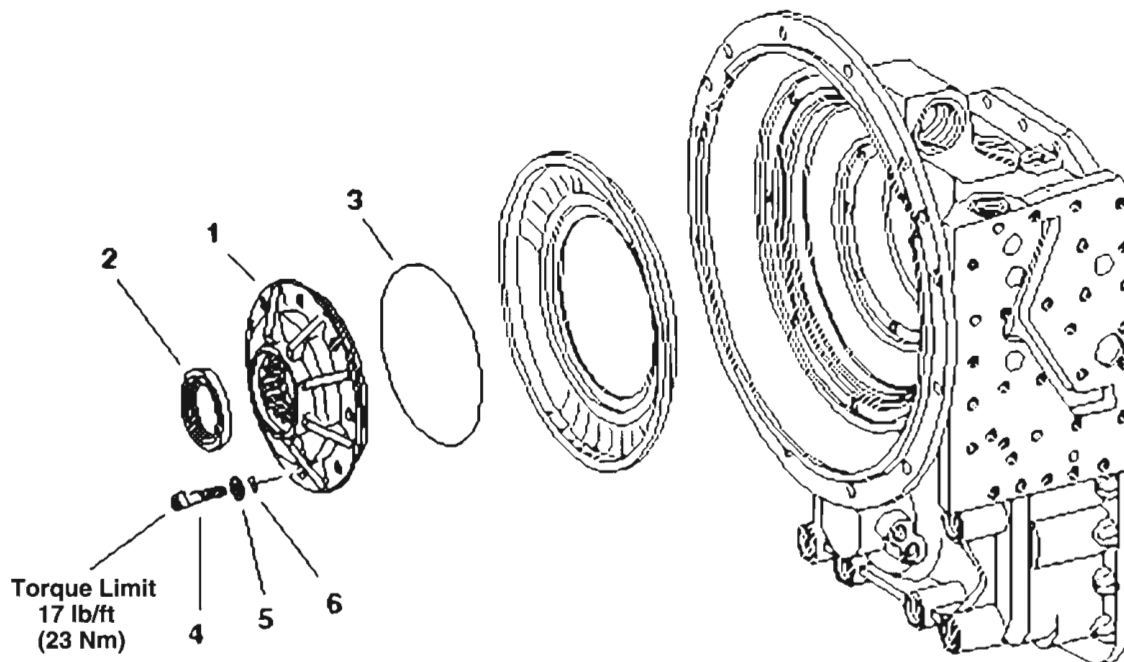

PH1060

SECTION 3 - DRIVE TRAIN

FIGURE 3-11. OIL PRESSURE PUMP (SN 9909 through 13197)

ITEM	PART NUMBER	QTY	DESCRIPTION	REV
1	10731705	1	Pump	
2	10731706	1	Seal, Shaft	
3	10731707	1	O-Ring, 192 x 3	
4	1319214	8	SHCS, M8 x 40mm	
5	10731710	8	Washer, 8,4	
6	10731709	8	O-Ring, 8 x 1,5	

SECTION 3 - DRIVE TRAIN

FIGURE 3-12. INPUT SHAFT (SN 9909 through 13197)

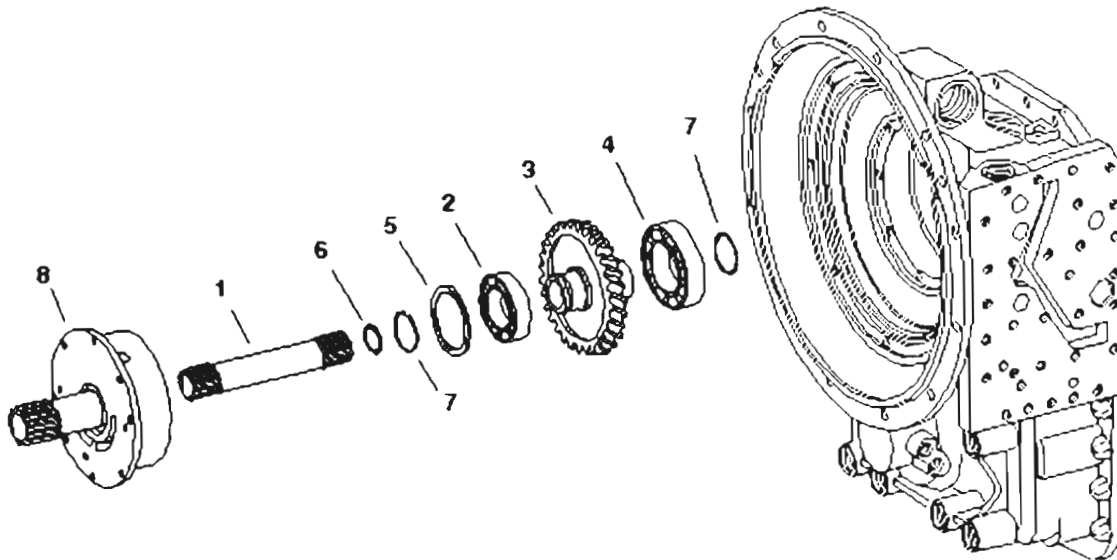

PH1070

SECTION 3 - DRIVE TRAIN

FIGURE 3-12. INPUT SHAFT (SN 9909 through 13197)

ITEM	PART NUMBER	QTY	DESCRIPTION	REV
1	10731711	1	Shaft, Turbine	
2	10731712	1	Bearing, Roller	
3	10731713	1	Gear, Input	
4	1319215	1	Bearing, Roller	
5	10731715	1	Washer, 1,2mm	
5	1319216	1	Washer, 1,25mm	
5	1319217	1	Washer, 1,35mm	
5	10731716	1	Washer, 0,5mm	
5	10731717	1	Washer, 0,6mm	
5	10731718	1	Washer, 0,7mm	
5	10731719	1	Washer, 0,8mm	
5	10731720	1	Washer, 0,9mm	
5	10731721	1	Washer, 1,0mm	
5	10731722	1	Washer, 1,1mm	
5	10731723	1	Washer, 1,3mm	
5	10731724	1	Washer, 1,4mm	
5	10731725	1	Washer, 1,5mm	
5	10731726	1	Washer, 0,65mm	
5	10731727	1	Washer, 0,75mm	
5	10731728	1	Washer, 0,85mm	
5	10731729	1	Washer, 0,95mm	
5	10731730	1	Washer, 1,05mm	
5	10731731	1	Washer, 1,15mm	
6	10731732	1	Ring, Snap	
7	1319218	2	Ring, Piston	
8	10731734	1	Flange, Oil Feed	

SECTION 3 - DRIVE TRAIN

FIGURE 3-13. GEARBOX HOUSING (SN 9909 through 13197)

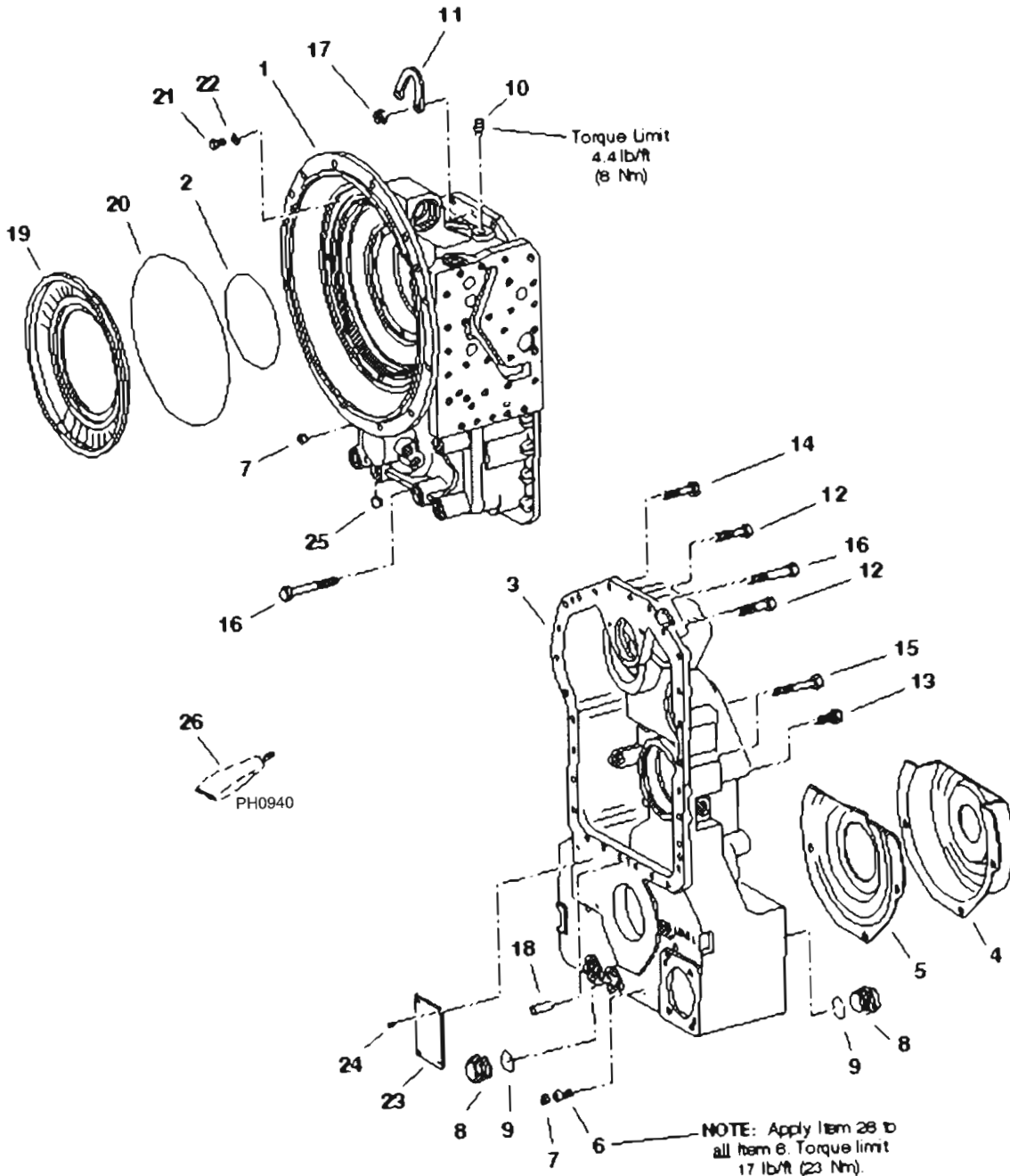

PH1080

SECTION 3 - DRIVE TRAIN

FIGURE 3-13. GEARBOX HOUSING (SN 9909 through 13197)

ITEM	PART NUMBER	QTY	DESCRIPTION	REV
1	1319219	1	Housing	
2	10731736	1	O-Ring, 150 x 3	
3	10731737	1	Housing, Gearbox	
4	10731738	1	Sheet, Screen	
5	10731739	1	Sheet, Screen	
6	1319220	3	SHCS, M8 x 35mm	
7	10731741	5	Cap, Sealing	
8	10731742	2	Plug, M33 x 2	
9	10731743	2	O-Ring, 30 x 2,5	
10	10731744	1	Breather	
11	10731745	1	Bracket	
12	10731746	3	HHCS, M10 x 55mm	
13	10731747	17	HHCS, M10 x 32mm	
14	10731748	3	HHCS, M10 x 45mm	
15	10731749	2	HHCS, M10 x 85mm	
16	10731750	3	HHCS, M10 x 70mm	
17	10731751	6	Nut, Hex M10	
18	10731752	1	Pin, M6 x 35mm	
19	10731753	1	Sheet, Cover	
20	10731754	1	O-Ring, 294 x 3	
21	1319221	8	HHCS, M8 x 20mm	
22	10731756	8	Washer, M8	
23	1319222	1	Plate, Type	
24	1319573	4	GROOVED STUD, 3X5	
25	10731759	1	Ball	
26	8526052	AR	Threadlocker, High Strength	

SECTION 3 - DRIVE TRAIN

FIGURE 3-14. CLUTCH PACK 1ST GEAR - 1 OF 2 (SN 9909 through 13197)

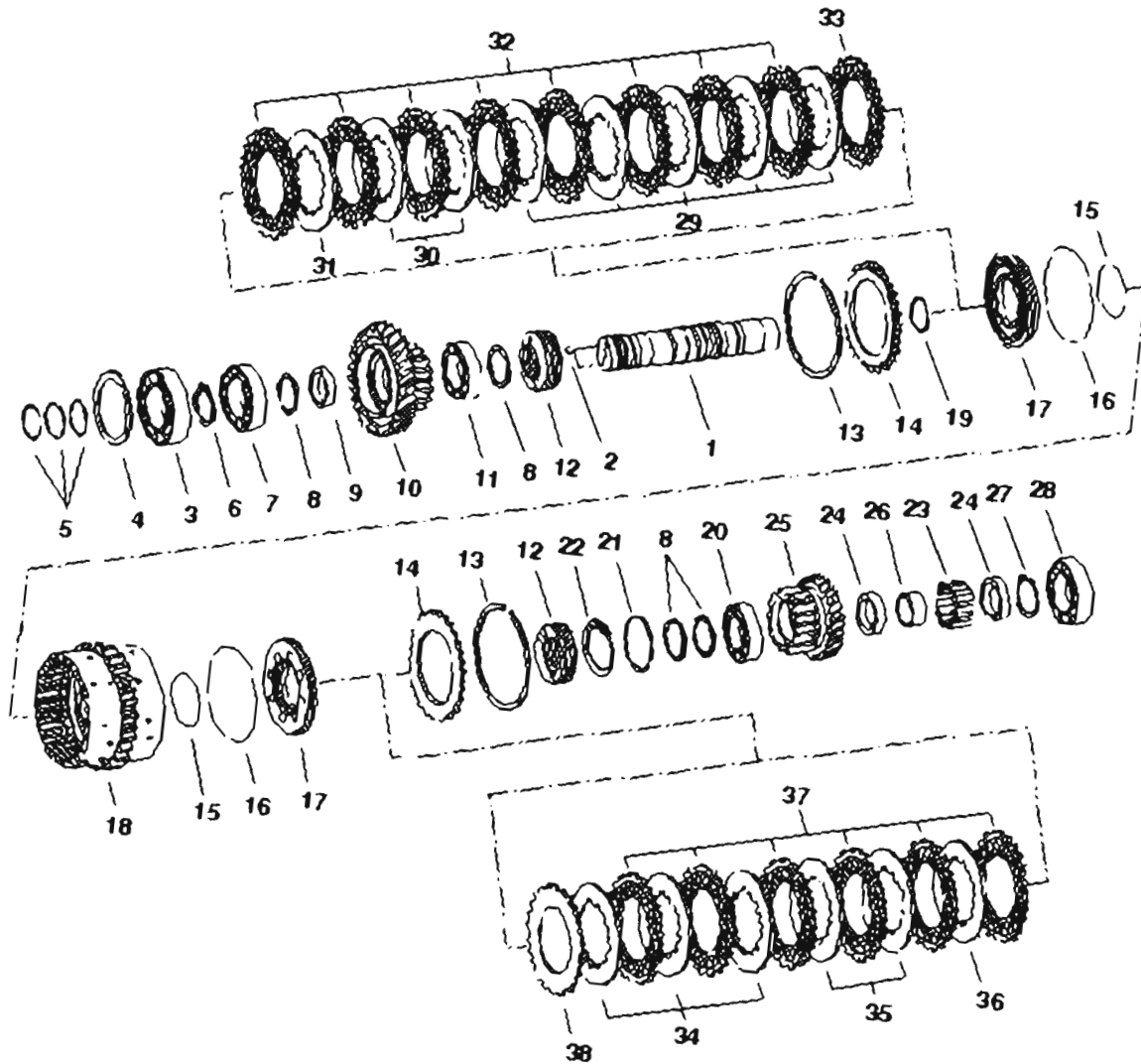

PH1100

SECTION 3 - DRIVE TRAIN

FIGURE 3-14. CLUTCH PACK 1ST GEAR - 1 OF 2 (SN 9909 through 13197)

ITEM	PART NUMBER	QTY	DESCRIPTION	REV
1	1319223	1	Shaft	
2	10731761	2	Ball	
3	10731762	1	Bearing, Ball	
4	10731763	1	Shim, 0,9mm	
4	10731764	1	Shim, 0,95mm	
4	10731765	1	Shim, 1,00mm	
4	10731766	1	Shim, 1,05mm	
4	10731767	1	Shim, 1,1mm	
4	10731768	1	Shim, 1,15mm	
4	10731769	1	Shim, 1,2mm	
4	10731770	1	Shim, 1,25mm	
4	10731771	1	Shim, 1,3mm	
4	10731772	1	Shim, 1,35mm	
4	10731773	1	Shim, 1,4mm	
4	10731774	1	Shim, 1,45mm	
4	10731775	1	Shim, 1,5mm	
4	10731776	1	Shim, 1,55mm	
4	10731777	1	Shim, 1,6mm	
4	10731778	1	Shim, 1,65mm	
4	10731779	1	Shim, 1,7mm	
4	10731780	1	Shim, 1,75mm	
4	10731781	1	Shim, 1,8mm	
4	10731782	1	Shim, 1,85mm	
4	10731783	1	Shim, 1,9mm	
4	10731784	1	Shim, 1,95mm	
4	10731785	1	Shim, 2,0mm	
4	10731786	1	Shim, 2,05mm	
4	10731787	1	Shim, 2,1mm	
4	1319285	1	Shim, 2,15mm	
4	1319286	1	Shim, 2,2mm	
4	1319287	1	Shim, 2,25mm	
4	1319288	1	Shim, 2,3mm	
5	1319224	3	Ring, Piston 45 x 2,5	
6	10731789	1	Ring, Retaining 45 x 1,75	
7	10731790	1	Bearing, Ball	
8	10731791	4	Shim, 1,3mm	
8	10731792	4	Shim, 1,35mm	
8	10731793	4	Shim, 1,4mm	
8	10731794	4	Shim, 1,45mm	
8	10731795	4	Shim, 1,5mm	
8	10731796	4	Shim, 1,55mm	
8	10731797	4	Shim, 1,6mm	
8	10731798	4	Shim, 1,65mm	
8	10731799	4	Shim, 1,7mm	
8	10731800	4	Shim, 1,75mm	
8	10731801	4	Shim, 1,8mm	
8	10731802	4	Shim, 1,85mm	
8	10731803	4	Shim, 1,9mm	
8	10731804	4	Shim, 1,95mm	
8	10731805	4	Shim, 2,0mm	

SECTION 3 - DRIVE TRAIN

ITEM	PART NUMBER	QTY	DESCRIPTION	REV
8	10731806	4	Shim, 2,05mm	
8	10731807	4	Shim, 2,1mm	
8	10731808	4	Shim, 2,15mm	
8	10731809	4	Shim, 2,2mm	
8	10731810	4	Shim, 2,25mm	

SECTION 3 - DRIVE TRAIN

FIGURE 3-15. CLUTCH PACK 1ST GEAR - 2 OF 2 (SN 9909 through 13197)

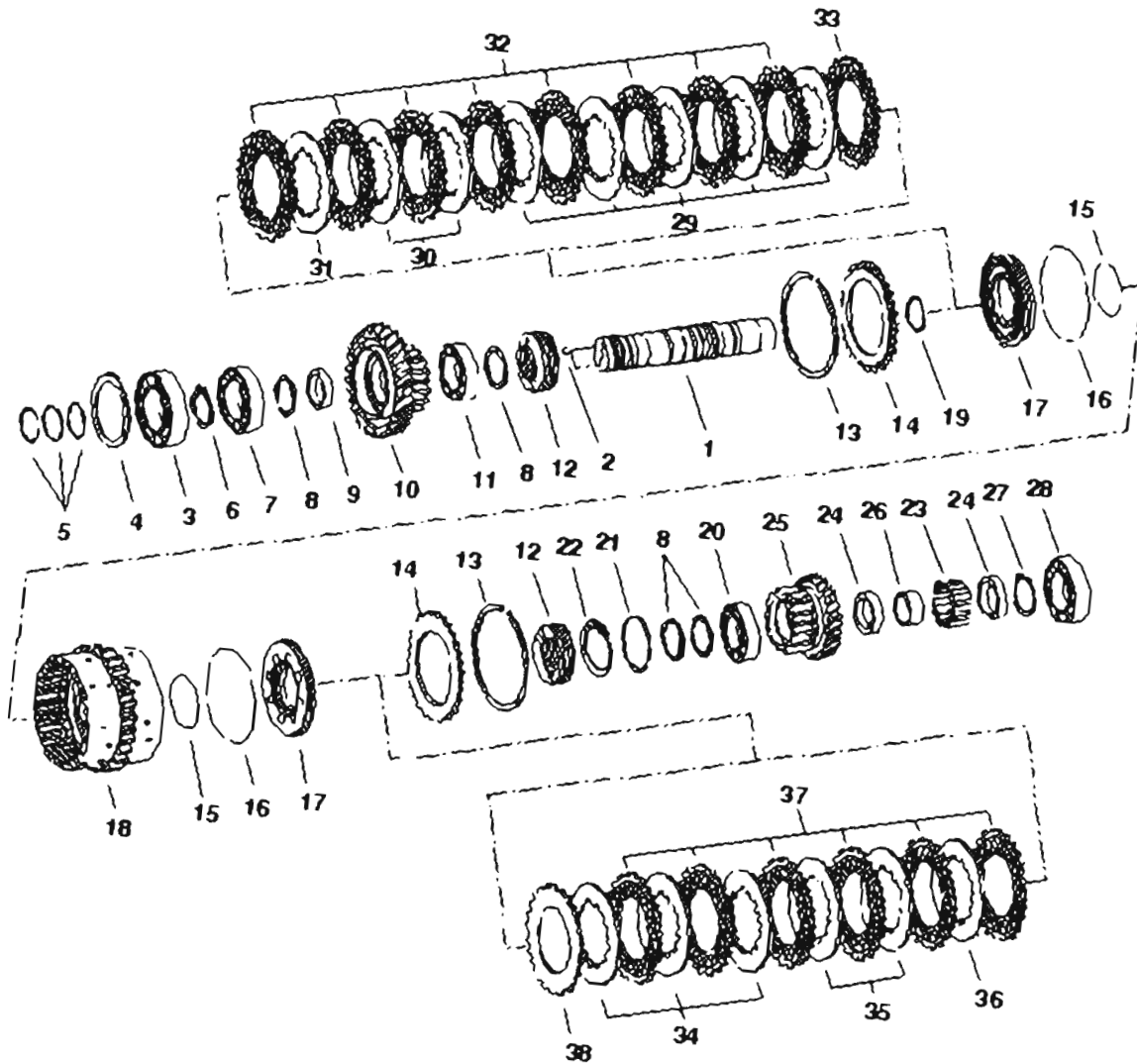

PH1100

SECTION 3 - DRIVE TRAIN

FIGURE 3-15. CLUTCH PACK 1ST GEAR - 2 OF 2 (SN 9909 through 13197)

ITEM	PART NUMBER	QTY	DESCRIPTION	REV
8	10731811	4	Shim, 2,3mm	
8	10731812		Shim, 2,35mm	
8	10731813	4	Shim, 2,4mm	
8	10731814	4	Shim, 2,45mm	
8	10731815	4	Shim, 2,5mm	
8	10731816	4	Shim, 2,55mm	
8	10731817	4	Shim, 2,6mm	
8	10731818	4	Shim, 2,65mm	
8	10731819	4	Shim, 2,7mm	
8	10731820	4	Shim, 2,75mm	
8	10731821	4	Shim, 2,8mm	
9	10731822	1	Bush	
10	10731823	1	Gear, Spur Z=44	
11	10731824	1	Bearing, Ball	
12	10731825	10	Spring, Cup	
13	10731826	2	Ring, Snap	
14	10731827	2	Shim, End	
15	10731828	2	O-Ring, 60 x 3	
16	10731829	2	O-Ring, 120 x 3	
17	10731830	2	Piston	
18	10731831	1	Carrier, Disc	
19	10731832	1	Ring, Snap	
20	10731833	1	Bearing, Snap	
21	10731834	1	Shim, 0,8mm	
21	10731835	1	Shim, 0,9mm	
21	1319225	1	Shim, 0,95mm	
21	10731836	1	Shim, 1,0mm	
21	10731837	1	Shim, 1,1mm	
21	10731838	1	Shim, 1,2mm	
21	10731839	1	Shim, 1,3mm	
22	10732107	1	Ring, Retaining 77 x 2,5	
23	10731841	1	Cage, Needle	
24	10731842	2	Bush	
25	10731843	1	Gear, Spur Z=27	
26	10731844	1	Ring, Internal	
27	10731845	1	Ring, Retaining 40 x 1,75	
28	10731846	1	Bearing, Ball	
29	10731847	5	Disc, Inner Clutch	
30	10731848	2	Disc, Inner Clutch	
31	10731847	1	Disc, Inner Clutch 2,0mm	
31	10731848	1	Disc, Inner Clutch 1,5mm	
31	10731849	1	Disc, Inner Clutch 2,5mm	
32	10731850	8	Disc, Outer Clutch	
33	10731851	1	Disc, Outer Clutch	
34	10731847	3	Disc, Inner Clutch	
35	10731848	2	Disc, Inner Clutch	
36	10731847	1	Disc, Inner Clutch, 2.0mm	
36	10731848	1	Disc, Inner Clutch, 1.5mm	
36	10731849	1	Disc, Inner Clutch 2,5mm	
37	10731850	6	Disc, Outer Clutch	

SECTION 3 - DRIVE TRAIN

ITEM	PART NUMBER	QTY	DESCRIPTION	REV
38	10731851	1	Disc, Outer Clutch	

SECTION 3 - DRIVE TRAIN

FIGURE 3-16. CLUTCH PACK 2ND GEAR - 1 OF 2 (SN 9909 through 13197)

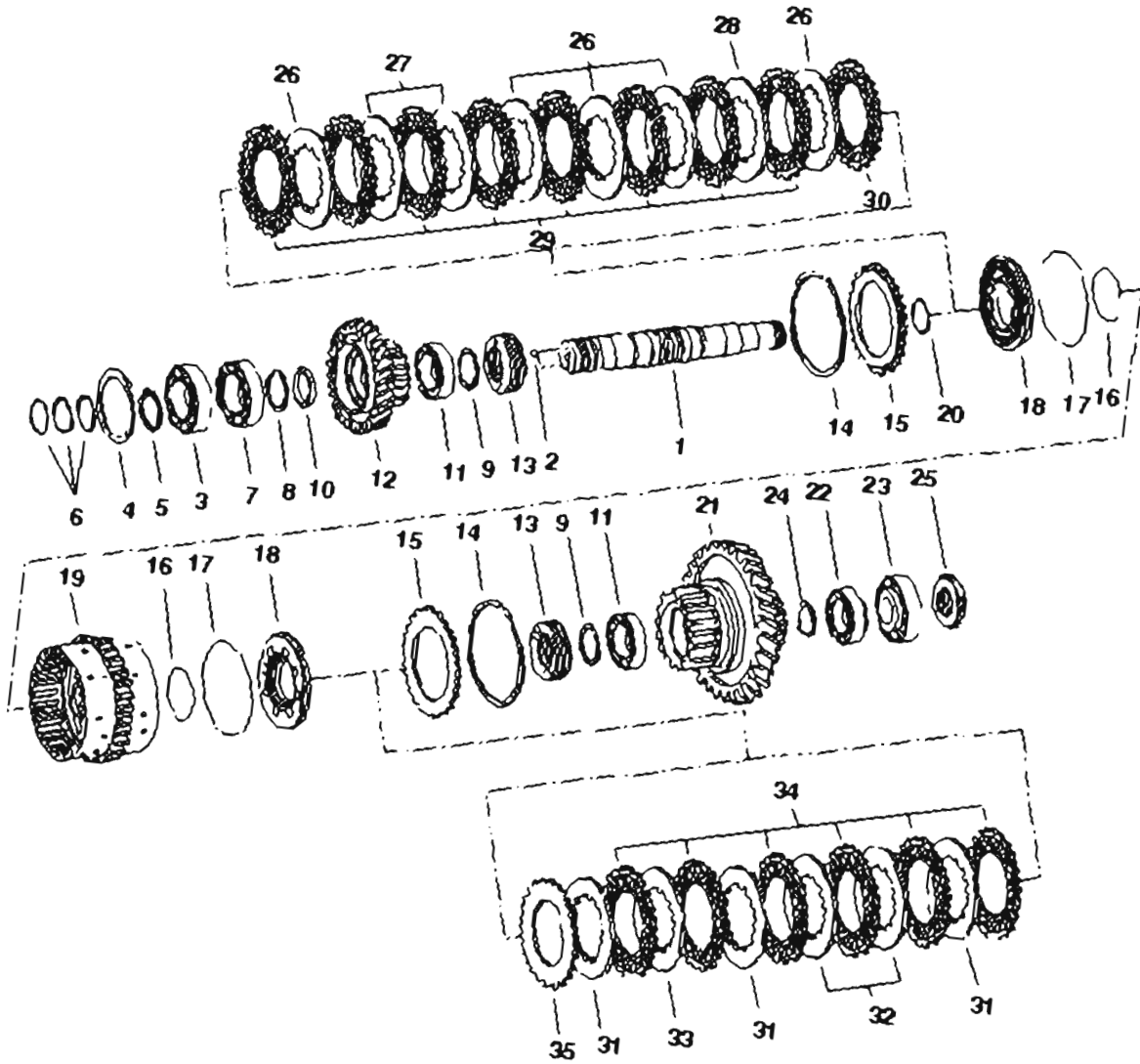

PH1110

SECTION 3 - DRIVE TRAIN

FIGURE 3-16. CLUTCH PACK 2ND GEAR - 1 OF 2 (SN 9909 through 13197)

ITEM	PART NUMBER	QTY	DESCRIPTION	REV
1	1319226	1	Shaft	
2	10731761	2	Ball	
3	1319227	1	Bearing, Roller	
4	10731854	1	Washer, 0,8mm	
4	10731855	1	Washer, 0,85mm	
4	10731856	1	Washer, 0,9mm	
4	10731857	1	Washer, 0,95mm	
4	10731858	1	Washer, 1,0mm	
4	10731859	1	Washer, 1,05mm	
4	10731860	1	Washer, 1,1mm	
4	10731861	1	Washer, 1,15mm	
4	10731862	1	Washer, 1,2mm	
4	10731863	1	Washer, 1,25mm	
4	10731864	1	Washer, 1,3mm	
4	10731865	1	Washer, 1,35mm	
4	10731866	1	Washer, 1,4mm	
4	10731867	1	Washer, 1,45mm	
4	10731868	1	Washer, 1,5mm	
4	10731869	1	Washer, 1,55mm	
4	10731870	1	Washer, 1,6mm	
4	10731871	1	Washer, 1,65mm	
4	10731872	1	Washer, 1,7mm	
4	10731873	1	Washer, 1,75mm	
4	10731874	1	Washer, 1,8mm	
4	10731875	1	Washer, 1,85mm	
4	10731876	1	Washer, 1,9mm	
4	10731877	1	Washer, 1,95mm	
4	10731878	1	Washer, 2,0mm	
4	10731879	1	Washer, 2,05mm	
4	10731880	1	Washer, 2,1mm	
4	10731881	1	Washer, 2,15mm	
4	10731882	1	Washer, 2,2mm	
4	10731883	1	Washer, 2,25mm	
4	10731884	1	Washer, 2,3mm	
4	10731885	1	Washer, 2,35mm	
4	10731886	1	Washer, 2,4mm	
5	10731789	1	Ring, Retaining 45 x 1,75	
6	1319224	3	Ring, Piston 45 x 2,5	
7	1319215	1	Bearing, Roller	
8	10731791	1	Shim, 1,3mm	
8	10731792	1	Shim, 1,35mm	
8	10731793	1	Shim, 1,4mm	
8	10731794	1	Shim, 1,45mm	
8	10731795	1	Shim, 1,5mm	
8	10731796	1	Shim, 1,55mm	
8	10731797	1	Shim, 1,6mm	
8	10731798	1	Shim, 1,65mm	
8	10731799	1	Shim, 1,7mm	
8	10731800	1	Shim, 1,75mm	
8	10731801	1	Shim, 1,8mm	

SECTION 3 - DRIVE TRAIN

ITEM	PART NUMBER	QTY	DESCRIPTION	REV
8	10731802	1	Shim, 1,85mm	
8	10731803	1	Shim, 1,9mm	
8	10731804	1	Shim, 1,95mm	
8	10731805	1	Shim, 2,0mm	
8	10731806	1	Shim, 2,05mm	
8	10731807	1	Shim, 2,1mm	
8	10731808	1	Shim, 2,15mm	
8	10731809	1	Shim, 2,2mm	
8	10731810	1	Shim, 2,25mm	
8	10731811	1	Shim, 2,3mm	
8	10731812	1	Shim, 2,35mm	
8	10731813	1	Shim, 2,4mm	
8	10731814	1	Shim, 2,45mm	
8	10731815	1	Shim, 2,5mm	
8	10731816	1	Shim, 2,55mm	
8	10731817	1	Shim, 2,6mm	
8	10731818	1	Shim, 2,65mm	
8	10731819	1	Shim, 2,7mm	
8	10731820	1	Shim, 2,75mm	
8	10731821	1	Shim, 2,8mm	
9	10731805	2	Shim	
10	10731887	1	Bush	
11	10731888	2	Bearing, Roller	

SECTION 3 - DRIVE TRAIN

FIGURE 3-17. CLUTCH PACK 2ND GEAR - 2 OF 2 (SN 9909 through 13197)

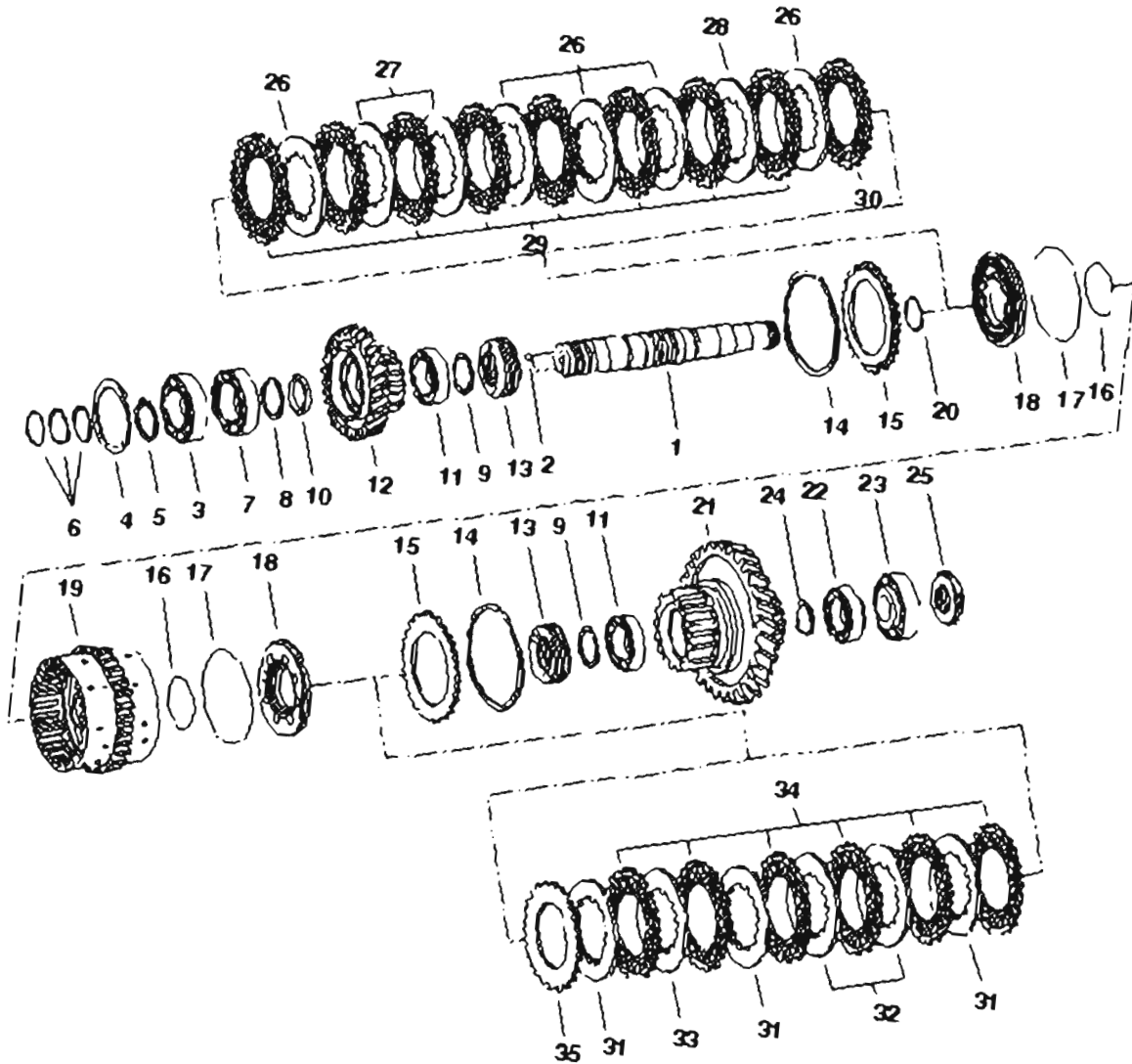

PH1110

SECTION 3 - DRIVE TRAIN

FIGURE 3-17. CLUTCH PACK 2ND GEAR - 2 OF 2 (SN 9909 through 13197)

ITEM	PART NUMBER	QTY	DESCRIPTION	REV
12	10731889	1	Gear, Spur Z=44	
13	10731825	10	Spring, Cup	
14	10731826	2	Ring, Snap	
15	10731827	2	Shim, End	
16	10731828	2	O-Ring, 60 x 3	
17	10731829	2	O-Ring, 120 x 3	
18	10731830	2	Piston	
19	10731831	1	Carrier, Disc	
20	10731832	1	Ring, Snap 48	
21	10731890	1	Gear, Spur	
22	10731891	1	Bearing, Roller	
23	10731892	1	Bearing, Roller	
24	10731893	1	Shim, 1,0mm	
24	10731894	1	Shim, 1,05mm	
24	10731895	1	Shim, 1,1mm	
24	10731896	1	Shim, 1,15mm	
24	10731897	1	Shim, 1,2mm	
24	10731898	1	Shim, 1,25mm	
24	10731899	1	Shim, 1,3mm	
24	10731900	1	Shim, 1,35mm	
24	10731901	1	Shim, 1,4mm	
24	10731902	1	Shim, 1,45mm	
24	10731903	1	Shim, 1,5mm	
24	10731904	1	Shim, 1,55mm	
24	10731905	1	Shim, 1,6mm	
24	10731906	1	Shim, 1,65mm	
24	10731907	1	Shim, 1,7mm	
24	10731908	1	Shim, 1,75mm	
24	10731909	1	Shim, 1,8mm	
25	10731910	1	Nut, Slotted	
26	10731847	5	Disc, Inner Clutch	
27	10731848	2	Disc, Inner Clutch	
28	10731847	1	Disc, Inner Clutch 2,0mm	
28	10731848	1	Disc, Inner Clutch 1,5mm	
28	10731849	1	Disc, Inner Clutch 2,5mm	
29	10731850	8	Disc, Outer Clutch	
30	10731851	1	Disc, Outer Clutch	
31	10731847	3	Disc, Inner Clutch	
32	10731848	2	Disc, Inner Clutch	
33	10731847	1	Disc, Inner Clutch 2,0mm	
33	10731848	1	Disc, Inner Clutch 1,5mm	
33	10731849	1	Disc, Inner Clutch 2,5mm	
34	10731850	6	Disc, Outer Clutch	
35	10731851	1	Disc, Outer Clutch	

SECTION 3 - DRIVE TRAIN

FIGURE 3-18. CLUTCH PACK 3RD GEAR - 1 OF 2 (SN 9909 through 13197)

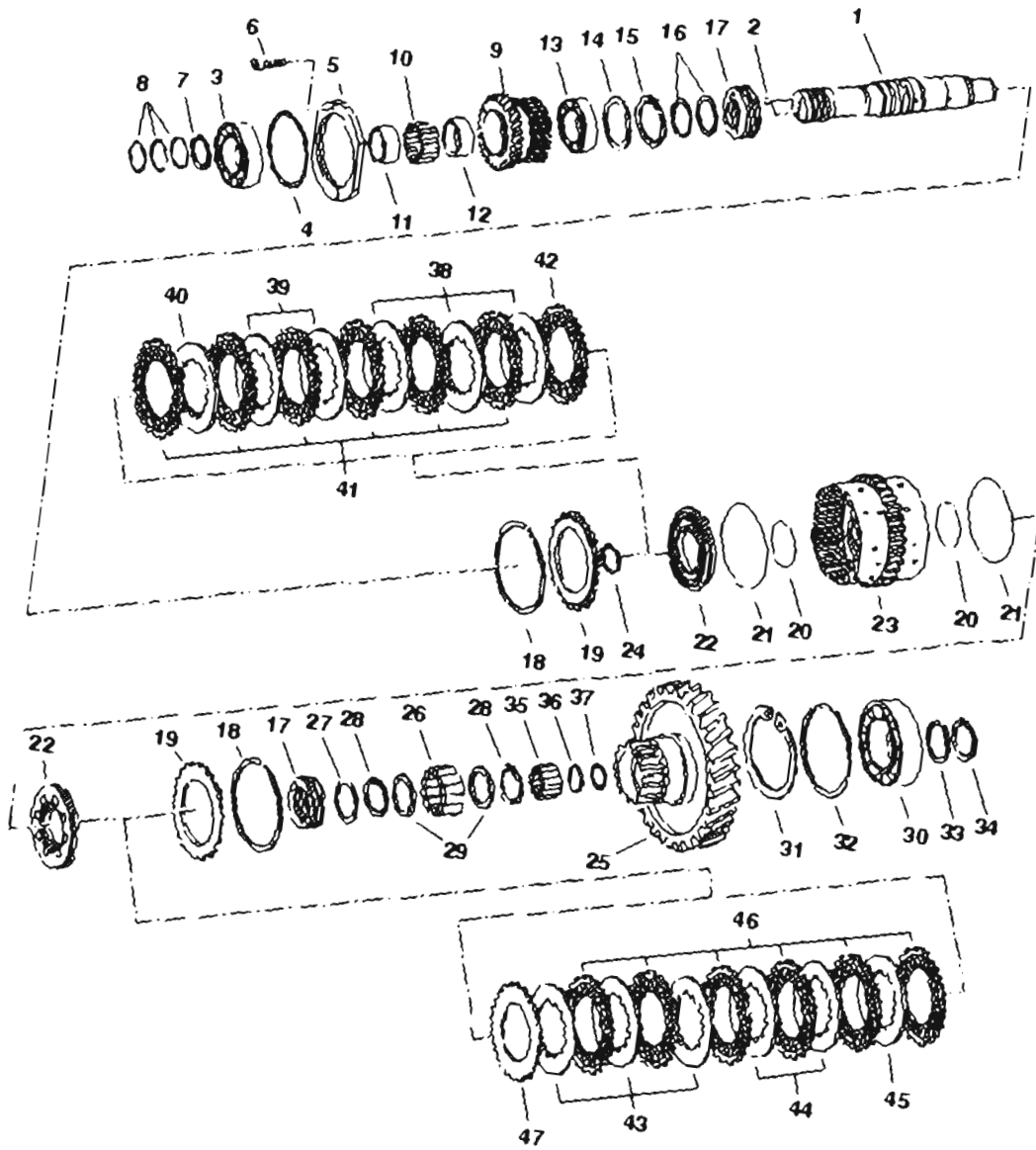

PH1120

SECTION 3 - DRIVE TRAIN

FIGURE 3-18. CLUTCH PACK 3RD GEAR - 1 OF 2 (SN 9909 through 13197)

ITEM	PART NUMBER	QTY	DESCRIPTION	REV
1	10731911	1	Shaft	
2	10731761	2	Ball	
3	10731912	1	Bearing, Ball	
4	10731913	1	Ring, Snap 100	
5	1319230	1	Washer	
6	1319220	2	HHCS, M8 x 35mm	
7	10731789	1	Ring, Retaining 45 x 1,75	
8	1319224	3	Ring, Piston 45 x 2,5	
9	10732103	1	Gear, Spur Z=29	
10	10732104	1	Cage, Needle	
11	10732105	1	Ring, Internal	
12	10732106	1	Bush	
13	10731824	1	Bearing, Ball	
14	10731834	1	Shim, 0,8mm	
14	10731835	1	Shim, 0,9mm	
14	1319225	1	Shim, 0,95mm	
14	10731836	1	Shim, 1,0mm	
14	10731837	1	Shim, 1,1mm	
14	10731838	1	Shim, 1,2mm	
14	10731839	1	Shim, 1,3mm	
15	10732107	1	Ring, Retaining 77 x 2,5	
16	10731791	2	Shim, 1,3mm	
16	10731792	2	Shim, 1,35mm	
16	10731793	2	Shim, 1,4mm	
16	10731794	2	Shim, 1,45mm	
16	10731795	2	Shim, 1,5mm	
16	10731796	2	Shim, 1,55mm	
16	10731797	2	Shim, 1,6mm	
16	10731798	2	Shim, 1,65mm	
16	10731799	2	Shim, 1,7mm	
16	10731800	2	Shim, 1,75mm	
16	10731801	2	Shim, 1,8mm	
16	10731802	2	Shim, 1,85mm	
16	10731803	2	Shim, 1,9mm	
16	10731804	2	Shim, 1,95mm	
16	10731805	2	Shim, 2,0mm	
16	10731806	2	Shim, 2,05mm	
16	10731807	2	Shim, 2,1mm	
16	10731808	2	Shim, 2,15mm	
16	10731809	2	Shim, 2,2mm	
16	10731810	2	Shim, 2,25mm	
16	10731811	2	Shim, 2,3mm	
16	10731812	2	Shim, 2,35mm	
16	10731813	2	Shim, 2,4mm	
16	10731814	2	Shim, 2,45mm	
16	10731815	2	Shim, 2,5mm	
16	10731816	2	Shim, 2,55mm	
16	10731817	2	Shim, 2,6mm	
16	10731818	2	Shim, 2,65mm	
16	10731819	2	Shim, 2,7mm	

SECTION 3 - DRIVE TRAIN

ITEM	PART NUMBER	QTY	DESCRIPTION	REV
16	10731820	2	Shim, 2,75mm	
16	10731821	2	Shim, 2,8mm	
17	10731825	10	Spring, Cup	
18	10731826	2	Ring, Snap	
19	10731827	2	Shim, End	

SECTION 3 - DRIVE TRAIN

FIGURE 3-19. CLUTCH PACK 3RD GEAR - 2 OF 2 (SN 9909 through 13197)

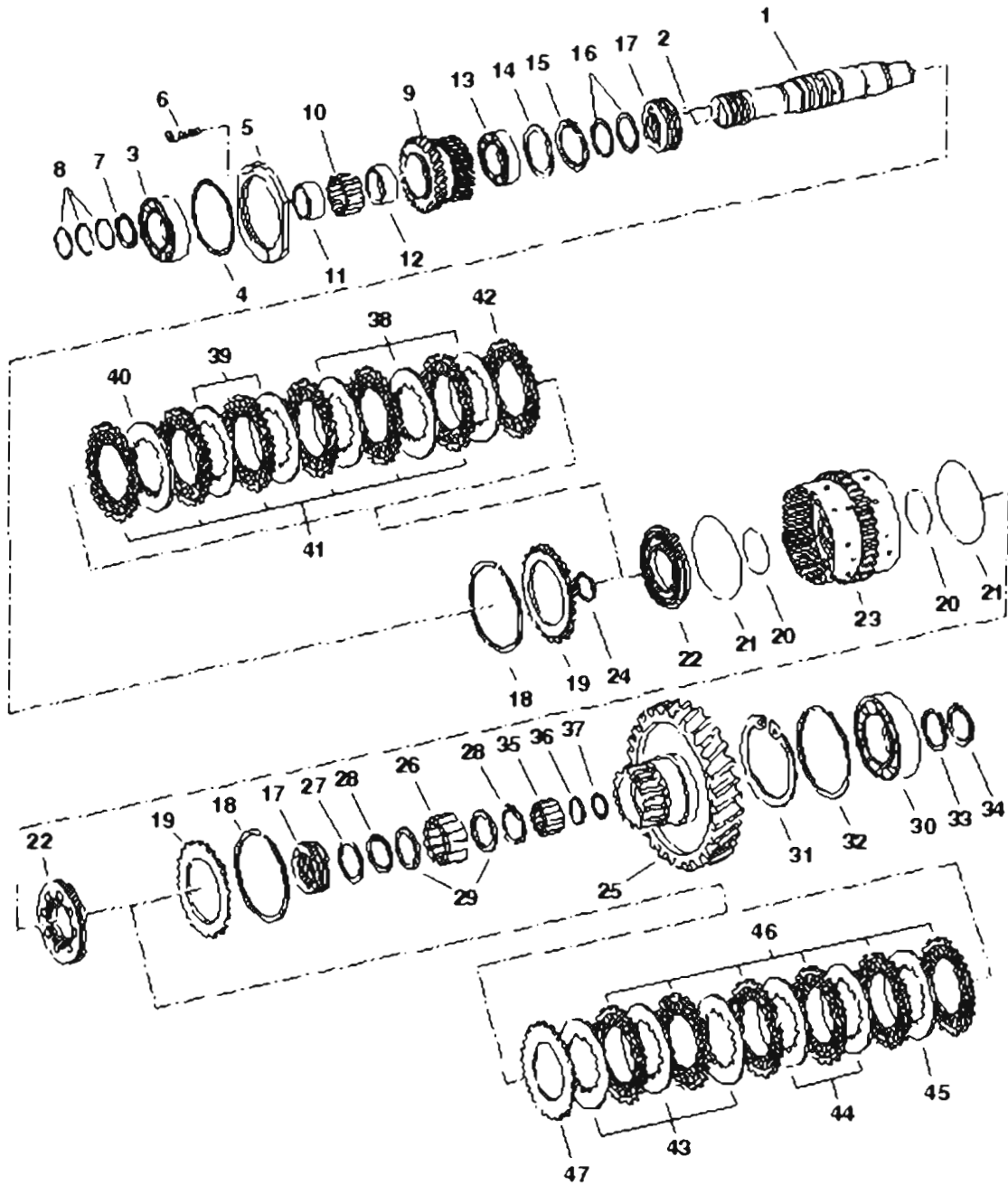

PH1120

SECTION 3 - DRIVE TRAIN

FIGURE 3-19. CLUTCH PACK 3RD GEAR - 2 OF 2 (SN 9909 through 13197)

ITEM	PART NUMBER	QTY	DESCRIPTION	REV
20	10731828	2	O-Ring, 60 x 3	
21	10731829	2	O-Ring, 120 x 3	
22	10731830	2	Piston	
23	10731916	1	Carrier, Disc	
24	10731832	1	Ring, Snap 48	
25	10731917	1	Gear, Spur Z=56	
26	10731918	1	Cage, Roller	
27	10731919	1	Shim, 3,4mm	
27	10731920	1	Shim, 1,6mm	
28	10731921	2	Ring, Retaining 48 x 1,75	
29	1319234	2	Washer, Thrust	
30	1319235	1	Bearing, Roller	
31	10731928	1	Ring, Retaining 120 x 4	
32	10731929	1	Washer, 1,0mm	
32	10731930	1	Washer, 1,05mm	
32	10731931	1	Washer, 1,1mm	
32	10731932	1	Washer, 1,15mm	
32	10731933	1	Washer, 1,2mm	
32	10731934	1	Washer, 1,25mm	
32	10731935	1	Washer, 1,3mm	
32	10731936	1	Washer, 1,35mm	
32	10731937	1	Washer, 1,4mm	
33	10731938	1	Shim, 0,8mm	
33	10731839	1	Shim, 0,85mm	
33	10731840	1	Shim, 0,9mm	
33	10731841	1	Shim, 0,95mm	
33	10731842	1	Shim, 1,0mm	
33	10731843	1	Shim, 1,05mm	
33	10731844	1	Shim, 1,1mm	
33	10731845	1	Shim, 1,15mm	
33	10731846	1	Shim, 1,2mm	
33	10731847	1	Shim, 1,25mm	
33	10731848	1	Shim, 1,3mm	
34	10731849	1	Ring, Retaining 65 x 2,5	
35	10731850	1	Cage, Needle	
36	10731851	1	Shim	
37	10731852	1	Ring, Retaining 30 x 1,5	
38	10731847	3	Disc, Inner Clutch	
39	10731848	2	Disc, Inner Clutch	
40	10731847	1	Disc, Inner Clutch 2,0mm	
40	10731848	1	Disc, Inner Clutch 1,5mm	
40	10731849	1	Disc, Inner Clutch 2,5mm	
41	10731850	6	Disc, Outer Clutch	
42	10731851	1	Disc, Outer Clutch	
43	10731847	3	Disc, Inner Clutch	
44	10731848	2	Disc, Inner Clutch	
45	10731847	1	Disc, Inner Clutch 2,0mm	
45	10731848	1	Disc, Inner Clutch 1,5mm	
45	10731849	1	Disc, Inner Clutch 2,5mm	
46	10731850	6	Disc, Outer Clutch	

SECTION 3 - DRIVE TRAIN

ITEM	PART NUMBER	QTY	DESCRIPTION	REV
47	10731851	1	Disc, Outer Clutch	

SECTION 3 - DRIVE TRAIN

FIGURE 3-20. OUTPUT SHAFT (SN 9909 through 13197)

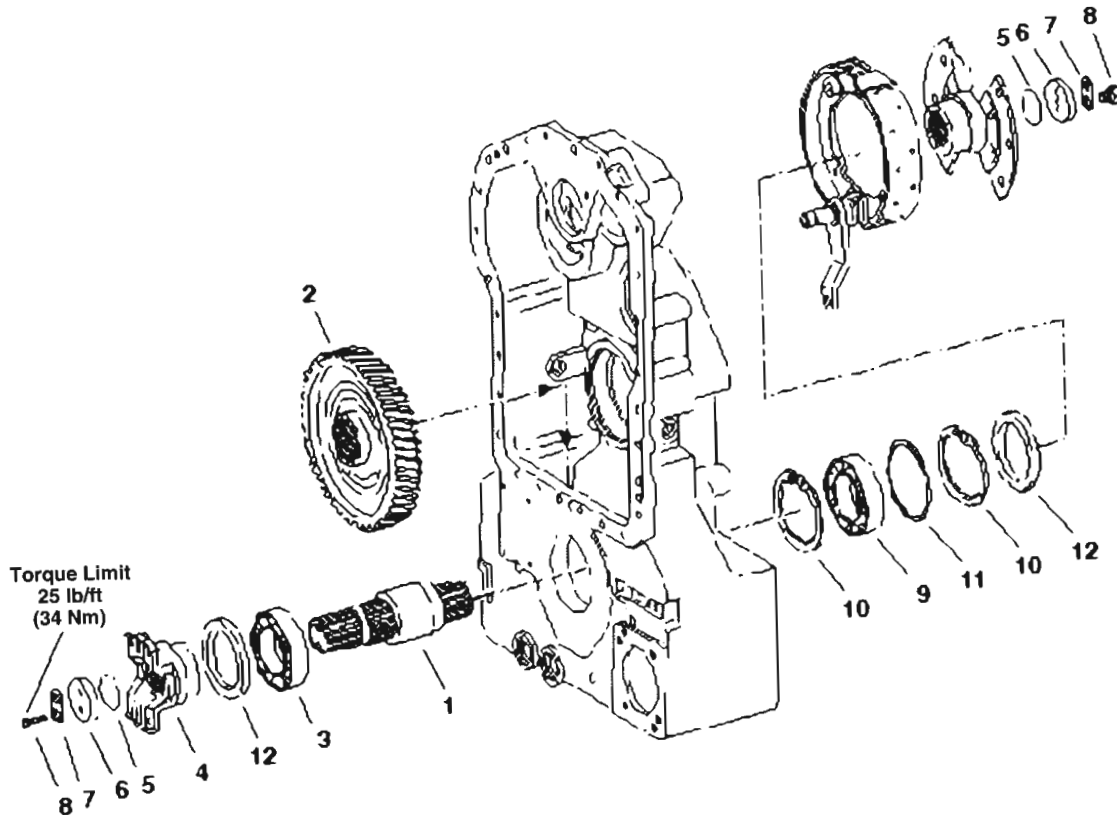

PH1130

SECTION 3 - DRIVE TRAIN

FIGURE 3-20. OUTPUT SHAFT (SN 9909 through 13197)

ITEM	PART NUMBER	QTY	DESCRIPTION	REV
1	10731953	1	Shaft, Output	
2	10731954	1	Gear, Output	
3	10731955	1	Bearing, Ball	
4	10731956	1	Flange, Input	
5	10839156	2	O-Ring, 38 x 4	
6	10731957	2	Washer	
7	10731958	2	Washer, Tab	
8	10731959	4	HHCS, M8 x 25mm	
9	10731960	1	Bearing, Ball	
10	10731961	2	Ring, Retaining 100 x 3	
11	10731962	1	Shim, 1,0mm	
11	10731963	1	Shim, 1,05mm	
11	10731964	1	Shim, 1,1mm	
11	10731965	1	Shim, 1,15mm	
11	10731966	1	Shim, 1,2mm	
11	10731967	1	Shim, 1,25mm	
11	10731968	1	Shim, 1,3mm	
11	10731969	1	Shim, 1,35mm	
11	10731970	1	Shim, 1,4mm	
11	10731971	1	Shim, 1,45mm	
11	10731972	1	Shim, 1,5mm	
11	10731973	1	Shim, 1,55mm	
11	10731974	1	Shim, 1,6mm	
11	10731975	1	Shim, 1,65mm	
11	10731976	1	Shim, 1,7mm	
12	10731977	2	Seal, Shaft 70 x 100 x 10	

SECTION 3 - DRIVE TRAIN

FIGURE 3-21. PARKING BRAKE (SN 9909 through 13197)

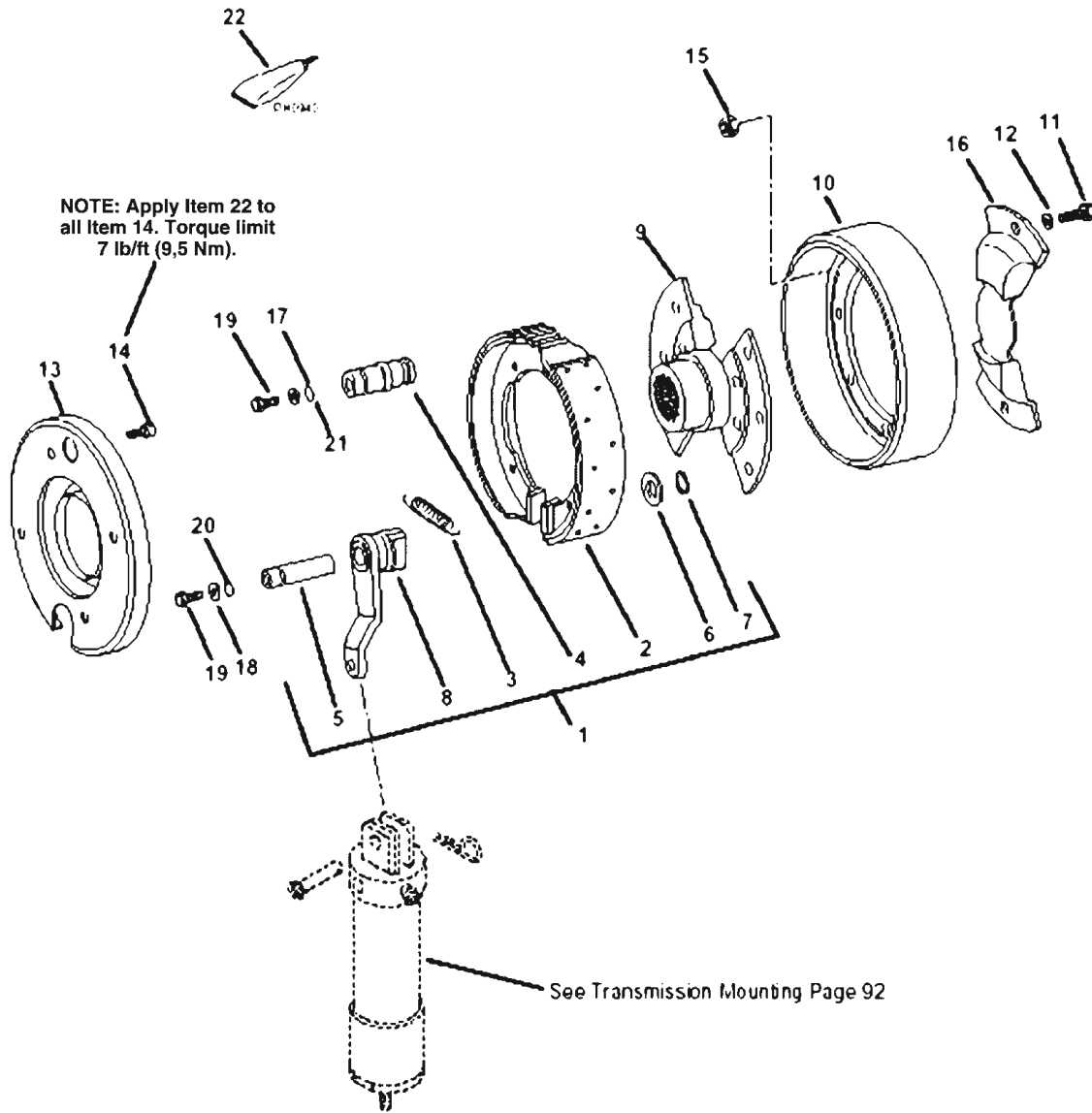

SECTION 3 - DRIVE TRAIN

FIGURE 3-21. PARKING BRAKE (SN 9909 through 13197)

ITEM	PART NUMBER	QTY	DESCRIPTION	REV
1	10731981	1	Shoe, Brake (Includes Items 2 thru 8)	
2	10731982	2	Shoe, Brake Without Asbestos	
3	10731983	2	Spring, Tension	
4	10731984	1	Bolt, Anchor	
5	10731985	1	Pin	
6	10731986	1	Washer	
7	10731987	1	Ring, Retaining 22 x 1,2	
8	10731988	1	Cam, Brake	
9	10732097	1	Flange, Output	
10	10732093	1	Drum, Brake	
11	10732094	8	HHCS, M10 x 25mm	
12	10732095	8	Washer, 10,5	
13	1319237	1	Plate, Cover	
14	10731980	4	SHCS, M6 x 10mm	
15	10731751	2	Nut, Hex M10	
16	10732098	1	Plate, Cover	
17	10732099	1	Washer	
18	10732099	1	Washer	
19	10732101	2	HHCS, M10 x 22mm	
20	10731978	1	O-Ring, 17,3 x 2,4	
21	10731979	1	O-Ring, 25,3 x 2,4	
22	8526052	AR	Threadlocker, High Strength	

SECTION 3 - DRIVE TRAIN

FIGURE 3-22. POWER TAKE-OFF SHAFT (SN 9909 through 13197)

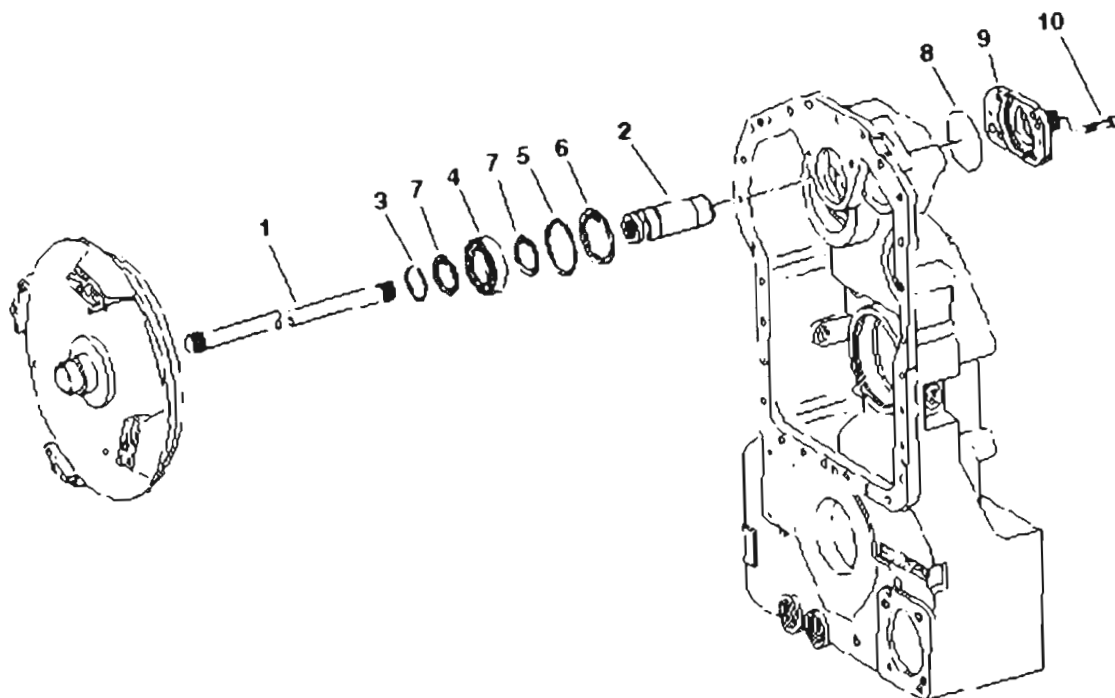

PH1150

SECTION 3 - DRIVE TRAIN

FIGURE 3-22. POWER TAKE-OFF SHAFT (SN 9909 through 13197)

ITEM	PART NUMBER	QTY	DESCRIPTION	REV
1	10731989	1	Shaft, Central	
2	1319238	1	Bush	
3	1319218	1	Ring, Piston	
4	1319240	1	Bearing, Ball	
5	10731992	1	Shim, 1,0mm	
5	10731993	1	Shim, 1,05mm	
5	10731994	1	Shim, 1,1mm	
5	10731995	1	Shim, 1,15mm	
5	10731996	1	Shim, 1,2mm	
5	10731997	1	Shim, 1,25mm	
5	10731998	1	Shim, 1,3mm	
5	10731999	1	Shim, 1,35mm	
5	10732000	1	Shim, 1,40mm	
5	10732001	1	Shim, 1,45mm	
5	10732002	1	Shim, 1,5mm	
5	10732003	1	Shim, 1,55mm	
5	10732004	1	Shim, 1,6mm	
5	1319241	1	Shim, 1,65mm	
5	1319242	1	Shim, 1,70mm	
5	1319243	1	Shim, 1,75mm	
5	1319244	1	Shim, 1,80mm	
5	1319245	1	Shim, 1,85mm	
5	1319246	1	Shim, 1,90mm	
5	1319247	1	Shim, 1,95mm	
5	1319248	1	Shim, 2,00mm	
5	1319249	Ref	Shim, 2,05mm (No Longer Available; Use 1 Each Of 10731992 & 10731993)	
5	1319250	1	Shim, 2,10mm	
5	1319251	1	Shim, 2,15mm	
5	1319252	1	Shim, 2,20mm	
6	10732005	1	Ring, Retaining 68 x 2,5	
7	10731845	2	Ring, Retaining 40 x 1,75	
8	1319253	1	O-Ring, 104 x 3	
9	1319254	1	Flange, Pump	
10	1319255	2	SHCS, M14 x 35mm	

SECTION 3 - DRIVE TRAIN

FIGURE 3-23. GEARSHIFT SYSTEM (SN 9909 through 13197)

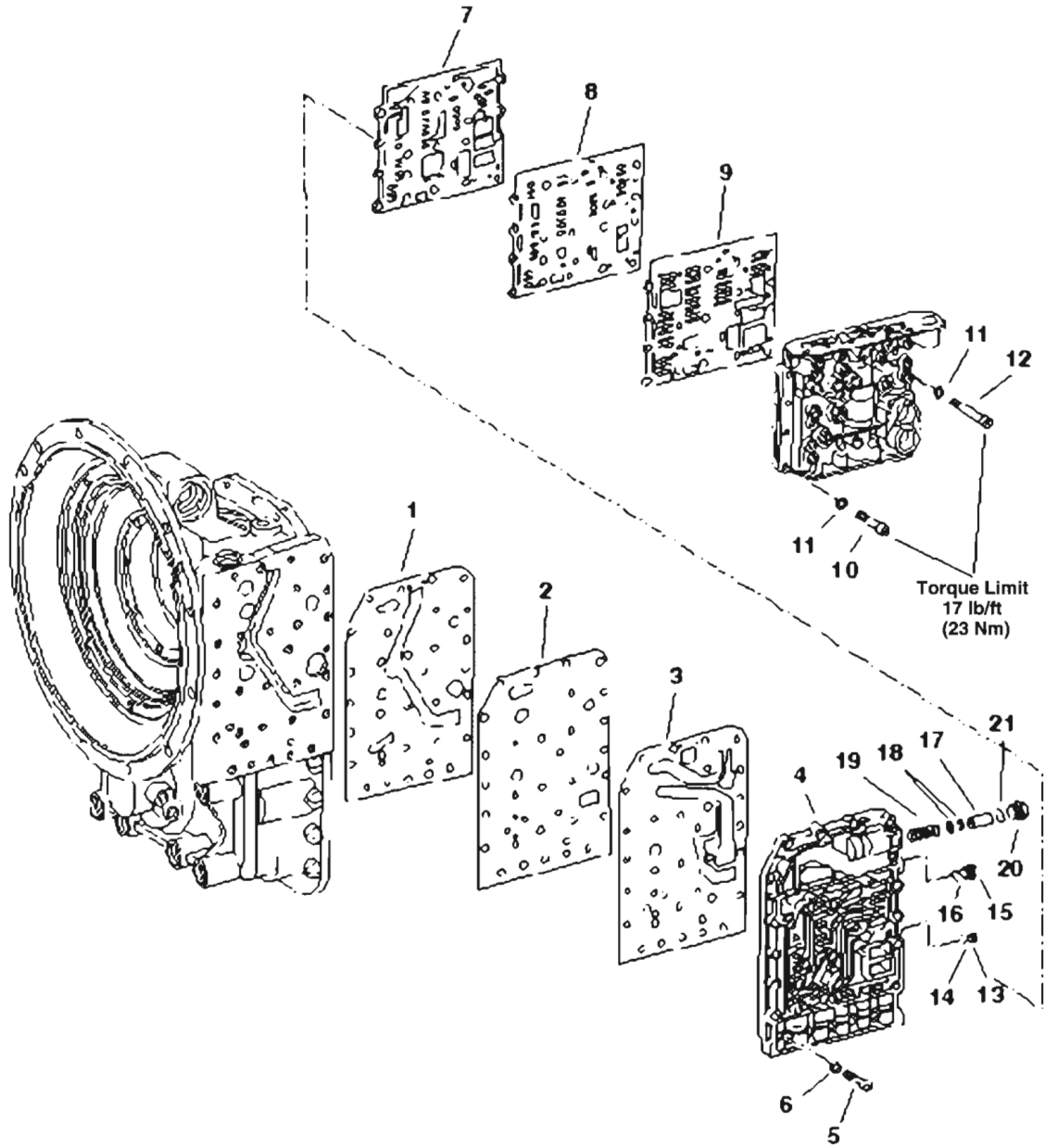

PH1160

SECTION 3 - DRIVE TRAIN

FIGURE 3-23. GEARSHIFT SYSTEM (SN 9909 through 13197)

ITEM	PART NUMBER	QTY	DESCRIPTION	REV
1	1319256	1	Gasket	
2	10732007	1	Plate, Cover	
3	1319257	1	Gasket	
4	10732009	1	Plate, Duct	
5	1319220	11	SHCS, M8 x 35mm	
6	10731710	11	Washer, 8,4	
7	10732011	1	Gasket	
8	10732012	1	Plate, Cover	
9	10732013	1	Gasket	
10	1319259	16	SHCS, M8 x 65mm	
11	10731710	17	Washer, 8,4	
12	1319260	1	SHCS, M8 x 85mm	
13	10732017	1	Plug, M10 x 1	
14	10731709	1	O-Ring, 8 x 1,5	
15	1319261	1	Plug, M14 x 1,5	
16	10837660	1	O-Ring, 11 x 2	
17	10732021	1	Spool, Valve	
18	10732022	2	Washer, 6,4	
19	10732023	1	Spring, Compression	
20	10732024	1	Plug, M20 x 1,5	
21	10732025	1	O-Ring, 17 x 2	

SECTION 3 - DRIVE TRAIN

FIGURE 3-24. CONTROL VALVE (SN 9909 through 13197)

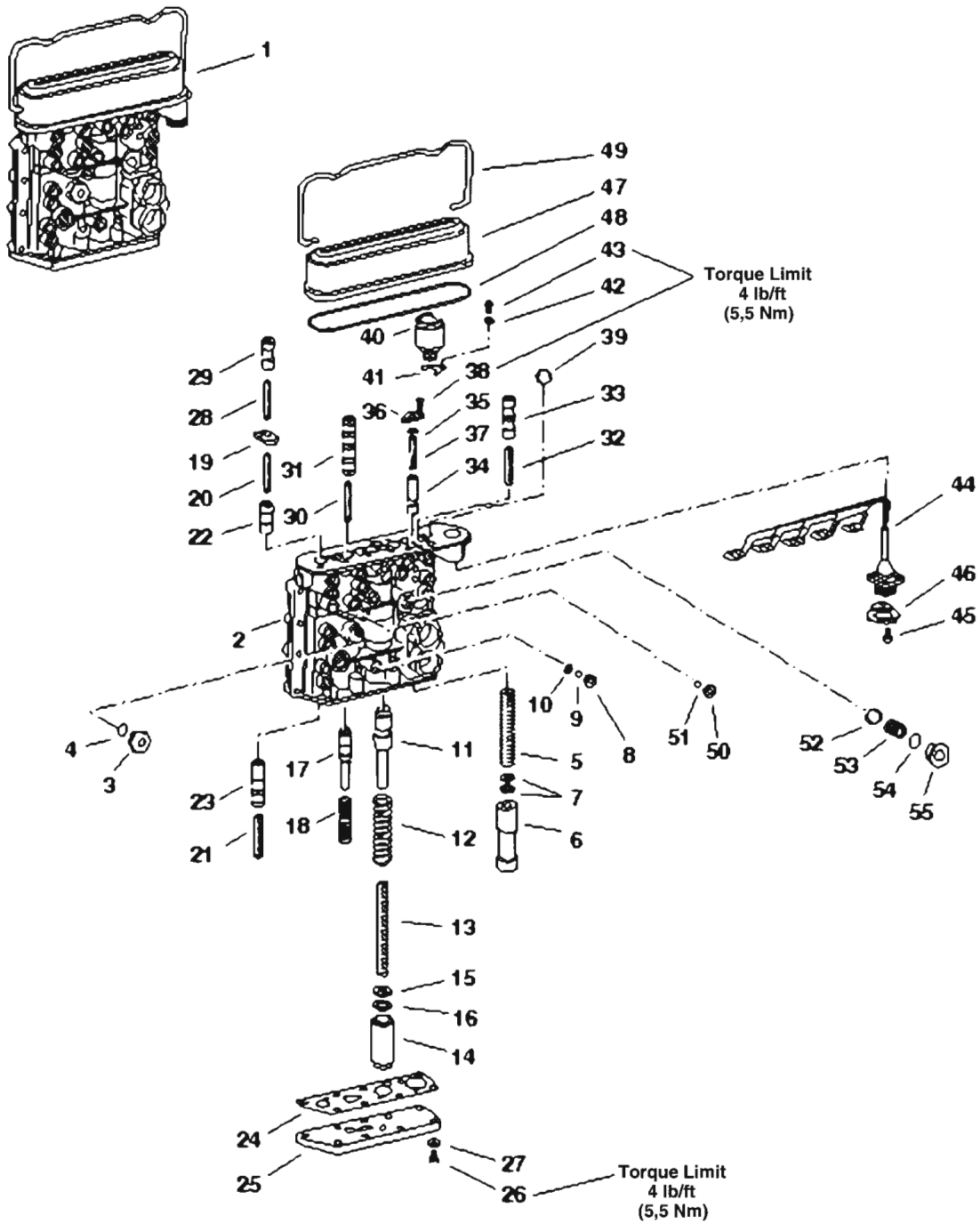

PH1170

SECTION 3 - DRIVE TRAIN

FIGURE 3-24. CONTROL VALVE (SN 9909 through 13197)

ITEM	PART NUMBER	QTY	DESCRIPTION	REV
1	10837728	1	Valve Assembly, Control (Includes Items 2 thru 55)	
2	1319262	1	Housing, Valve	
3	1319263	1	Sleeve, Screw-In	
4	10732018	1	O-Ring, 15 x 2	
5	10732027	1	Spring, Compression	
6	10732028	1	Piston	
7	10732029	2	Ring, Shim 10 x 16 x 1	
8	10732030	1	Orifice, 0,6mm	
8	10732031	1	Orifice, 0,7mm	
8	10732032	1	Orifice, 0,8mm	
8	10732033	1	Orifice, 0,65mm	
8	10732034	1	Orifice, 0,75mm	
8	10732035	1	Orifice, 0,85mm	
8	10732036	1	Orifice, 0,90mm	
8	1319264	1	Orifice, 0,95mm	
9	10731709	1	O-Ring, 8 x 1,5	
10	10732037	1	O-Ring, 6 x 1,5	
11	10732038	1	Piston	
12	10732039	1	Spring, Compression	
13	10732040	1	Spring, Compression	
14	10732041	1	Piston	
15	10732042	1	Washer	
16	10732043	1	Ring, Shim 15 x 21 x 2	
16	10732044	1	Ring, Shim 15 x 21 x 1	
16	10732045	1	Ring, Shim 15 x 21 x 0,5	
17	10732046	1	Piston	
18	10732047	1	Spring, Compression	
19	10732048	1	Plate, Stop	
20	10732049	1	Spring, Compression	
21	10732049	1	Spring, Compression	
22	10732050	1	Piston	
23	10732051	1	Piston	
24	1319265	1	Gasket	
25	10732053	1	Cover	
26	10732054	9	SHCS, M6 x 20mm	
27	10732015	9	Washer, M6	
28	10732049	1	Spring, Compression	
29	10732050	1	Piston	
30	10732049	1	Spring, Compression	
31	10732055	1	Piston	
32	10732049	1	Spring, Compression	
33	10732056	1	Piston	
34	1319266	1	Valve, Reduction	
35	1319267	1	Ring	
36	1319268	1	Plate, Fixing	
37	10732058	1	Spring, Compression	
38	10732060	2	SHCS, M5 x 12mm	
39	10732061	10	Ball	
40	1319269	5	Valve, Solenoid	
41	10732063	5	Plate, Fixing	

SECTION 3 - DRIVE TRAIN

ITEM	PART NUMBER	QTY	DESCRIPTION	REV
42	10732064	5	Washer	
43	10732060	5	SHCS, M5 x 12mm	
44	10732065	1	Harness, Wiring	
45	1319270	2	SHCS, M6 x 14mm	
46	10732067	1	Plate, Fixing	
47	10732068	1	Cover	
48	10732069	1	O-Ring, 159,2 x 5,7	
49	10732070	1	Bracket, Clamp	
50	10732017	8	Plug, M10 x 1	
51	10731709	8	O-Ring, 8 x 1,5	
52	10732071	2	Ball	
53	10732072	2	Spring, Compression	
54	10732018	2	O-Ring, 15 x 2	
55	10732076	2	Plug, M18 x 1,5	

SECTION 3 - DRIVE TRAIN

FIGURE 3-25. TRANSMISSION FILTER AND DIPSTICK (SN 9909 through 13197)

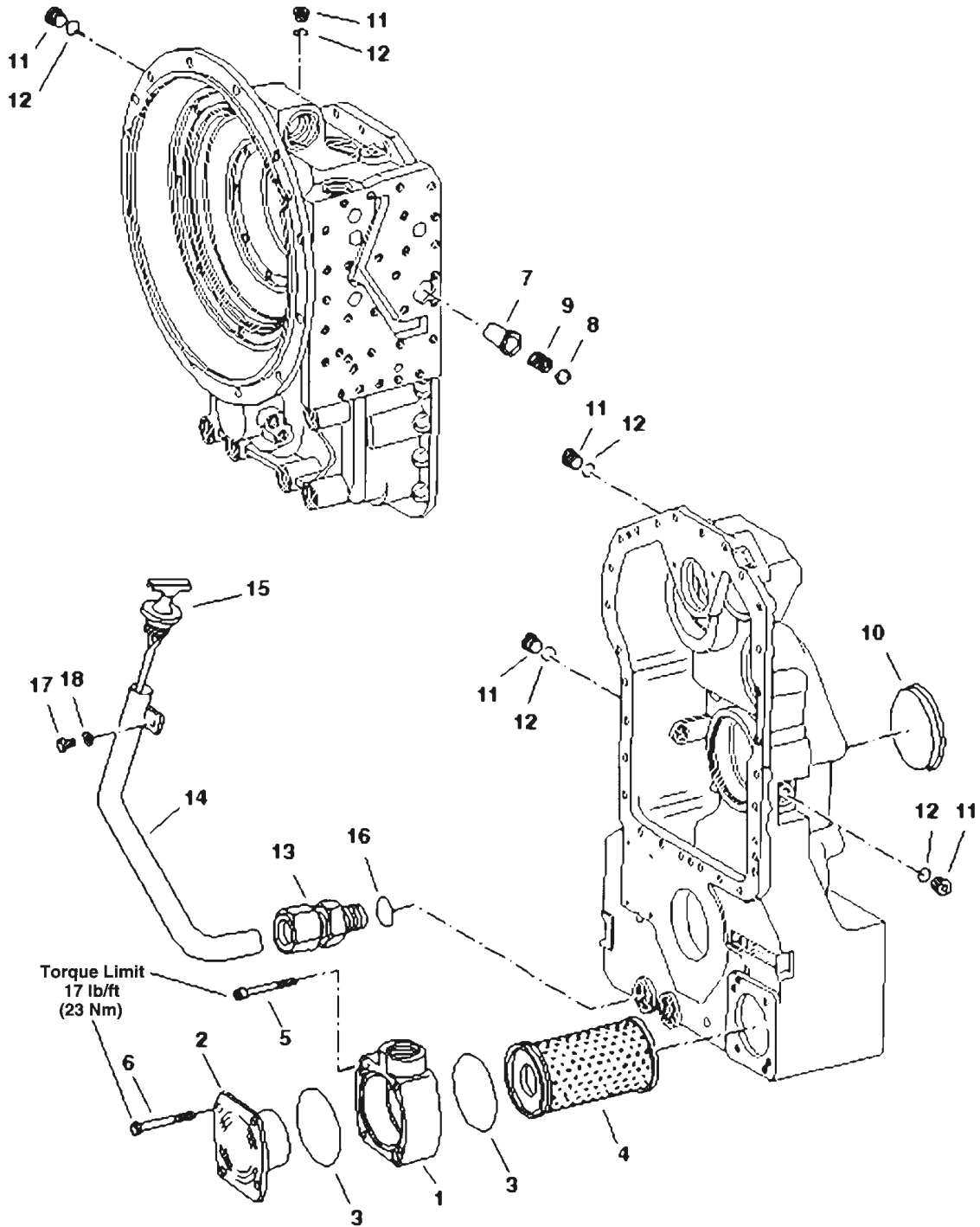

PH1180

SECTION 3 - DRIVE TRAIN

FIGURE 3-25. TRANSMISSION FILTER AND DIPSTICK (SN 9909 through 13197)

ITEM	PART NUMBER	QTY	DESCRIPTION	REV
1	10731923	1	Fixture, Holding	
2	10731924	1	Cover	
3	10731925	2	O-Ring, 98 x 4	
4	10731926	1	Filter	
5	1319271	2	SHCS, M8 x 60mm	
6	1319272	4	HHCS, M8 x 75mm	
7	1319273	1	Insert, Valve	
8	10732071	1	Ball	
9	1319274	1	Spring, Compression	
10	10732083	1	Cap, Sealing	
11	10732076	5	Plug, M18 x 1,5	
12	10732018	5	O-Ring, 15 x 2	
13	10732078	1	Union, Pipe	
14	8035733	1	Tube, Oil Level	
15	8035734	1	Dipstick, Oil	
16	10731743	1	O-Ring, 30 x 2,5	
17	10732081	1	HHCS, M20 x 20mm	
18	10732082	1	Washer, M20	

SECTION 3 - DRIVE TRAIN

FIGURE 3-26. OIL TUBES (SN 9909 through 13197)

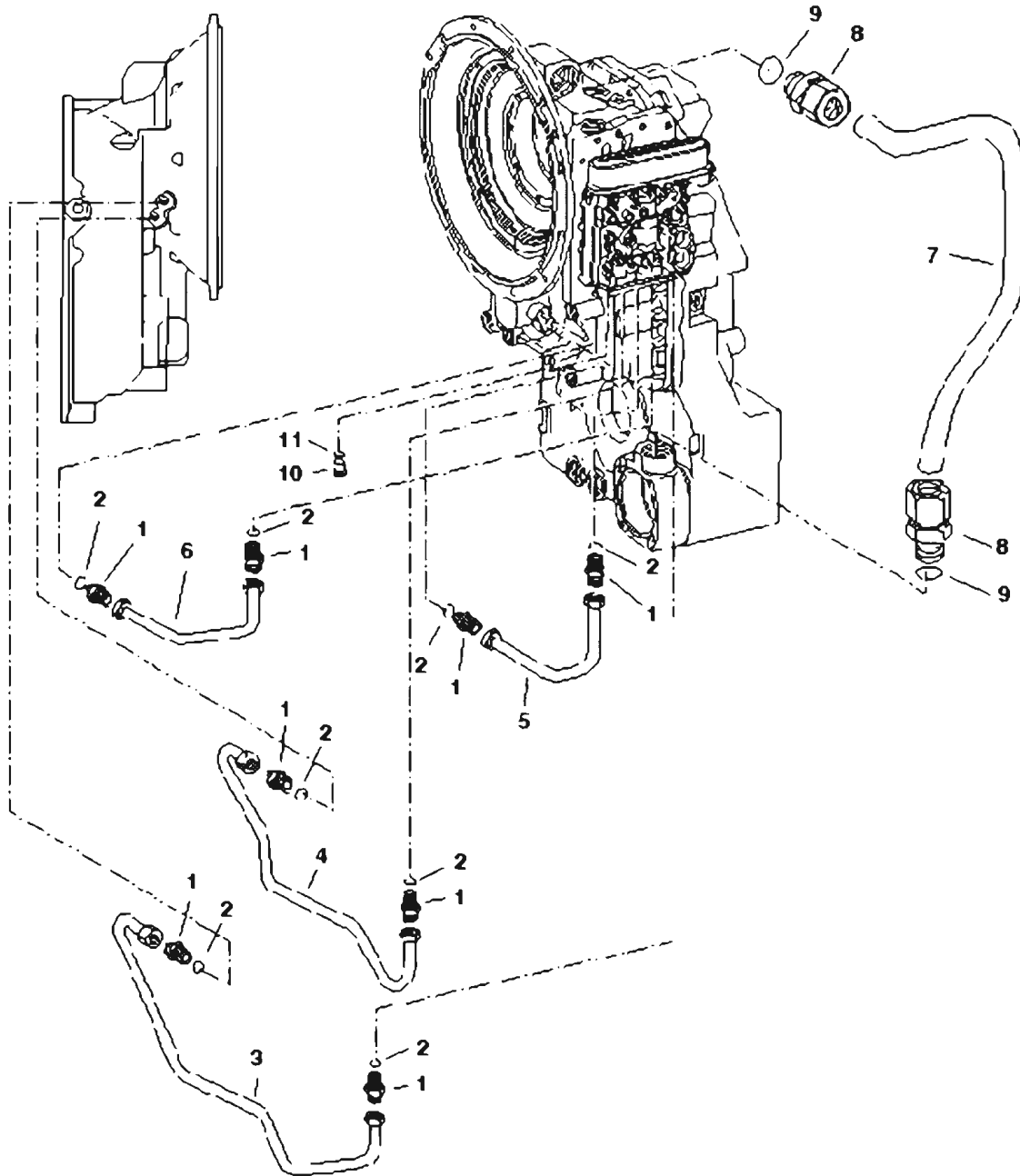

PH1210

SECTION 3 - DRIVE TRAIN

FIGURE 3-26. OIL TUBES (SN 9909 through 13197)

ITEM	PART NUMBER	QTY	DESCRIPTION	REV
1	1319275	8	Sleeve, Screw-In	
2	10732085	8	O-Ring, 13 x 2	
3	1319276	1	Pipe	
4	1319277	1	Pipe	
5	1319278	1	Pipe	
6	1319279	1	Pipe	
7	10732089	1	Tube, Suction	
8	10732090	2	Union, Pipe	
9	10732091	2	O-Ring, 38 x 2,5	
10	10732092	2	Plug, M16 x 1,5	
11	10732085	2	O-Ring, 13 x 2	

SECTION 3 - DRIVE TRAIN

FIGURE 3-27. TRANSMISSION MOUNTING (SN 9909 through 13197)

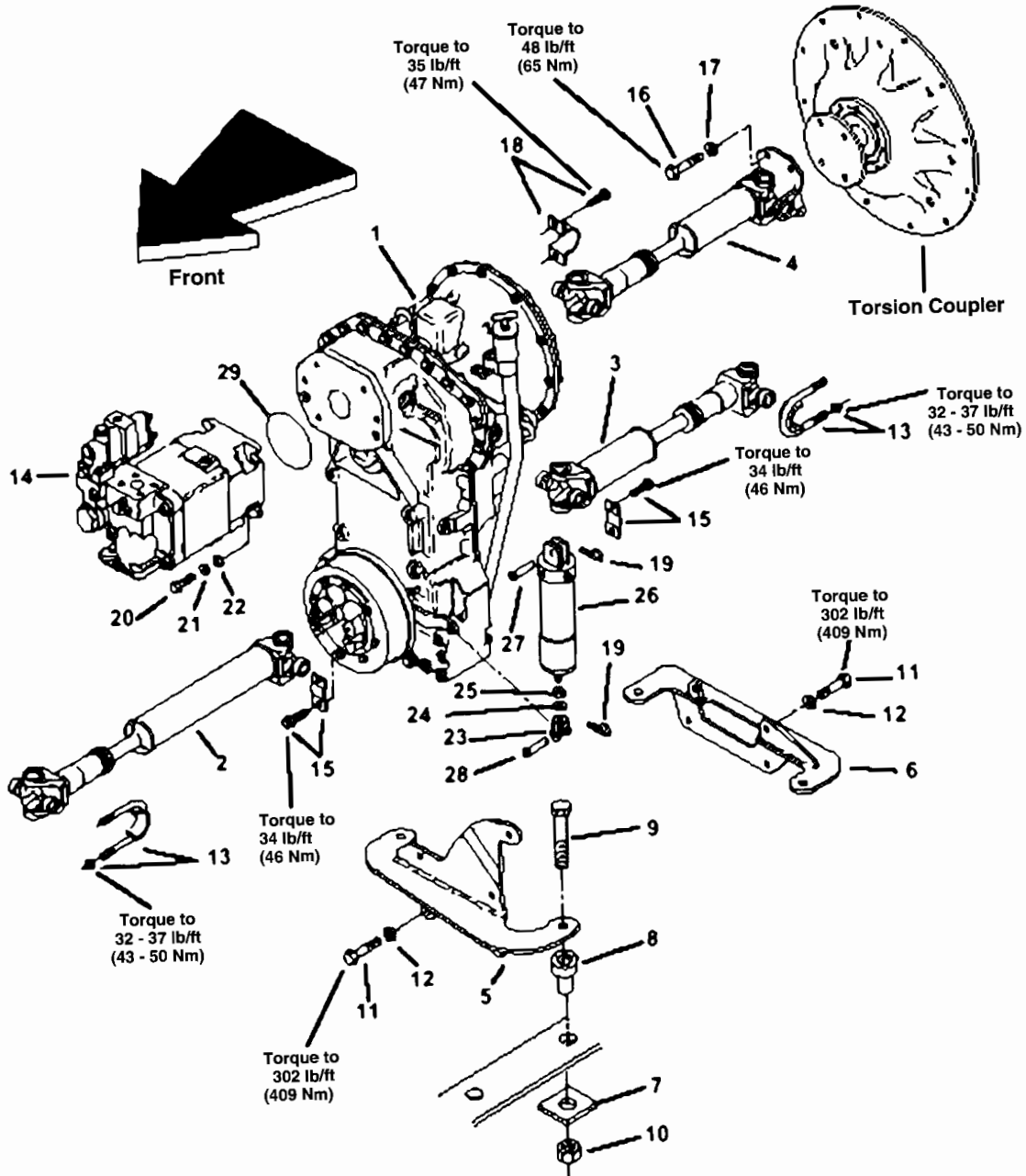

PH1240

SECTION 3 - DRIVE TRAIN

FIGURE 3-27. TRANSMISSION MOUNTING (SN 9909 through 13197)

ITEM	PART NUMBER	QTY	DESCRIPTION	REV
1	8841040	1	Transmission, ZF 4 WG100	
2	7150192	1	Shaft, Drive (Front Axle)	
3	7150182	1	Shaft, Drive (Rear Axle)	
4	7150202	1	Shaft, Drive (Engine Input)	
5	7138186	1	Front Mount, Transmission	
6	7150082	1	Rear Mount, Transmission	
7	7054351	4	Washer, Rebound	
8	8278007	4	Mount, Isolation	
9	8303724	4	HHCS, .75NC x 3.5	
10	8310067	4	Nut, Lock .75NC ESNA	
11	8310427	8	HHCS, M20 x 40mm Long (8.8)	
12	8307047	8	Washer, Lock M20	
13	8882009	4	Assembly, U-Bolt	
14	7138208	1	Pump Assembly	
15	8880218-OM	2	Kit, Strap	
16	8310425	4	HHCS, .438 - 20UNF x 1.25 GR8	
17	8307006	4	Washer, Lock .438	
18	8880219-OM	2	Kit, Fixing 1410	
19	8302470	2	Hair Pin	
20	8303519	4	HHCS, M12 x 40mm Lg 8.8	
21	8307025	4	Washer, Lock M12	
22	8307220	4	Washer, Flat M12	
23	10136599	1	Clevis	
24	10701363	1	Washer, Star	
25	10701562	1	Nut, Lock	
26	7139688	1	Kit, Park Brake Cylinder	
27	10138907	1	Pin, Clevis	
28	10715335	1	Pin, Clevis	
29	8630016	1	O-Ring	

SECTION 3 - DRIVE TRAIN

FIGURE 3-28. DRIVE SHAFT - ENGINE TO TRANSMISSION (Prior to SN 9909)

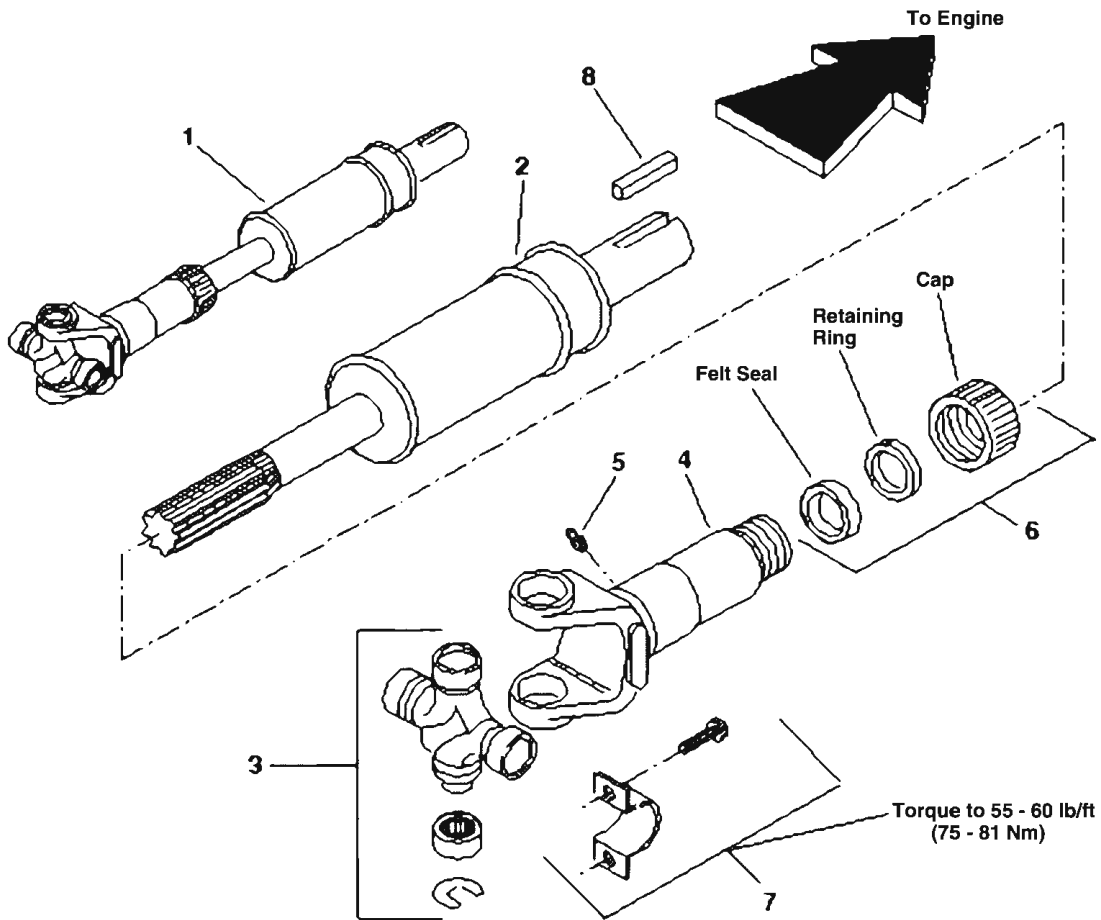

PH0452

SECTION 3 - DRIVE TRAIN

FIGURE 3-28. DRIVE SHAFT - ENGINE TO TRANSMISSION (Prior to SN 9909)

ITEM	PART NUMBER	QTY	DESCRIPTION	REV
1	7096592	1	Drive Shaft - Engine to Transmission (Includes Items 2 thru 6)	
2	8033798	1	Shaft Assembly	
3	8033009	1	Cross and Bearing Assembly	
4	8033797	1	Sleeve Assembly	
5	8033007	1	Fitting, Grease	
6	8033796	1	Package, Seal	
7	8880218-OM	2	Kit, Strap (Each Kit Includes 1 Strap & 2 Screws)	
8	6619261	1	Key, Shaft to Engine	

SECTION 3 - DRIVE TRAIN

FIGURE 3-29. DRIVE SHAFT - ENGINE TO TRANSMISSION (SN 9909 through 13197)

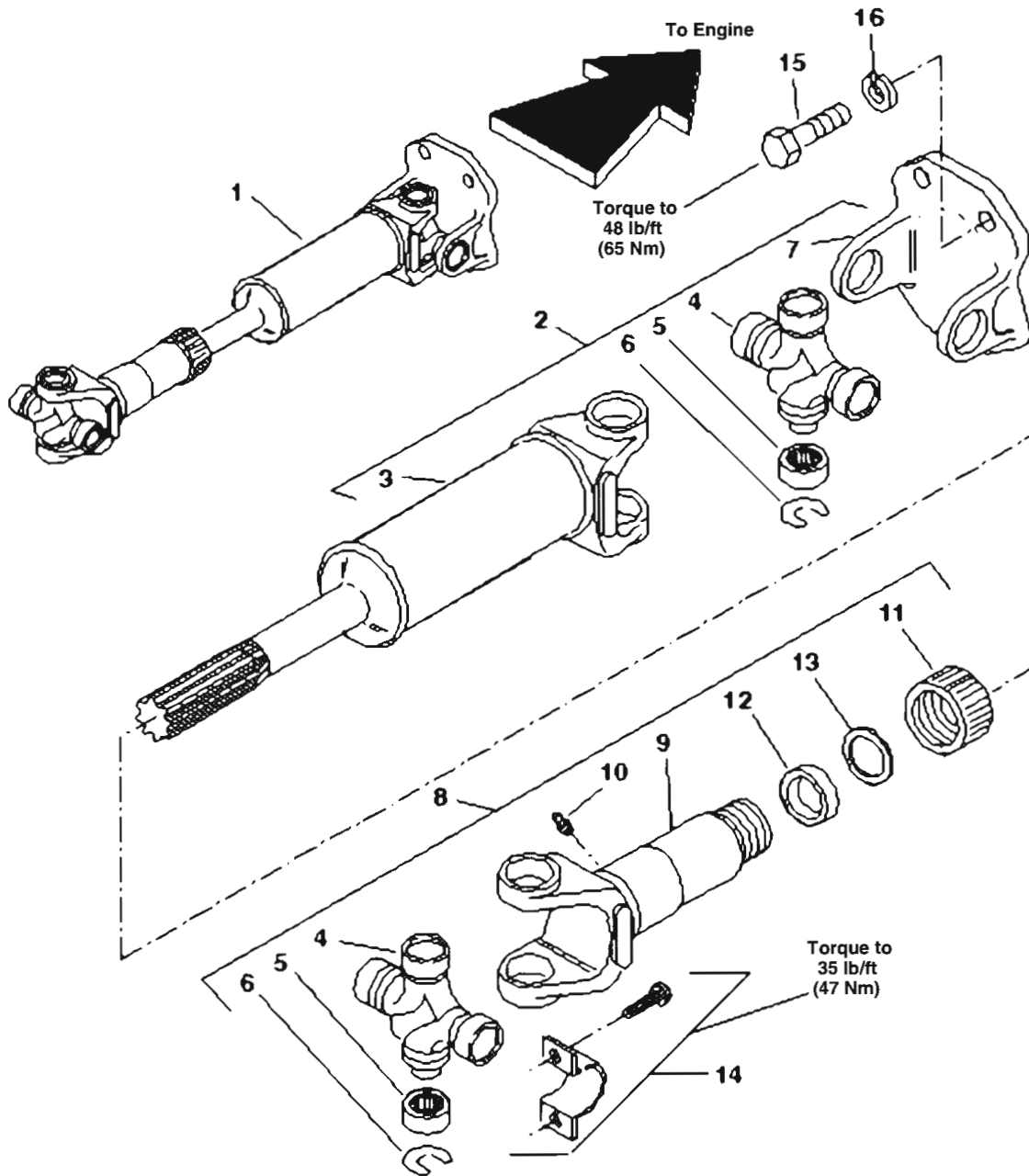

PH2040

SECTION 3 - DRIVE TRAIN

FIGURE 3-29. DRIVE SHAFT - ENGINE TO TRANSMISSION (SN 9909 through 13197)

ITEM	PART NUMBER	QTY	DESCRIPTION	REV
1	7150202	1	Drive Shaft - Engine to Transmission (Includes Items 2 thru 13)	
2	8035618	1	Tight Joint Assembly (Includes Items 3 thru 7)	
3	8034593	1	Shaft Assembly	
4	8035620	2	Cross	
5	8035621	8	Bearing	
6	8035622	8	Snap Ring	
7	8033652	1	Flange Yoke	
8	8035617	1	Slip Joint Assembly (Includes Items 4 thru 6 & 9 thru 13)	
9	8033003	1	Slip Yoke	
10	8033004	1	Fitting, Grease	
11	8035623	1	Cap, Dust	
12	8035624	1	Seal	
13	8035625	1	Washer	
14	8880219-OM	2	Kit, Strap (Each Kit Includes 1 Strap & 2 Screws)	
15	8310425	4	HHCS, 7/16-20UNF x 1.25 Gr.8	
16	8307006	4	Washer, Lock 7/16	

SECTION 3 - DRIVE TRAIN

FIGURE 3-30. DRIVE SHAFT - FRONT AND REAR (Prior to SN 9909)

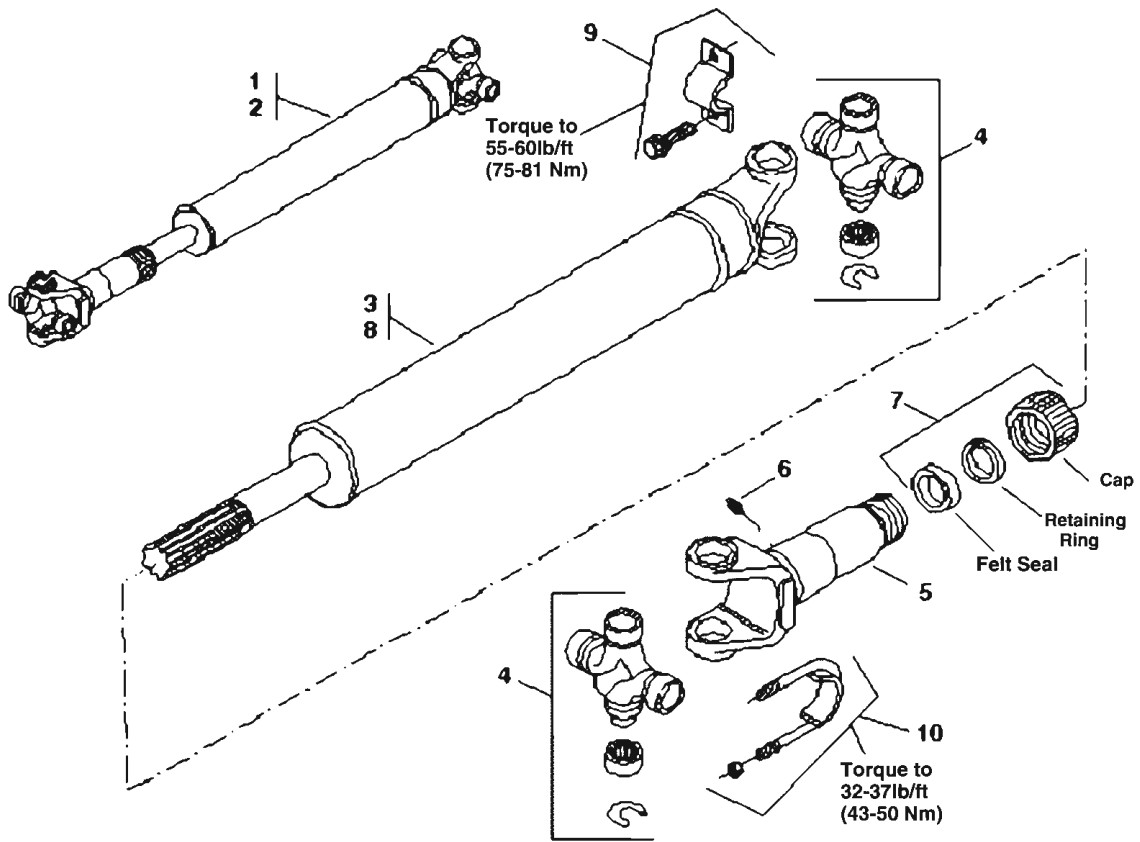

PH0421

SECTION 3 - DRIVE TRAIN

FIGURE 3-30. DRIVE SHAFT - FRONT AND REAR (Prior to SN 9909)

ITEM	PART NUMBER	QTY	DESCRIPTION	REV
1	7096632	1	Drive Shaft - Front Axle (Includes Items 3 thru 7)	
2	7099832	1	Drive Shaft - Rear Axle (Includes Items 4 thru 8)	
		Ref	NOTE: Quantities Listed Below Are For One Drive Shaft Assembly	
3	8033097	1	Shaft Assembly - Front Axle	
4	8033009	2	Cross and Bearing Assembly	
5	8033006	1	Sleeve Assembly	
6	8033007	1	Fitting, Grease	
7	8033008	1	Seal Package	
8	8033098	1	Shaft Assembly - Rear Axle	
9	8880218-OM	2	KIT, STRAP, DANA,1480	
10	8882009	2	U-Bolt Assembly	

SECTION 3 - DRIVE TRAIN

FIGURE 3-31. DRIVE SHAFT - FRONT AND REAR (SN 9909 through 13197)

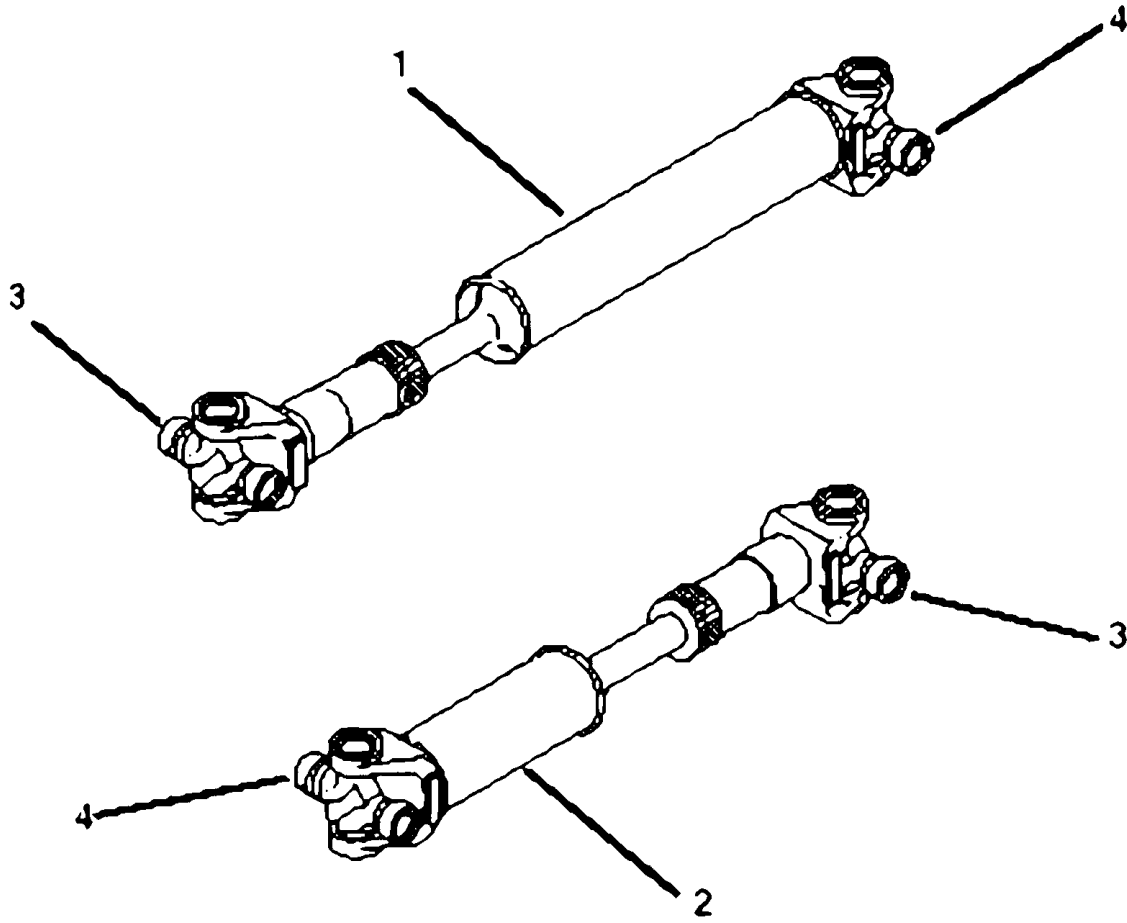

SECTION 3 - DRIVE TRAIN

FIGURE 3-31. DRIVE SHAFT - FRONT AND REAR (SN 9909 through 13197)

ITEM	PART NUMBER	QTY	DESCRIPTION	REV
1	7150192	1	Drive Shaft - Front (Includes Items 3 & 4)	
2	7150182	1	Drive Shaft - Rear (Includes Items 3 & 4)	
3	8035773	2	Cross and Bearing Kit	
4	N.S.S.	2	Cross and Bearing Kit, (no longer available, order complete drive shaft)	

SECTION 3 - DRIVE TRAIN

FIGURE 3-32. DIFFERENTIAL CARRIER ASSEMBLY

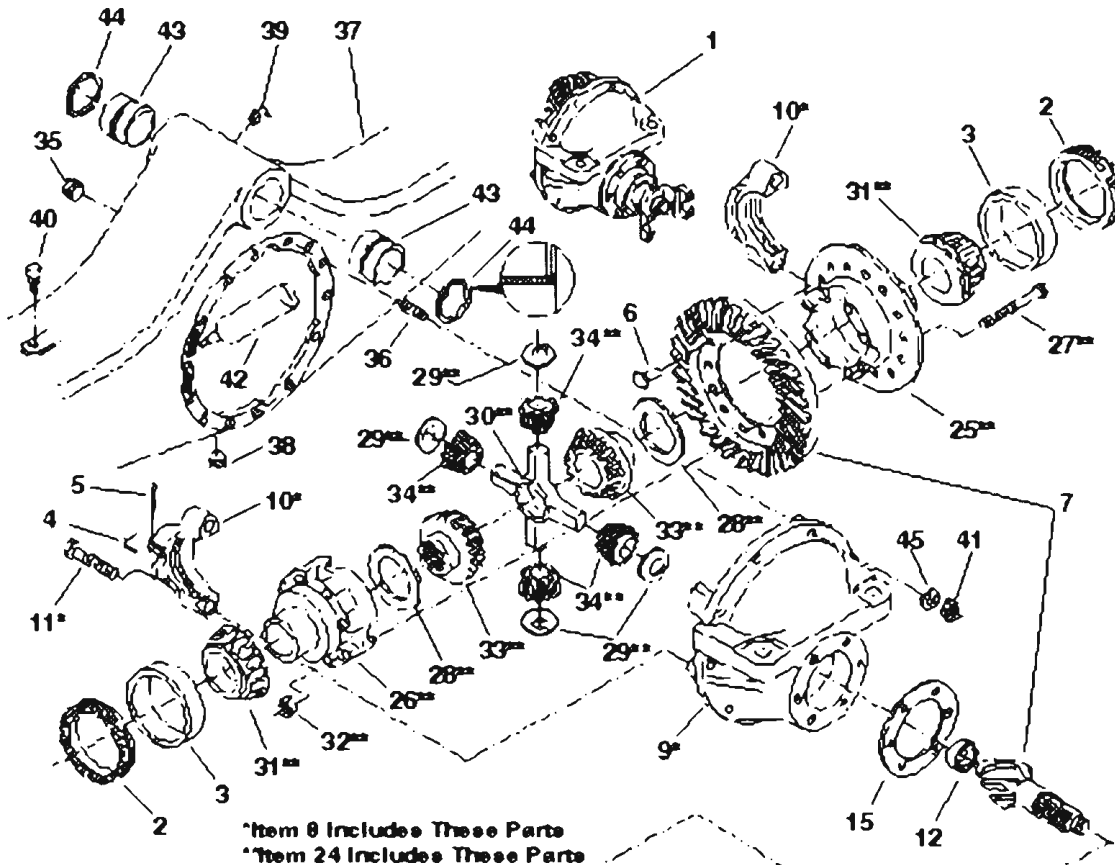

*Item 8 Includes These Parts
 *Item 24 Includes These Parts

ITEM 14 SPACER, PINION BEARING CHART		
PART NO.	THICKNESS	
8004508	.5135	
8004507	.5185	
8004506	.5195	
8004509	.5225	
8004510	.5245	
8004511	.5255	
8004512	.5285	
8004513	.5275	
8004514	.5285	
8004515	.5295	
8004518	.5305	
8004517	.5315	
8004518	.5325	
8004519	.5335	
8004520	.5345	
8004521	.5355	
8004522	.5375	
8004523	.5395	
8004524	.5405	
8004525	.5435	
8004528	.5485	

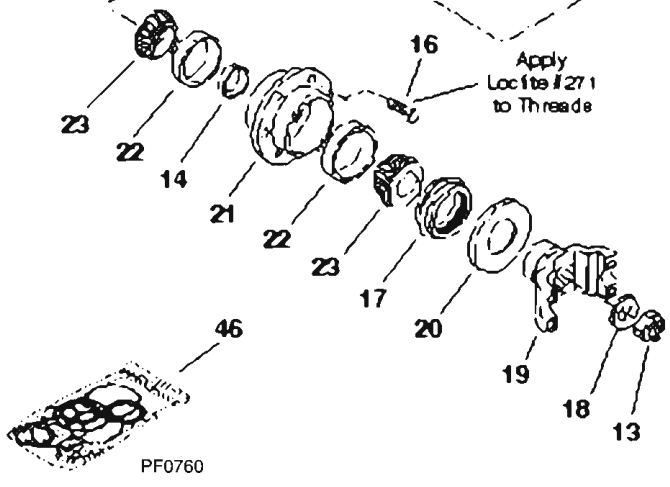

PH0261

SECTION 3 - DRIVE TRAIN

FIGURE 3-32. DIFFERENTIAL CARRIER ASSEMBLY

ITEM	PART NUMBER	QTY	DESCRIPTION	REV
1	NLA	1	Differential Carrier Assembly (Includes Items 2 thru 34)	
2	8033967	2	Ring, Adjusting	
3	8033968	2	Cup, Roller Bearing	
4	8033969	2	Lock, Bearing Adjusting Ring	
5	8033970	2	Pin, Cotter	
6	10724869	14	Rivet (Solid)	
7	NLA	1	Gear and Pinion Assembly (Matched Set)	
8	8033973	1	Carrier Assembly (Includes Items 9 thru 11)	
9	N.S.S.	1	Carrier	
10	N.S.S.	2	Cap, Differential Bearing	
11	8033974	4	Bolt, Hex	
12	8033975	1	Bearing Assembly	
13	8033810	1	Nut, Pinion (See Kits)	
14	See Chart	1	Spacer, Pinion Bearing	
15	8033976	AR	Shim, .010in	
15	8033977	AR	Shim, .030in	
15	8033978	AR	Shim, .005in	
16	8033979	6	Bolt, Hex	
17	8033806	1	Seal, Oil (See Kits)	
18	8033980	1	Washer	
19	8033981	1	End Yoke Assembly (Includes Item 20)	
20	10836774	1	Slinger, Dust	
21	8033983	1	Cap Assembly, Bearing Retainer (Includes Item 22)	
22	8033984	2	Cup, Roller Bearing	
23	8033985	2	Cone, Roller Bearing	
24	8033986	1	Differential Case Assembly (Includes Items 25 thru 34)	
25	8033987	1	Flange Half, Differential Case	
26	8033988	1	Cap Half, Differential Case	
27	8033989	8	Bolt	
28	8033990	2	Washer, Thrust (Differential Gear)	
29	8033991	4	Washer, Thrust (Differential Pinion)	
30	NLA	1	Shaft, Differential Cross	
31	10724832	2	Cone, Roller Bearing	
32	8033994	8	Nut, Lock	
33	8033995	2	Gear, Differential	
34	8033996	4	Pinion, Differential	
35	8033997	1	Plug, Pipe	
36	10713833	6	Stud, Dowel (2in O.A.L.)	
36	8033999	2	Stud, Dowel (2.38in O.A.L.)	
36	8034500	2	Stud, Dowel (2.81in O.A.L.)	
37	8034501	1	Housing, Axle	
38	8032895	1	Plug, Magnetic Pipe	
39	8034502	1	Grease Fitting	
40	8033228	1	Breather	
41	8034503	10	Nut, Flange Lock	
42	8526044	1	Cartridge, Gasket Eliminator 10.15 fl oz	
43	8034504	2	Bushing, Axle Pivot	
44	8033809	2	Seal, Oil - Pivot Pin (See Kits)	
45	8034505	10	Washer, Flat	
		Ref	KITS	

SECTION 3 - DRIVE TRAIN

ITEM	PART NUMBER	QTY	DESCRIPTION	REV
46	8033802	1	Seal Kit, Axle (Includes the following Items which contains enough seals to service one complete axle)	
46		Ref	Oil Seal - Pinion (Item 17)	
46		Ref	Oil Seal - Pivot Pin (Item 44)	
46		Ref	Nut, Pinion (Item 13)	
46		Ref	Oil Seal - Axle Shaft (Item 7, AXLE STEERING JOINTS)	
46		Ref	Oil Seal - King Pin (Item 18, AXLE STEERING JOINTS)	
46		Ref	Oil Seal - Wheel Hub (Item 44, AXLE WHEEL ENDS)	
46		Ref	Oil Seal - Spindle (Item 31, AXLE WHEEL ENDS)	
46		Ref	Seal Kit - Wet Brake (See Kits, AXLE WHEEL ENDS)	

SECTION 3 - DRIVE TRAIN

FIGURE 3-33. AXLE STEERING JOINTS

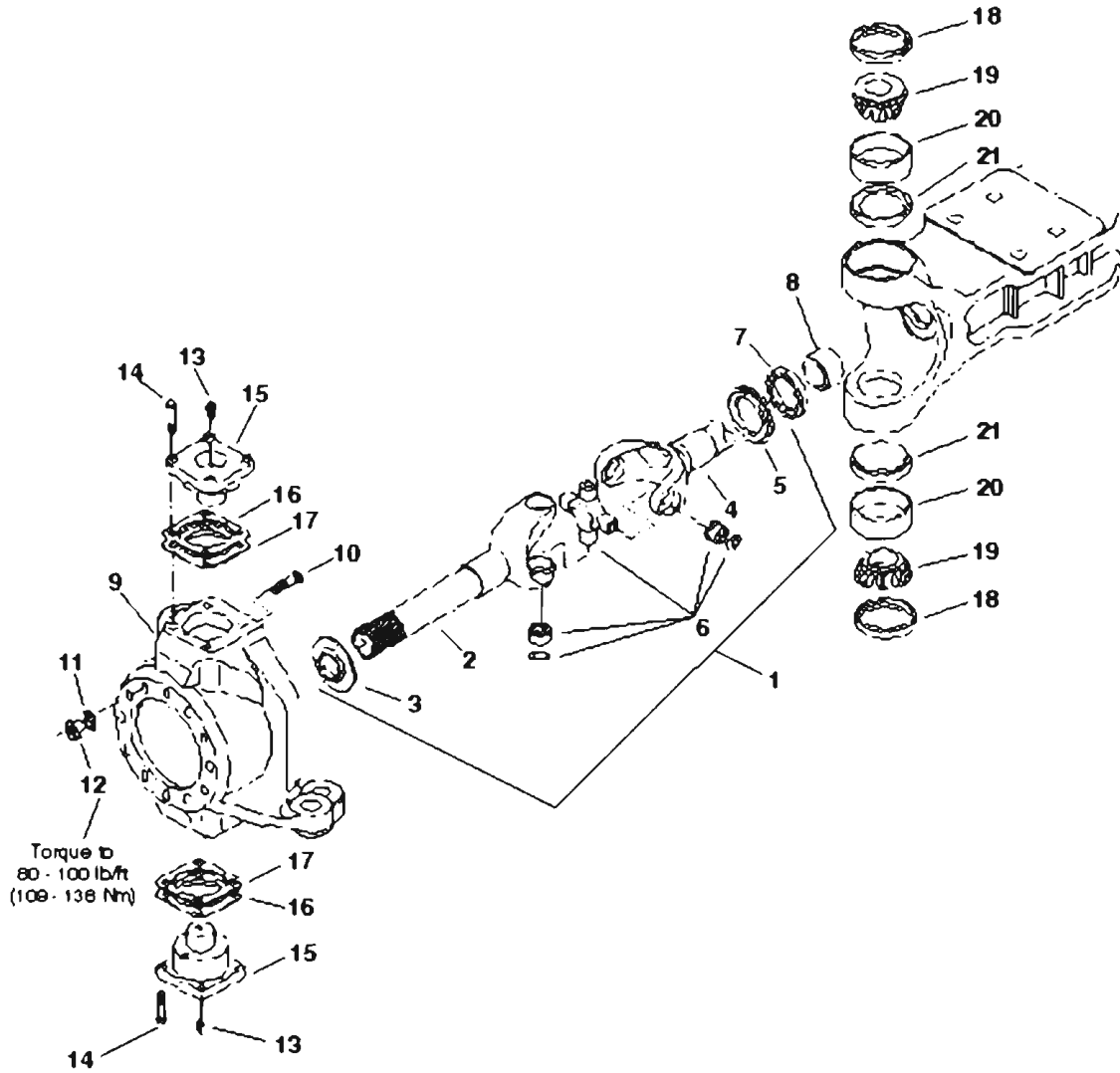

PH0270

SECTION 3 - DRIVE TRAIN

FIGURE 3-33. AXLE STEERING JOINTS

ITEM	PART NUMBER	QTY	DESCRIPTION	REV
		Ref	NOTE: Quantities are for one axle.	
1	8033815	2	Shaft and Joint Assembly, Front and Rear Axles (Includes Items 2 thru 6)	
2	8033816	1	Shaft, Outer	
3	8033817	1	Slinger, Dust (Outer)	
4	8033818	1	Shaft, Inner	
5	8033805	1	Slinger, Dust (Inner)	
6	8033009	1	Cross and Bearing Kit	
7	8033804	2	Seal, Oil - Axle Shaft (See Kits DIFFERENTIAL CARRIER ASSEMBLY for Breakdown)	
8	8033820	2	Bushing	
9	8033821	1	Knuckle Assembly, Left Front, Right Rear (Includes Item 10)	
9	8033822	1	Knuckle Assembly, Not Shown, Right Front, Left Rear (Includes Item 10)	
10	8033823	24	Stud, Dowell	
11	8032876	24	Washer, Flat	
12	8032875	24	Nut, Lock	
13	8032877	4	Grease Fitting	
14	8033824	16	HHCS, Hex Head	
15	8032880	4	Cap, King Pin	
16	8032881	AR	Shim, Formed	
17	8032882	AR	Shim, Formed	
18	8032979	4	Seal, Oil - King Pin (See Kits DIFFERENTIAL CARRIER ASSEMBLY for Breakdown)	
19	10725149	4	Cone, Roller Bearing	
20	8032885	4	Cup, Roller Bearing	
21	8032886	4	Retainer, Grease	

SECTION 3 - DRIVE TRAIN

FIGURE 3-34. AXLE WHEEL ENDS (Prior to SN 0461)

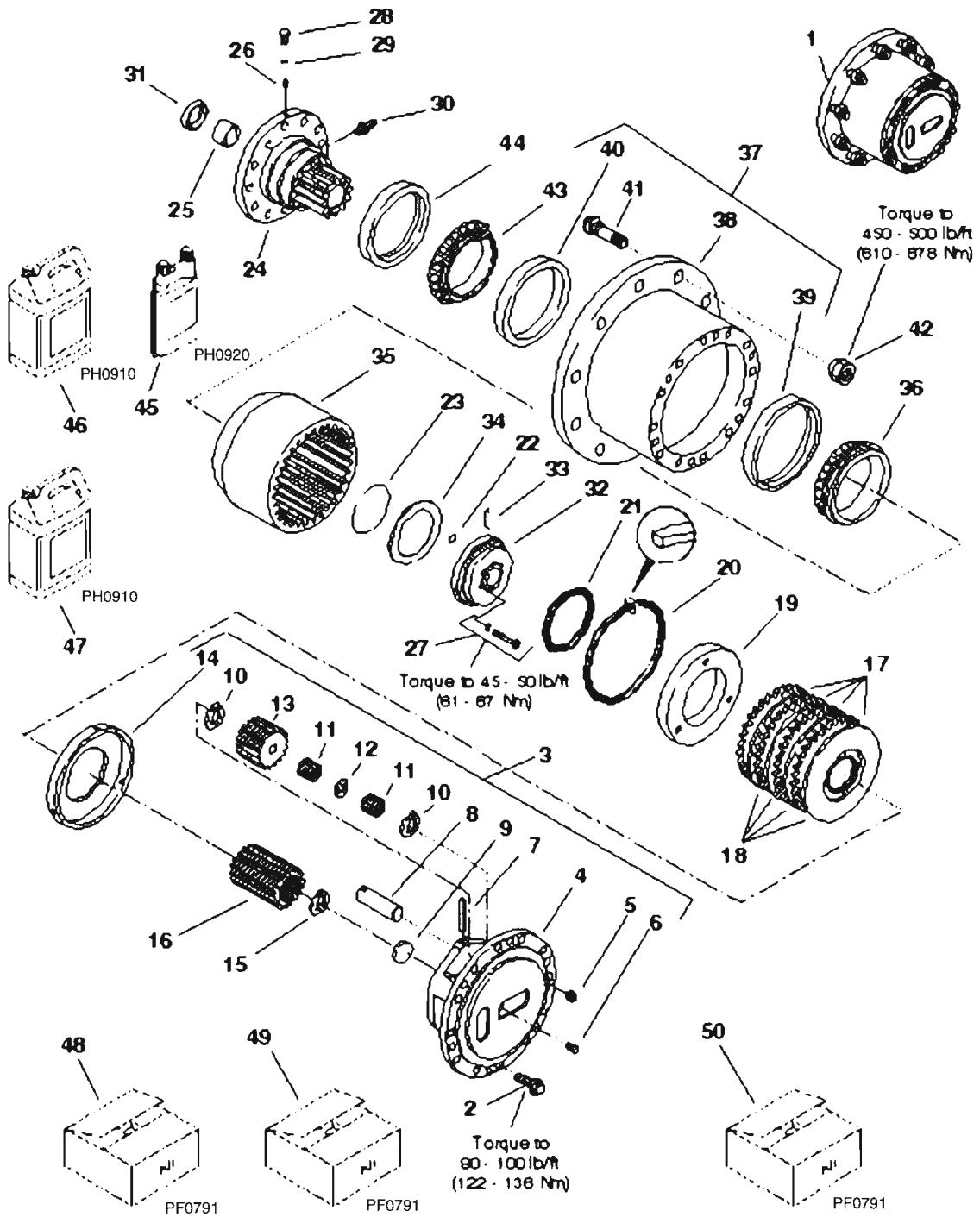

PH0642

SECTION 3 - DRIVE TRAIN

FIGURE 3-34. AXLE WHEEL ENDS (Prior to SN 0461)

ITEM	PART NUMBER	QTY	DESCRIPTION	REV
		Ref	NOTE: Quantities are for one wheel end assembly unless otherwise specified.	
1	8034814	1	Wheel End Assembly, Front and Rear (Includes Items 2 thru 44)	
2	8032906	18	Screw, Hex Hd, Self Locking	
3	8033012	1	Planetary Gear Assembly (Includes Items 4 thru 14)	
4	8032903	1	Flange, Planetary Drive	
5	8032895	1	Plug, Pipe	
6	8032894	1	Plug, Hex Hd	
7	8032900	3	Pin, Roll	
8	8032899	3	Shaft, Planet Gear	
9	8032896	1	Washer, Drive Flange	
10	8032901	6	Washer, Keyed	
11	8032898	150	Bearing, Single Roller	
12	8032897	3	Washer, Planet Gear	
13	8032902	3	Gear, Spur	
14	8032904	1	Plate, Lining Stop	
15	8033826	1	Ring, Snap	
16	8033827	1	Gear, Spur	
17	N.S.S.	4	Plate, Lining Stop (See Kits)	
18	N.S.S.	4	Disc Assembly (See Kits)	
19	8032912	1	Piston	
20	8034692	1	O-Ring (See Kits)	
21	8034693	1	O-Ring (See Kits)	
22	8032922	2	O-Ring (See Kits)	
23	8032923	1	O-Ring (See Kits)	
24	See Kits	1	Spindle Assembly (Includes Items 25 & 26), Note: Identify bolt size before ordering. (If 3/8in order similar parts on this page.) (If 1/2in order similar parts on AXLE WHEEL ENDS)	
25	8033828	1	Bushing, Spindle	
26	8032826	2	Seat, Insert	
27	8034581	1	Screw and Washer Kit (Includes six screws and six washers), Note: Identify bolt size before ordering. (If 3/8in order similar parts on this page.) (If 1/2in order similar parts on AXLE WHEEL ENDS)	
28	8032984	1	Plug, Bleeder	
29	8032985	1	O-Ring, Bleeder Plug	
30	8033829	1	Fitting, Brake	
31	8033803	1	Seal, Oil - Spindle (See Kits DIFFERENTIAL CARRIER ASSEMBLY for Breakdown)	
32	8032920	1	Retainer, Bearing Adjusting Ring (Includes Item 33), Note: Identify bolt size before ordering. (If 3/8in order similar parts on this page.) (If 1/2in order similar parts on AXLE WHEEL ENDS)	
33	8032949	1	Tubing, Brake	
34	8032972	AR	Shim, Adjusting (.010in)	
34	8035268	AR	Shim, Adjusting (.011in)	
34	8035269	AR	Shim, Adjusting (.012in)	
34	8035270	AR	Shim, Adjusting (.013in)	
34	8035271	AR	Shim, Adjusting (.014in)	
34	8035272	AR	Shim, Adjusting (.015in)	
34	8032973	AR	Shim, Adjusting (.020in)	
34	8032974	AR	Shim, Adjusting (.030in)	
35	8032910	1	Gear, Planetary Ring	

SECTION 3 - DRIVE TRAIN

ITEM	PART NUMBER	QTY	DESCRIPTION	REV
36	8032913	1	Cone, Roller	
37	8033831	1	Hub Assembly (Includes Items 38 thru 41)	
38	8033832	1	Hub, Planetary	
39	8032891	1	Cup, Roller Bearing	
40	8032892	1	Cup, Roller Bearing	
41	8032893	10	Bolt, Wheel, Right Side	
42	8786516	10	Nut, Wheel	
43	8032914	1	Cone, Roller Bearing	
44	8032983	1	Seal, Oil - Wheel Hub (See Kits DIFFERENTIAL CARRIER ASSEMBLY for Breakdown)	
45	8522043	1	Friction Modifier Fluid (Low Odor) - 32 Oz (enough to service 4 wheel ends)	
46	8522045	1	Wheel End Oil 2-1/2 Gal (enough to service 4 wheel ends)	
47	8522048	1	Wheel End Oil 1 Gal	
		Ref	KITS	
48	8034688	1	Brake Kit (Includes Items 17 thru 18) (this kit services one wheel end)	
49	8034819	1	Wet Brake Seal Kit (Includes Items 20 thru 23)	
50	8033799	1	Spindle Kit (Includes Items 24 thru 27), Note: Identify bolt size before ordering. (If 3/8in order similar parts on this page.) (If 1/2in order similar parts on AXLE WHEEL ENDS)	

SECTION 3 - DRIVE TRAIN

FIGURE 3-35. AXLE WHEEL ENDS (SN 0461 through 13197)

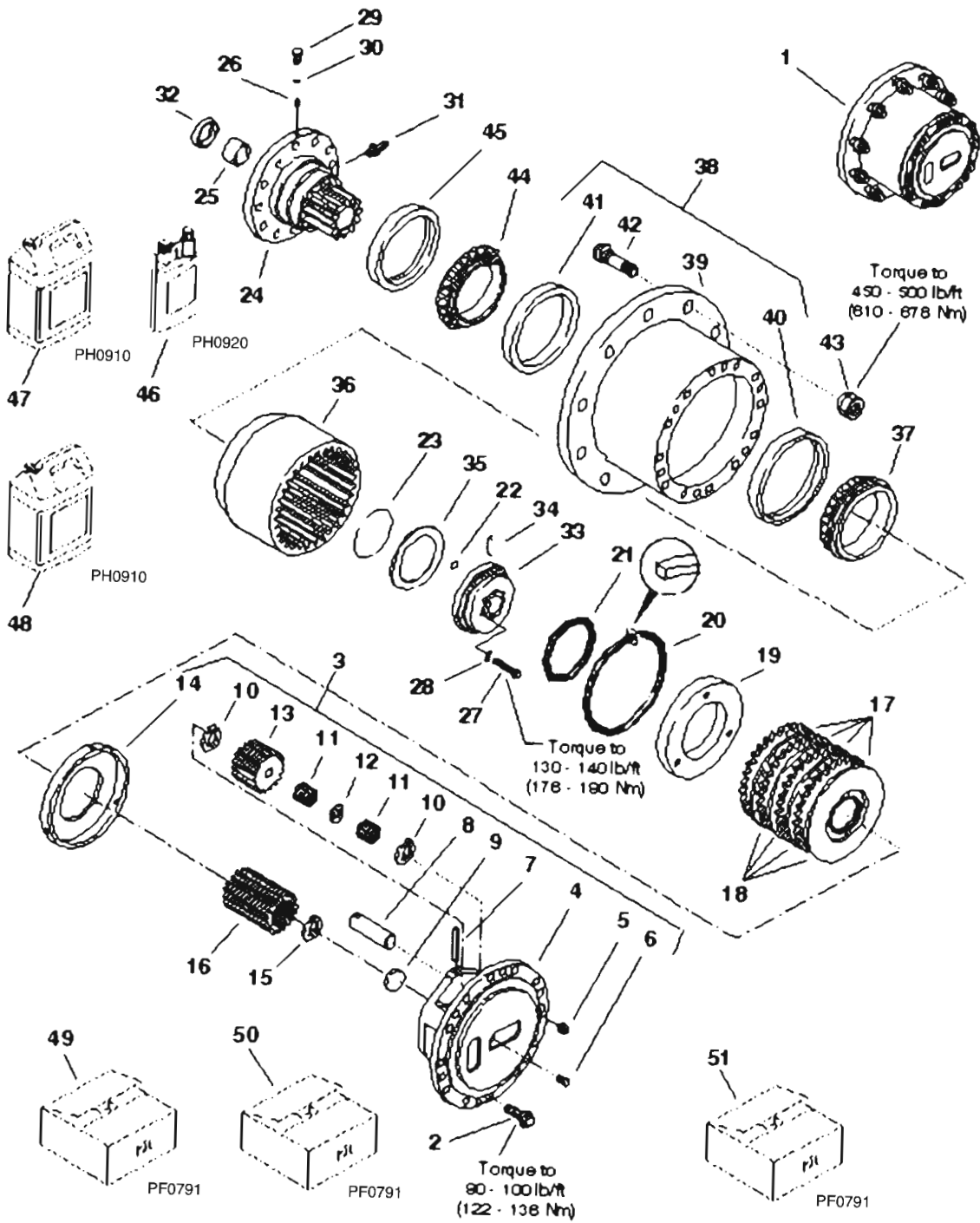

PH0643

SECTION 3 - DRIVE TRAIN

FIGURE 3-35. AXLE WHEEL ENDS (SN 0461 through 13197)

ITEM	PART NUMBER	QTY	DESCRIPTION	REV
		Ref	NOTE: Quantities are for one wheel end assembly unless otherwise specified.	
1	8034814	1	Wheel End Assembly, Front and Rear (Includes Items 2 thru 45)	
2	8032906	18	Screw, Hex Hd, Self Locking	
3	8033012	1	Planetary Gear Assembly (Includes Items 4 thru 14)	
4	8032903	1	Flange, Planetary Drive	
5	8032895	1	Plug, Pipe	
6	8032894	1	Plug, Hex Hd	
7	8032900	3	Pin, Roll	
8	8032899	3	Shaft, Planet Gear	
9	8032896	1	Washer, Drive Flange	
10	8032901	6	Washer, Keyed	
11	8032898	150	Bearing, Single Roller	
12	8032897	3	Washer, Planet Gear	
13	8032902	3	Gear, Spur	
14	8032904	1	Plate, Lining Stop	
15	8033826	1	Ring, Snap	
16	8033827	1	Gear, Spur	
17	N.S.S.	4	Plate, Lining Stop (See Kits)	
18	N.S.S.	4	Disc Assembly (See Kits)	
19	8032912	1	Piston	
20	8034692	1	O-Ring (See Kits)	
21	8034693	1	O-Ring (See Kits)	
22	8032922	2	O-Ring (See Kits)	
23	8032923	1	O-Ring (See Kits)	
24	See Kits	1	Spindle Assembly (Includes Items 25 & 26)	
25	8033828	1	Bushing, Spindle	
26	8032826	2	Seat, Insert	
27	8034584	6	Screw, 12 Point Cap - 1/2in	
28	8034585	6	Washer, Flat Hardened 1/2in	
29	8032984	1	Plug, Bleeder	
30	8032985	1	O-Ring, Bleeder Plug	
31	8033829	1	Fitting, Brake	
32	8033803	1	Seal, Oil - Spindle (See Kits DIFFERENTIAL CARRIER ASSEMBLY for Breakdown)	
33	8034586	1	Retainer, Bearing Adjusting Ring (Includes Item 34)	
34	8032949	1	Tubing, Brake	
35	8032972	AR	Shim, Adjusting (.010in)	
35	8035268	AR	Shim, Adjusting (.011in)	
35	8035269	AR	Shim, Adjusting (.012in)	
35	8035270	AR	Shim, Adjusting (.013in)	
35	8035271	AR	Shim, Adjusting (.014in)	
35	8035272	AR	Shim, Adjusting (.015in)	
35	8032973	AR	Shim, Adjusting (.020in)	
35	8032974	AR	Shim, Adjusting (.030in)	
36	8032910	1	Gear, Planetary Ring	
37	8032913	1	Cone, Roller	
38	8033831	1	Hub Assembly (Includes Items 39 thru 42)	
39	8033832	1	Hub, Planetary	
40	8032891	1	Cup, Roller Bearing	

SECTION 3 - DRIVE TRAIN

ITEM	PART NUMBER	QTY	DESCRIPTION	REV
41	8032892	1	Cup, Roller Bearing	
42	8032893	10	Bolt, Wheel, Right Side	
43	8786516	10	Nut, Wheel	
44	8032914	1	Cone, Roller Bearing	
45	8032983	1	Seal, Oil - Wheel Hub (See Kits DIFFERENTIAL CARRIER ASSEMBLY for Breakdown)	
46	8522043	1	Friction Modifier Fluid (Low Odor) 32 Oz (enough to service 4 wheel ends)	
47	8522045	1	Wheel End Oil 2-1/2 Gal (enough to service 4 wheel ends)	
48	8522048	1	Wheel End Oil 1 Gal	
		Ref	KITS	
49	8034688	1	Brake Kit (Includes Items 17 & 18) (this kit services one wheel end)	
50	8034819	1	Wet Brake Seal Kit (Includes Items 20 thru 23)	
51	8034590	1	Service Kit, Spindle (Includes Items 24 thru 27)	

SECTION 3 - DRIVE TRAIN

FIGURE 3-36. TIE ROD AND STEERING CYLINDER MOUNTING

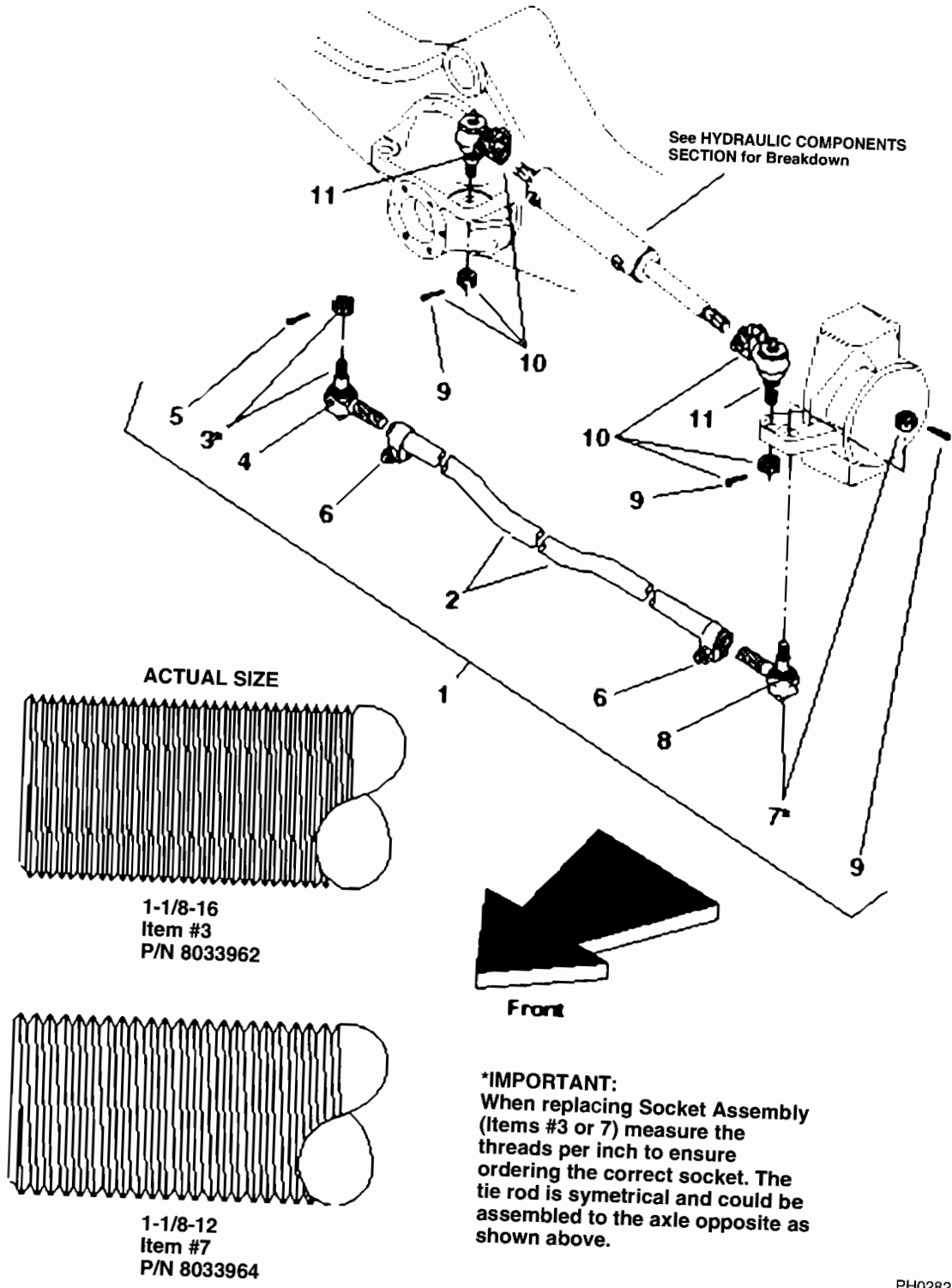

PH0282

SECTION 3 - DRIVE TRAIN

FIGURE 3-36. TIE ROD AND STEERING CYLINDER MOUNTING

ITEM	PART NUMBER	QTY	DESCRIPTION	REV
		Ref	NOTE: Quantities listed are for one axle.	
1	8033960	1	Tie Rod Assembly (Includes Items 2 thru 9)	
2	8033961	1	Tube, Tie Rod	
3	8033962	1	Socket Assembly, 1-1/8 - 16 RH Thread (Includes nut, cotter pin and boot) See "IMPORTANT" Note	
4	8033963	1	Boot	
5	8033965	1	Cotter Pin	
6	8032930	2	Clamp Assembly	
7	8033964	1	Socket Assembly, 1-1/8 - 12 RH Thread (Includes nut, cotter pin and boot) See "IMPORTANT" Note	
8	8033963	1	Boot	
9	8033965	3	Cotter Pin	
10	8340025	2	Socket Assembly, Steer Cylinder (Includes nut, cotter pin and boot)	
11	8032816	AR	Boot	

SECTION 3 - DRIVE TRAIN

FIGURE 3-37. WHEELS AND TIRES - 8042

Warning
 Mis-matched tire sizes or mixing of tire types (Radial and Bias ply) may compromise vehicle stability and may result in vehicle tipover.

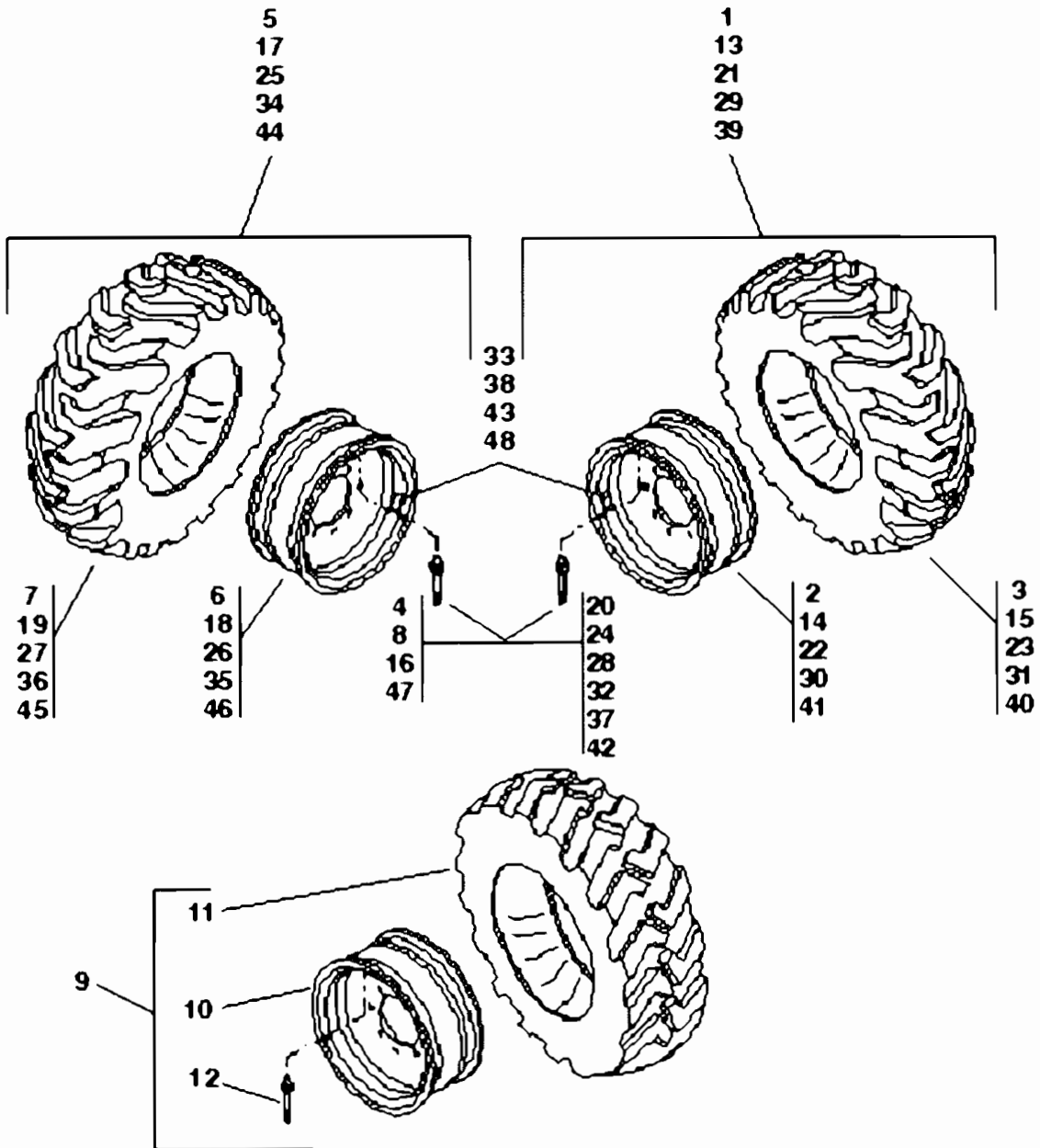

PH0461

SECTION 3 - DRIVE TRAIN

FIGURE 3-37. WHEELS AND TIRES - 8042

ITEM	PART NUMBER	QTY	DESCRIPTION	REV
1	7119642	2	Tire and Wheel Ass'y, Right Side - 13.00 x 24, 12 Ply (Includes Items 2 thru 4)	
2	7092533	1	Wheel, 9024 GR	
3	8780031	1	Tire, 13.00 x 24, 12 Ply	
4	8786514	1	Stem, Valve	
5	7119632	2	Tire and Wheel Ass'y, Left Side - 13.00 x 24, 12 Ply (Includes Items 6 thru 8)	
6	7092533	1	Wheel, 9024 GR	
7	8780031	1	Tire, 13.00 x 24, 12 Ply	
8	8786514	1	Stem, Valve	
9	7092612	4	Tire and Wheel Ass'y, Left or Right Side - 13.00 R24, 14 Ply (Includes Items 10 thru 12)	
10	7092533	1	Wheel, 9024 GR	
11	8780264	1	Tire, 13.00 R24 Radial	
12	8786514	1	Stem, Valve	
13	7110772	2	Tire and Wheel Ass'y, Right Side - 15.5 x 25, 12 Ply (Includes Items 14 thru 16)	
14	7098733	1	Wheel, 1325LR x 1.5 Offset	
15	8780036	1	Tire, 15.5 x 25, 12 Ply	
16	8786514	1	Stem, Valve	
17	7110762	2	Tire and Wheel Ass'y, Left Side - 15.5 x 25, 12 Ply (Includes Items 18 thru 20)	
18	7098733	1	Wheel, 1325LR x 1.5 Offset	
19	8780036	1	Tire, 15.5 x 25, 12 Ply	
20	8786514	1	Stem, Valve	
21	7099532	2	Tire and Wheel Ass'y, Right Side - 17.5 x 25, 12 Ply (Includes Items 22 thru 24)	
22	7098733	1	Wheel, 1325LR x 1.5 Offset	
23	8780037	1	Tire, 17.5 x 25, 12 Ply	
24	8786514	1	Stem, Valve	
25	7099522	2	Tire and Wheel Ass'y, Left Side - 17.5 x 25, 12 Ply (Includes Items 26 thru 28)	
26	7098733	1	Wheel, 1325LR x 1.5 Offset	
27	8780037	1	Tire, 17.5 x 25, 12 Ply	
28	8786514	1	Stem, Valve	
29	7119662	2	Tire and Wheel Ass'y, Right Side - 13.00 x 24, 12 Ply with Trak Seal (Includes Items 30 thru 32)	
30	7092533	1	Wheel, 9024 GR	
31	8780031	1	Tire, 13.00 x 24, 12 Ply	
32	8786514	1	Stem, Valve	
33	4108161	1	Label, Hydrofill	
34	7119652	2	Tire and Wheel Ass'y, Left Side - 13.00 x 24, 12 Ply with Trak Sea (Includes Items 35 thru 38)	
35	7092533	1	Wheel, 9024 GR	
36	8780031	1	Tire, 13.00 x 24, 12 Ply	
37	8786514	1	Stem, Valve	
38	4108161	1	Label, Hydrofill	
39	7138240	2	Tire and Wheel Ass'y, Right Side - 13.00 x 24, 12 Ply "Yokohama" (Includes Items 40 thru 43)	
40	8780045	1	Tire, 13.00 x 24, 12 Ply	
41	7092533	1	Wheel, 9024 GR	
42	8786514	1	Stem, Valve	

SECTION 3 - DRIVE TRAIN

ITEM	PART NUMBER	QTY	DESCRIPTION	REV
43	4108161	1	Label, Hydrofill	
44	7138241	2	Tire and Wheel Ass'y, Left Side - 13.00 x 24, 12 Ply "Yokohama" (Includes Items 45 thru 48)	
45	8780045	1	Tire, 13.00 x 24, 12 Ply	
46	7092533	1	Wheel, 9024 GR	
47	8786514	1	Stem, Valve	
48	4108161	1	Label, Hydrofill	

SECTION 3 - DRIVE TRAIN

FIGURE 3-38. WHEELS AND TIRES - 10042/10054

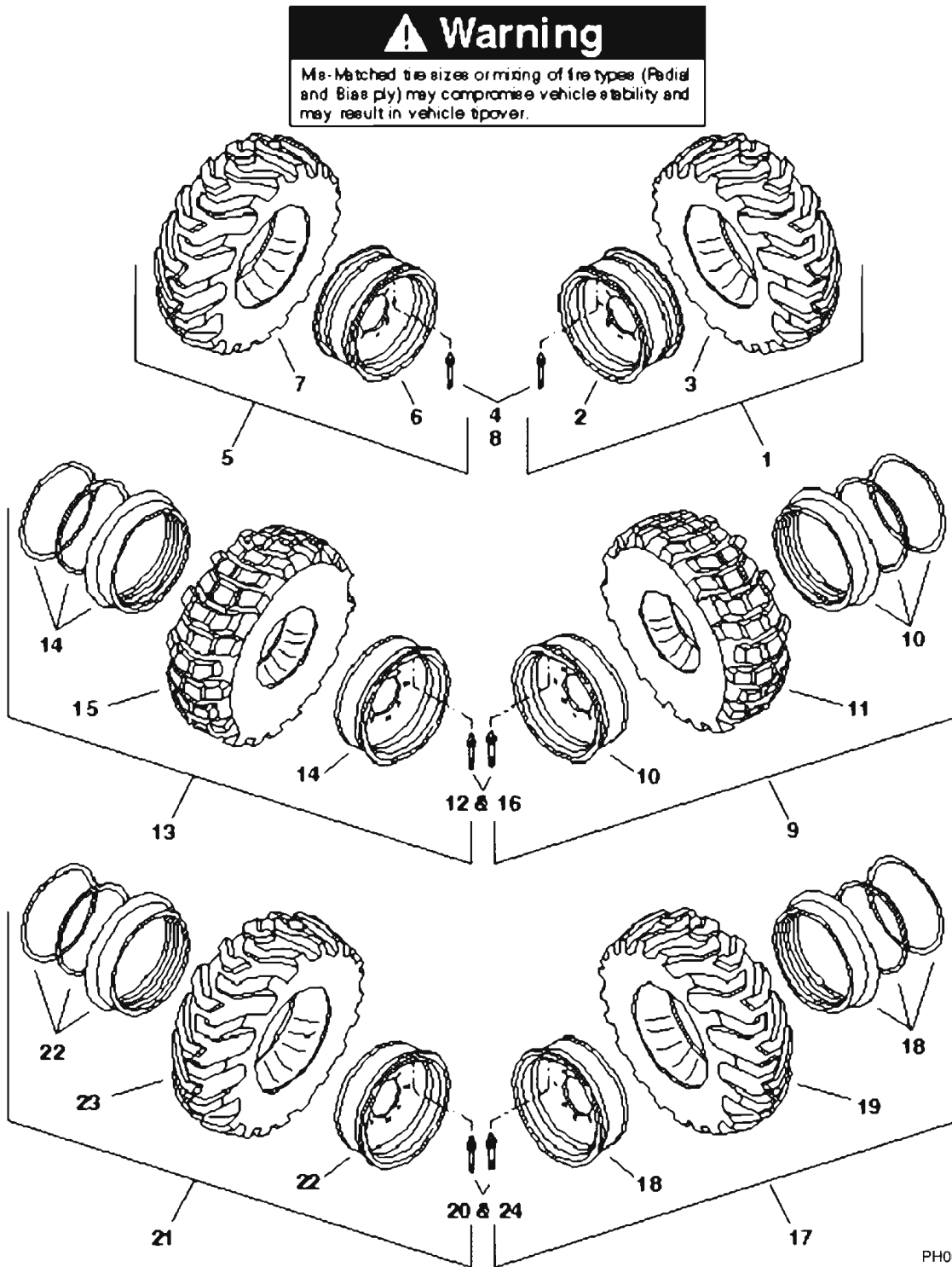

SECTION 3 - DRIVE TRAIN

FIGURE 3-38. WHEELS AND TIRES - 10042/10054

ITEM	PART NUMBER	QTY	DESCRIPTION	REV
1	7099532	2	Tire and Wheel Ass'y, Right Side - 17.5 x 25, 12 Ply (Includes Items 2 thru 4)	
2	7098733	1	Wheel, 1325LR x 1.5 Offset	
3	8780037	1	Tire, 17.5 x 25, 12 Ply	
4	8786514	1	Stem, Valve	
5	7099522	2	Tire and Wheel Ass'y, Left Side - 17.5 x 25, 12 Ply (Includes Items 6 thru 8)	
6	7098733	1	Wheel, 1325LR x 1.5 Offset	
7	8780037	1	Tire, 17.5 x 25, 12 Ply	
8	8786514	1	Stem, Valve	
9	7099702	2	Tire and Wheel Ass'y, Right Side - 17.5 R25, 2 Star (Includes Items 10 thru 12)	
10	7110333	1	Wheel, 14.00 - 25	
11	8780035	1	Tire, 17.5 R25, 2 Star, Radial	
12	8786559	1	Stem, Valve	
13	7099692	2	Tire and Wheel Ass'y, Left Side - 17.5 R25, 2 Star (Includes Items 14 thru 16)	
14	7110333	1	Wheel, 14.00 - 25	
15	8780035	1	Tire, 17.5 R25, 2 Star, Radial	
16	8786559	1	Stem, Valve	
17	7110352	2	Tire and Wheel Ass'y, Right Side - 17.5 x 25, 12 Ply (Includes Items 18 thru 20)	
18	7110333	1	Wheel, 14.00 - 25	
19	8780037	1	Tire, 17.5 x 25, 12 Ply	
20	8786559	1	Stem, Valve	
21	7110342	2	Tire and Wheel Ass'y, Left Side - 17.5 x 25, 12 Ply (Includes Items 22 thru 24)	
22	7110333	1	Wheel, 14.00 - 25	
23	8780037	1	Tire, 17.5 x 25, 12 Ply	
24	8786559	1	Stem, Valve	

SECTION 4 - POWER PLANT

SECTION 4 - POWER PLANT

FIGURE 4-1. ENGINE, RADIATOR AND OIL COOLER MOUNTING (Prior to SN 0119)

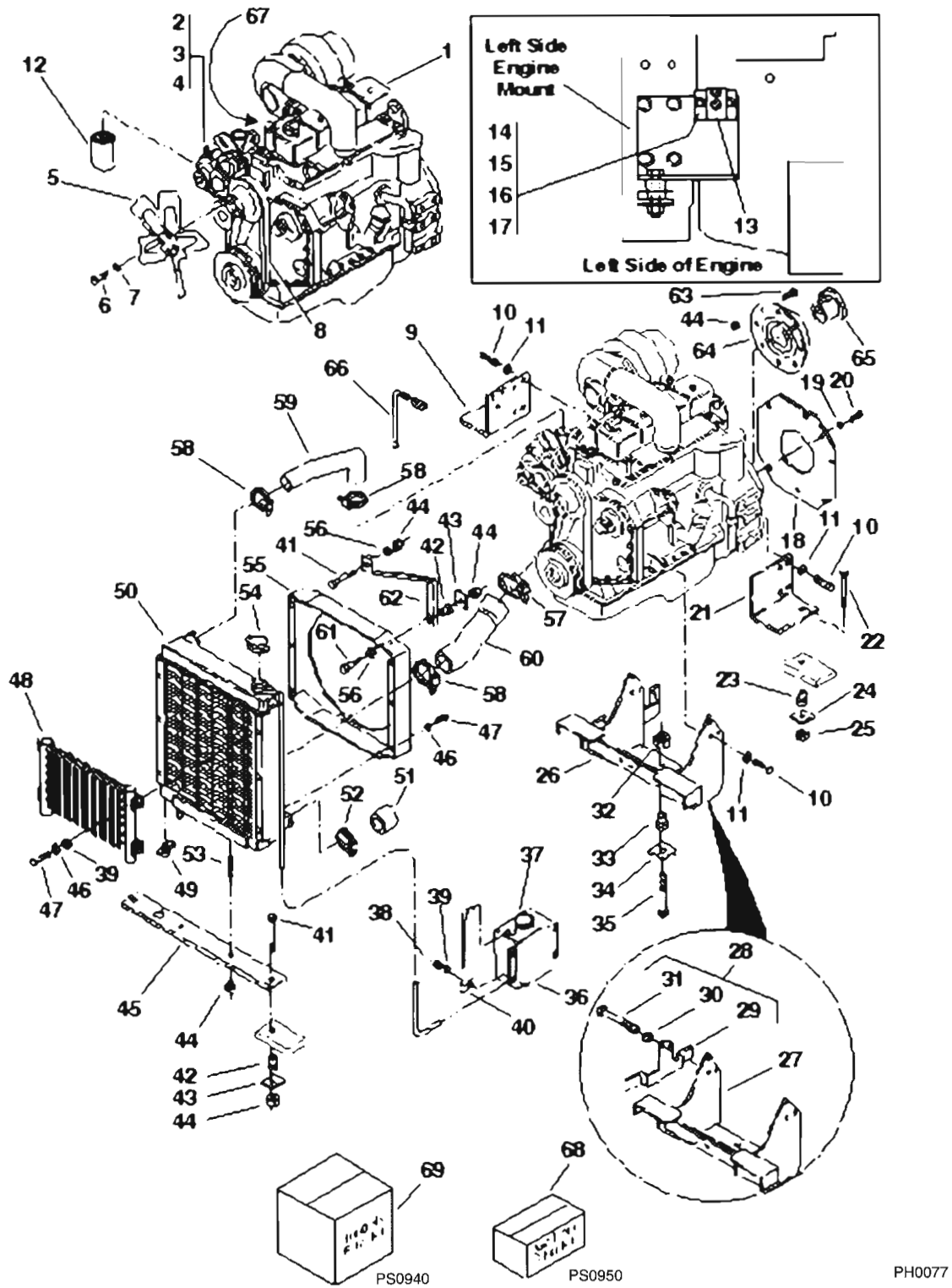

PH0077

SECTION 4 - POWER PLANT

FIGURE 4-1. ENGINE, RADIATOR AND OIL COOLER MOUNTING (Prior to SN 0119)

ITEM	PART NUMBER	QTY	DESCRIPTION	REV
1	7096692	1	Engine, Cummins 4BT 3.9 Turbo	
1	8262131	1	Engine, Cummins 4BTA 3.9 After Cooled Turbo	
2	8270221	1	Alternator, Bosch	
3	8270220	1	Fan, Alternator	
4	8033342	1	Pulley, Alternator	
5	8272009	1	Fan, Puller 17in	
6	8310028	4	HHCS, M8 x 70mm	
7	8307222	4	Washer, Flat M8	
8	8080613	1	Belt, Engine Fan	
9	7095272	1	Mount, Engine Left Side	
10	8303790	14	HHCS, M12 x 30mm	
11	8307025	14	Washer, Lock M12	
12	8320262	1	Element, Engine Oil Filter (Also included in Filter Kits 68 & 69)	
13	8277162	1	Solenoid, Relay for Starter, Sealed	
14	8303742	2	FLHDCS, 1/4-20 x 1in	
15	8310002	2	Washer, Lock 1/4in External Teeth	
16	8307109	2	Washer, Flat 1/4in	
17	8305624	2	Nut, Hex Lock Elastic 1/4-20	
18	7054632	1	Cover, Flywheel	
19	8307023	4	Washer, Lock M10	
20	8303784	4	HHCS, M10 x 20mm	
21	7095282	1	Mount, Engine Right Side	
22	8303702	2	HHCS, 1/2-13 x 3in	
23	8278012	2	Mount, Vibration	
24	7095831	2	Washer, Rebound	
25	8305644	2	Nut, Hex Lock Elastic 1/2-13	
26	7133022	1	Kit, Engine Mount (Includes Items 27 & 28)	
27	7127003	1	Mount, Engine	
28	7132912	1	Kit, Muffler Strap (Includes Items 29 thru 31)	
29	7127013	1	Bracket, Muffler	
30	8307025	2	Washer, Lock M12	
31	8303519	2	HHCS, M12 x 35mm	
32	8310067	1	Nut, Hex Lock Elastic 3/4-10	
33	8278007	1	Mount, Vibration	
34	7054351	1	Washer, Rebound	
35	8303724	1	HHCS, 3/4-10 x 3-1/2in	
36	7085422	1	Tank, Radiator Overflow (Includes Item 37)	
37	8866341	1	Cap w/ Tether	
38	8305626	4	Nut, Hex Lock Elastic 5/16-18	
39	8307106	8	Washer, Flat 5/16in	
40	8406101	1	Support, Hose 5/8in	
41	8303106	3	HHCS, 3/8-16 x 2-1/2in	
42	8278008	3	Mount, Vibration	
43	7057141	3	Washer, Rebound	
44	8305645	14	Nut, Hex Lock Elastic 3/8-16	
45	7094592	1	Bar, Radiator Mount	
46	8307004	10	Washer, Lock 5/16in	
47	8303744	10	HHCS, 5/16-18 x 1/2in	
48	2712993	1	Oil Cooler	
49	8904001	1	Cock, Drain 1/4in	

SECTION 4 - POWER PLANT

ITEM	PART NUMBER	QTY	DESCRIPTION	REV
50	5724284	1	Radiator (Includes Items 51 thru 54)	
51	8403224	1	Cap, Connection	
52	8405104	1	Clamp, Hose 2-1/4in	
53	8180308	2	Stud, Radiator Mount	
54	8180307	1	Cap, Radiator	
55	7099943	1	Shroud, Radiator	
56	8307110	2	Washer, Flat 3/8in	
57	8405203	1	Clamp, Hose 3in	
58	8405104	3	Clamp, Hose 2-1/4in	
59	7093783	1	Hose, Upper Radiator	
60	7093772	1	Hose, Lower Radiator	
61	8303622	1	HHCS, 3/8-16 x 2in	
62	7099912	1	Support, Upper Radiator	
63	8303679	8	HHCS, 3/8-16 x 1-3/4in	
64	7150523	1	Kit, Torsion Dampener Coupling (Includes Coupler, Shaft, Hardware and Instructions)	
65	8140309	1	Bushing, Split Tapered	
66	8277161	1	Heater, Coolant	
66	7088352	1	Freeze Plug	
67	8033340	1	Starter, 12V (Includes Solenoid)	
68	7138291	1	Kit, 250 Hour Filter (Includes 4 Filters; Engine Oil Filter & 3 Fuel Filters)	
69	7138301	1	Kit, 1000 Hour Filter (Includes 7 Filters; Engine Oil Filter, 3 Fuel Filters, Primary Air Filter, Transmission Oil Filter and Hydraulic Oil Filter)	

SECTION 4 - POWER PLANT

FIGURE 4-2. ENGINE, RADIATOR AND OIL COOLER MOUNTING (SN 0119 through 1598)

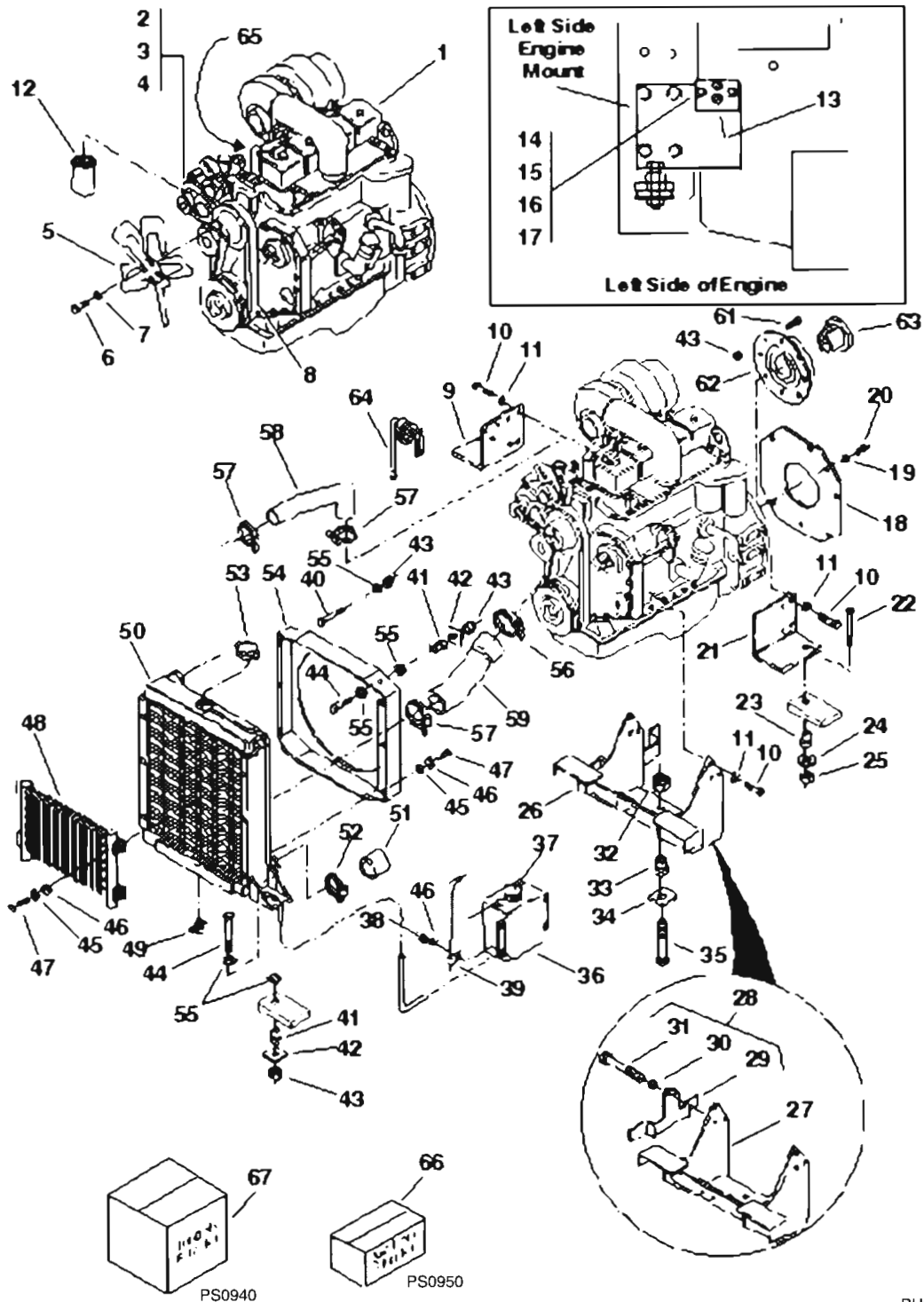

PH0076

SECTION 4 - POWER PLANT

FIGURE 4-2. ENGINE, RADIATOR AND OIL COOLER MOUNTING (SN 0119 through 1598)

ITEM	PART NUMBER	QTY	DESCRIPTION	REV
1	8262137	1	Engine, Cummins 4BT 3.9 Turbo	
1	8262138	1	Engine, Cummins 4BTA 3.9 After Cooled Turbo	
2	8270221	1	Alternator, Bosch	
3	8270220	1	Fan, Alternator	
4	8033342	1	Pulley, Alternator	
5	8272009	1	Fan, Puller 17in	
6	8310028	4	HHCS, M8 x 70mm	
7	8307222	4	Washer, Flat M8	
8	8080613	1	Belt, Engine Fan	
9	7095272	1	Mount, Engine Left Side	
10	8303790	14	HHCS, M12 x 30mm	
11	8307025	14	Washer, Lock M12	
12	8320262	1	Element, Engine Oil Filter (Also included in Filter Kits 66 & 67)	
13	8277162	1	Solenoid, Relay for Starter	
14	8303742	2	FLHDCS, 1/4-20 x 1in	
15	8310002	2	Washer, Lock 1/4in External Teeth	
16	8307109	5	Washer, Flat 1/4in	
17	8305624	2	Nut, Hex Lock Elastic 1/4-20	
18	7054632	1	Cover, Flywheel	
19	8307023	4	Washer, Lock M10	
20	8303784	4	HHCS, M10 x 20mm	
21	7095282	1	Mount, Engine Right Side	
22	8303702	2	HHCS, 1/2-13 x 3in	
23	8278012	2	Mount, Vibration	
24	7095831	2	Washer, Rebound	
25	8305644	2	Nut, Hex Lock Elastic 1/2-13	
26	7133022	1	Kit, Engine Mount (Includes Items 27 & 28)	
27	7127003	1	Mount, Engine	
28	7132912	1	Kit, Muffler Strap (Includes Items 29 thru 31)	
29	7127013	1	Bracket, Muffler	
30	8307025	2	Washer, Lock M12	
31	8303519	2	HHCS, M12 x 35mm	
32	8310067	1	Nut, Hex Lock Elastic 3/4-10	
33	8278007	1	Mount, Vibration	
34	7054351	1	Washer, Rebound	
35	8303724	1	HHCS, 3/4-10 x 3-1/2in	
36	7085422	1	Tank, Radiator Overflow (Includes Item 37)	
37	8866341	1	Cap w/Tether	
38	8305626	4	Nut, Hex Lock Elastic 5/16-18	
39	8406101	1	Support, Hose 5/8in	
40	8303106	1	HHCS, 3/8-16 x 2-1/2in	
41	8278008	3	Mount, Vibration	
42	7057141	3	Washer, Rebound	
43	8305645	12	Nut, Hex Lock Elastic 3/8-16	
44	8303622	3	HHCS, 3/8-16 x 2in	
45	8307004	10	Washer, Lock 5/16in	
46	8307203	10	Washer, Flat 0.31	
47	8303697	10	HHCS, 0.31 x 0.75in	
48	2712993	1	Oil Cooler	
49	8904001	1	Cock, Drain 1/4in	

SECTION 4 - POWER PLANT

ITEM	PART NUMBER	QTY	DESCRIPTION	REV
50	7127034	1	Radiator (Includes Items 51 thru 53)	
51	8403224	1	Cap, Connection	
52	8405104	1	Clamp, Hose 2-1/4in	
53	8180307	1	Cap, Radiator	
54	7127043	1	Shroud, Radiator	
55	8307204	7	Washer, Flat 3/8in Heavy	
56	8405203	1	Clamp, Hose 3in	
57	8405104	3	Clamp, Hose 2-1/4in	
58	7093783	1	Hose, Upper Radiator	
59	7093772	1	Hose, Lower Radiator	
60	7099912	1	Support, Upper Radiator	
61	8303679	8	HHCS, 3/8-16 x 1-3/4in	
62	7150523	1	Kit, Torsion Dampener Coupling (Includes Coupler, Shaft, Hardware and Instructions)	
63	8140309	1	Bushing, Split Tapered	
64	8277161	1	Heater, Coolant	
64	7088352	1	Freeze Plug	
65	8033340	1	Starter, 12V (Includes Solenoid)	
66	7138291	1	Kit, 250 Hour Filter (Includes 4 Filters; Engine Oil Filter & 3 Fuel Filters)	
67	7138301	1	Kit, 1000 Hour Filter (Includes 7 Filters; Engine Oil Filter, 3 Fuel Filters, Primary Air Filter, Transmission Oil Filter and Hydraulic Oil Filter)	

SECTION 4 - POWER PLANT

FIGURE 4-3. ENGINE, RADIATOR AND OIL COOLER MOUNTING (EPA) (SN 1599 through 13197)

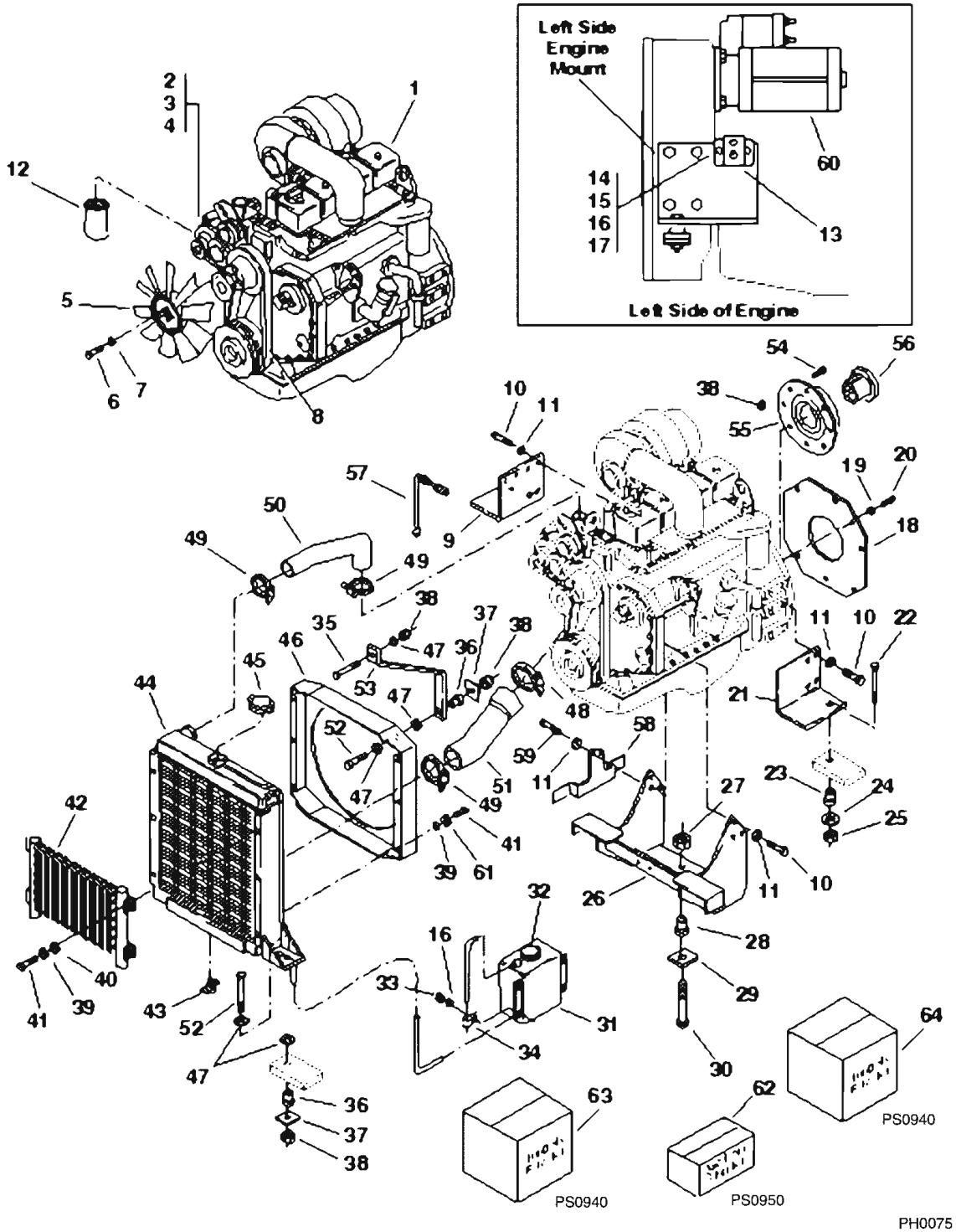

SECTION 4 - POWER PLANT

FIGURE 4-3. ENGINE, RADIATOR AND OIL COOLER MOUNTING (EPA) (SN 1599 through 13197)

ITEM	PART NUMBER	QTY	DESCRIPTION	REV
1	8262142	1	Engine, Cummins 4BT 3.9 Turbo (8042)	
1	8262143	1	Engine, Cummins 4BTA 3.9 After Cooled Turbo (10042 & 10054)	
2	8270221	1	Alternator, Bosch	
3	8270220	1	Fan, Alternator	
4	8033342	1	Pulley, Alternator	
5	8272017	1	Fan	
6	8303550	4	HHCS, M8 x 60mm	
7	8307222	4	Washer, Flat M8	
8	8080613	1	Belt, Engine Fan	
9	7095272	1	Mount, Engine Left Side	
10	8303790	14	HHCS, M12 x 30mm	
11	8307025	14	Washer, Lock M12	
12	8320262	1	Element, Engine Oil Filter (Also included in Filter Kits 62, 63 & 64)	
13	8277162	1	Solenoid, Relay for Starter	
14	8303742	2	FLHDCS, 1/4-20 x 1in	
15	8310002	2	Washer, Lock 1/4in External Teeth	
16	8307109	4	Washer, Flat 1/4in	
17	8305624	2	Nut, Hex Lock Elastic 1/4-20	
18	7054632	1	Cover, Flywheel	
19	8307023	4	Washer, Lock M10	
20	8303784	4	HHCS, M10 x 20mm	
21	7095282	1	Mount, Engine Right Side	
22	8303702	2	HHCS, 1/2-13 x 3in	
23	8278012	2	Mount, Vibration	
24	7095831	2	Washer, Rebound	
25	8305644	2	Nut, Hex Lock Elastic 1/2-13	
26	7127003	1	Mount, Engine	
27	8310067	1	Nut, Hex Lock Elastic 3/4-10	
28	8278007	1	Mount, Vibration	
29	7054351	1	Washer, Rebound	
30	8303724	1	HHCS, 3/4-10 x 3-1/2in	
31	7085422	1	Tank, Radiator Overflow (Includes Item 32)	
32	8866341	1	Cap w/Tether	
33	8305626	4	Nut, Hex Lock Elastic 5/16-18	
34	8406101	1	Support, Hose 5/8in	
35	8303106	3	HHCS, 3/8-16 x 2-1/2in	
36	8278008	3	Mount, Vibration	
37	7057141	3	Washer, Rebound	
38	8305645	14	Nut, Hex Lock Elastic 3/8-16	
39	8307004	10	Washer, Lock 0.31	
40	8307106	6	Washer, Flat 0.31	
41	8303697	10	HHCS, 0.31 x 0.75in	
42	2712993	1	Oil Cooler (SN 1599 through 9908)	
42	2713054	1	Oil Cooler (SN 9909 to Present)	
43	8904001	1	Cock, Drain 1/4in	
44	7127034	1	Radiator (Includes Item 45)	
45	8180307	1	Cap, Radiator	
46	7127043	1	Shroud, Radiator	
47	8307110	5	Washer, Flat 3/8in	
48	8405203	1	Clamp, Hose 3in	

SECTION 4 - POWER PLANT

ITEM	PART NUMBER	QTY	DESCRIPTION	REV
49	8405104	3	Clamp, Hose 2-1/4in	
50	7093783	1	Hose, Upper Radiator	
51	7093772	1	Hose, Lower Radiator	
52	8303622	3	HHCS, 3/8-16 x 2in	
53	7099912	1	Support, Upper Radiator	
54	8303679	8	HHCS, 3/8-16 x 1-3/4in	
55	7150523	1	Kit, Torsion Dampener Coupling (Includes Coupler, Shaft, Hardware and Instructions) (SN 1599 through 9908)	
55	7137643	1	Torsion Dampener Coupling (SN 9909 to Present)	
56	8140309	1	Bushing, Split Tapered	
57	8277161	1	Heater, Coolant	
58	7127013	1	Bracket, Muffler	
59	8303519	2	HHCS, M12 x 35mm	
60	8033340	1	Starter, 12V (Includes Solenoid)	
61	8307203	6	Washer, Flat	
62	7138290	1	Kit, 250 Hour Filter (Includes 3 Filters; Engine Oil Filter and Both Fuel Filters)	
63	7138297	1	Kit, 1000 Hour Filter (Includes 6 Filters; Engine Oil Filter, Both Fuel Filters, Primary Air Filter, Transmission Oil Filter and Hydraulic Oil Filter) (SN 1599 through 9908)	
64	7138848	1	Kit, 1000 Hour Filter (Includes 6 Filters; Engine Oil Filter, Both Fuel Filters, Primary Air Filter, Transmission Oil Filter and Hydraulic Oil Filter) (SN 9909 to Present)	

SECTION 4 - POWER PLANT

FIGURE 4-4. TORSION COUPLER (SN 9909 through 13197)

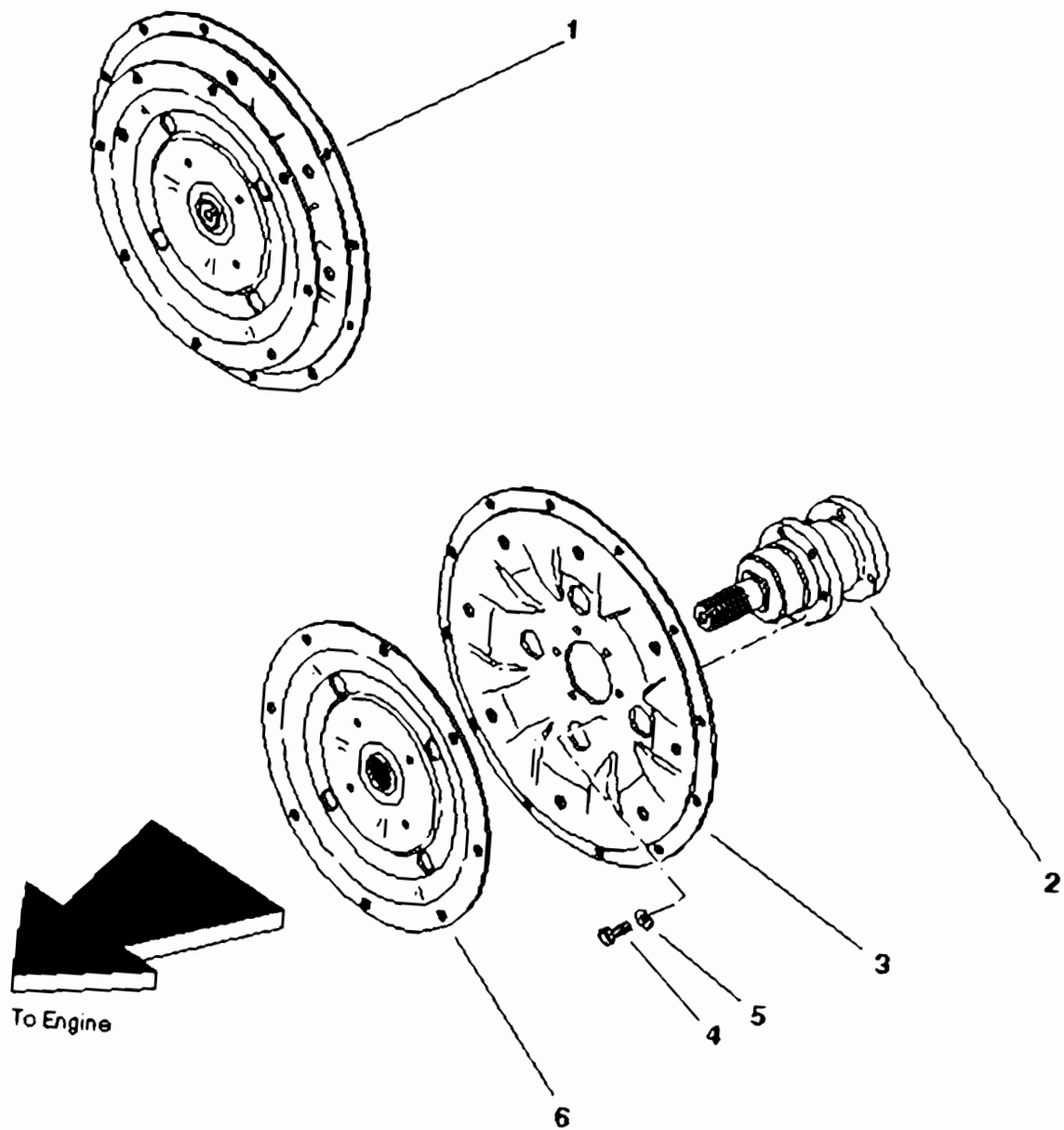

PH1230

SECTION 4 - POWER PLANT

FIGURE 4-4. TORSION COUPLER (SN 9909 through 13197)

ITEM	PART NUMBER	QTY	DESCRIPTION	REV
1	7137643	1	Coupling Assembly, Torsion (Includes Items 2 thru 6)	
2	8035555	1	Assembly, Shaft and Bearing	
3	8035556	1	Housing, Protective	
4	8035557	6	Bolt, Hex Hd M10 x 25mm	
5	8035558	6	Washer, Flat M10	
6	8035559	1	Element, Torsion Coupling	

SECTION 4 - POWER PLANT

FIGURE 4-5. EXHAUST SYSTEM

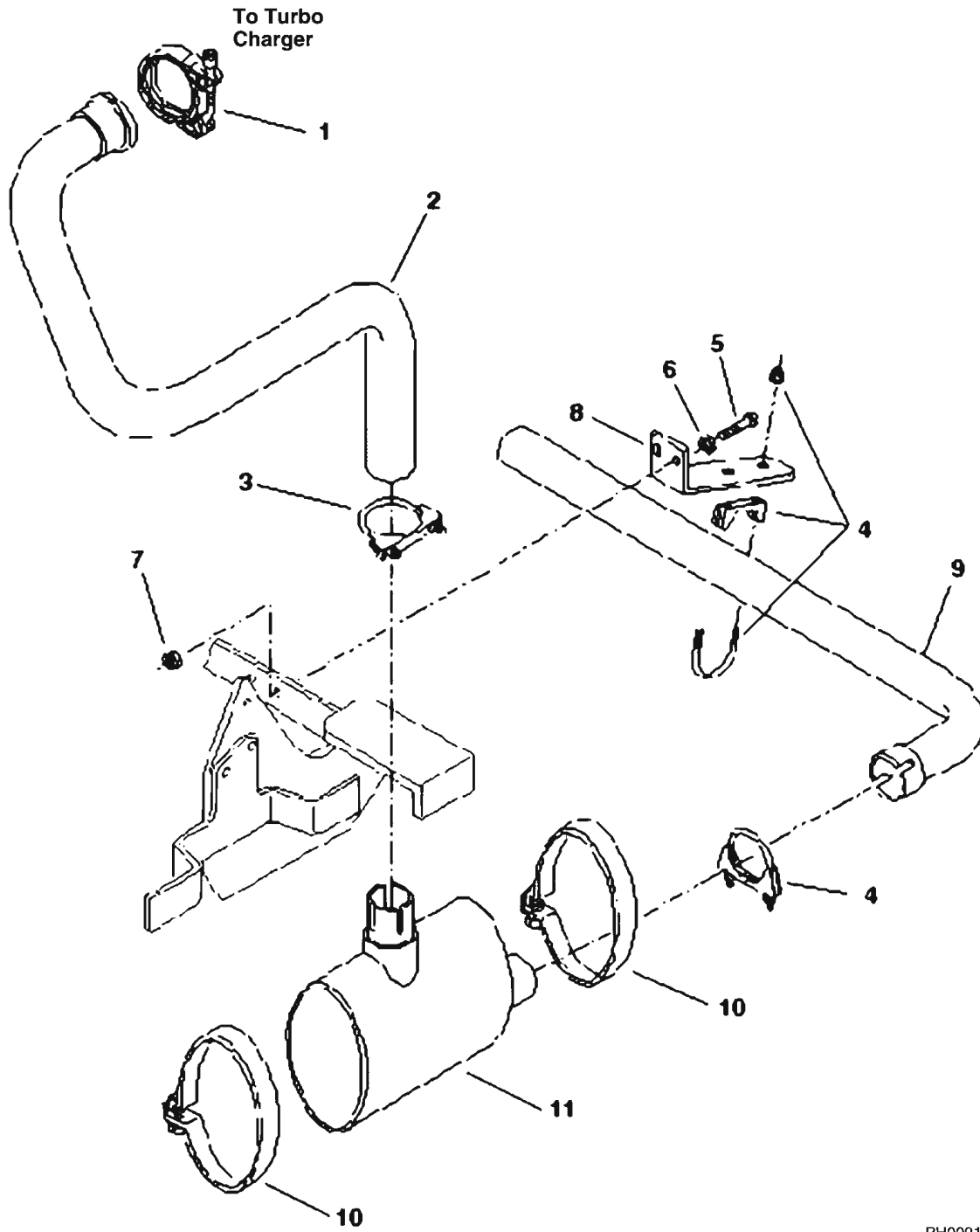

PH0091

SECTION 4 - POWER PLANT

FIGURE 4-5. EXHAUST SYSTEM

ITEM	PART NUMBER	QTY	DESCRIPTION	REV
1	8275240	1	Clamp, V-Band	
2	7126953	1	Pipe, Exhaust (SN 1599 to Present)	
2	7088283	1	Pipe, Exhaust (Prior to SN 1599)	
3	8275247	1	Clamp, Muffler 3.00 (SN 1599 to Present)	
3	8275212	1	Clamp, Muffler 2.50in (Prior to SN 1599)	
4	8275248	2	Clamp, Muffler 2.75 (SN 1599 to Present)	
4	8275212	2	Clamp, Muffler 2.50in (Prior to SN 1599)	
5	8303621	2	HHCS, 3/8-16 x 1-1/2in	
6	8307204	2	Washer, Flat 3/8in Heavy	
7	8305645	2	Nut, Hex Lock Elastic 3/8-16	
8	7127022	1	Support, Exhaust Pipe (SN 1599 to Present)	
8	7110022	1	Support, Exhaust Pipe (Prior to SN 1599)	
9	7126962	1	Pipe, Tail (SN 1599 to Present)	
9	7086742	1	Pipe, Tail (Prior to SN 1599)	
10	7126992	2	Clamp, Band (SN 1599 to Present)	
10	7097452	2	Clamp, Band (Prior to SN 1599)	
11	7126922	1	Muffler (SN 1599 to Present)	
11	7079162	1	Muffler (Prior to SN 1599)	

SECTION 4 - POWER PLANT

FIGURE 4-6. AIR CLEANER

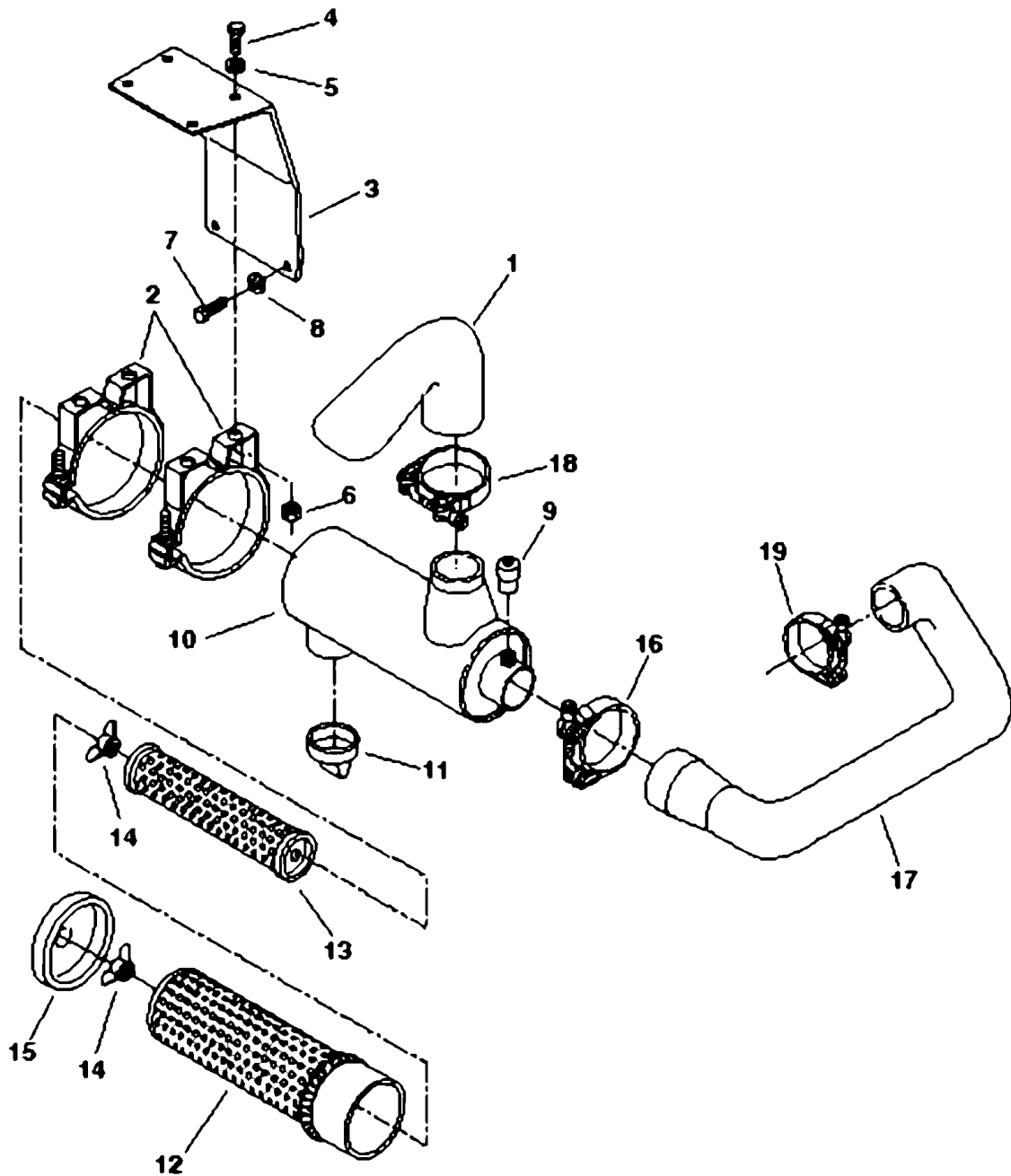

PH0081

SECTION 4 - POWER PLANT

FIGURE 4-6. AIR CLEANER

ITEM	PART NUMBER	QTY	DESCRIPTION	REV
1	7097323	1	Scoop, Air Intake	
2	8273240	2	Band, Air Cleaner Mounting	
3	7095302	1	Bracket, Air Cleaner Mounting	
4	8303697	4	HHCS, 0.31 x 0.75in	
5	8307203	4	Washer, Flat 5/16in	
6	8305626	4	Nut, Hex Lock Elastic 5/16in	
7	8303618	2	HHCS, M12 x 25mm	
8	8307025	2	Washer, Lock M12	
9	8273241	1	Indicator, 25in Service	
10	8273013	1	Air Cleaner Assembly (Includes Items 11 thru 15)	
11	8032764	1	Valve, Vacuator	
12	8273237	1	Element, Primary	
13	8273238	1	Element, Safety	
14	8273272	2	Nut, Assembly	
15	8032762	1	Cover, End	
16	8405307	1	Clamp, T-Bolt 3-13/16in I.D.	
17	7095393	1	Hose, Air Intake	
18	8405404	1	Clamp, T-Bolt Band 4.38in I.D.	
19	8405305	1	Clamp, T-Bolt Band 3.38in I.D.	

SECTION 4 - POWER PLANT

FIGURE 4-7. FUEL SYSTEM (Prior to SN 1599)

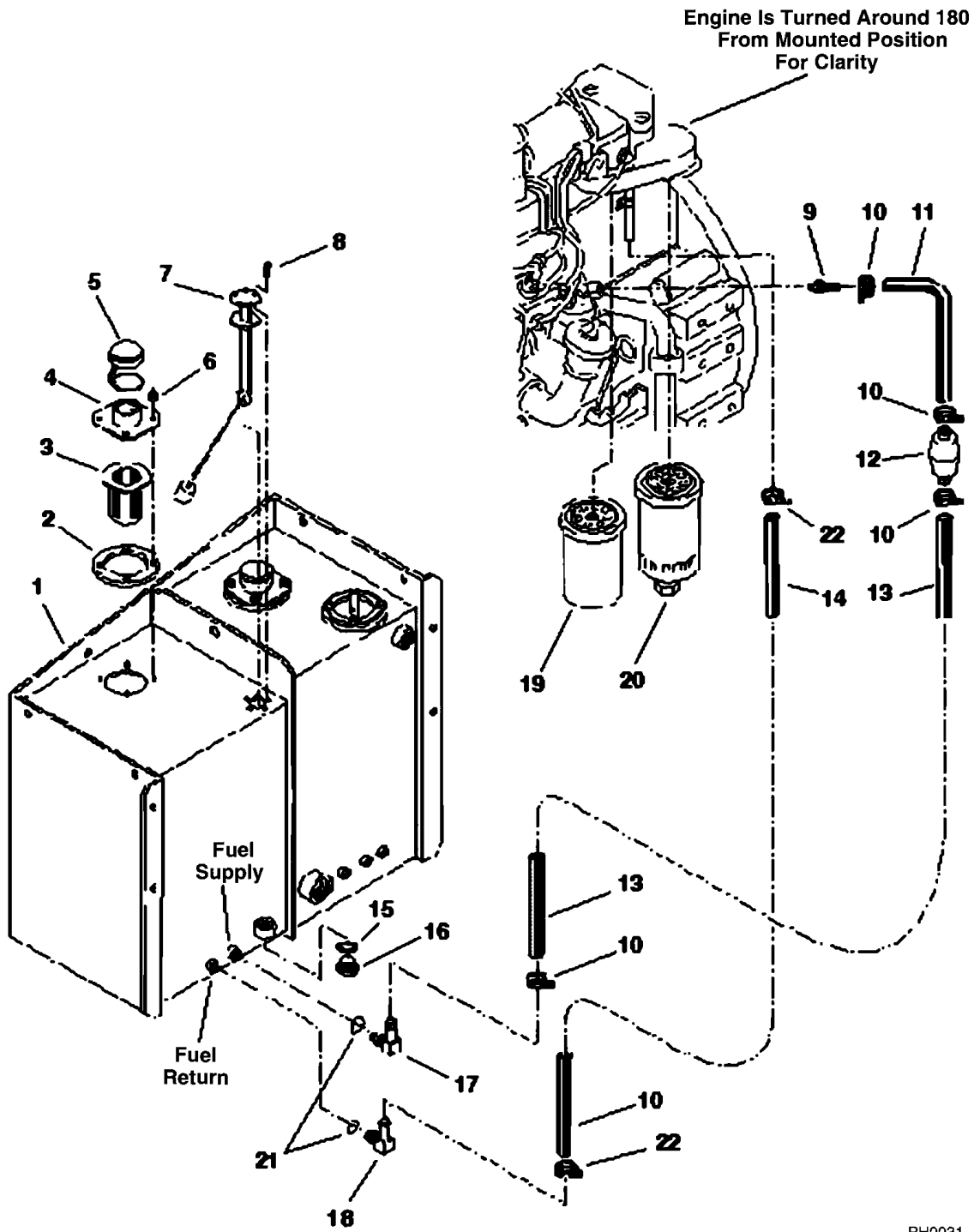

PH0031

SECTION 4 - POWER PLANT

FIGURE 4-7. FUEL SYSTEM (Prior to SN 1599)

ITEM	PART NUMBER	QTY	DESCRIPTION	REV
1	7136034	1	Tank, Fuel and Hydraulic	
2	7138209	1	Gasket	
3	NLA	1	Screen, Fillneck (For Service, Order P/N 8322022 & 7139076)	
4	7138714	1	Neck, Filler/Breather	
5	NLA	1	Cap, Fill w/Chain (For Service, Order P/N 8322022 & 7139076)	
6	8305626	4	Nut, Hex Lock Elastic 5/16-18	
7	7118222	1	Sender, Fuel Level	
8	8310163	5	THCS, #10 x 5/8in	
9	8430007	1	Hose Fitting, Long, Barbed, SAE 6-4P - hose I.D. x male NPT, Fits 3/8in Hose	
10	8410009	4	Clamp, Hose 1.06 Dia	
11	7127881	1	Hose, Fuel Supply .38 x 4in	
12	8274022	1	Strainer, Fuel	
13	7127871	1	Hose, Fuel Supply .38 x 100in	
14	7125421	1	Hose, Fuel Return .25 x 105in	
15	8640903	1	O-Ring	
16	8541435	1	Plug, Magnetic, Hex Hd, 1in str thd	
17	8430034	1	Hose Fitting, Elbow, 90, Beaded, SAE 6-6 - hose I.D. x male str thd o-ring	
18	8430035	1	Hose Fitting, Elbow, 90, Beaded, SAE 4-4 - hose I.D. x male str thd o-ring, Fits 1/4in Hose	
19	8320250	1	Element, Fuel Filter - Secondary	
20	8320253	1	Element, Fuel Filter - Primary	
21	8630012	2	O-Ring	
22	8405009	2	Clamp, Hose .62	

SECTION 4 - POWER PLANT

FIGURE 4-8. FUEL SYSTEM (EPA) (SN 1599 through 13197)

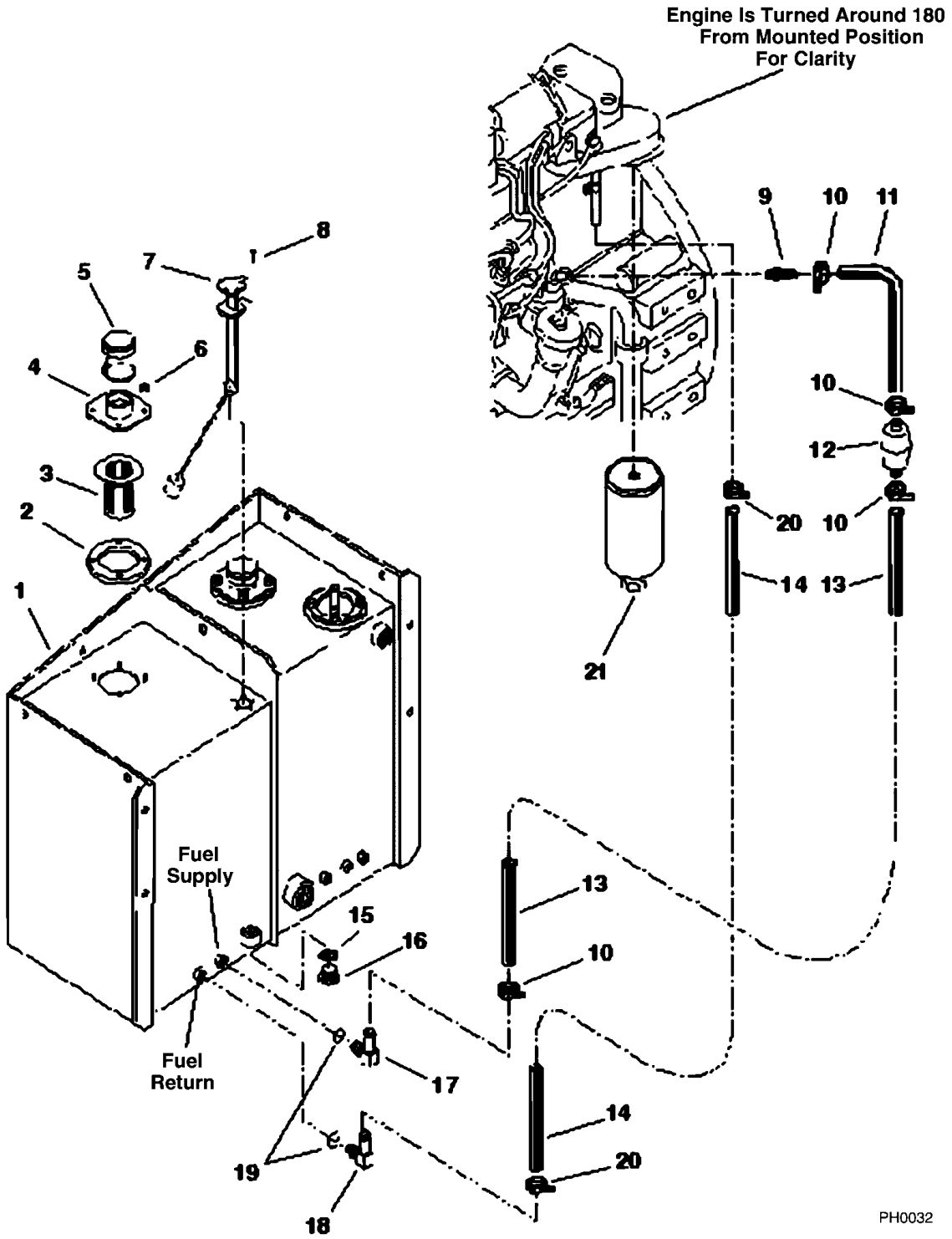

SECTION 4 - POWER PLANT

FIGURE 4-8. FUEL SYSTEM (EPA) (SN 1599 through 13197)

ITEM	PART NUMBER	QTY	DESCRIPTION	REV
1	7136034	1	Tank, Fuel and Hydraulic	
2	7138209	1	Gasket	
3	NLA	1	Screen, Fillneck (For Service, Order P/N 8322022 & 7139076)	
4	7138714	1	Neck, Filler/Breather	
5	NLA	1	Cap, Fill w/Chain (For Service, Order P/N 8322022 & 7139076) (Prior to SN 9500)	
5	8322029	1	Cap, Fill w/Chain (SN 9500 to Present)	
6	8305626	4	Nut, Hex Lock Elastic 5/16-18	
7	7118222	1	Sender, Fuel Level	
8	8310163	5	THCS, #10 x 5/8in	
9	8430007	1	Hose Fitting, Long, Barbed, SAE 6-4P - hose I.D. x male NPT, Fits 3/8in Hose	
10	8410009	4	Clamp, Hose 1.06 Dia	
11	7127881	1	Hose, Fuel Supply .38 x 4in	
12	8274022	1	Strainer, Fuel	
13	7127871	1	Hose, Fuel Supply .38 x 100in	
14	7127081	1	Hose, Fuel Return .31 x 123in	
15	8640903	1	O-Ring	
16	8541435	1	Plug, Magnetic, Hex Hd, 1in str thd	
17	8430034	1	Hose Fitting, Elbow, 90, Beaded, SAE 6-6 - hose I.D. x male str thd o-ring	
18	8430064	1	Hose Fitting, Elbow, 90, Beaded, SAE 5-6 - hose I.D. x male str thd o-ring, Fits 5/16in Hose	
19	8630012	2	O-Ring	
20	8405009	2	Clamp, Hose .62	
21	8320270	1	Element, Fuel Filter	

SECTION 5 - HYDRAULIC CIRCUITS

SECTION 5 - HYDRAULIC CIRCUITS

FIGURE 5-1. POWER STEERING CIRCUIT (Prior to SN 9909)

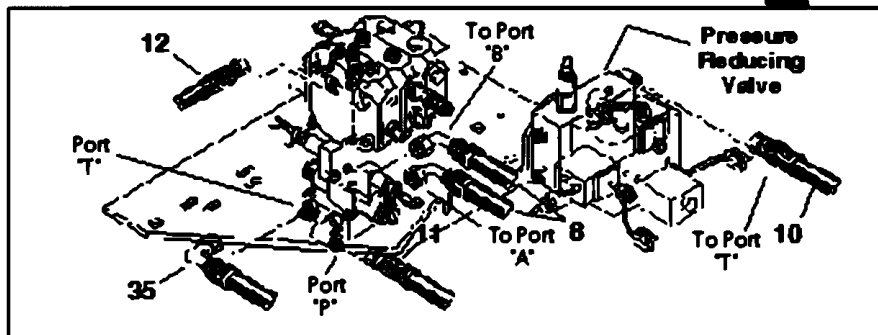
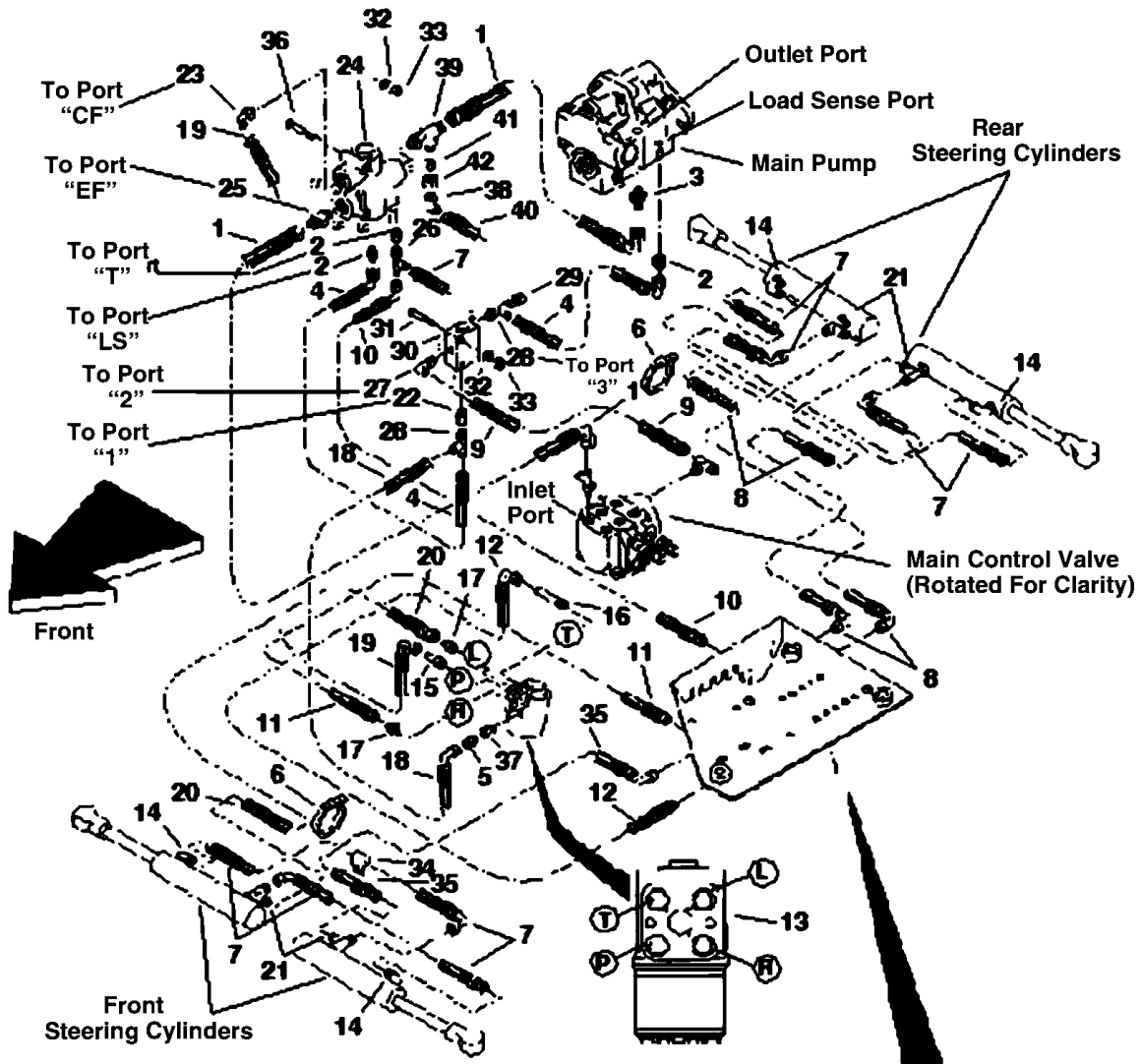

Underneath View of Valve Plate
See VALVE PLATE ASSEMBLY
for Breakdown

PH0142

SECTION 5 - HYDRAULIC CIRCUITS

FIGURE 5-1. POWER STEERING CIRCUIT (Prior to SN 9909)

ITEM	PART NUMBER	QTY	DESCRIPTION	REV
1	7150412	2	Hose, .75 I.D. x 18in Long	
2	8760134	3	Connector, Straight, SAE 6-4 - male JIC 37 x male str thd o-ring	
3	8760118	1	Connector, Straight, SAE 12-16 - male JIC 37 x male str thd o-ring	
4	2713432	2	Hose, .38 I.D. x 18in Long	
5	8760141	1	Connector, Male Tube End w/Outlet Check, 6-6	
6	8584007	2	Tie Wrap 5in	
7	2713242	5	Hose, .38 I.D. x 33in Long	
8	2713332	2	Hose, .38 I.D. x 96in Long	
9	2711992	1	Hose, .38 I.D. x 31in Long	
10	2712942	1	Hose, .38 I.D. x 50in Long	
11	2711972	1	Hose, .38 I.D. x 53in Long	
12	2712122	1	Hose, .50 I.D. x 62in Long	
13	8721029	1	Steering Unit	
14	8760311	4	Elbow, 90, SAE 6 - male JIC 37 x male str thd o-ring	
15	8760140	1	Connector, Male Tube End w/Inlet Check, 8-8	
16	8760143	1	Connector, Long, SAE 8 - male JIC 37 x male str thd o-ring	
17	8760110	2	Connector, Straight, SAE 6-8 - male JIC 37 x male str thd o-ring	
18	2712142	1	Hose, .38 I.D. x 89in Long	
19	2712112	1	Hose, .50 I.D. x 87in Long	
20	2710802	1	Hose, .38 I.D. x 105in Long	
21	8760449	4	Tee, Male Run, SAE 6 - male JIC 37 x male str thd o-ring	
22	8760460	1	Reducer, SAE 8-6 - male str thd o-ring x female internal o-ring boss	
23	8760303	1	Elbow, 90, SAE 8 - male JIC 37 x male str thd o-ring	
24	8904047	1	Priority Valve	
25	8760109	1	Connector, Straight, SAE 12 - male JIC 37 x male str thd o-ring	
26	8760501	1	Tee, Female Run, SAE 6 - male JIC 37 x female JIC 37, swivel	
27	8760313	1	Elbow, 90, SAE 6-8 - male JIC 37 x male str thd o-ring	
28	8760449	2	Tee, Male Run, SAE 6 - male JIC 37 x male str thd o-ring	
29	8760488	1	Cap, SAE 6 - JIC 37	
30	8902838	1	Valve, Shuttle	
31	8310158	2	Bolt, Carriage 5/16-18 x 2-1/4in	
32	8307004	4	Washer, Lock 5/16	
33	8305006	4	Nut, Hex 5/16-18	
34	8406105	1	Clamp	
35	2712012	1	Hose, .38 I.D. x 75in Long	
36	8310159	2	Bolt, Carriage 5/16-18 x 3-1/2in	
37	8770016	1	Reducer, SAE 4-6 - male str thd o-ring x female internal o-ring boss	
38	8765204	1	Elbow, 90, SAE 8 - male JIC 37 x female JIC 37, swivel	
39	8760474	1	Tee, Male Run, SAE 12 - male JIC 37 x male str thd o-ring	
40	6604882	1	Hose, .50 I.D. x 62in Long	
41	8760504	1	Reducer, Tube End, SAE 12-8 - JIC 37	
42	8760401	1	Nut, SAE 12 - JIC 37	

SECTION 5 - HYDRAULIC CIRCUITS

FIGURE 5-2. POWER STEERING CIRCUIT (SN 9909 through 13197)

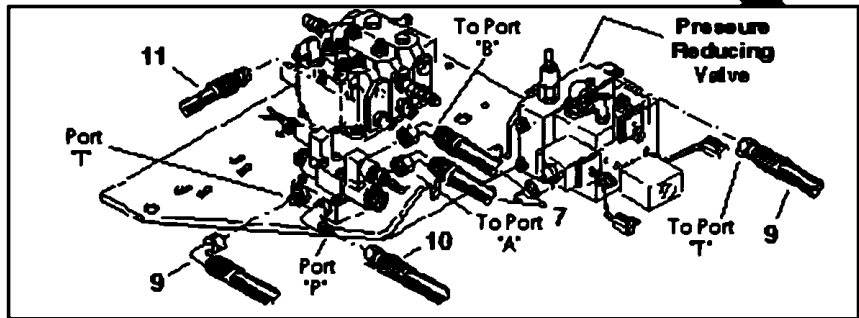
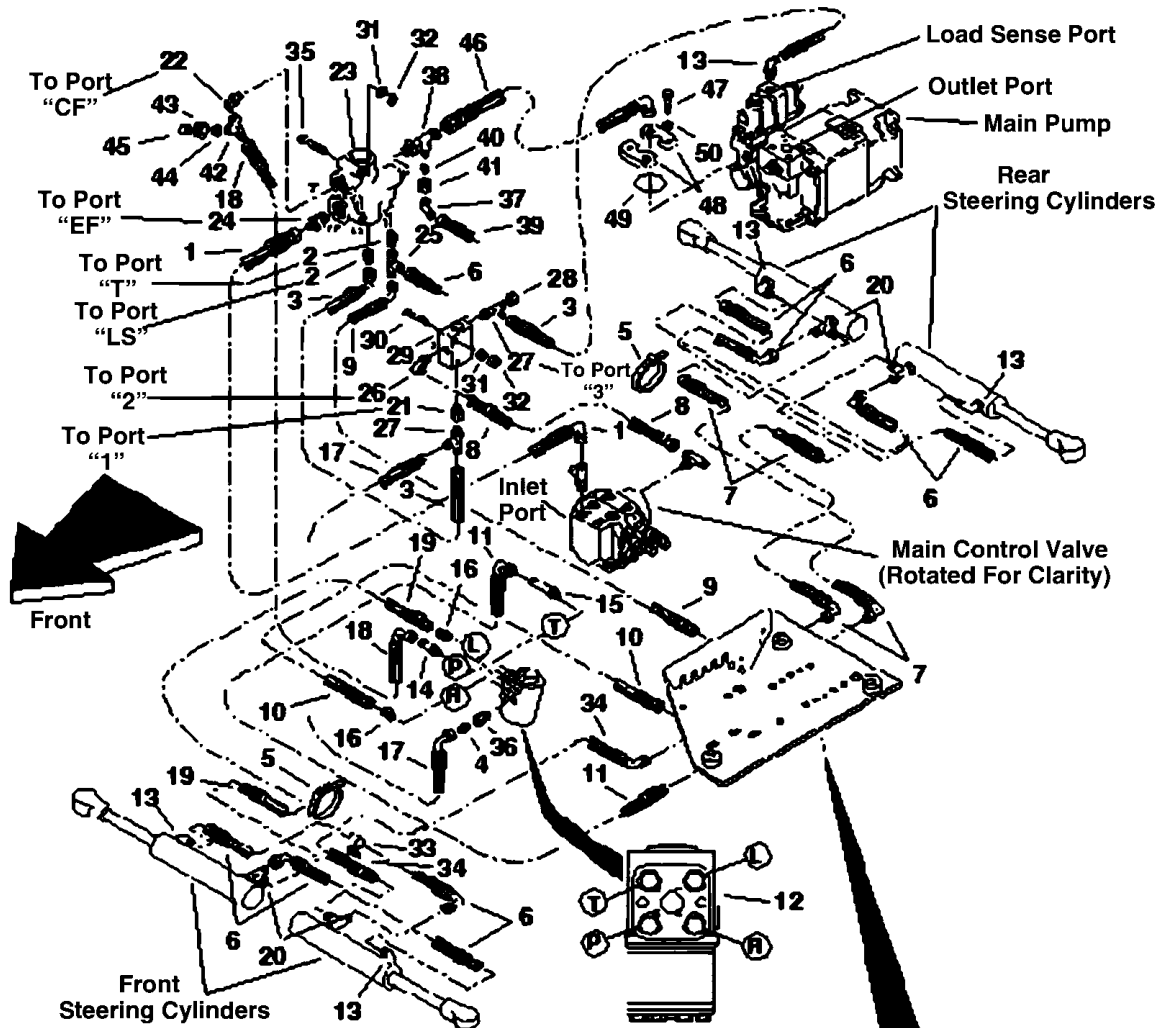

Underneath View of Valve Plate
See VALVE PLATE ASSEMBLY
for Breakdown

PH1360

SECTION 5 - HYDRAULIC CIRCUITS

FIGURE 5-2. POWER STEERING CIRCUIT (SN 9909 through 13197)

ITEM	PART NUMBER	QTY	DESCRIPTION	REV
1	7150412	1	Hose, .75 I.D. x 18in Long	
2	8760134	2	Connector, Straight, SAE 6-4 - male JIC 37 x male str thd o-ring	
3	2713432	2	Hose, .38 I.D. x 18in Long	
4	8760141	1	Connector, Male Tube End w/Outlet Check, 6-6	
5	8584007	2	Tie Wrap 5in	
6	2713242	5	Hose, .38 I.D. x 33in Long	
7	2713332	2	Hose, .38 I.D. x 96in Long	
8	2711992	1	Hose, .38 I.D. x 31in Long	
9	2712942	1	Hose, .38 I.D. x 50in Long	
10	2711972	1	Hose, .38 I.D. x 53in Long	
11	2712122	1	Hose, .50 I.D. x 62in Long	
12	8721029	1	Steering Unit	
13	8760311	5	Elbow, 90, SAE 6 - male JIC 37 x male str thd o-ring	
14	8760140	1	Connector, Male Tube End w/Inlet Check, 8-8	
15	8760143	1	Connector, Long, SAE 8 - male JIC 37 x male str thd o-ring	
16	8760110	2	Connector, Straight, SAE 6-8 - male JIC 37 x male str thd o-ring	
17	2712142	1	Hose, .38 I.D. x 89in Long	
18	2712112	1	Hose, .50 I.D. x 87in Long	
19	2710802	1	Hose, .38 I.D. x 105in Long	
20	8760449	4	Tee, Male Run, SAE 6 - male JIC 37 x male str thd o-ring	
21	8760460	1	Reducer, SAE 8-6 - male str thd o-ring x female internal o-ring boss	
22	8760307	1	Elbow, 45, SAE 8 - male JIC 37 x male str thd o-ring	
23	8904047	1	Priority Valve	
24	8760109	1	Connector, Straight, SAE 12 - male JIC 37 x male str thd o-ring	
25	8760501	1	Tee, Female Run, SAE 6 - male JIC 37 x female JIC 37, swivel	
26	8760313	1	Elbow, 90, SAE 6-8 - male JIC 37 x male str thd o-ring	
27	8760449	2	Tee, Male Run, SAE 6 - male JIC 37 x male str thd o-ring	
28	8760488	1	Cap, SAE 6 - JIC 37	
29	8902838	1	Valve, Shuttle	
30	8310158	2	Bolt, Carriage 5/16-18 x 2-1/4in	
31	8307004	4	Washer, Lock 5/16	
32	8305006	4	Nut, Hex 5/16-18	
33	8406105	1	Clamp	
34	2712012	1	Hose, .38 I.D. x 75in Long	
35	8310159	2	Bolt, Carriage 5/16-18 x 3-1/2in	
36	8770016	1	Reducer, SAE 4-6 - male str thd o-ring x female internal o-ring boss	
37	8765204	1	Elbow, 90, SAE 8 - male JIC 37 x female JIC 37, swivel	
38	8760474	1	Tee, Male Run, SAE 12 - male JIC 37 x male str thd o-ring	
39	6604882	1	Hose, .50 I.D. x 62in Long	
40	8760504	1	Reducer, Tube End, SAE 12-8 - JIC 37	
41	8760401	1	Nut, SAE 12 - JIC 37	
42	8760493	1	Tee, Female Run, SAE 8 - male JIC 37 x female JIC 37, swivel	
43	8760407	1	Nut, SAE 8 - JIC 37	
44	8430037	1	Nipple, Diagnostic	
45	8430032	1	Plug, Dust	
46	7150312	1	Hose, .75 I.D. x 25in Long	
47	8303675	4	Capscrew	
48	8530030	2	Flange Half, SAE 16	
49	8640123	1	O-Ring	
50	8307005	4	Washer, Lock 3/8	

SECTION 5 - HYDRAULIC CIRCUITS

FIGURE 5-3. CONTROL VALVES CIRCUIT (Prior to SN 9909)

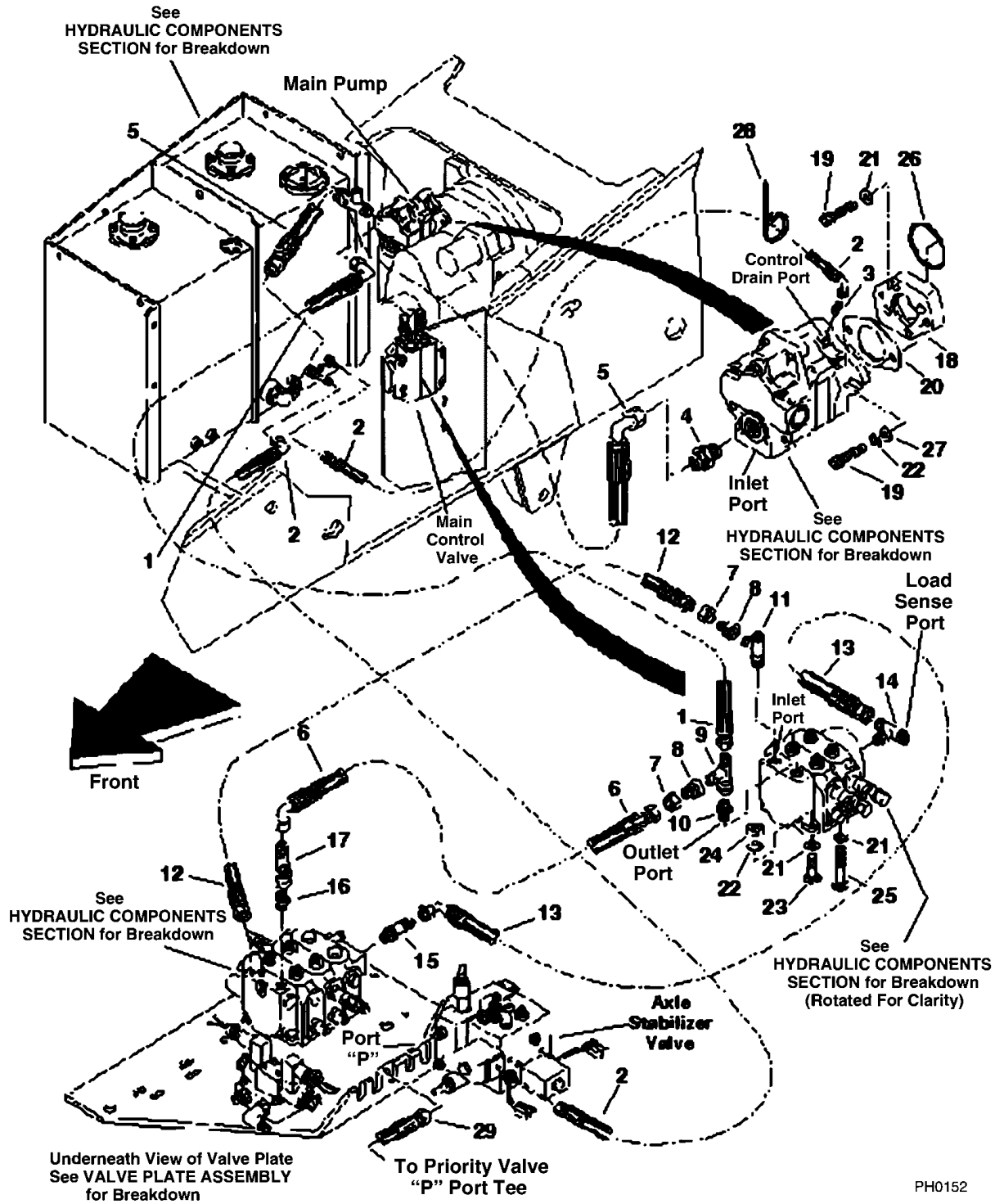

SECTION 5 - HYDRAULIC CIRCUITS

FIGURE 5-3. CONTROL VALVES CIRCUIT (Prior to SN 9909)

ITEM	PART NUMBER	QTY	DESCRIPTION	REV
1	2713292	1	Hose, .75 I.D. x 31in Long	
2	2712942	2	Hose, .38 I.D. x 50in Long	
3	8760117	1	Connector, Straight, SAE 6 - male JIC 37 x male str thd o-ring	
4	2220765	1	ADPT,ST S JIC/ORB 24 FG	
5	2713442	1	Hose, 1.50 I.D. x 29-1/2in Long	
6	2711872	1	Hose, .50 I.D. x 71in Long	
7	8760401	2	Nut, SAE 12 - JIC 37	
8	8760504	2	Reducer, Tube End, SAE 12-8 - JIC 37	
9	8760482	1	Tee, Female Run, SAE 12 - male JIC 37 x female JIC 37, swivel	
10	8760118	1	Connector, Straight, SAE 12-16 - male JIC 37 x male str thd o-ring	
11	8760474	1	Tee, Male Run, SAE 12 - male JIC 37 x male str thd o-ring	
12	6605202	1	Hose, .50 I.D. x 44-1/2in Long	
13	2711972	1	Hose, .38 I.D. x 53in Long	
14	8760457	1	Tee, Male Branch, SAE 6 - male JIC 37 x male str thd o-ring	
15	8760141	1	Connector, Male Tube End w/Outlet Check, 6-6	
16	8760107	1	Connector, Straight, SAE 8 - male JIC 37 x male str thd o-ring	
17	8760493	1	Tee, Female Run, SAE 8 - male JIC 37 x female JIC 37, swivel	
18	7121013	1	Spacer, Pump	
19	8304624	6	HHCS, 1/2-13 x 2in	
20	7099072	1	Gasket	
21	8307206	7	Washer, Flat 1/2in	
22	8307007	5	Washer, Lock 1/2in	
23	8310337	1	Bolt, Carriage 1/2-13 x 2-1/2in	
24	8305012	3	Nut, Hex 1/2-13	
25	8310178	2	Bolt, Carriage 1/2-13 x 4in	
26	8640405	1	O-Ring	
27	8307206	AR	Washer, Flat 1/2in	
28	8584007	1	Tie Wrap, 5in - Oil Cooler Hose Support	
29	6604882	1	Hose, .50 I.D. x 62in Long	

SECTION 5 - HYDRAULIC CIRCUITS

FIGURE 5-4. CONTROL VALVES CIRCUIT (SN 9909 through 13197)

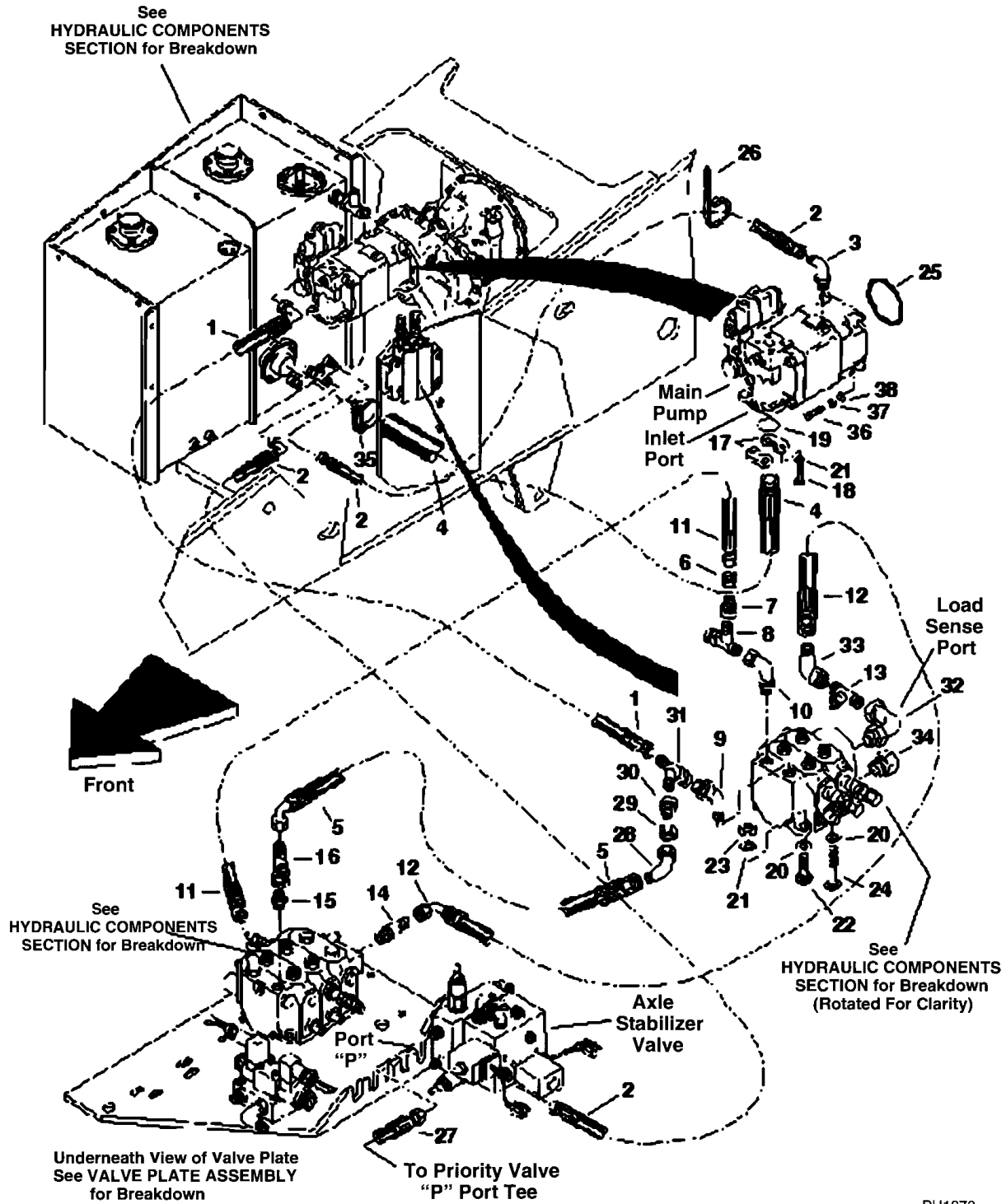

PH1370

SECTION 5 - HYDRAULIC CIRCUITS

FIGURE 5-4. CONTROL VALVES CIRCUIT (SN 9909 through 13197)

ITEM	PART NUMBER	QTY	DESCRIPTION	REV
1	7150492	1	Hose, 1 I.D. x 29in Long	
2	7150502	2	Hose, .50 I.D. x 40in Long	
3	8760308	1	Elbow, 90, SAE 8-10 - male JIC 37 x male str thd o-ring	
4	7150302	1	Hose, 2in I.D. x 29in Long	
5	2711872	1	Hose, .50 I.D. x 71in Long	
6	8760401	1	Nut, SAE 12 - JIC 37	
7	8760504	1	Reducer, Tube End, SAE 12-8 - JIC 37	
8	8760482	1	Tee, Female Run, SAE 12 - male JIC 37 x female JIC 37, swivel	
9	8760302	1	Elbow, 45, SAE 16 - male JIC 37 x male str thd o-ring	
10	8760317	1	Elbow, 45, SAE 12 - male JIC 37 x male str thd o-ring	
11	6604882	1	Hose, .50 I.D. x 62in Long	
12	2711972	1	Hose, .38 I.D. x 53in Long	
13	8760501	1	Tee, Female Run, SAE 6 - male JIC 37 x female JIC 37, swivel	
14	8760141	1	Connector, Male Tube End w/Outlet Check, 6-6	
15	8760107	1	Connector, Straight, SAE 8 - male JIC 37 x male str thd o-ring	
16	8760493	1	Tee, Female Run, SAE 8 - male JIC 37 x female JIC 37, swivel	
17	8546407	2	Flange	
18	8303626	4	Capscrew	
19	8640208	1	O-Ring	
20	8307206	4	Washer, Flat 1/2in	
21	8307007	7	Washer, Lock 1/2in	
22	8310337	1	Bolt, Carriage 1/2-13 x 2-1/2in	
23	8305012	3	Nut, Hex 1/2-13	
24	8310178	2	Bolt, Carriage 1/2-13 x 4in	
25	8630016	1	O-Ring	
26	8584007	1	Tie Wrap, 5in - Oil Cooler Hose Support	
27	6604882	1	Hose, .50 I.D. x 62in Long	
28	8765204	1	Elbow, 90, SAE 8 - male JIC 37 x female JIC 37, swivel (8042 & 10042)	
28	8760495	1	Tee, Female Branch, SAE 8 - male JIC 37 x female JIC 37, swivel (10054 Only)	
29	8760415	1	Nut, SAE 16 - JIC 37	
30	8770159	1	Reducer, Tube End, SAE 16-8 - JIC 37	
31	8760529	1	Tee, Female Run, SAE 16 - male JIC 37 x female JIC 37, swivel	
32	8760311	1	Elbow, 90, SAE 6 - male JIC 37 x male str thd o-ring	
33	8760276	1	Elbow, 45, SAE 6 - male JIC 37 x female JIC 37, swivel	
34	8760451	1	Plug, Hex Hd, SAE 6 - male str thd o-ring	
35	8405209	1	Clamp, T-Bolt Band	
36	8303519	4	HHCS M12 x 40mm	
37	8307025	4	Washer, Lock M12	
38	8307220	4	Washer, Flat M12	

SECTION 5 - HYDRAULIC CIRCUITS

FIGURE 5-5. BOOM RAISE/LOWER AND EXTEND/RETRACT CIRCUIT (Prior to SN 9909)

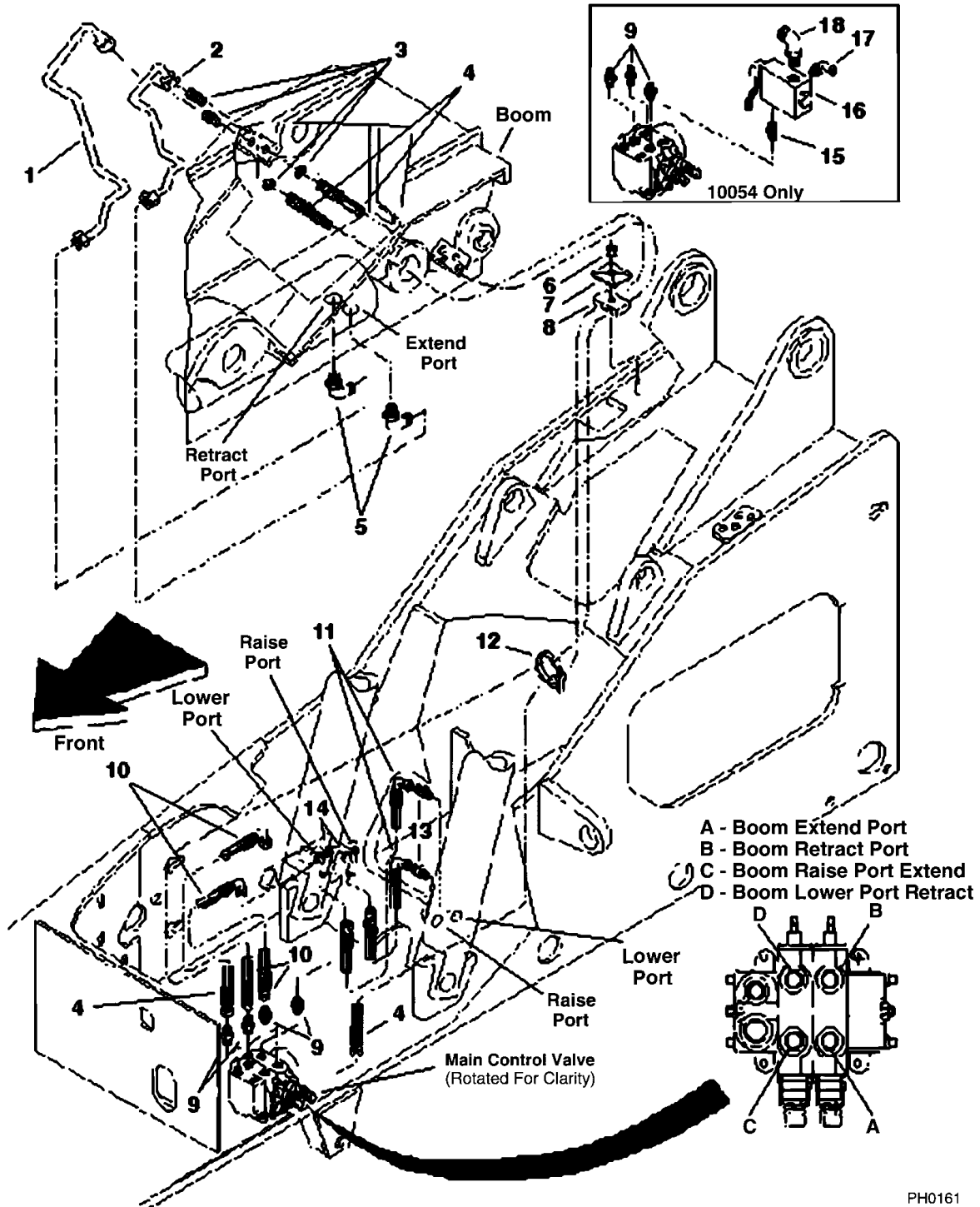

SECTION 5 - HYDRAULIC CIRCUITS

FIGURE 5-5. BOOM RAISE/LOWER AND EXTEND/RETRACT CIRCUIT (Prior to SN 9909)

ITEM	PART NUMBER	QTY	DESCRIPTION	REV
1	7133802	1	Tube, Boom Ext Cyl	
2	7133812	1	Tube, Boom Ext Cyl	
3	8760039	2	Union, Bulkhead, Straight, SAE 12 - male JIC 37	
4	2713262	2	Hose, .62 I.D. x 148in Long	
5	8760305	2	Elbow, 90, SAE 12 - male JIC 37 x male str thd o-ring	
6	8305626	1	Nut, Hex Lock Elastic 5/16-18	
7	8769128	1	Cover, Clamp	
8	8769127	1	Clamp, Twin (Only half used)	
9	8760109	4	Connector, Straight, SAE 12 - male JIC 37 x male str thd o-ring (8042/10042 Only)	
9	8760109	3	Connector, Straight, SAE 12 - male JIC 37 x male str thd o-ring (10054 Only)	
10	2713282	2	Hose, .62 I.D. x 52in Long	
11	2711852	2	Hose, .50 I.D. x 21in Long	
12	8584007	1	Tie Wrap, Heavy Duty 5in	
13	8760111	2	Connector, Straight, SAE 8-12 - male JIC 37 x male str thd o-ring	
14	8760483	2	Tee, Male Branch, SAE 12 - male JIC 37 x male str thd o-ring	
15	8770030	1	Union, SAE 12 - male str thd o-ring	
16	8902251	1	Valve, Boom Extend Lockout	
17	8770012	1	Elbow, 90, SAE 6-4 - male JIC 37 x male str thd o-ring	
18	8760317	1	Elbow, 45, SAE 12 - male JIC 37 x male str thd o-ring	

SECTION 5 - HYDRAULIC CIRCUITS

FIGURE 5-6. BOOM RAISE/LOWER AND EXTEND/RETRACT CIRCUIT (SN 9909 through 13197)

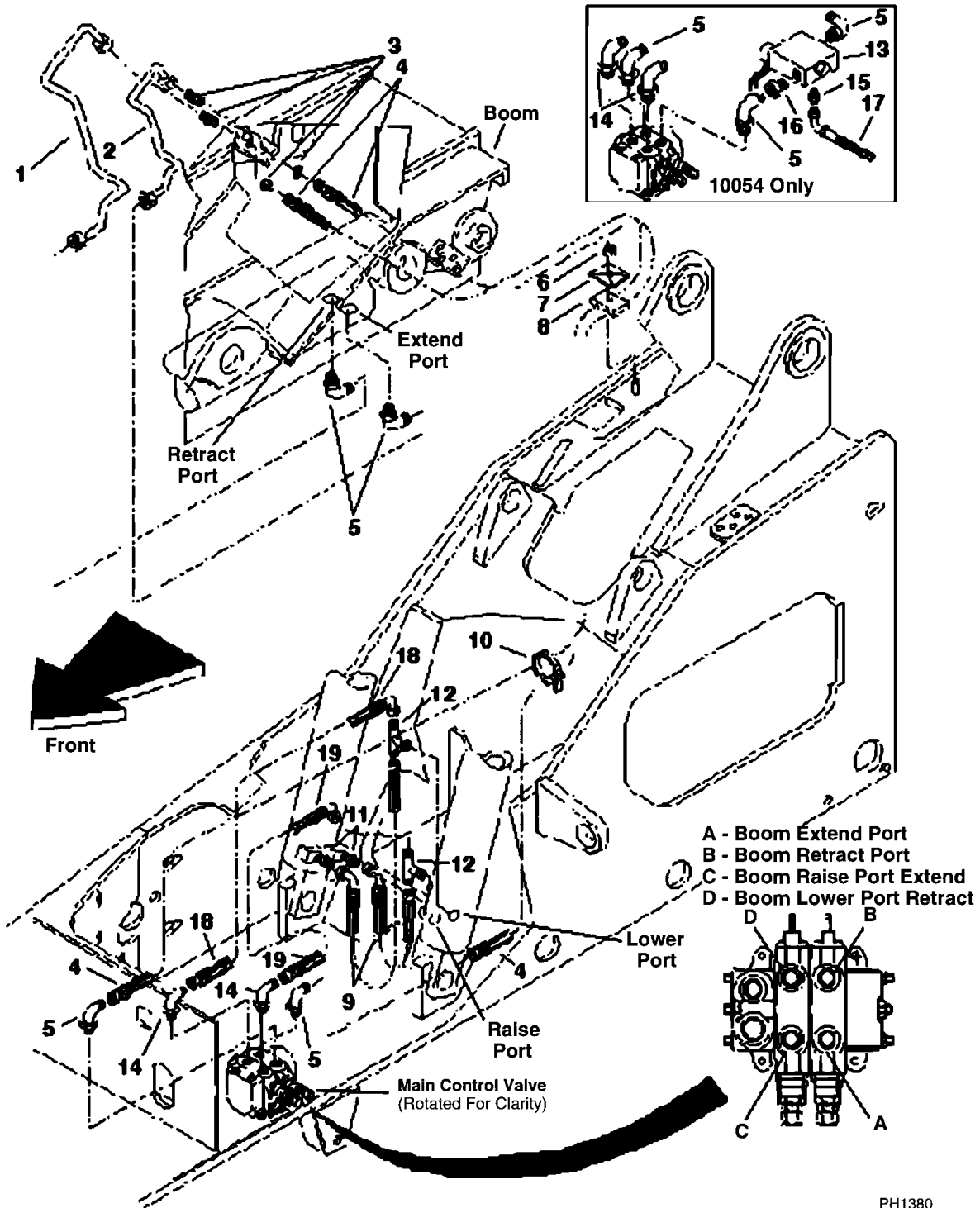

SECTION 5 - HYDRAULIC CIRCUITS

FIGURE 5-6. BOOM RAISE/LOWER AND EXTEND/RETRACT CIRCUIT (SN 9909 through 13197)

ITEM	PART NUMBER	QTY	DESCRIPTION	REV
1	7133802	1	Tube, Boom Ext Cyl	
2	7133812	1	Tube, Boom Ext Cyl	
3	8760039	2	Union, Bulkhead, Straight, SAE 12 - male JIC 37	
4	7150452	2	Hose, .62 I.D. x 148in Long	
5	8760305	5	Elbow, 90, SAE 12 - male JIC 37 x male str thd o-ring	
6	8305626	1	Nut, Hex Lock Elastic 5/16-18	
7	8769128	1	Cover, Clamp	
8	8769127	1	Clamp, Twin (Only half used)	
9	2711852	2	Hose, .50 I.D. x 21in Long	
10	8584007	1	Tie Wrap, Heavy Duty 5in	
11	8760111	2	Connector, Straight, SAE 8-12 - male JIC 37 x male str thd o-ring	
12	8760483	2	Tee, Male Branch, SAE 12 - male JIC 37 x male str thd o-ring	
13	8902251	1	Valve, Boom Extend Lockout	
14	8770157	2	Elbow, Long, 90, SAE 12-12 - male JIC 37 x male str thd o-ring	
15	8760134	1	Connector, Straight, SAE 6-4 - male JIC 37 x male str thd o-ring	
16	8760138	1	Connector, Straight, SAE 12-12 - male str thd o-ring x female JIC 37, swivel	
17	2716516	1	Hose, .38 I.D. x 16in Long	
18	7150442	1	Hose, .625 I.D. x 38in Long	
19	7150432	1	Hose, .625 I.D. x 34.5in Long	

SECTION 5 - HYDRAULIC CIRCUITS

FIGURE 5-7. ATTACHMENT TILT AND SLAVE CIRCUIT

ITEM	PART NUMBER	QTY	DESCRIPTION	REV
1	8303752	2	HHCS, 5/16-18 x 3-1/2in	
2	8307004	2	Washer, Lock 5/16in	
3	8769149	1	Cover Plate, Single Clamp	
4	8750003	4	Clamp, .62 Dia Single (8042/10042 Only)	
4	8750003	6	Clamp, .62 Dia Single (10054 Only)	
5	8769161	2	Clamp, .75 Dia Single (8042/10042 Only)	
6	2713452	2	Hose Assembly, Boom (8042/10042 Only)	
7	8303739	3	HHCS, 5/16-18 x 1-1/4in	
8	8769123	5	Cover Plate, Twin	
9	8769122	3	Clamp, .62 Dia Twin	
10	7133823	1	Tube, Boom Attachment Tilt - Retract	
11	7133833	1	Tube, Boom Attachment Tilt - Extend	
12	8760037	2	Union, Bulkhead, Straight, SAE 10 - male JIC 37	
13	2713222	2	Hose, .50 I.D. x 34in Long	
14	6605202	2	Hose, .50 I.D. x 44-1/2in Long	
15	8760477	2	Tee, Bulkhead, Male Run, SAE 8 - male JIC 37	
16	6604982	2	Hose, .50 I.D. x 22in Long	
17	8760493	2	Tee, Female Run, SAE 8 - male JIC 37 x female JIC 37, swivel	
18	2712872	2	Hose, .50 I.D. x 153in Long	
19	8760143	1	Connector, Long, SAE 8 - male JIC 37 x male str thd o-ring	
20	8760107	7	Connector, Straight, SAE 8 - male JIC 37 x male str thd o-ring (8042/10042 Only)	
20	8760107	5	Connector, Straight, SAE 8 - male JIC 37 x male str thd o-ring (10054 Only)	
21	8760307	2	Elbow, 45, SAE 8 - male JIC 37 x male str thd o-ring (10054 Only)	
22	7112452	1	Hose and Carrier Assembly (Includes Items 23 thru 25) (10054 Only)	
23	2713642	4	Hose Assembly	
24	N.S.S.	1	Carrier, Hose (For Service, Order Item 22)	
25	8584001	2	Tie Wrap	
26	8769140	1	Clamp Set, .675 twin	
27	8305626	1	Nut, Hex Lock 5/16-18	
28	8526048	AR	Sealant	
		Ref	KITS	
29	7117812	1	Kit, Hose Carrier Update	
		Ref	NOTE: Kit Purpose: To bring Early Production Hose Carrier (Item 24) up-to-date with solid bars in every other link instead of in every link, with poly rollers added to bars, and with adhesive patch coated screws instead of liquid sealant application.	

SECTION 5 - HYDRAULIC CIRCUITS

FIGURE 5-8. FRAME TILT AND STABILIZER CIRCUIT

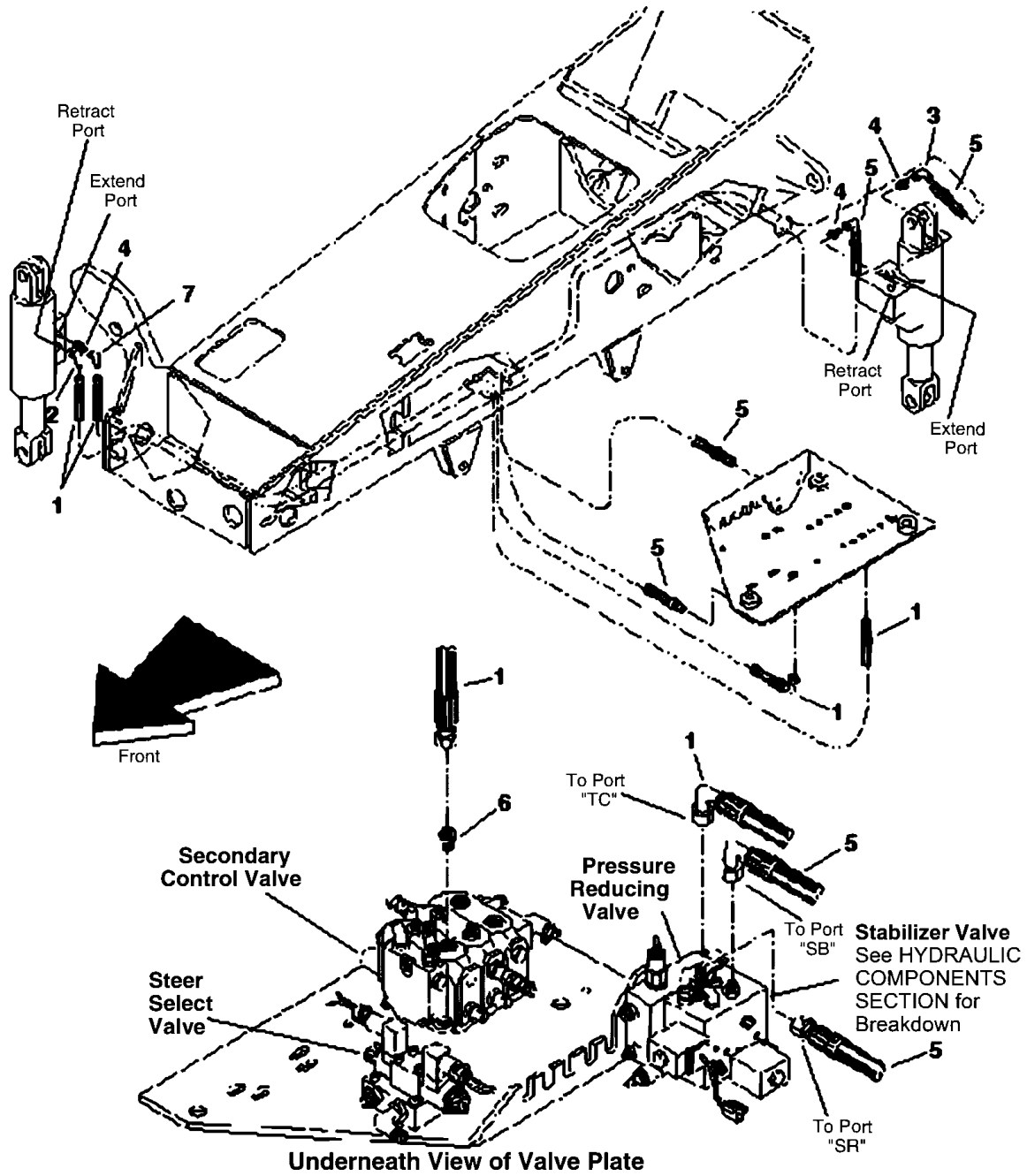

PH0181

SECTION 5 - HYDRAULIC CIRCUITS

FIGURE 5-8. FRAME TILT AND STABILIZER CIRCUIT

ITEM	PART NUMBER	QTY	DESCRIPTION	REV
1	2711892	2	Hose, .38 I.D. x 130in Long	
2	8770012	1	Elbow, 90, SAE 6-4 - male JIC 37 x male str thd o-ring	
3	8760276	1	Elbow, 45, SAE 6 - male JIC 37 x female JIC 37, swivel	
4	8760134	3	Connector, Straight, SAE 6-4 - male JIC 37 x male str thd o-ring	
5	2713332	2	Hose, .38 I.D. x 96in Long	
6	8760110	1	Connector, Straight, SAE 6-8 - male JIC 37 x male str thd o-ring	
7	8760268	1	Elbow, 90, SAE 6 - male JIC 37 x female JIC 37, swivel	

SECTION 5 - HYDRAULIC CIRCUITS

FIGURE 5-9. SERVICE BRAKE AND DE-CLUTCH CIRCUIT

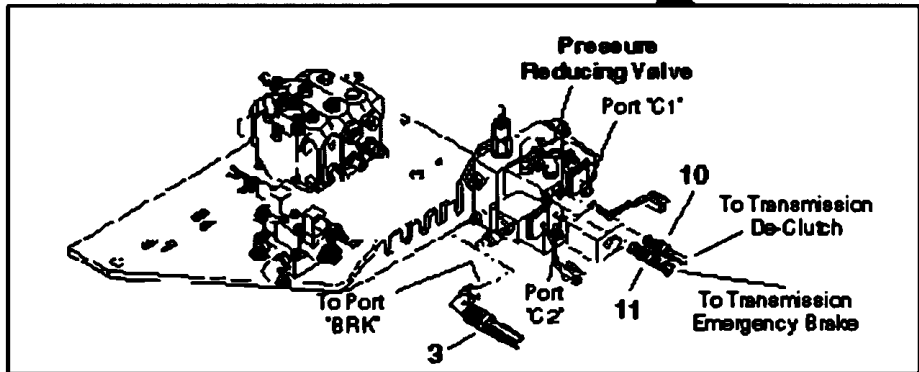
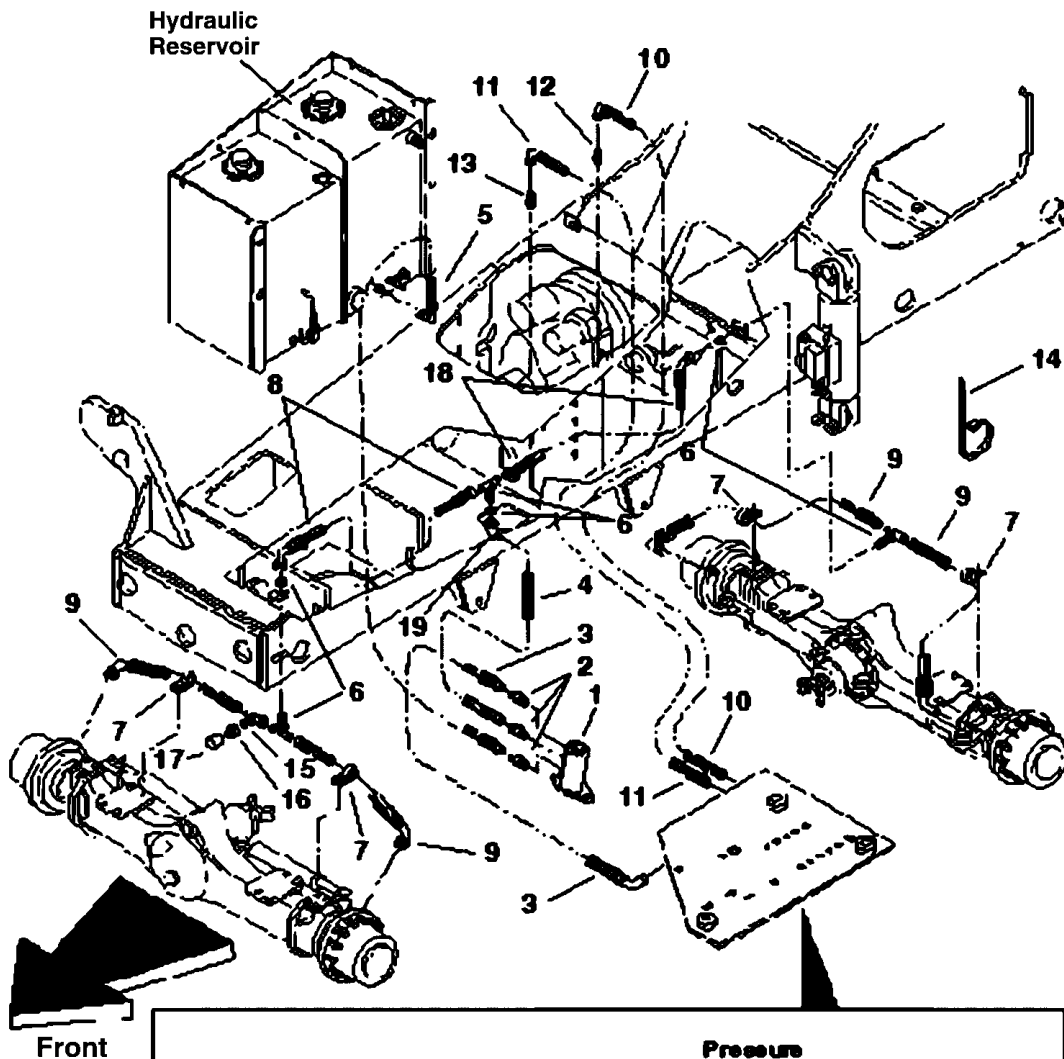

Underneath View of Valve Plate - See VALVE PLATE ASSEMBLY for Breakdown

PH0193

SECTION 5 - HYDRAULIC CIRCUITS

FIGURE 5-9. SERVICE BRAKE AND DE-CLUTCH CIRCUIT

ITEM	PART NUMBER	QTY	DESCRIPTION	REV
1	NLA	1	Valve, Brake, For Service, Order P/N 8902222 (Prior to SN 0654)	
1	7119813	1	Kit, Brake Valve (SN 0654 through 1167)	
1	8902222	1	Valve, Brake (SN 1168 to Present)	
2	8760110	3	Connector, Straight, SAE 6-8 - male JIC 37 x male str thd o-ring	
3	2712332	1	Hose, .38 I.D. x 50in Long	
4	2705122	1	Hose, .38 I.D. x 50in Long	
5	6604972	1	Hose, .38 I.D. x 90in Long	
6	8760455	3	Tee, Bulkhead, Male Branch, SAE 6 - male JIC 37	
7	8406105	4	Clamp	
8	6605772	1	Hose, .38 I.D. x 66in Long	
9	2712092	4	Hose, .25 I.D. x 49in Long	
10	6611752	1	Hose, .25 I.D. x 52in Long	
11	6604712	1	Hose, .25 I.D. x 28in Long	
12	8760011	1	Connector, Straight, SAE 4-2P - male JIC 37 x male NPT	
13	8760113	1	Connector, Straight, SAE 4 - male JIC 37 x male str thd o-ring	
14	8584007	1	Tie Wrap, 5in (Hose Support)	
15	8760501	1	Tee, Female Run, SAE 6 - male JIC 37 x female JIC 37, swivel (SN 9909 to Present)	
16	8430046	1	Nipple, Diagnostic (SN 9909 to Present)	
17	8430032	1	Plug, Dust (SN 9909 to Present)	
18	2712012	1	Hose, .38 I.D. x 75in Long (Prior to SN 9909)	
18	6605772	1	Hose, .38 I.D. x 66in Long (SN 9909 to Present)	
19	8760276	1	Elbow, 45, SAE 6 - male JIC 37 x female JIC 37, swivel (SN 9909 to Present)	

SECTION 5 - HYDRAULIC CIRCUITS

FIGURE 5-10. VALVE PLATE ASSEMBLY (WITHOUT OUTRIGGERS 8042 ONLY)

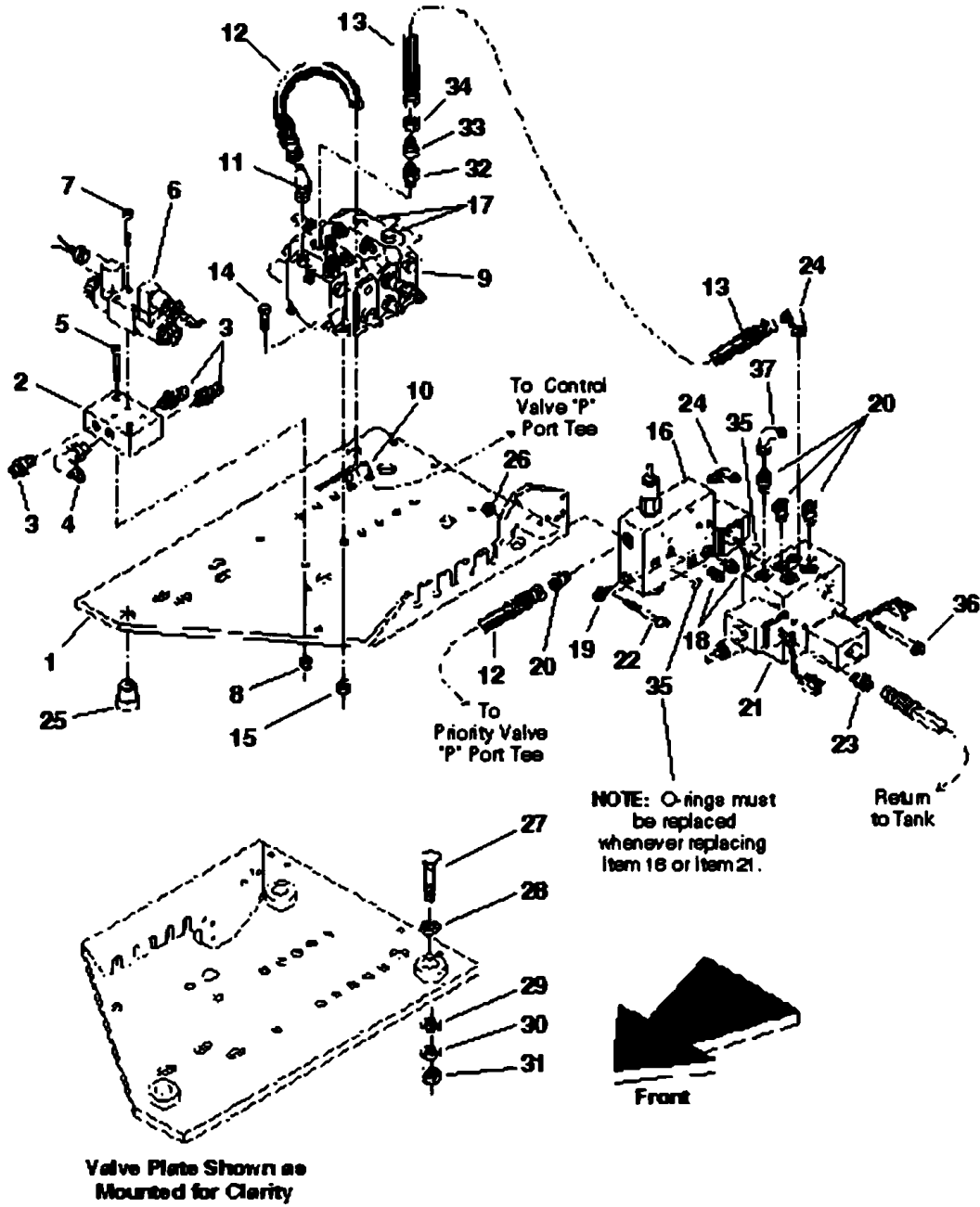

Valve Plate Shown as Mounted for Clarity

PH0122

SECTION 5 - HYDRAULIC CIRCUITS

FIGURE 5-10. VALVE PLATE ASSEMBLY (WITHOUT OUTRIGGERS 8042 ONLY)

ITEM	PART NUMBER	QTY	DESCRIPTION	REV
1	7098293	1	Plate, Valve Mounting	
2	8902111	1	Body, Steer Select Valve	
3	8760110	3	Connector, Straight, SAE 6-8 - male JIC 37 x male str thd o-ring	
4	8760313	1	Elbow, 90, SAE 6-8 - male JIC 37 x male str thd o-ring	
5	8304608	2	SHCS, 5/16-18 x 1-1/2in	
6	8902137	1	Valve, Steer Select (See HYDRAULIC COMPONENTS SECTION for Breakdown)	
7	8304631	4	SCHS, #10-24 x 2in	
8	8305626	2	Nut, Lock 5/16-18	
9	7115712	1	Kit, Secondary Control Valve (Does Not Include Fittings) (See HYDRAULIC COMPONENTS SECTION for Breakdown) (8042 Prior to SN 0267)	
9	8902152	1	Secondary Control Valve (Does Not Include Fittings) (See HYDRAULIC COMPONENTS SECTION for Breakdown) (8042 SN 0267 to Present)	
10	8584001	1	Tie Wrap, 3/16in Wide x 6-11/16in Long	
11	8760303	1	Elbow, 90, SAE 8 - male JIC 37 x male str thd o-ring	
12	6604882	2	Hose, 1/2in I.D. x 62in Long	
13	6605652	1	Hose, 3/8in I.D. x 19in Long	
14	8303675	3	HHCS, 3/8-16 x 1-1/4in	
15	8305645	3	Nut, Lock 3/8-16	
16	8902255	1	Valve, Pressure Reducing (See HYDRAULIC COMPONENTS SECTION for Breakdown) (Prior to SN 0654)	
16	8902266	1	Valve, Pressure Reducing (See HYDRAULIC COMPONENTS SECTION for Breakdown) (SN 0654 to Present)	
17	8760419	2	Plug, Hex Hd, SAE 8 - male str thd o-ring	
18	8760113	2	Connector, Straight, SAE 4 - male JIC 37 x male str thd o-ring	
19	8760136	1	Connector, Straight, SAE 4-6 - male JIC 37 x male str thd o-ring	
20	8760107	1	Connector, Straight, SAE 8 - male JIC 37 x male str thd o-ring	
21	8902267	1	Valve, Axle Stabilizer (See HYDRAULIC COMPONENTS SECTION for Breakdown)	
22	8310137	2	SHCS, 1/4-20 x 2-1/2in	
23	8760117	4	Connector, Straight, SAE 6 - male JIC 37 x male str thd o-ring	
24	8760311	2	Elbow, 90, SAE 6 - male JIC 37 x male str thd o-ring	
25	8278008	4	Isolator	
26	8305624	2	Nut, Lock 1/4-20	
27	8304042	4	Bolt, Carriage 3/8-16 x 2in	
28	8310070	4	Bolt, Retainer 3/8in	
29	7057141	4	Washer, Rebound	
30	8307005	4	Washer, Lock 3/8in	
31	8305008	4	Nut, Hex 3/8-16	
32	8760107	1	Connector, Straight, SAE 8 - male JIC 37 x male str thd o-ring	
33	8760458	1	Reducer, Tube End, SAE 8-6 - JIC 37	
34	8760407	1	Nut, SAE 8 - JIC 37	
35	8630000	2	O-Ring	
36	8310153	4	SHCS, 1/4-20 x 3in	
37	8760268	1	Elbow, 90, SAE 6 - male JIC 37 x female JIC 37, swivel	

SECTION 5 - HYDRAULIC CIRCUITS

FIGURE 5-11. VALVE PLATE ASSEMBLY (WITH OUTRIGGERS 10042/10054 ONLY)

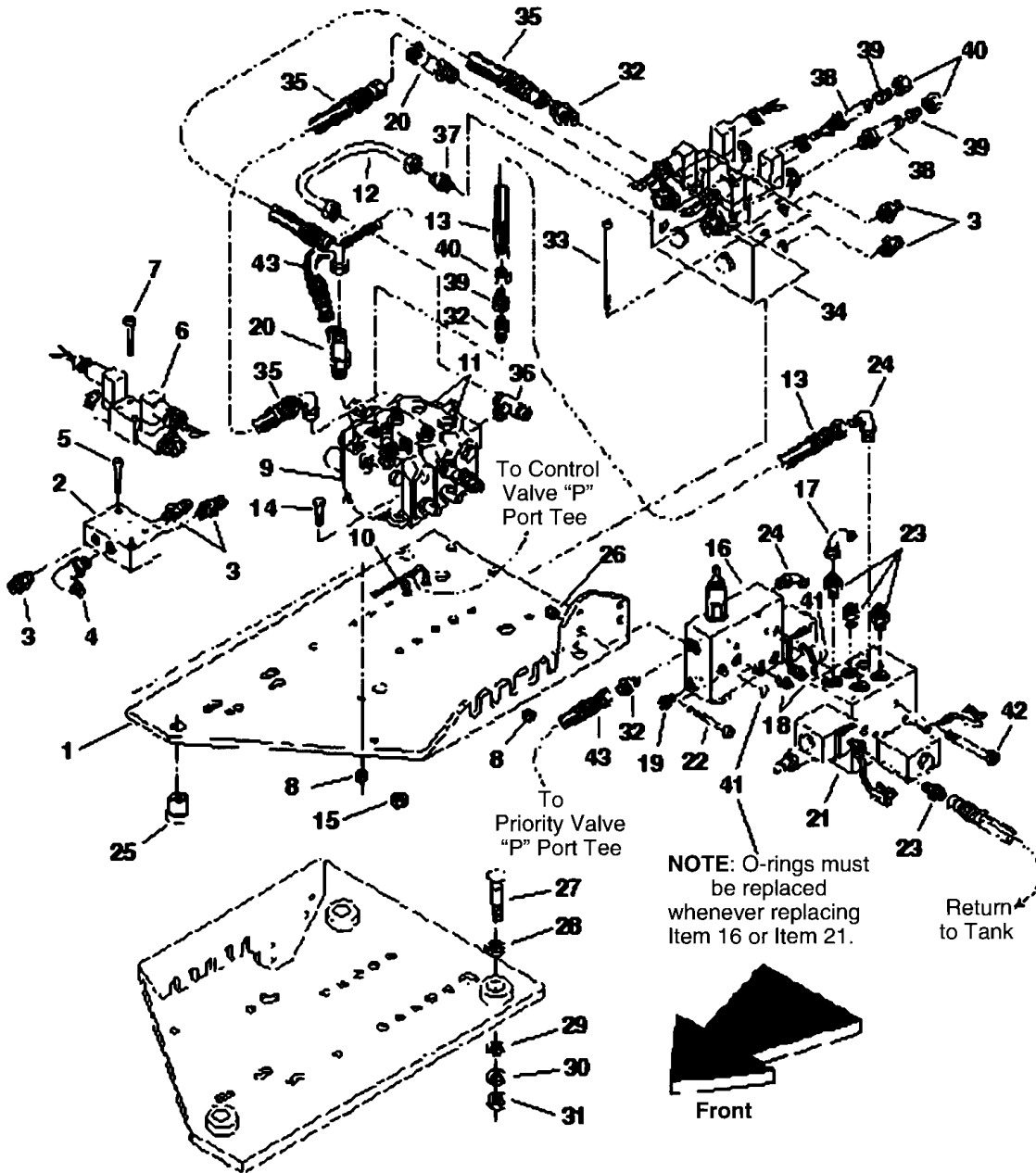

Valve Plate Shown as Mounted for Clarity

PH0112

SECTION 5 - HYDRAULIC CIRCUITS

FIGURE 5-11. VALVE PLATE ASSEMBLY (WITH OUTRIGGERS 10042/10054 ONLY)

ITEM	PART NUMBER	QTY	DESCRIPTION	REV
1	7098293	1	Plate, Valve Mounting	
2	8902111	1	Body, Steer Select Valve	
3	8760110	5	Connector, Straight, SAE 6-8 - male JIC 37 x male str thd o-ring	
4	8760313	1	Elbow, 90, SAE 6-8 - male JIC 37 x male str thd o-ring	
5	8304608	2	SHCS, 5/16-18 x 1-1/2in	
6	8902137	1	Valve, Steer Select (See HYDRAULIC COMPONENTS SECTION for Breakdown)	
7	8304631	4	SCHS, #10-24 x 2in	
8	8305626	4	Nut, Lock 5/16-18	
9	7115712	1	Kit, Secondary Control Valve (Does Not Include Fittings) (See HYDRAULIC COMPONENTS SECTION for Breakdown) (Prior to SN 0267)	
9	8902152	1	Secondary Control Valve (Does Not Include Fittings (See HYDRAULIC COMPONENTS SECTION for Breakdown) (SN 0267 to Present)	
10	8584001	1	Tie Wrap, 3/16in Wide x 6-11/16in Long	
11	8760419	2	Plug, Hex Hd, SAE 8 - male str thd o-ring	
12	7111122	1	Tube Assembly (Prior to SN 10882)	
12	2716545	1	Hose, .38 x 17 (SN 10882 to Present)	
13	6605652	1	Hose, 3/8in I.D. x 19in Long	
14	8303675	3	HHCS, 3/8-16 x 1-1/4in	
15	8305645	3	Nut, Lock 3/8-16	
16	8902266	1	Valve, Pressure Reducing (See HYDRAULIC COMPONENTS SECTION for Breakdown)	
17	8760268	1	Elbow, 90, SAE 6 - male JIC 37 x female JIC 37, swivel	
18	8760113	2	Connector, Straight, SAE 4 - male JIC 37 x male str thd o-ring	
19	8760136	1	Connector, Straight, SAE 4-6 - male JIC 37 x male str thd o-ring	
20	8760510	2	Tee, Male Run, SAE 8 - male JIC 37 x male str thd o-ring	
21	8902267	1	Valve, Stabilizer (See HYDRAULIC COMPONENTS SECTION for Breakdown)	
22	8310137	2	SHCS, 1/4-20 x 2-1/2in	
23	8760117	4	Connector, Straight, SAE 6 - male JIC 37 x male str thd o-ring	
24	8760311	2	Elbow, 90, SAE 6 - male JIC 37 x male str thd o-ring	
25	8278008	4	Isolator	
26	8305624	2	Nut, Lock 1/4-20	
27	8304042	4	Bolt, Carriage 3/8-16 x 2in	
28	8310070	4	Bolt, Retainer 3/8in	
29	8307204	4	Washer, Flat 3/8in	
30	8307005	4	Washer, Lock 3/8in	
31	8305008	4	Nut, Hex 3/8-16	
32	8760107	3	Connector, Straight, SAE 8 - male JIC 37 x male str thd o-ring	
33	8310138	2	SHCS, 5/16-18 x 4in (Prior to SN 10882)	
33	8310081	2	SHCS, 5/16-18 x 4 (SN 10882 to Present)	
34	8902141	1	Valve, Outrigger (See HYDRAULIC COMPONENTS SECTION for Breakdown) (Prior to SN 10882)	
34	8902193	1	Valve, Outrigger (See HYDRAULIC COMPONENTS SECTION for Breakdown) (SN 10882 to Present)	
35	2713322	2	Hose, 1/2in I.D. x 35in Long	
36	8760459	1	Tee, Female Branch, SAE 6-6 - male JIC 37 x female JIC 37, swivel	
37	8760117	1	Connector, Straight, SAE 6 - male JIC 37 x male str thd o-ring (Prior to SN 10882)	
37	8760141	1	Connector, Male Tube End w/Outlet Check, 6-6 (SN 10882 to	

SECTION 5 - HYDRAULIC CIRCUITS

ITEM	PART NUMBER	QTY	DESCRIPTION	REV
38	8760143	2	Present) Connector, Long, SAE 8 - male JIC 37 x male str thd o-ring (Prior to SN 10882)	
38	8760117	2	Connector, Straight, SAE 6 - male JIC 37 x male str thd o-ring (SN 10882 to Present)	
39	8760458	3	Reducer, Tube End, SAE 8-6 - JIC 37, (Prior to SN 10882)	
39	8760460	2	Reducer, SAE 8-6 - male str thd o-ring x female internal o-ring boss (SN 10882 to Present)	
40	8760407	3	Nut, SAE 8 - JIC 37, (Prior to SN 10882)	
41	8630000	2	O-Ring	
42	8310153	4	SHCS, 1/4-20 x 3in	
43	6604882	2	Hose, 1/2in I.D. x 62in Long	

SECTION 5 - HYDRAULIC CIRCUITS

FIGURE 5-12. TRANSMISSION COOLING CIRCUIT (Prior to SN 9909)

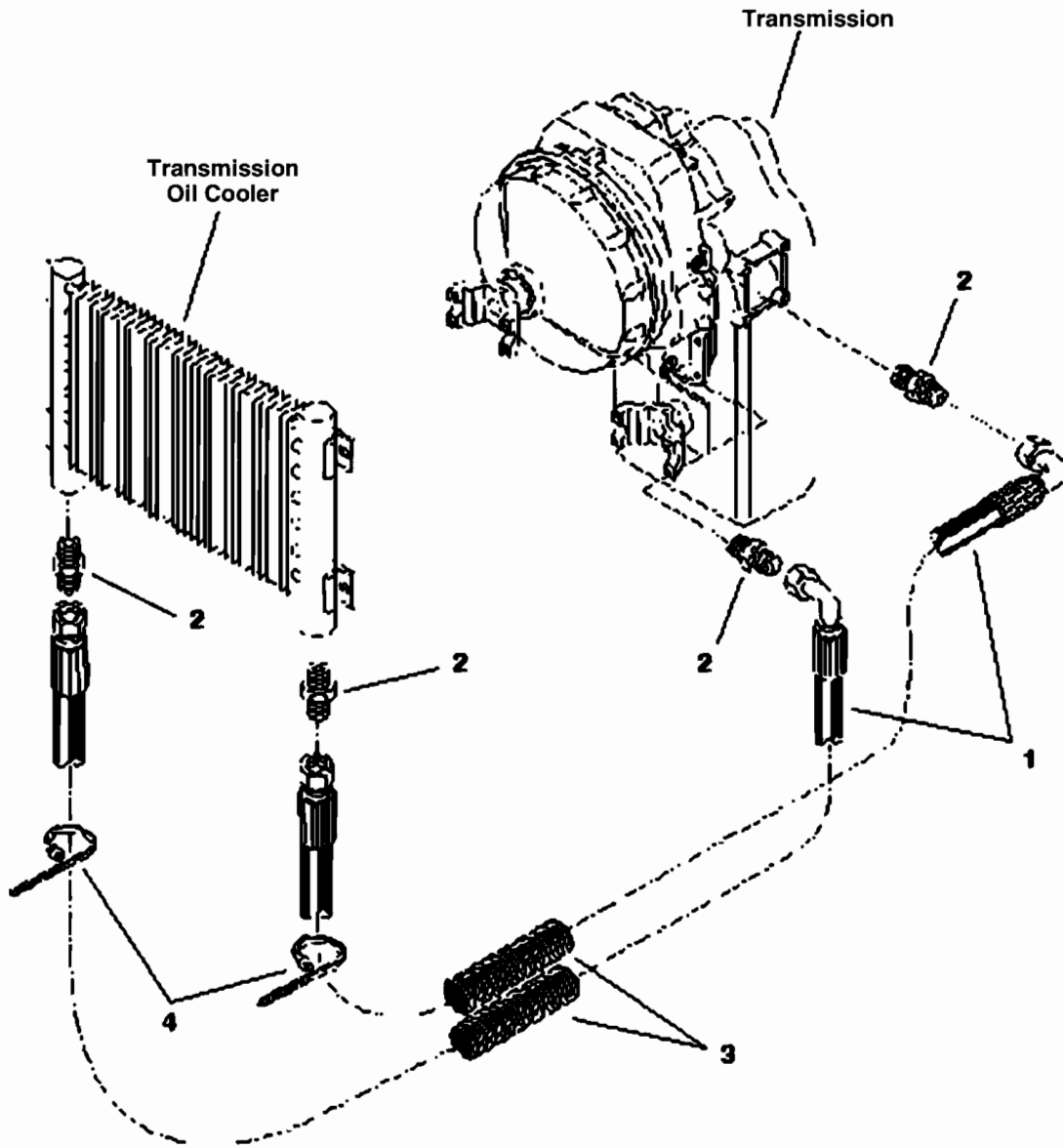

PH0202

SECTION 5 - HYDRAULIC CIRCUITS

FIGURE 5-12. TRANSMISSION COOLING CIRCUIT (Prior to SN 9909)

ITEM	PART NUMBER	QTY	DESCRIPTION	REV
1	6604912	2	Hose, .75 I.D. x 113in Long	
2	8760109	4	Connector, Straight, SAE 12 - male JIC 37 x male str thd o-ring	
3	7124471	2	Conduit, 1 I.D. x 12.5in	
4	8584007	2	Tie, plastic, .5 x 20.1in	

SECTION 5 - HYDRAULIC CIRCUITS

FIGURE 5-13. TRANSMISSION COOLING CIRCUIT (SN 9909 through 13197)

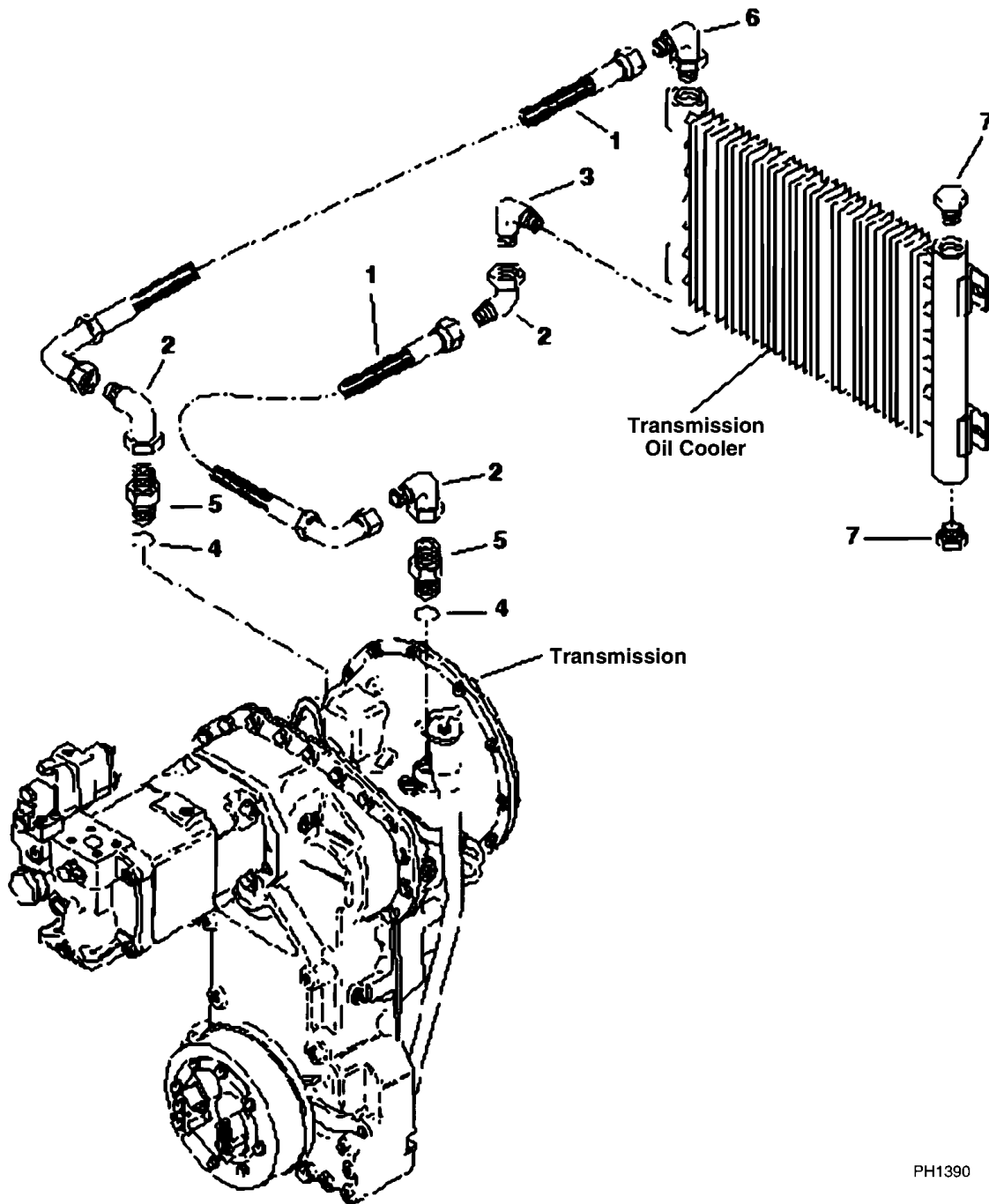

PH1390

SECTION 5 - HYDRAULIC CIRCUITS

FIGURE 5-13. TRANSMISSION COOLING CIRCUIT (SN 9909 through 13197)

ITEM	PART NUMBER	QTY	DESCRIPTION	REV
1	7150282	2	Hose, .75 I.D. x 105in Long	
2	8760254	3	Elbow, 90, SAE 12 - male JIC 37 x female JIC 37, swivel	
3	8760305	1	Elbow, 90, SAE 12 - male JIC 37 x male str thd o-ring	
4	8630017	2	O-Ring, 23mm x 2mm	
5	8770158	2	Connector, M26 x 12 - 37, Flare	
6	8770157	1	Elbow, Long, 90, SAE 12-12 - male JIC 37 x male str thd o-ring	
7	8760431	2	Plug, Hex Hd, SAE 12 - male str thd o-ring	

SECTION 5 - HYDRAULIC CIRCUITS

FIGURE 5-14. AUXILIARY HYDRAULIC CIRCUIT (OPTIONAL)

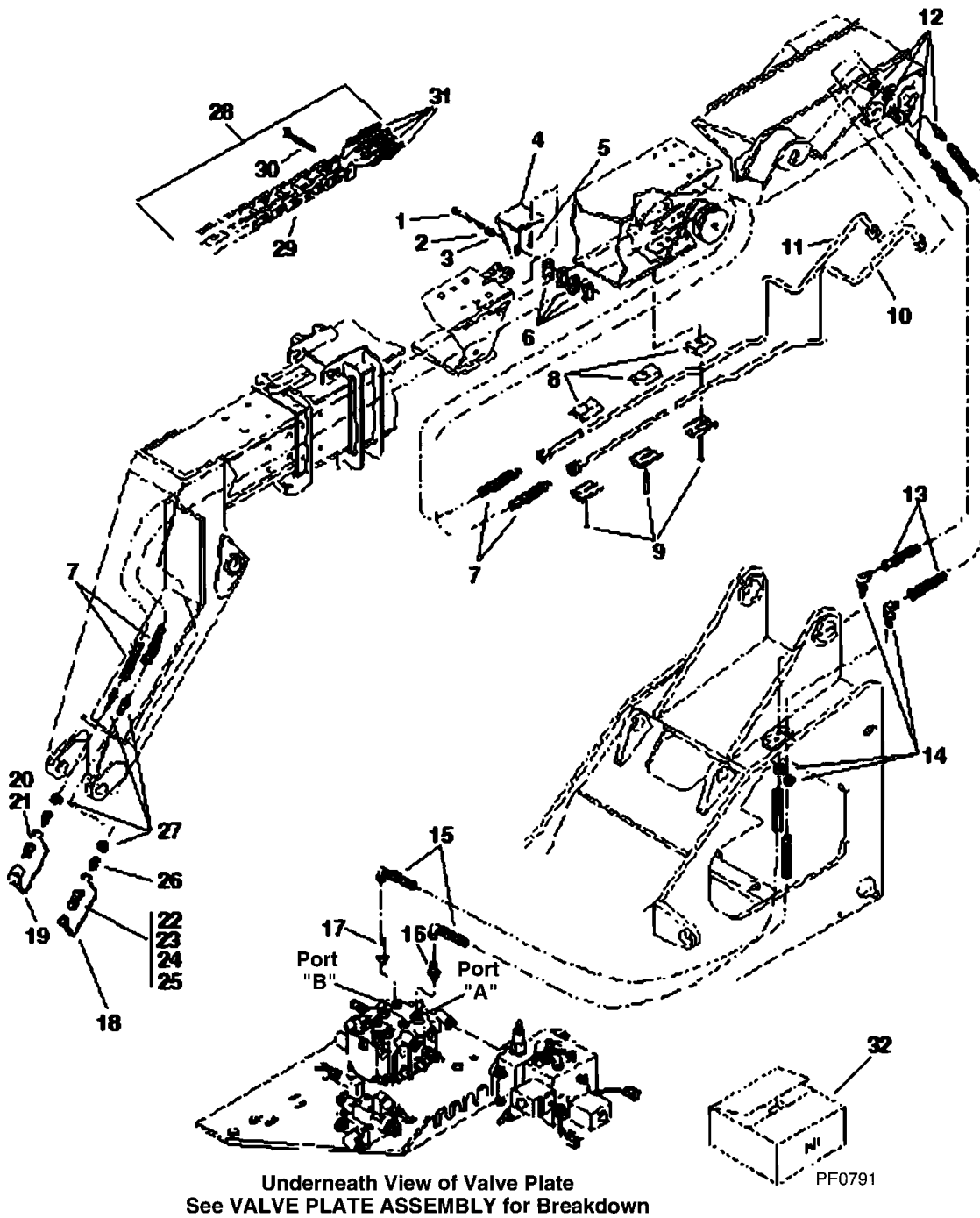

PH0212

SECTION 5 - HYDRAULIC CIRCUITS

FIGURE 5-14. AUXILIARY HYDRAULIC CIRCUIT (OPTIONAL)

ITEM	PART NUMBER	QTY	DESCRIPTION	REV
1	8310081	2	HHCS, 5/16-18 x 5in	
2	8307004	2	Washer, Lock .31in	
3	8307203	2	Washer, Flat 5/16in Heavy	
4	7111402	1	Support, Clamp	
5	8303679	2	HHCS, 3/8-16 x 1-3/4in (8042/10042 Only)	
5	8303622	2	HHCS, 3/8-16 x 2in (10054 Only)	
6	8769161	2	Clamp, Single .75 I.D. (8042/10042 Only)	
6	8750003	2	Clamp, Single .62 I.D. (10054 Only)	
7	2713082	2	Hose, .50 I.D. x 426in Long (8042/10042 Only)	
8	8769122	3	Clamp, Twin .62 I.D. (Two Halves)	
9	8303757	3	HHCS, 5/16-18 x 2-1/2in	
10	7133843	1	Tube Assembly	
11	7133853	1	Tube Assembly	
12	8760037	2	Union, Bulkhead, Straight, SAE 10 - male JIC 37	
13	2713212	2	Hose, .50 I.D. x 30in Long	
14	8760264	2	Elbow, 90, Bulkhead, SAE 8 - male JIC 37	
15	2712872	2	Hose, .50 I.D. x 153in Long	
16	8760107	1	Connector, Straight, SAE 8 - male JIC 37 x male str thd o-ring	
17	8760143	1	Connector, Long, SAE 8 - male JIC 37 x male str thd o-ring	
18	8420055	1	Plug, Dust #8	
19	8420053	1	Cap, Dust #8	
20	8430006	1	Quick Disconnect, Male, SAE 8-8ORB - female internal (Includes Item 21)	
21	8640029	1	Seal, Nose (Not Shown)	
22	8430005	1	Quick Disconnect, Female, SAE 8-8ORB - female internal (Includes Items 23 thru 25)	
23	8640029	1	Seal, Nose (Not Shown)	
24	8640028	1	Seal, Coupler Body (Not Shown)	
25	8640032	1	Back-Up Ring, Coupler Body Seal (Not Shown)	
26	8760142	2	Connector, Straight, SAE 8-8 - male str thd o-ring x female JIC 37, swivel	
27	8760045	2	Union, Bulkhead, Straight, SAE 8 - male JIC 37	
28	7112452	1	Hose and Carrier Assembly (Includes Items 29 thru 31) (10054 Only)	
29	N.S.S.	1	Carrier, Hose (For Service, Order Item 28)	
30	8584001	2	Tie Wrap	
31	2713642	4	Hose Assembly	
		Ref	KITS	
32	7117812	1	Kit, Hose Carrier Update	
		Ref	NOTE: Kit Purpose: To bring Early Production Hose Carrier (Item 29) up-to-date with solid bars in every other link instead of in every link, with poly rollers added to bars, and with adhesive patch coated screws instead of liquid sealant application.	

SECTION 5 - HYDRAULIC CIRCUITS

FIGURE 5-15. OUTRIGGER HYDRAULIC CIRCUIT (10042/10054 ONLY)

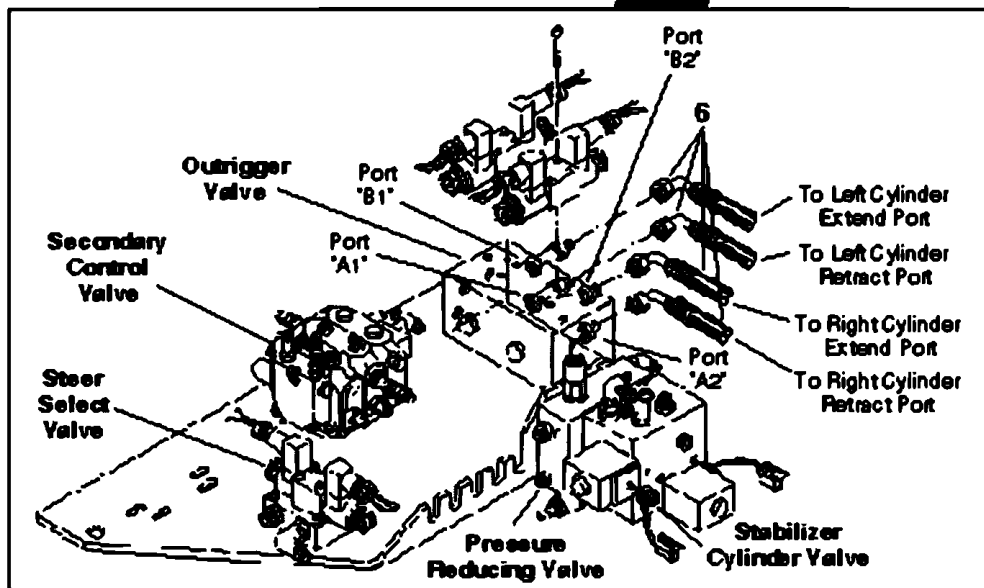
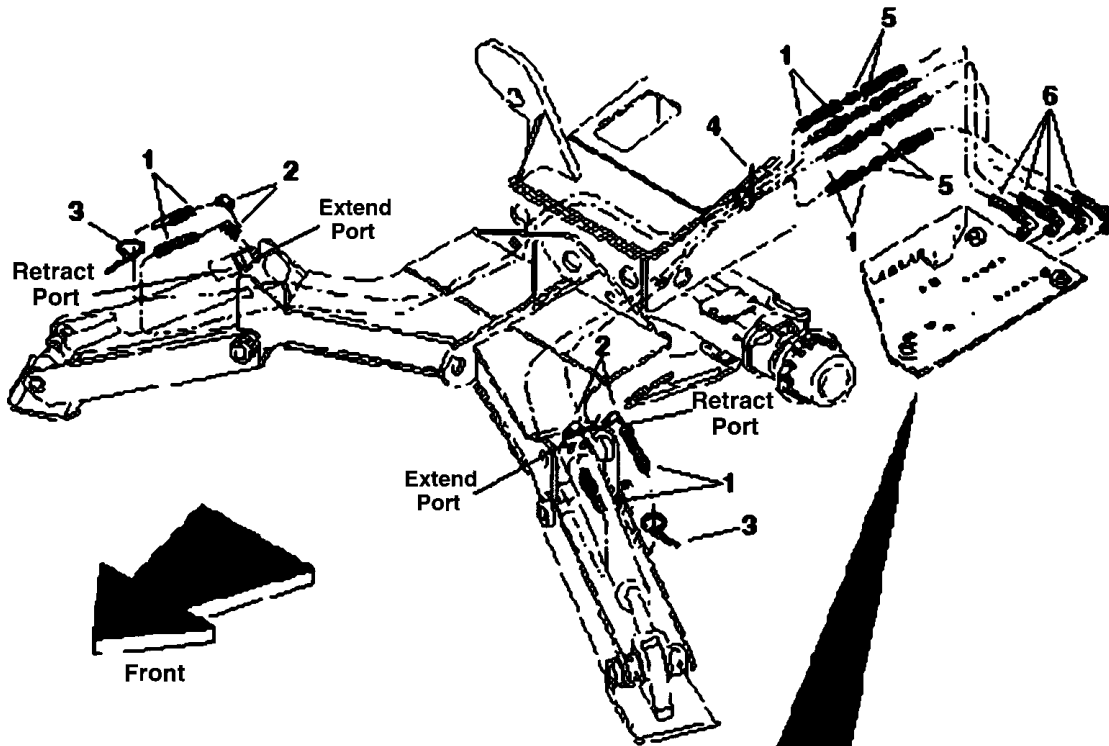

Underneath View of Valve Plate
See VALVE PLATE ASSEMBLY for Breakdown

PH0412

SECTION 5 - HYDRAULIC CIRCUITS

FIGURE 5-15. OUTRIGGER HYDRAULIC CIRCUIT (10042/10054 ONLY)

ITEM	PART NUMBER	QTY	DESCRIPTION	REV
1	2711982	4	Hose Assembly, 3/8in I.D.	
2	8760311	4	Elbow, 90, SAE 6 - male JIC 37 x male str thd o-ring	
3	8584001	2	Tie Wrap (10054 Only)	
4	8584003	1	Tie Wrap	
5	8760029	4	Union, SAE 6 - male JIC 37	
6	2712952	4	Hose Assembly, 3/8in I.D.	

SECTION 6 - HYDRAULIC COMPONENTS

SECTION 6 - HYDRAULIC COMPONENTS

FIGURE 6-1. HYDRAULIC RESERVOIR

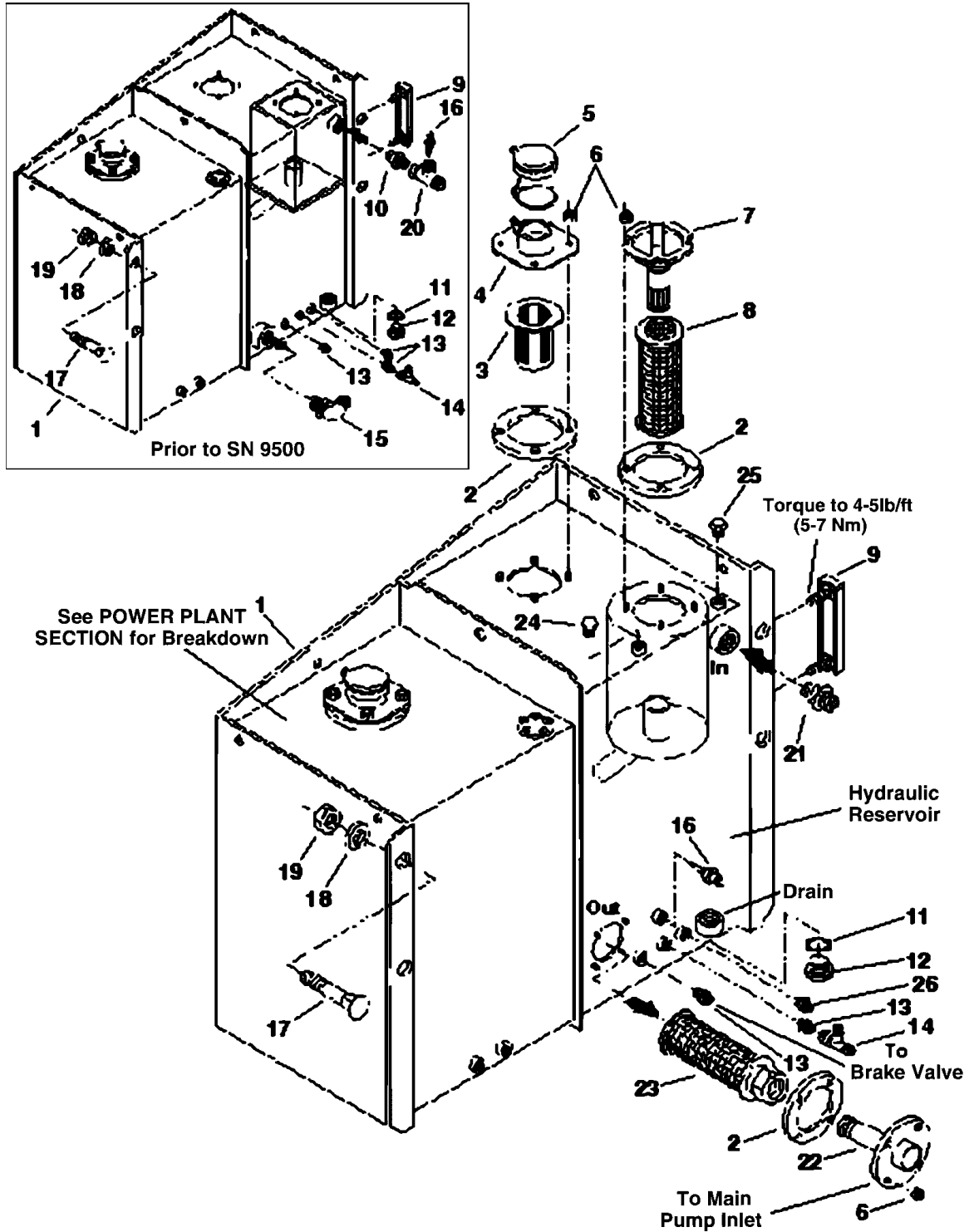

PH0103

SECTION 6 - HYDRAULIC COMPONENTS

FIGURE 6-1. HYDRAULIC RESERVOIR

ITEM	PART NUMBER	QTY	DESCRIPTION	REV
1	NLA	1	Tank, Fuel and Hydraulic (For Service, Order P/N 7136034) (Prior to SN 9500)	
1	7136034	1	Tank, Fuel and Hydraulic (SN 9500 to Present)	
2	NLA	2	Gasket (For Service, Order P/N 7138209) (Prior to SN 9500)	
2	7138209	3	Gasket (SN 9500 to Present)	
3	NLA	1	Screen, Fill Neck (For Service, Order P/N 8322022)	
4	NLA	1	Neck, Filler/Breather (For Service, Order P/N 8322022 & 7138714) (Prior to SN 9500)	
4	7138714	1	Neck, Filler/Breather (SN 9500 to Present)	
5	NLA	1	Cap, Filler (For Service, Order P/N 8322022) (Prior to SN 9500)	
5	8322029	1	Cap, Filler (SN 9500 to Present)	
6	8305626	8	Nut, Hex Lock Elastic 5/16-18 (Prior to SN 9500)	
6	8305626	12	Nut, Hex Lock Elastic 5/16-18 (SN 9500 to Present)	
7	7094562	1	Head, Filter (with by-pass)	
8	8320265	1	Element, Hydraulic Oil Filter	
9	8464012	1	Gauge, Sight	
10	8760118	1	Connector, Straight, SAE 12-16 - male JIC 37 x male str thd o-ring (Prior to SN 9500)	
11	8640903	1	O-Ring	
12	8541435	1	Plug, Magnetic, Hex Hd, 1in str thd	
13	8760110	2	Connector, Straight, SAE 6-8 - male JIC 37 x male str thd o-ring (SN 9500 to Present)	
13	8760110	3	Connector, Straight, SAE 6-8 - male JIC 37 x male str thd o-ring (Prior to SN 9500)	
14	8760501	1	Tee, Female Run, SAE 6 - male JIC 37 x female JIC 37, swivel	
15	8760351	1	Elbow, 45, SAE 24 - male JIC 37 x male str thd o-ring (Prior to SN 9500)	
16	8223217	1	Switch, Hydraulic Temperature - 210F (Prior to SN 9500)	
16	8223226	1	Switch, Hydraulic Temperature - 195F (SN 9500 to Present)	
17	8310129	4	Bolt, Carriage 5/8-11 x 2-1/2in	
18	8307009	4	Washer, Lock 5/8in	
19	8305014	4	Nut, Hex 5/8-11	
20	7098271	1	Tee, Swivel #12 Ported (Prior to SN 9500)	
21	8760102	1	Connector, Straight, SAE 16 - male JIC 37 x male str thd o-ring (SN 9500 to Present)	
22	7138164	1	Tube Assembly (SN 9500 to Present)	
23	8324029	1	Strainer (SN 9500 to Present)	
24	8760419	1	Plug, Hex Hd, SAE 8 - male str thd o-ring (SN 9500 to Present)	
25	8760451	1	Plug, Hex Hd, SAE 6 - male str thd o-ring (SN 9500 to Present)	
26	8760107	1	Connector, Straight, SAE 8 - male JIC 37 x male str thd o-ring (SN 9500 to Present)	

SECTION 6 - HYDRAULIC COMPONENTS

FIGURE 6-2. MAIN PUMP (Prior to SN 9909)

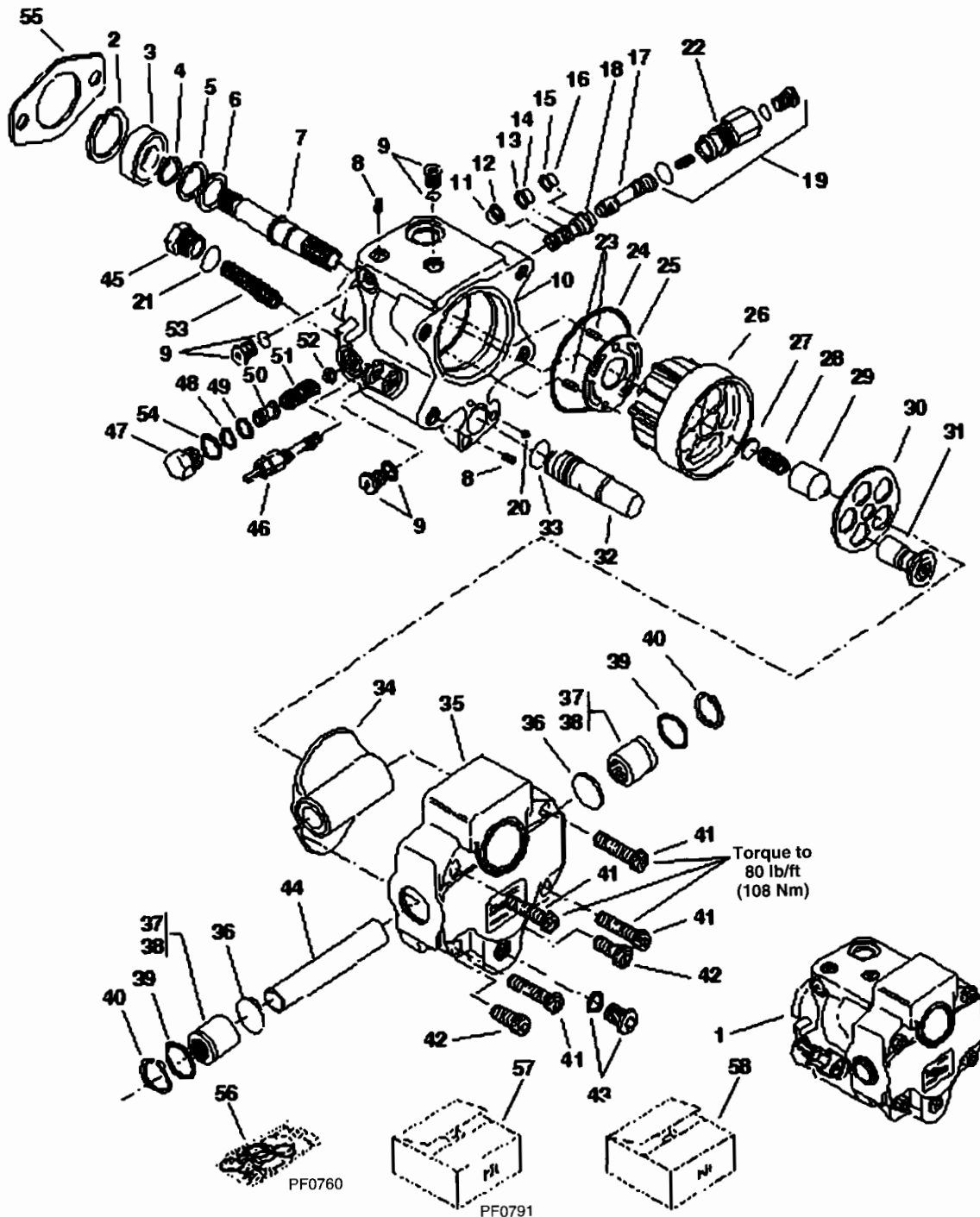

SECTION 6 - HYDRAULIC COMPONENTS

FIGURE 6-2. MAIN PUMP (Prior to SN 9909)

ITEM	PART NUMBER	QTY	DESCRIPTION	REV
1	8444223	1	Pump, Complete (Includes Items 2 thru 54) (Also must order 7135391 Kit, Relief Valve Hoist/Extend)	
2	8033896	1	Snap Ring	
3	8033897	1	Ball Bearing	
4	8033898	1	Snap Ring	
5	8033899	1	Snap Ring	
6	8033900	1	Shaft Seal	
7	8033901	1	Shaft, Spline	
8	8033902	2	Plug	
9	8033903	3	Plug	
10	8033904	1	Housing, Right Side	
11	8033905	1	O-Ring	
12	8033906	1	Back-up Ring	
13	8033907	1	Back-up Ring	
14	8033908	1	O-Ring	
15	8033909	1	Back-up Ring	
16	8033910	1	O-Ring	
17	8033911	1	Spool	
18	8033912	1	Sleeve	
19	8034818	1	Cap and Plug Assembly	
20	8033914	1	Ball	
21	8033959	1	O-Ring	
22	8033916	1	Cap Assembly, Airbleed	
23	8033917	2	Roll Pin	
24	8033918	1	O-Ring	
25	8033919	1	Port Plate, CW	
26	8033920	1	Barrel	
27	8033921	2	Retainer	
28	8033922	1	Spring, Barrel	
29	8033923	1	Ball Seat	
30	8033924	1	Retainer, Slipper	
31	8033925	7	Piston Assembly	
32	8033926	1	Piston, Servo	
33	8033927	1	O-Ring	
34	8033928	1	Swash Plate	
35	8033929	1	Housing, Trunion	
36	8033930	2	Thrust Washer	
37	8033931	2	Trunion Cap	
38	8033932	2	Needle Bearing	
39	8033933	2	O-Ring	
40	8033934	2	Snap Ring	
41	8033935	4	HHCS	
42	8033936	2	HHCS	
43	8033937	1	Plug	
44	8033938	1	Pin, Trunion	
45	8033939	1	Plug, Servo	
46	8034812	1	Screw Assembly, Adjusting	
47	8033952	1	Cap, Differential	
48	8033953	AR	Shim, Differential	
49	8033954	AR	Shim, Differential	

SECTION 6 - HYDRAULIC COMPONENTS

ITEM	PART NUMBER	QTY	DESCRIPTION	REV
50	8033955	1	Piston	
51	8033956	1	Spring, Modulator	
52	8033957	1	Spring, Retaining	
53	8033958	1	Spring, Servo	
54	8033913	1	O-Ring	
55	7099072	1	Gasket, Mounting	
		Ref	KITS	
56	8032752	1	Kit, Seal	
57	7136374	1	Kit, Retrofits to a Current Production Pump (Includes Pump, Hoses, Hardware and Instructions) (Prior to SN 9500)	
58	7138340	1	Kit, Retrofits to a Current Production Pump (Includes Pump, Hoses, Hardware and Instructions) (SN 9500 through 9908)	

SECTION 6 - HYDRAULIC COMPONENTS

FIGURE 6-3. MAIN PUMP (SN 9909 through 13197)

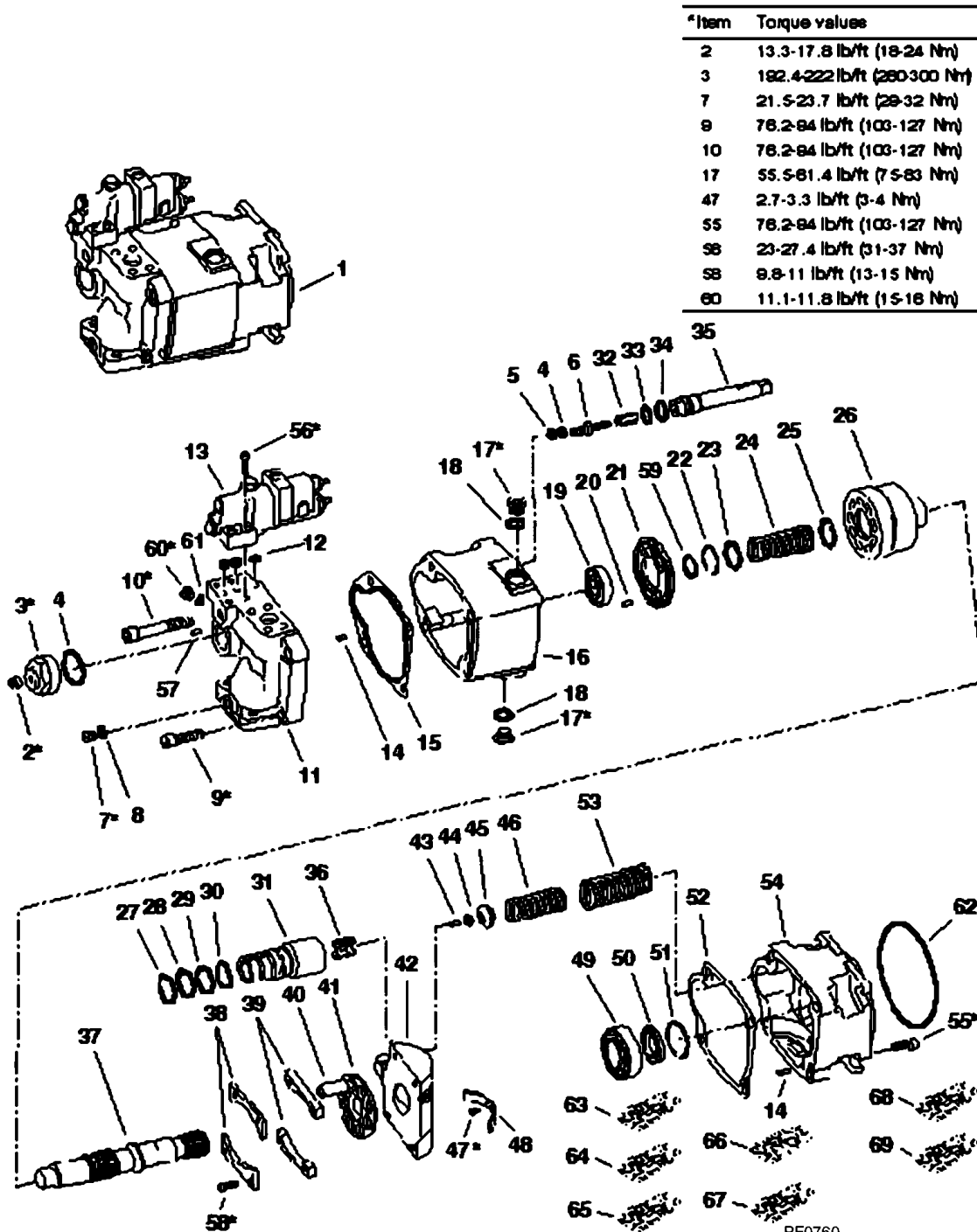

PF0760

PH1221

SECTION 6 - HYDRAULIC COMPONENTS

FIGURE 6-3. MAIN PUMP (SN 9909 through 13197)

ITEM	PART NUMBER	QTY	DESCRIPTION	REV
1	8444227		Pump, Piston, Complete (Includes Items 2 thru 61)	
2	8035567	1	Nut, Jam	
3	8035568		Cap (S Stop)	
3	8035569		Cap (F Stop)	
4	N.S.S.	1	O-Ring (Order Item 64)	
5	N.S.S.	1	Ring, Backup (Order Item 64)	
6	8035570	1	Screw, Adjustment	
7	8035571	2	Plug, SAE Gage Port	
7	8035572	2	Plug, ISO Gage Port	
8	N.S.S.	2	O-Ring (Order Item 64)	
9	8035573	3	Screw	
10	8035574	1	Screw	
11	8035575	1	Block, Valve	
12	N.S.S.	3	O-Ring (Order Item 64)	
13	N.S.S.	1	Subassembly, Control (Order Item 63)	
14	8035577	4	Pin	
15	N.S.S.	1	Gasket (Order Item 64)	
16	8035578	1	Housing	
17	8035579	2	Plug, Drain	
18	8035580	2	O-Ring	
19	N.S.S.	1	Bearing (Order Item 67)	
20	8035581	1	Pin	
21	8035582	1	Plate, Valve	
22	N.S.S.	1	Ring, Retaining (Order Item 65)	
23	N.S.S.	1	Guide, Spring (Order Item 65)	
24	N.S.S.	1	Spring (Order Item 65)	
25	N.S.S.	1	Guide, Spring (Order Item 65)	
26	N.S.S.	1	Block, Cylinder (Order Item 65)	
27	N.S.S.	1	Ring, Backup (Order Item 64)	
28	N.S.S.	1	O-Ring (Order Item 64)	
29	N.S.S.	1	O-Ring (Order Item 64)	
30	N.S.S.	1	Ring, Backup (Order Item 64)	
31	8035583	1	Sleeve, Control	
32	8035584	1	Nut, Hex	
33	N.S.S.	1	O-Ring (Order Item 64)	
34	N.S.S.	1	Ring, Glide (Order Item 64)	
35	8035585	1	Piston, Control	
36	8035586	1	Link, Chain	
37	8035587	1	Shaft	
38	N.S.S.	2	Plate, Limiter (Order Item 65)	
39	N.S.S.	2	Spacer (Order Item 65)	
40	N.S.S.	9	Subassembly, Piston and Shoes (Order Item 65)	
41	N.S.S.	1	Cage, Shoe (Order Item 65)	
42	N.S.S.	1	Yoke (Order Item 66)	
43	N.S.S.	1	Pin (Order Item 66)	
44	8035588	1	Button	
45	N.S.S.	1	Seat (Order Item 66)	
46	8035589	1	Spring	
47	N.S.S.	2	Screw (Order Item 66)	
48	N.S.S.	2	Bearing, Saddle (Order Item 66)	

SECTION 6 - HYDRAULIC COMPONENTS

ITEM	PART NUMBER	QTY	DESCRIPTION	REV
49	N.S.S.	1	Bearing (Order Item 67)	
50	N.S.S.	1	Seal, Shaft (Order Item 68)	
51	N.S.S.	1	Ring, Retaining (Order Item 68)	
52	N.S.S.	1	Gasket (Order Item 64)	
53	8035590	1	Spring	
54	8035591	1	Flange	
55	8035592	4	Screw	
56	8035593	4	Screw	
57	8035595	1	Pin	
58	8035596	4	Screw	
59	N.S.S.	1	Spacer, Shaft (Order Item 69)	
60	8035597	2	Plug	
61	8035598	2	O-Ring	
62	8630016	1	O-Ring, 130mm x 3mm	
		Ref	KITS	
63	8035560	1	Kit, Control	
64	8035561	1	Kit, Seal	
65	8035562	1	Kit, Rotating Group	
66	8035563	1	Kit, Yoke and Saddle Bearing	
67	8035564	1	Kit, Shaft Bearing	
68	8035565	1	Kit, Shaft Seal	
69	8035566	1	Kit, Shaft Spacer	

SECTION 6 - HYDRAULIC COMPONENTS

FIGURE 6-4. BOOM EXTEND CYLINDER (EARLY PRODUCTION)

IMPORTANT:

There are two similar but distinctly different Boom Extend Cylinders. Make sure you know which version you have before ordering replacement parts. On 'Early Production' cylinders, the gland is installed flush with the cylinder tube and has 'TJB' stamped on the gland. On the 'Current Production' cylinders, the gland has a lip that bottoms out against the cylinder tube.

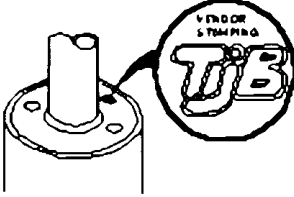

EARLY PRODUCTION

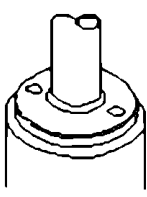

CURRENT PRODUCTION

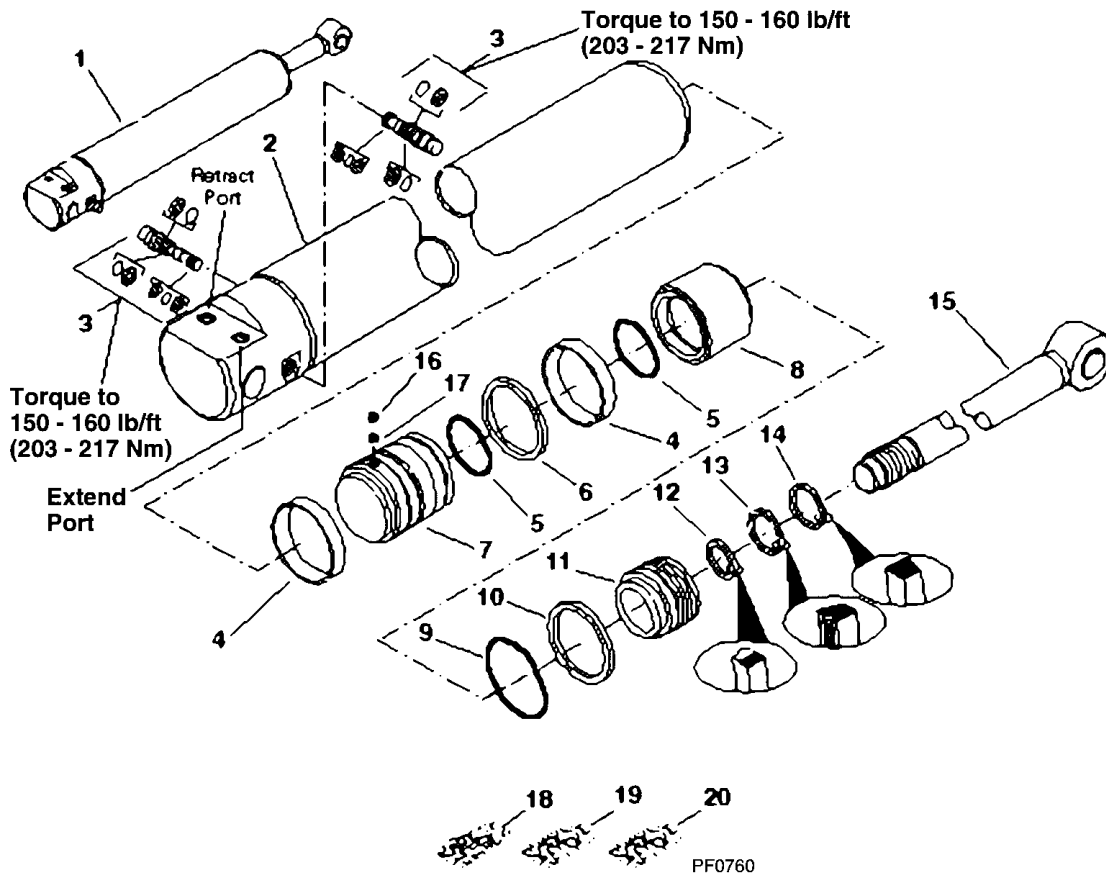

PH0342

SECTION 6 - HYDRAULIC COMPONENTS

FIGURE 6-4. BOOM EXTEND CYLINDER (EARLY PRODUCTION)

ITEM	PART NUMBER	QTY	DESCRIPTION	REV
1	NLA	1	Cylinder, Boom Extend (Includes Items 2 thru 17) (For Service, Order P/N 2716173)	
2	N.S.S.	1	Tube, Cylinder (Serviced Only in Boom Extend Cylinder Item 1)	
3	8902261	2	Valve, Counterbalance - preset to 3500 psi (See Kits)	
4	See Kits	2	Wear Ring	
5	See Kits	2	O-Ring	
6	See Kits	1	Seal, Piston	
7	8033734	1	Piston	
8	8033735	1	Tube, Stop	
9	See Kits	1	O-Ring	
10	See Kits	1	Ring, Backup	
11	8033732	1	Gland	
12	See Kits	1	Seal, Rod	
13	See Kits	1	Seal, Rod	
14	See Kits	1	Wiper	
15	8033733	1	Rod	
16	8033737	1	Screw, Set	
17	8033738	1	Screw, Cone Point Set	
		Ref	KITS	
18	8035513	1	Seal Kit, Services Both Early and Current Production Cylinders	
19	8205657	1	Seal Kit, Counterbalance Valve (Includes 3 O-Rings & 4 Backup Rings)	
20	8035247	1	Seal Kit, Gland Static Seal (Includes Items 5, 9 & 10)	

SECTION 6 - HYDRAULIC COMPONENTS

FIGURE 6-5. BOOM EXTEND CYLINDER (CURRENT PRODUCTION)

IMPORTANT:

There are two similar but distinctly different Boom Extend Cylinders. Make sure you know which version you have before ordering replacement parts. On "Early Production" cylinders, the gland is installed flush with the cylinder tube and has "TJB" stamped on the gland. On the "Current Production" cylinders, the gland has a lip that bottoms out against the cylinder tube.

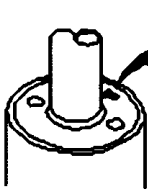

EARLY PRODUCTION

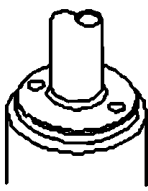

CURRENT PRODUCTION

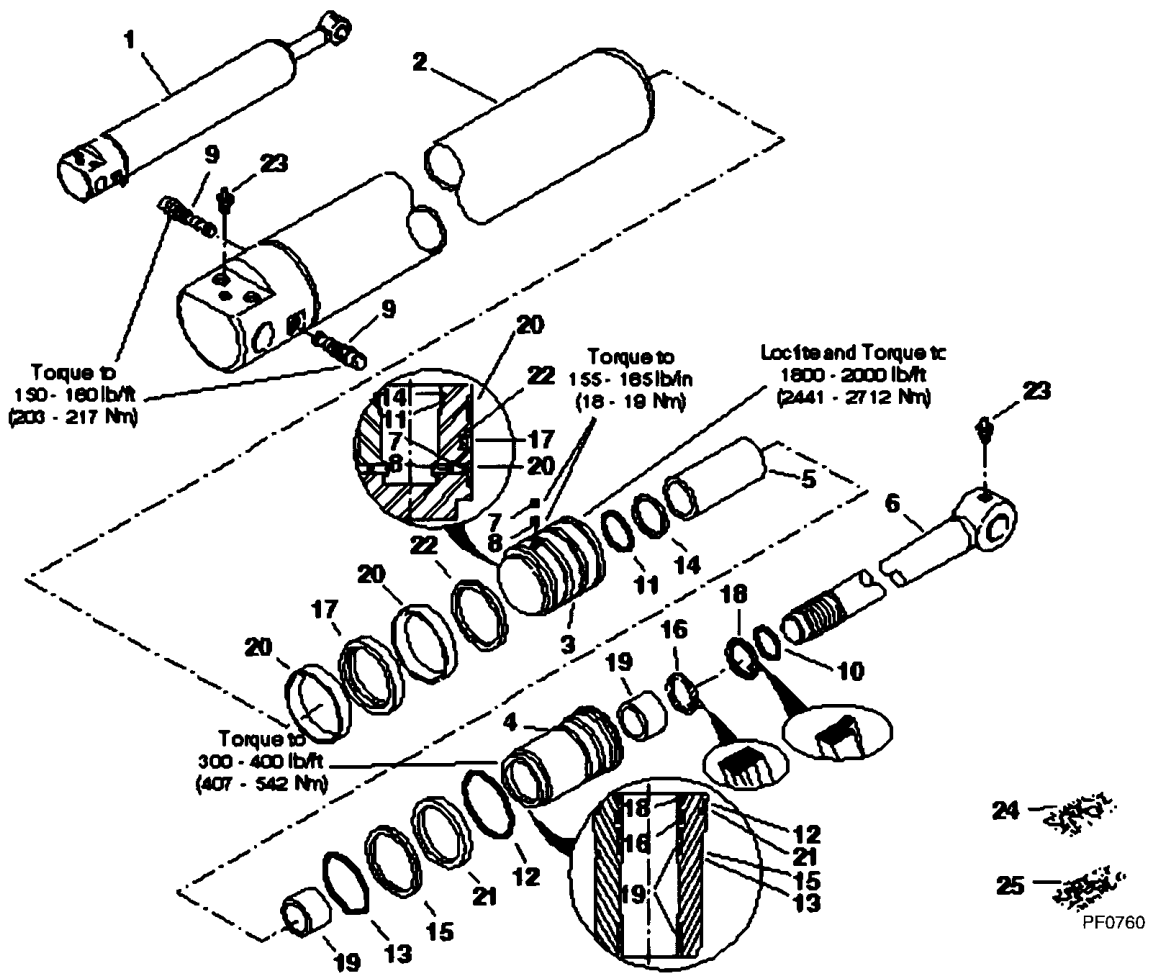

PH0342

SECTION 6 - HYDRAULIC COMPONENTS

FIGURE 6-5. BOOM EXTEND CYLINDER (CURRENT PRODUCTION)

ITEM	PART NUMBER	QTY	DESCRIPTION	REV
1	2716173	1	Cylinder, Boom Extend (Includes Items 2 thru 23)	
2	N.S.S.	1	Tube, Cylinder (Serviced Only in Boom Extend Cylinder Item 1)	
3	8035800	1	Piston	
4	8035539	1	Gland, Head	
5	8035616	1	Spacer, Rod	
6	8035615	1	Rod, Weldment	
7	8035536	1	Screw, Set 5/16-18 UNC x .50 Lg	
8	8035315	1	Screw, Set 5/16-18 UNC x .63 Lg	
9	8035514	2	Valve, Counterbalance - preset to 3500 psi	
10	See Kits	1	O-Ring	
11	See Kits	1	O-Ring	
12	See Kits	1	O-Ring	
13	See Kits	1	O-Ring	
14	See Kits	1	Ring, Backup	
15	See Kits	1	Ring, Backup	
16	See Kits	1	Seal, Rod	
17	See Kits	1	Seal, Piston	
18	See Kits	1	Wiper, HD Rod Sealed O.D.	
19	See Kits	2	Wearband	
20	See Kits	2	Wearband	
21	See Kits	2	Insert, Locking	
22	See Kits	1	Square Ring	
23	8520013	2	Grease Fitting	
		Ref	KITS	
24	8035513	1	Seal Kit, Services Both Early and Current Production Cylinders	
25	8205657	1	Seal Kit, Counterbalance Valve	

SECTION 6 - HYDRAULIC COMPONENTS

FIGURE 6-6. BOOM HOIST CYLINDER (Prior to SN 5819)

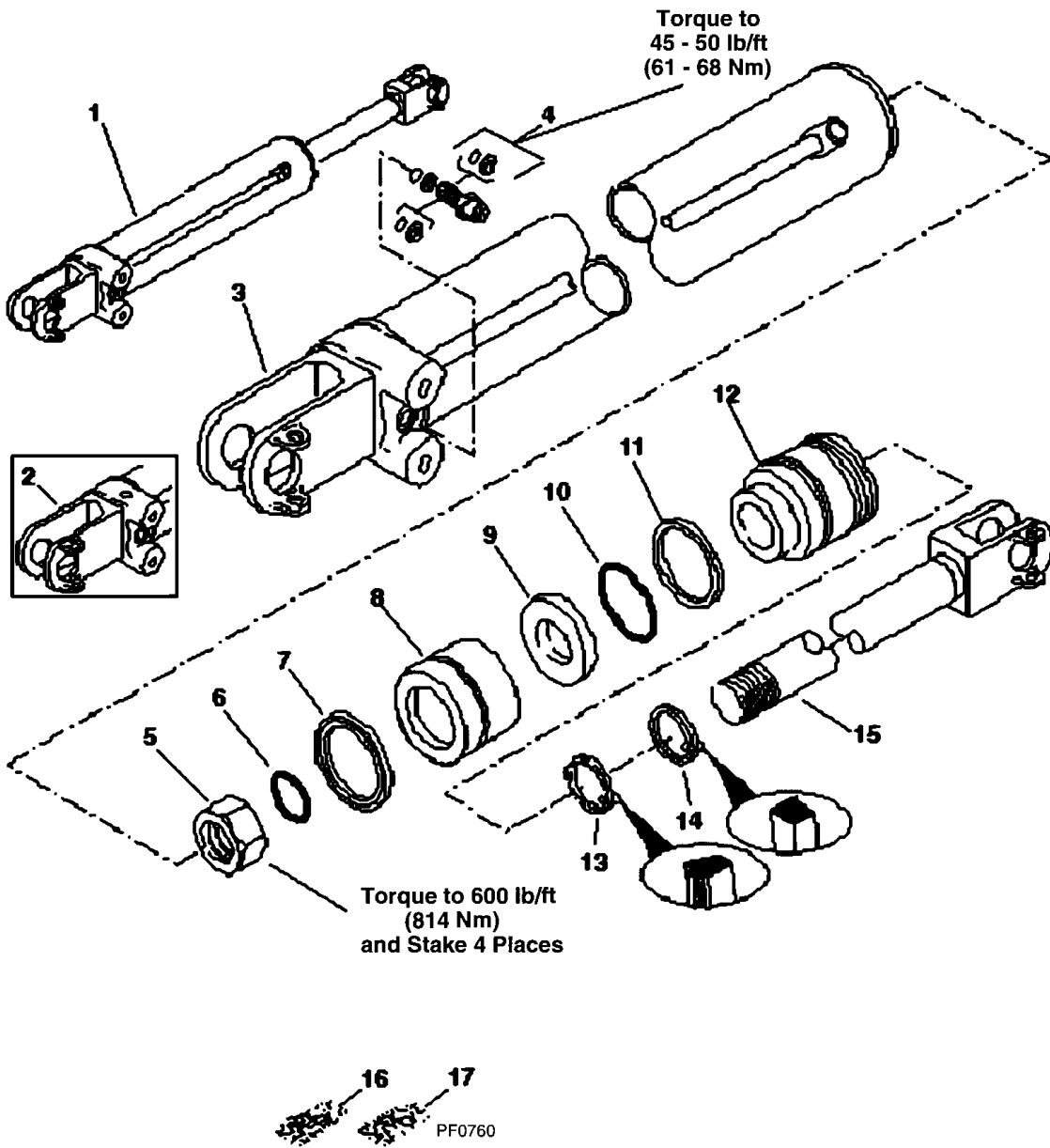

PH0231

SECTION 6 - HYDRAULIC COMPONENTS

FIGURE 6-6. BOOM HOIST CYLINDER (Prior to SN 5819)

ITEM	PART NUMBER	QTY	DESCRIPTION	REV
1	NLA	2	Cylinder, Boom Hoist (Includes Items 3 thru 15) (For Service, Order P/N 2714993)	
2	2713803	2	Cylinder, Boom Hoist w/Load Indicator Port (Includes Items 3 thru 15)	
		Ref	NOTE: Quantities Listed Below Are For 1 Cylinder Only	
3	N.S.S.	1	Tube, Cylinder (Serviced Only in Item 1)	
3	N.S.S.	1	Tube, Cylinder w/Load Indicator Port (Serviced Only in Item 2)	
4	8205726	1	Valve, Counterbalance - preset to 4000 psi (See Kits)	
5	8032714	1	Nut	
6	See Kits	1	O-Ring	
7	See Kits	1	Seal, Piston	
8	8033729	1	Piston	
9	8033730	1	Tube, Stop	
10	See Kits	1	O-Ring	
11	See Kits	1	Ring, Backup	
12	8033727	1	Gland	
13	See Kits	1	Seal, Rod	
14	See Kits	1	Wiper	
15	8033728	1	Rod	
		Ref	KITS	
16	8033731	1	Seal Kit, Boom Hoist Cylinder (Includes Items 6, 7, 10, 11, 13 & 14)	
17	8205656	1	Seal Kit, Counterbalance Valve (Includes 3 O-Rings & 3 Backup Rings)	

SECTION 6 - HYDRAULIC COMPONENTS

FIGURE 6-7. BOOM HOIST CYLINDER (SN 5819 through 13197)

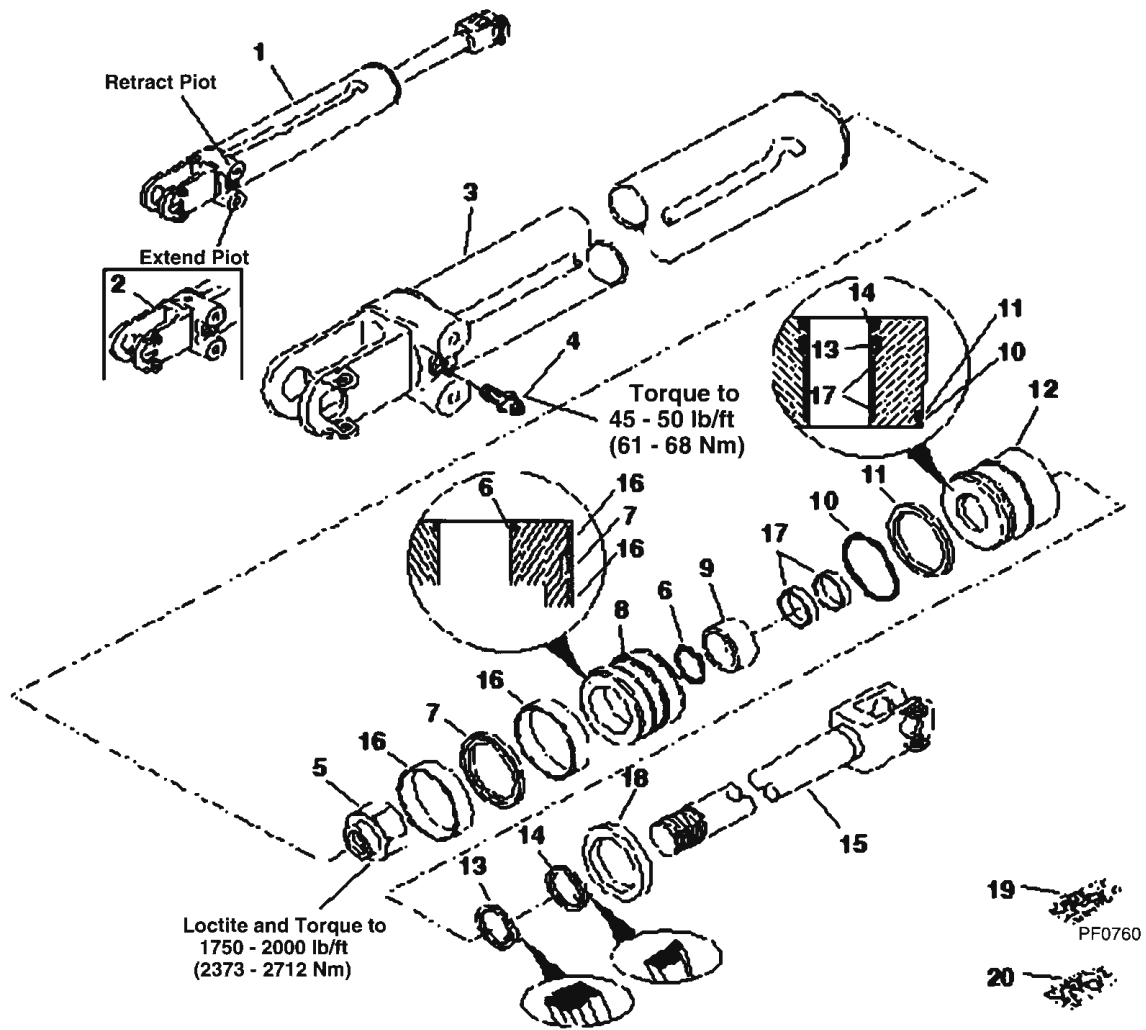

PH2010

SECTION 6 - HYDRAULIC COMPONENTS

FIGURE 6-7. BOOM HOIST CYLINDER (SN 5819 through 13197)

ITEM	PART NUMBER	QTY	DESCRIPTION	REV
1	2714993	2	Cylinder, Boom Hoist (Includes Items 3 thru 18)	
2	2713803	2	Cylinder, Boom Hoist w/Load Indicator Port (Includes Items 3 thru 18)	
		Ref	NOTE: Quantities Listed Below Are For 1 Cylinder Only	
3	N.S.S.	1	Tube, Cylinder (Serviced Only in Item 1)	
3	N.S.S.	1	Tube, Cylinder w/Load Indicator Port (Serviced Only in Item 2)	
4	8035542	1	Valve, Counterbalance - present 4000 psi (See Kits)	
5	8035308	1	Nut, Lock	
6	See Kits	1	O-Ring	
7	See Kits	1	Seal, Piston	
8	8035545	1	Piston	
9	8035608	1	Spacer, Rod	
10	See Kits	1	O-Ring	
11	See Kits	1	Ring, Backup	
12	8035609	1	Gland	
13	See Kits	1	Seal, Rod	
14	See Kits	1	Wiper	
15	8035607	1	Rod	
16	See Kits	2	Wearband	
17	See Kits	2	Wearband	
18	8035610	1	Collar, Locking	
		Ref	KITS	
19	8035386	1	Seal Kit, Boom Hoist Cylinder (Includes Items 6, 7, 10, 11, 13, 14, 16 & 17)	
20	8205656	1	Seal Kit, Counterbalance Valve (Includes 3 O-Rings & 3 Back-Up Rings)	

SECTION 6 - HYDRAULIC COMPONENTS

FIGURE 6-8. FRAME TILT CYLINDER

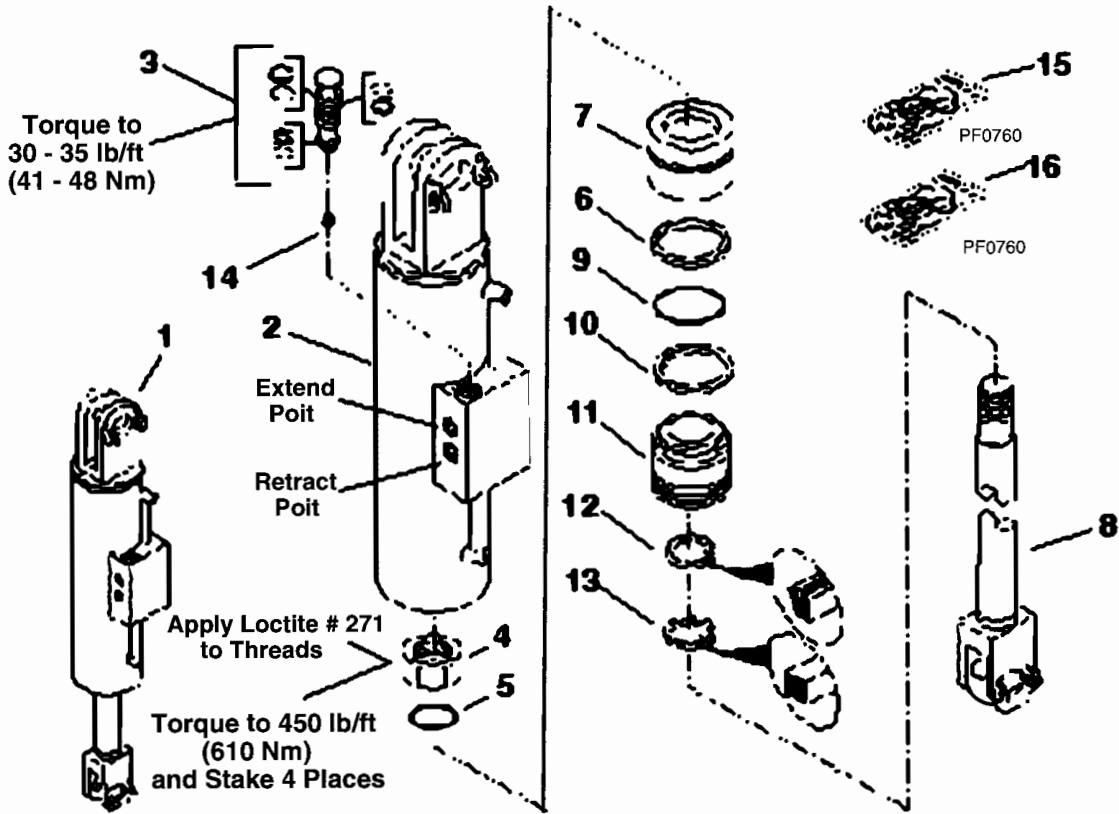

PH0362

SECTION 6 - HYDRAULIC COMPONENTS

FIGURE 6-8. FRAME TILT CYLINDER

ITEM	PART NUMBER	QTY	DESCRIPTION	REV
1	7115662	1	Cylinder, Frame Tilt (Includes Items 2 thru 14) (Prior to SN 0267)	
1	2713853	1	Cylinder, Frame Tilt (Includes Items 2 thru 13) (SN 0267 to Present)	
2	N.S.S.	1	Tube, Cylinder (Serviced Only in Item 1)	
3	8902511	2	Valve, Pilot Check (See Kits)	
4	8032726	1	Nut	
5	See Kits	1	O-Ring	
6	See Kits	1	Seal, Piston	
7	8033745	1	Piston	
8	8033744	1	Rod	
9	See Kits	1	O-Ring	
10	See Kits	1	Back-up Ring	
11	8032728	1	Gland	
12	See Kits	1	Seal, Rod	
13	See Kits	1	Wiper	
14	8033746	2	Orifice, .070 Dia (Prior to SN 0267)	
		Ref	KITS	
15	8033747	1	Seal Kit, Frame Tilt Cylinder (Includes Items 5, 6, 9, 10, 12 & 13)	
16	8205655	1	Seal Kit, Pilot Check Valve (Includes 3 O-Rings & 3 Back-Up Rings)	

SECTION 6 - HYDRAULIC COMPONENTS

FIGURE 6-9. STABILIZER CYLINDER

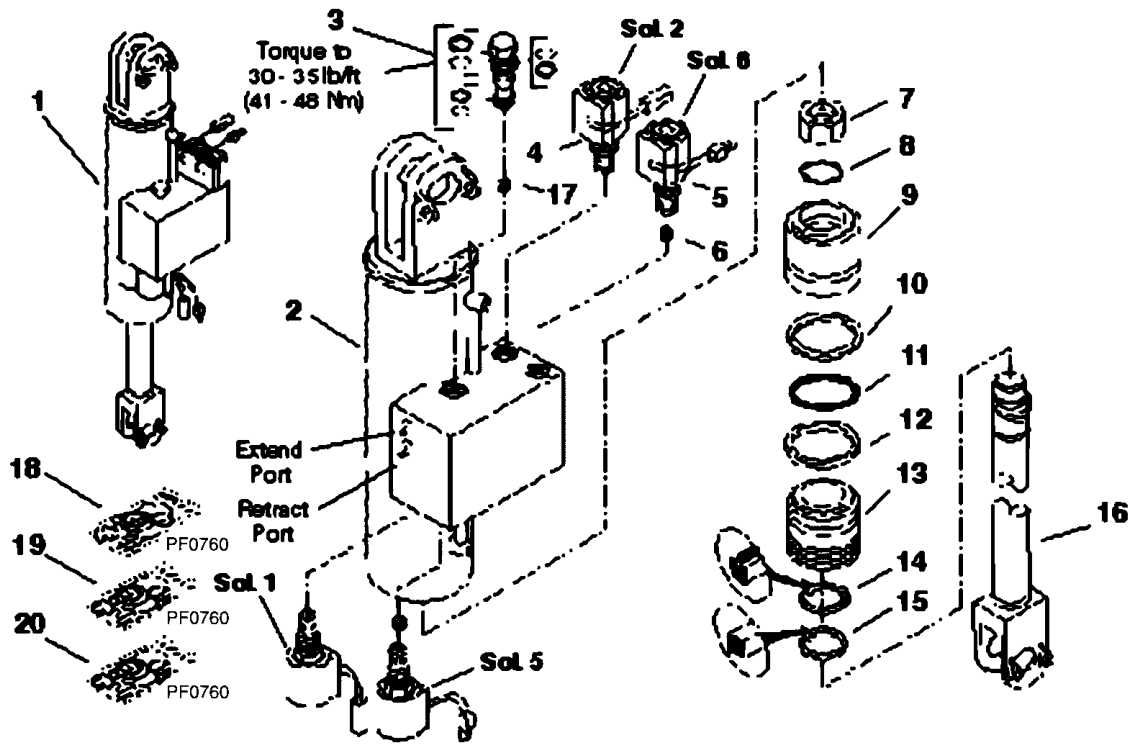

PH0351

SECTION 6 - HYDRAULIC COMPONENTS

FIGURE 6-9. STABILIZER CYLINDER

ITEM	PART NUMBER	QTY	DESCRIPTION	REV
1	2713333	1	Cylinder, Stabilizer (Includes Items 2 thru 17)	
2	N.S.S.	1	Tube, Cylinder (Serviced Only in Item 1)	
3	8902511	2	Valve, Pilot Check (See Kits)	
4	8033704	2	Solenoid Valve (See Kits)	
4	70023112	2	COIL	
4	80963058	2	Female Connector	
5	8033704	2	Solenoid Valve (See Kits)	
5	70023112	2	COIL	
6	8033715	2	Orifice, .060 Dia	
7	8032726	1	Nut	
8	See Kits	1	O-Ring	
9	8033745	1	Piston	
10	See Kits	1	Seal, Piston	
11	See Kits	1	O-Ring	
12	See Kits	1	Back-up Ring	
13	8032728	1	Gland	
14	See Kits	1	Seal, Rod	
15	See Kits	1	Wiper	
16	8033744	1	Rod	
17	8033721	2	Orifice, .029 Dia	
		Ref	KITS	
18	8033747	1	Seal Kit, Stabilizer Cylinder (Includes Items 8, 10 thru 12, 14 & 15)	
19	8205655	1	Seal Kit, Pilot Check Valve (Includes 3 O-Rings & 3 Back-Up Rings)	
20	8033756	1	Seal Kit, Solenoid Valve	

SECTION 6 - HYDRAULIC COMPONENTS

FIGURE 6-10. SLAVE CYLINDER (EARLY PRODUCTION)

IMPORTANT:

There are two similar but distinctly different Slave Cylinders. Make sure you know which version you have before ordering replacement parts. On 'Early Production' cylinders, the gland is installed flush with the cylinder tube and has "TJB" stamped on the gland. On the 'Current Production' cylinders, the gland has a tip that bottoms out against the cylinder tube.

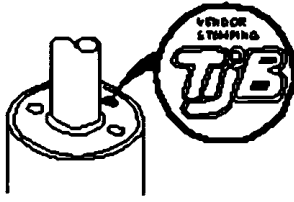

EARLY PRODUCTION

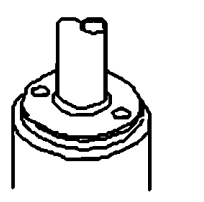

CURRENT PRODUCTION

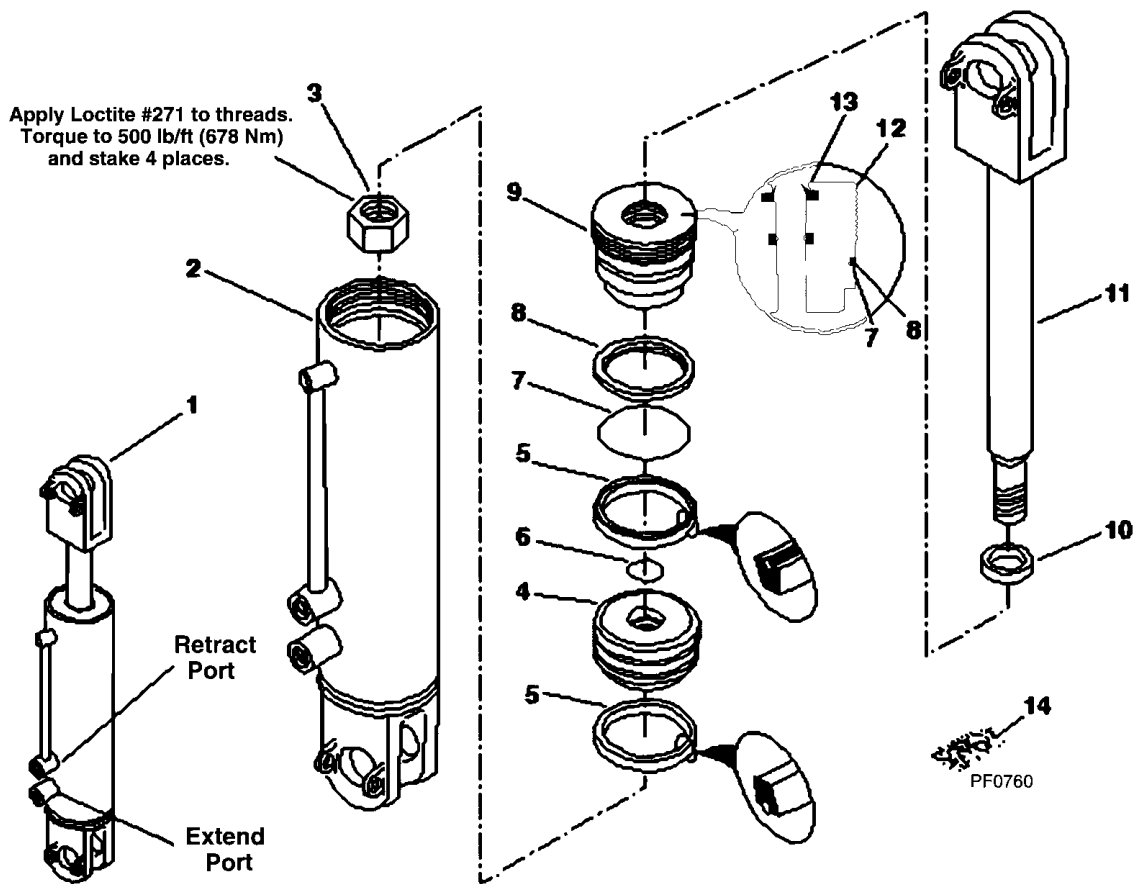

PH0372

SECTION 6 - HYDRAULIC COMPONENTS

FIGURE 6-10. SLAVE CYLINDER (EARLY PRODUCTION)

ITEM	PART NUMBER	QTY	DESCRIPTION	REV
1	2712983	NLA	Cylinder, Slave (includes Items 2 thru 13) (For Service, Order P/N 2714973)	
		Ref	NOTE: Quantities Listed Below Are For 1 Cylinder Only	
2	N.S.S.	1	Tube, Cylinder (Serviced Only in Item 1)	
3	8032726	1	Nut	
4	8033741	1	Piston	
5	See Kits	2	Seal, Piston	
6	See Kits	1	O-Ring	
7	See Kits	1	O-Ring	
8	See Kits	1	Ring, Backup	
9	8205506	1	Gland	
10	8033742	1	Washer, Thrust	
11	8033740	1	Rod	
12	See Kits	1	Seal, Rod	
13	See Kits	1	Wiper	
14	8205640	1	Seal Kit, Slave Cylinder (Includes Items 5 thru 8, 12 and 13)	

SECTION 6 - HYDRAULIC COMPONENTS

FIGURE 6-11. SLAVE CYLINDER (CURRENT PRODUCTION)

IMPORTANT:

There are two similar but distinctly different Slave Cylinders. Make sure you know which version you have before ordering replacement parts. On "Early Production" cylinders, the gland is installed flush with the cylinder tube and has "TJB" stamped on the gland. On the "Current Production" cylinders, the gland has a lip that bottoms out against the cylinder tube.

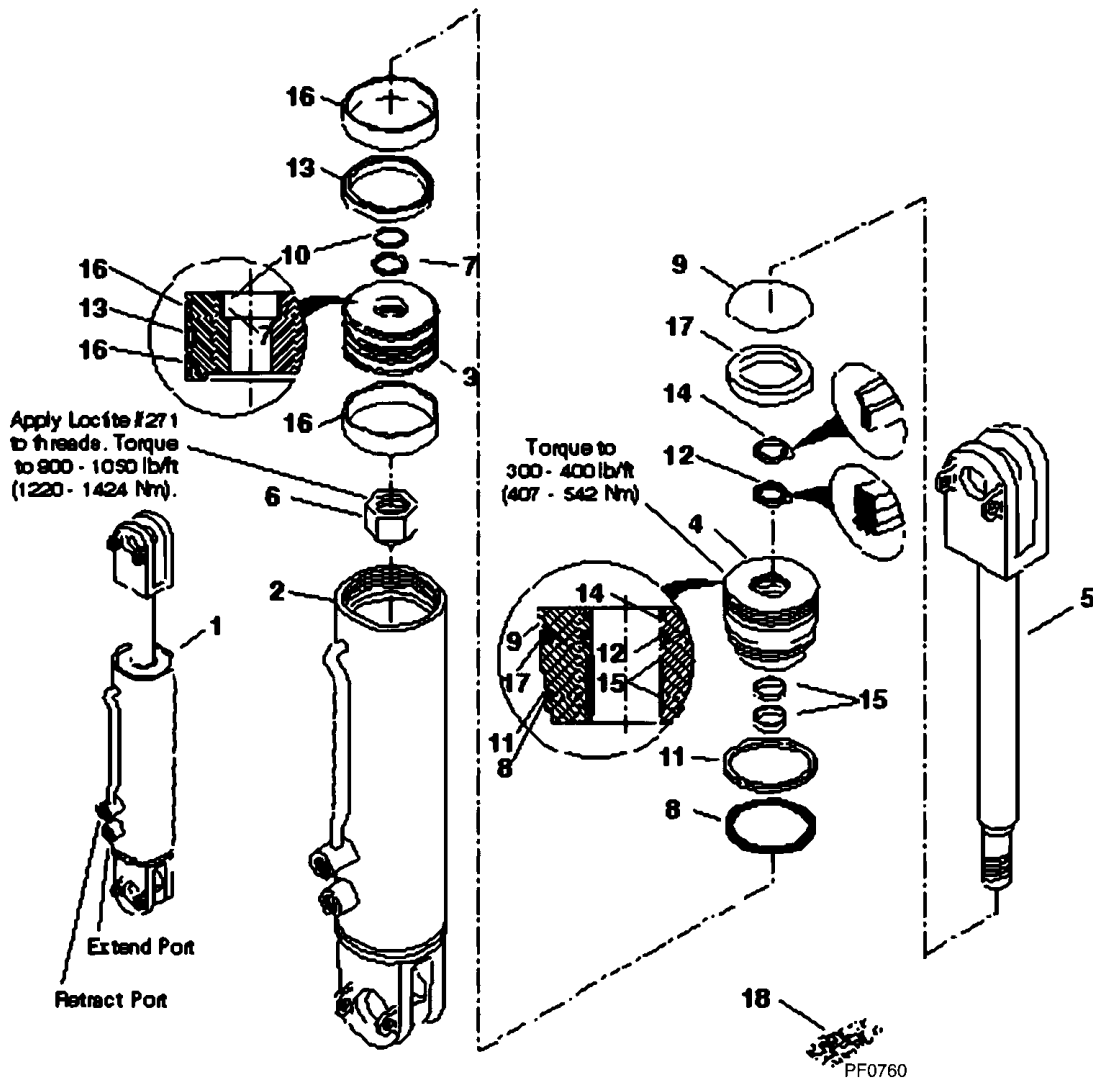

PH2020

SECTION 6 - HYDRAULIC COMPONENTS

FIGURE 6-11. SLAVE CYLINDER (CURRENT PRODUCTION)

ITEM	PART NUMBER	QTY	DESCRIPTION	REV
1	2714973	2	Cylinder, Slave (Includes Items 2 thru 17)	
		Ref	NOTE: Quantities Listed Below Are For 1 Cylinder Only	
2	8036001	1	CYLINDER TUBE	
3	8035613	1	Piston	
4	8035612	1	Gland, Head	
5	8035611	1	Rod	
6	8035547	1	Nut, Lock 1.375-12 UNF	
7	See Kits	1	O-Ring	
8	See Kits	1	O-Ring	
9	See Kits	1	O-Ring	
10	See Kits	2	Ring, Backup	
11	See Kits	1	Ring, Backup	
12	See Kits	1	Z-Seal, Deep	
13	See Kits	1	T-Seal, Capped	
14	See Kits	1	Wiper, HD Rod Sealed O.D.	
15	See Kits	2	Wearband	
16	See Kits	2	Wearband	
17	See Kits	2	Insert, Locking	
		Ref	KITS	
18	8034695	1	Seal Kit, Slave Cylinder (Includes Items 7 thru 17)	

SECTION 6 - HYDRAULIC COMPONENTS

FIGURE 6-12. ATTACHMENT TILT CYLINDER

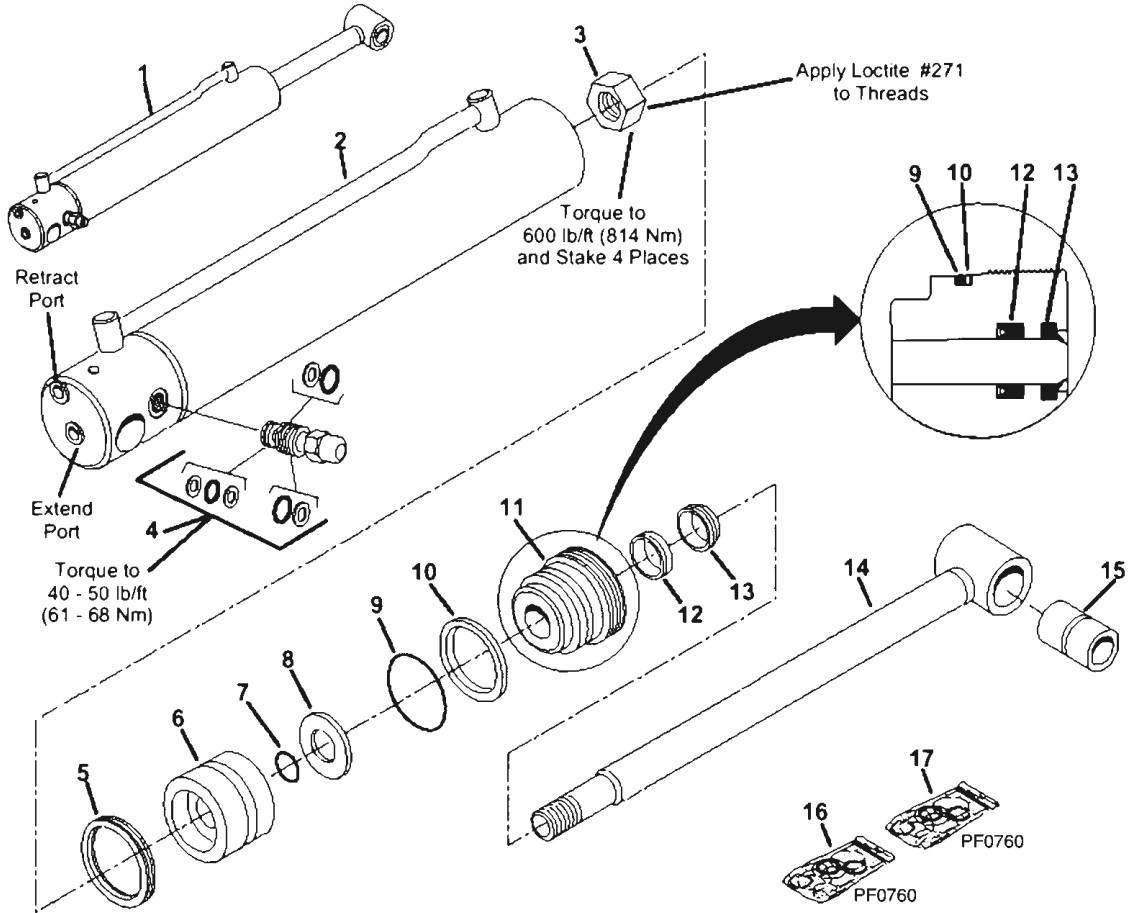

PH0221

SECTION 6 - HYDRAULIC COMPONENTS

FIGURE 6-12. ATTACHMENT TILT CYLINDER

ITEM	PART NUMBER	QTY	DESCRIPTION	REV
1	2712973	1	Cylinder, Attachment Tilt (Includes Items 2 thru 15)	
2	N.S.S.	1	Tube, Cylinder (Serviced Only in Item 1)	
3	8032714	1	Nut	
4	8902260	1	Valve, Counterbalance - preset to 4000 psi (See Kits)	
5	See Kits	1	Seal, Piston	
6	8033724	1	Piston	
7	See Kits	1	O-Ring	
8	8033725	1	Washer, Thrust	
9	See Kits	1	O-Ring	
10	See Kits	1	Back-up Ring	
11	8033722	1	Gland	
12	See Kits	1	Seal, Rod	
13	See Kits	1	Wiper	
14	8033723	1	Rod	
15	7089722	2	Bushing	
		Ref	KITS	
16	8035780	1	Seal Kit, Attachment Tilt Cylinder (Includes Items 5, 7, 9, 10, 12 & 13)	
17	8205656	1	Seal Kit, Counterbalance Valve (Includes 3 O-Rings & 4 Back-Up Rings)	

SECTION 6 - HYDRAULIC COMPONENTS

FIGURE 6-13. OUTRIGGER CYLINDER (Prior to SN 10882)

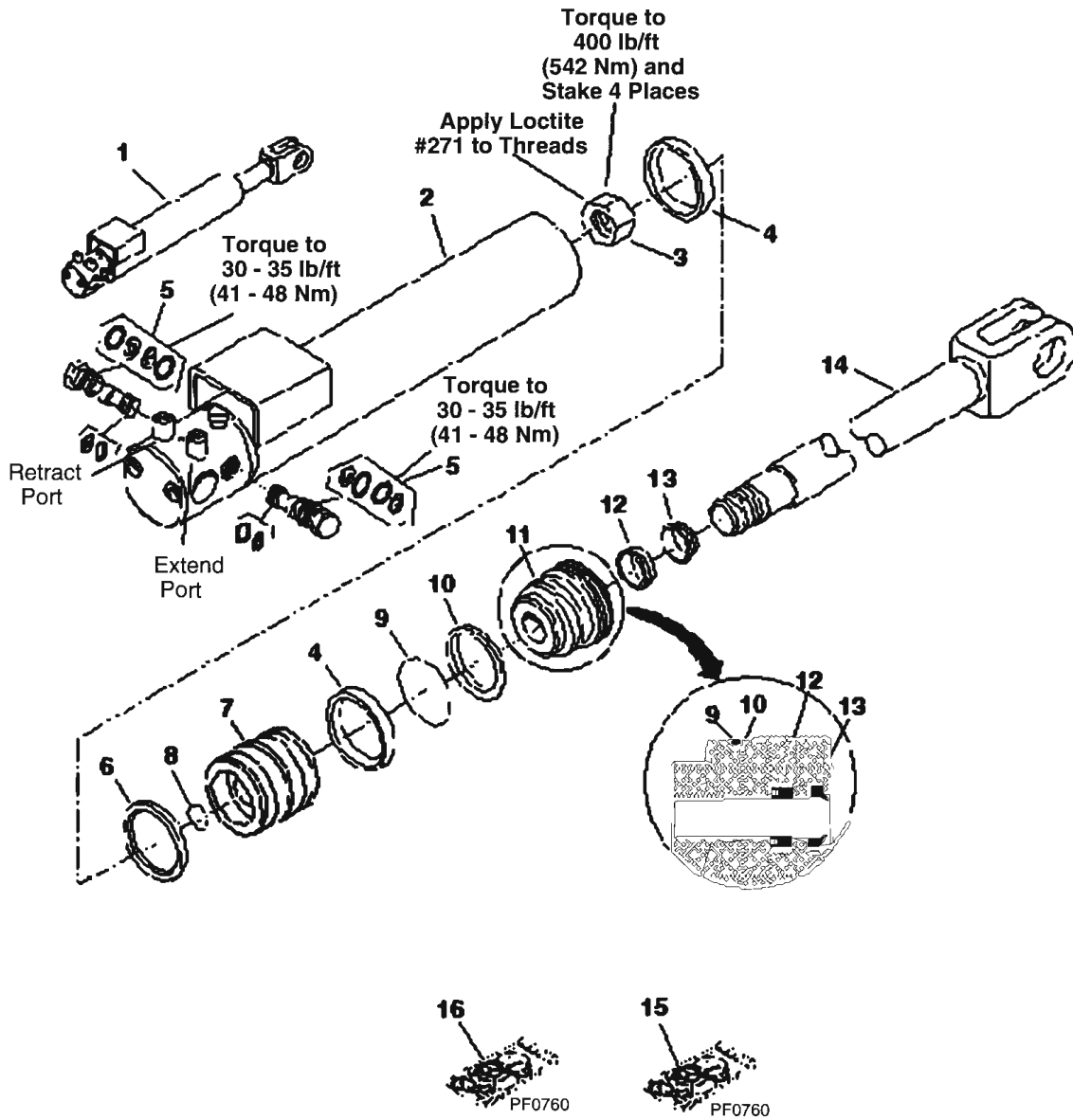

PH0382

SECTION 6 - HYDRAULIC COMPONENTS

FIGURE 6-13. OUTRIGGER CYLINDER (Prior to SN 10882)

ITEM	PART NUMBER	QTY	DESCRIPTION	REV
1	NLA	1	Cylinder, Outrigger (Includes Items 2 thru 14) (For Service, Order P/N 2716163)	
2	N.S.S.	1	Tube, Cylinder (Serviced Only in Item 1)	
3	8032702	1	Nut	
4	See Kits	2	Wear Ring	
5	8902511	2	Valve, Pilot Check (See Kits)	
6	See Kits	1	Seal, Piston	
7	8033750	1	Piston	
8	See Kits	1	O-Ring	
9	See Kits	1	O-Ring	
10	See Kits	1	Back-up Ring	
11	8033748	1	Gland	
12	See Kits	1	Seal, Rod	
13	See Kits	1	Wiper	
14	8033749	1	Rod	
		Ref	KITS	
15	8033751	1	Seal Kit, Outrigger Cylinder (Includes Items 4, 6, 8 thru 10, 12 & 13)	
16	8205655	1	Seal Kit, Pilot Check Valve (Includes 3 O-Rings & 3 Back-Up Rings)	

SECTION 6 - HYDRAULIC COMPONENTS

FIGURE 6-14. OUTRIGGER CYLINDER (SN 10882 through 13197)

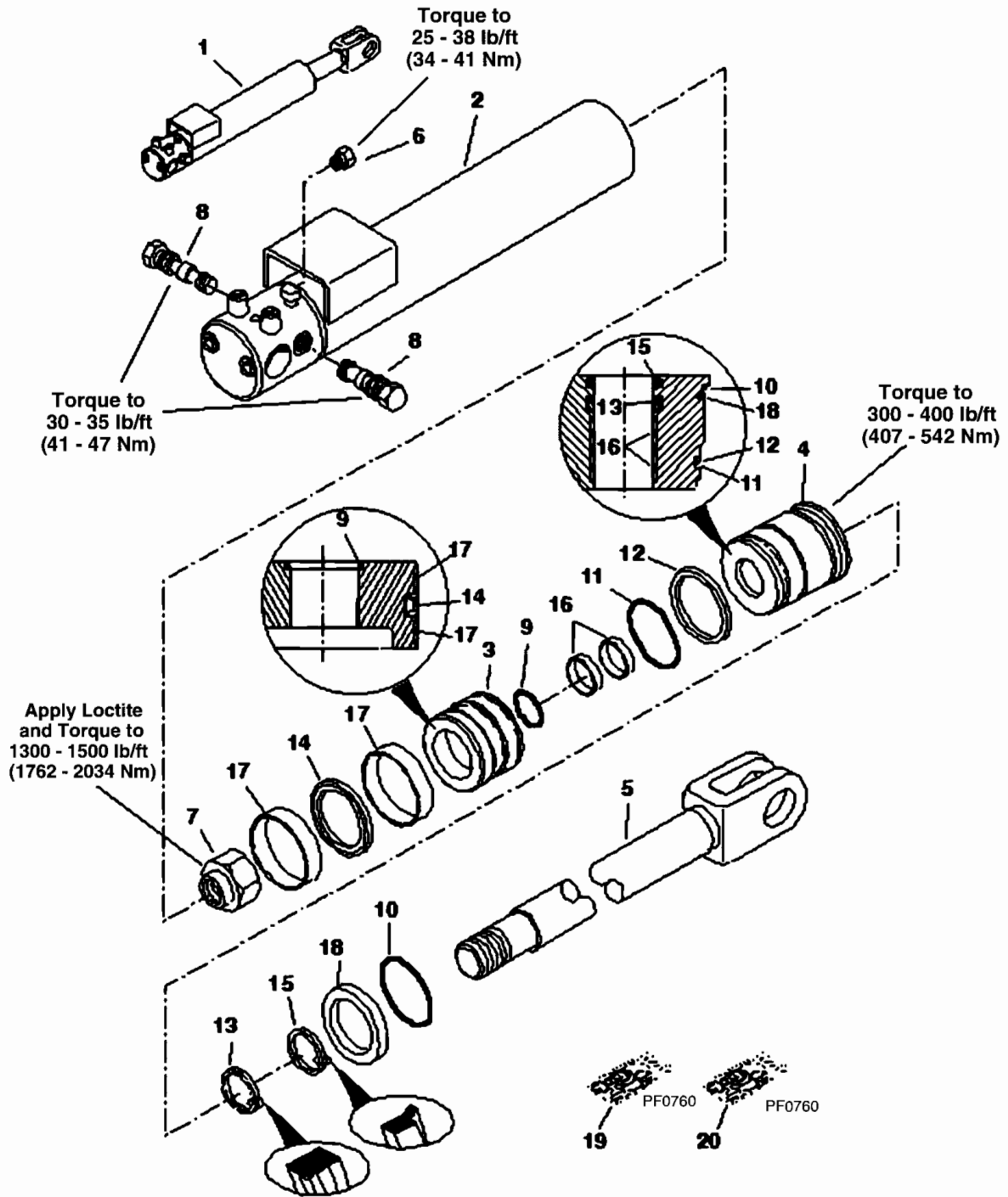

PH1260

SECTION 6 - HYDRAULIC COMPONENTS

FIGURE 6-14. OUTRIGGER CYLINDER (SN 10882 through 13197)

ITEM	PART NUMBER	QTY	DESCRIPTION	REV
1	2716163	1	Cylinder, Outrigger (Includes Items 2 thru 18)	
2	N.S.S.	1	Tube, Weldment (Serviced Only in Item 1)	
3	8035727	1	Piston	
4	8035728	1	Gland, Head	
5	8035729	1	Rod, Weldment	
6	8035730	1	Plug, SAE No. 4 Steel Hex Head	
7	8035322	1	Nut, Lock UNF 1.5-12	
8	8035731	2	Valve, PO Check, CKCB-XCN	
9	See Kits	1	O-Ring	
10	See Kits	1	O-Ring	
11	See Kits	1	O-Ring	
12	See Kits	1	Ring, Back-Up	
13	See Kits	1	Z-Seal, Deep w/Rod Back-Up	
14	See Kits	1	T-Seal, Capped	
15	See Kits	1	Wiper, Hd Rod - Sealed O.D.	
16	See Kits	2	Wearband, Precision	
17	See Kits	2	Wearband, Precision	
18	See Kits	2	Insert, Locking	
		Ref	KITS	
19	8035732	1	Seal Kit (Includes Items 9 thru 18)	
20	8035519	1	Seal Kit (Includes P/N 8035732 & P/N 8033751)	

SECTION 6 - HYDRAULIC COMPONENTS

FIGURE 6-15. SWING CARRIAGE CYLINDER

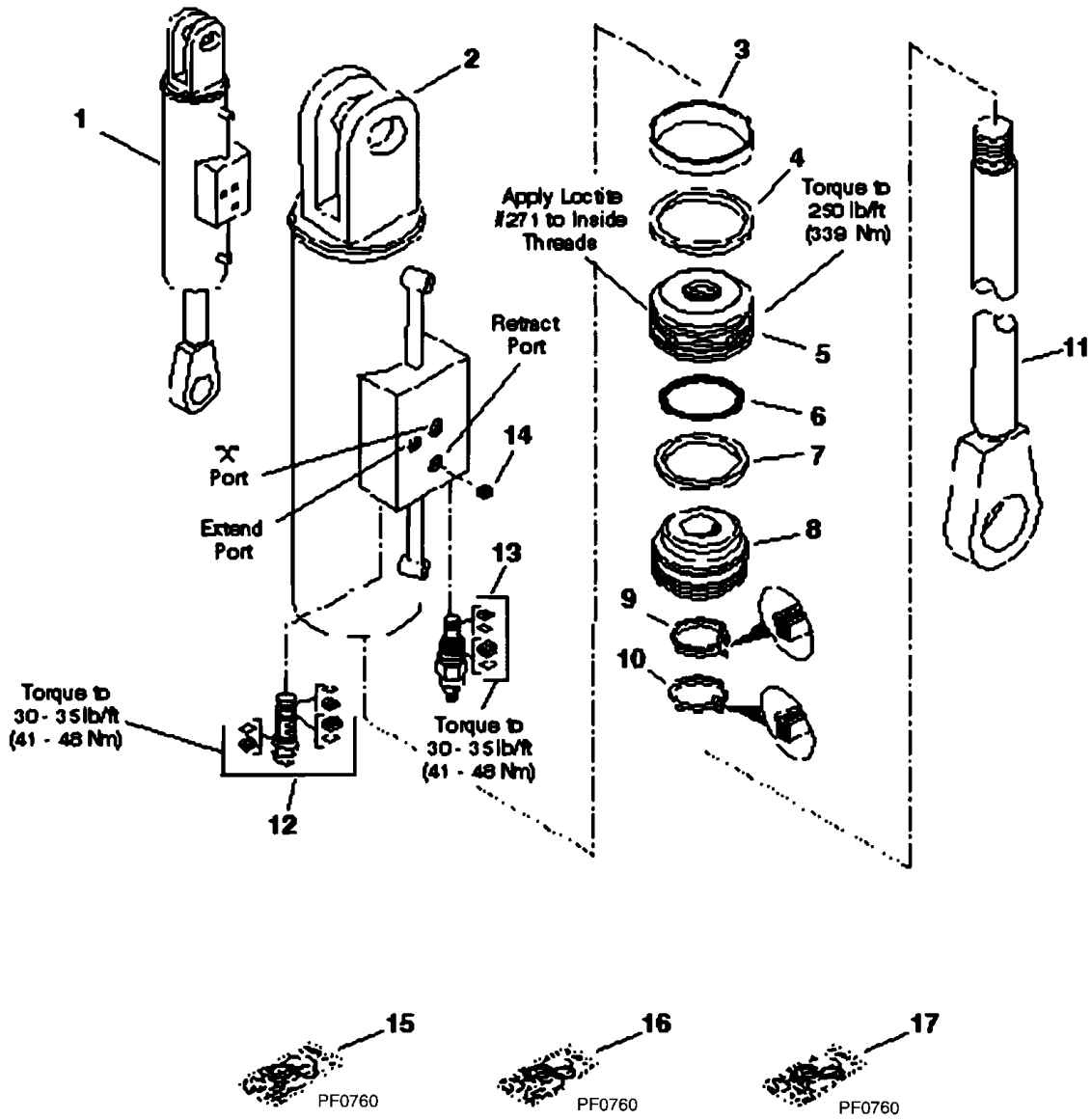

PH0441

SECTION 6 - HYDRAULIC COMPONENTS

FIGURE 6-15. SWING CARRIAGE CYLINDER

ITEM	PART NUMBER	QTY	DESCRIPTION	REV
1	2713363	1	Cylinder, Swing Carriage (Includes Items 2 thru 14)	
2	N.S.S.	1	Tube, Cylinder (Serviced Only in Item 1)	
3	See Kits	1	Wear Ring	
4	See Kits	1	Seal, Piston	
5	8033783	1	Piston	
6	See Kits	1	O-Ring	
7	See Kits	1	Back-up Ring	
8	8033784	1	Gland	
9	See Kits	1	Seal, Rod	
10	See Kits	1	Wiper	
11	8033785	1	Rod	
12	8033786	1	Valve, Counterbalance Cartridge - preset to 3000 psi (See Kits)	
13	70020428	1	RELIEF VALVE, (preset to 2000 psi)	
14	8033788	1	Orifice, .038 Dia	
		Ref	KITS	
15	8033789	1	Seal Kit, Swing Carriage Cylinder (Includes Items 3, 4, 6, 7, 9, & 10)	
16	8205655	1	Seal Kit, Valve Item 12 (Includes 3 O-Rings & 3 Back-Up Rings)	
17	7024574	1	Seal Kit, Valve Item 13	

SECTION 6 - HYDRAULIC COMPONENTS

FIGURE 6-16. SIDE TILT CARRIAGE CYLINDER

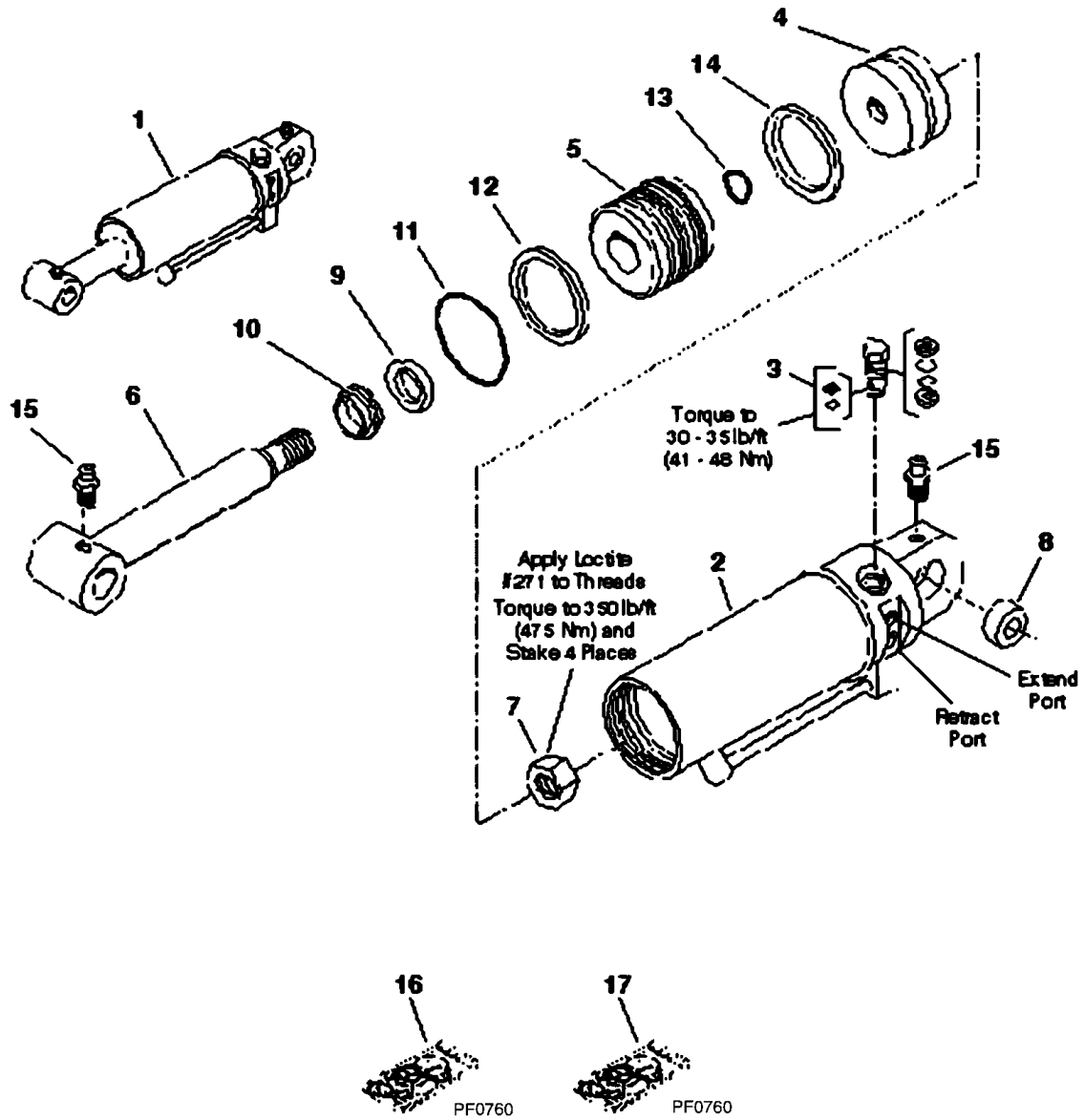

PH0800

SECTION 6 - HYDRAULIC COMPONENTS

FIGURE 6-16. SIDE TILT CARRIAGE CYLINDER

ITEM	PART NUMBER	QTY	DESCRIPTION	REV
1	2711613	1	Side Tilt Carriage Cylinder (Includes Items 2 thru 14)	
2	N.S.S.	1	Tube, Cylinder (Serviced Only in Item 1)	
3	8902511	2	Valve, Pilot Check (See Kits)	
4	8205545	1	Piston	
5	8205546	1	Gland	
6	8205547	1	Rod	
7	8205548	1	Nut, Piston	
8	8205514	1	Bearing, Self-Aligning	
9	See Kits	1	Seal, Rod	
10	See Kits	1	Wiper	
11	See Kits	1	O-Ring	
12	See Kits	1	Ring, Back-Up	
13	See Kits	1	O-Ring	
14	See Kits	1	Seal, Piston	
15	8520013	2	Fitting, Grease	
		Ref	KITS	
16	8205661	1	Seal Kit, Side Tilt Carriage Cylinder (Includes Items 9 thru 14)	
17	8205655	1	Seal Kit, Pilot Check Valve	

SECTION 6 - HYDRAULIC COMPONENTS

FIGURE 6-17. STEERING CYLINDER (Prior to SN 1168)

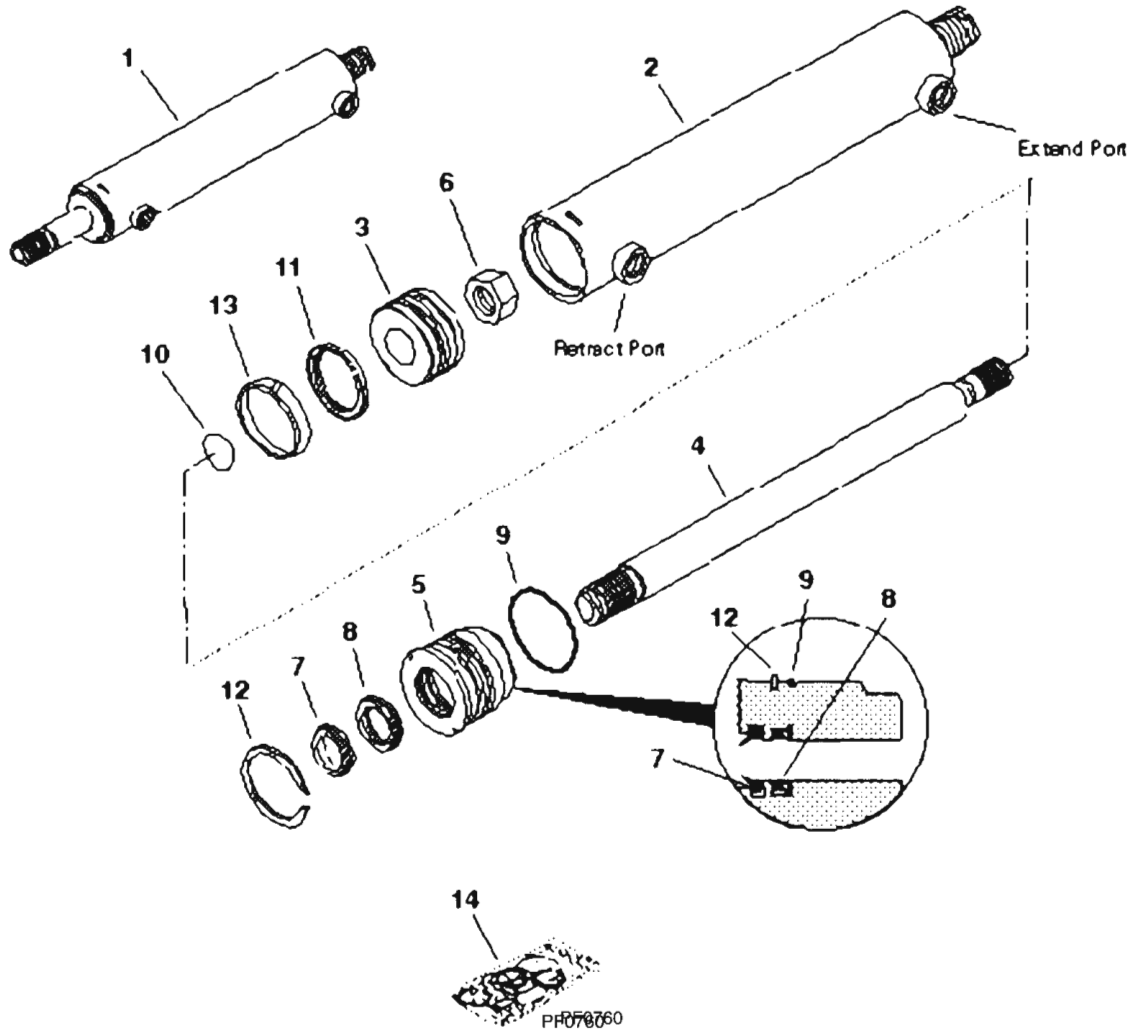

PH0621

SECTION 6 - HYDRAULIC COMPONENTS

FIGURE 6-17. STEERING CYLINDER (Prior to SN 1168)

ITEM	PART NUMBER	QTY	DESCRIPTION	REV
1	NLA	4	Steering Cylinder (Includes Items 2 thru 13) (For Service, Order P/N 8034684)	
		Ref	NOTE: Quantities Listed Below Are For 1 Cylinder Only	
	N.S.S.	1	Barrel Assembly (Serviced Only in Item 1)	
3	8033811	1	Piston	
4	8033812	1	Rod	
5	8033813	1	Gland	
6	8033814	1	Nut, Hex Lock	
7	See Kits	1	Wiper, Rod	
8	See Kits	1	Seal, Rod	
9	See Kits	1	O-Ring	
10	See Kits	1	O-Ring	
11	See Kits	1	Seal, Piston	
12	See Kits	1	Lock Ring	
13	See Kits	1	Wear Ring	
		Ref	KITS	
14	8033801	1	Seal Kit, Steering Cylinder (Includes Items 7 thru 13)	

SECTION 6 - HYDRAULIC COMPONENTS

FIGURE 6-18. STEERING CYLINDER (SN 1168 through 13197)

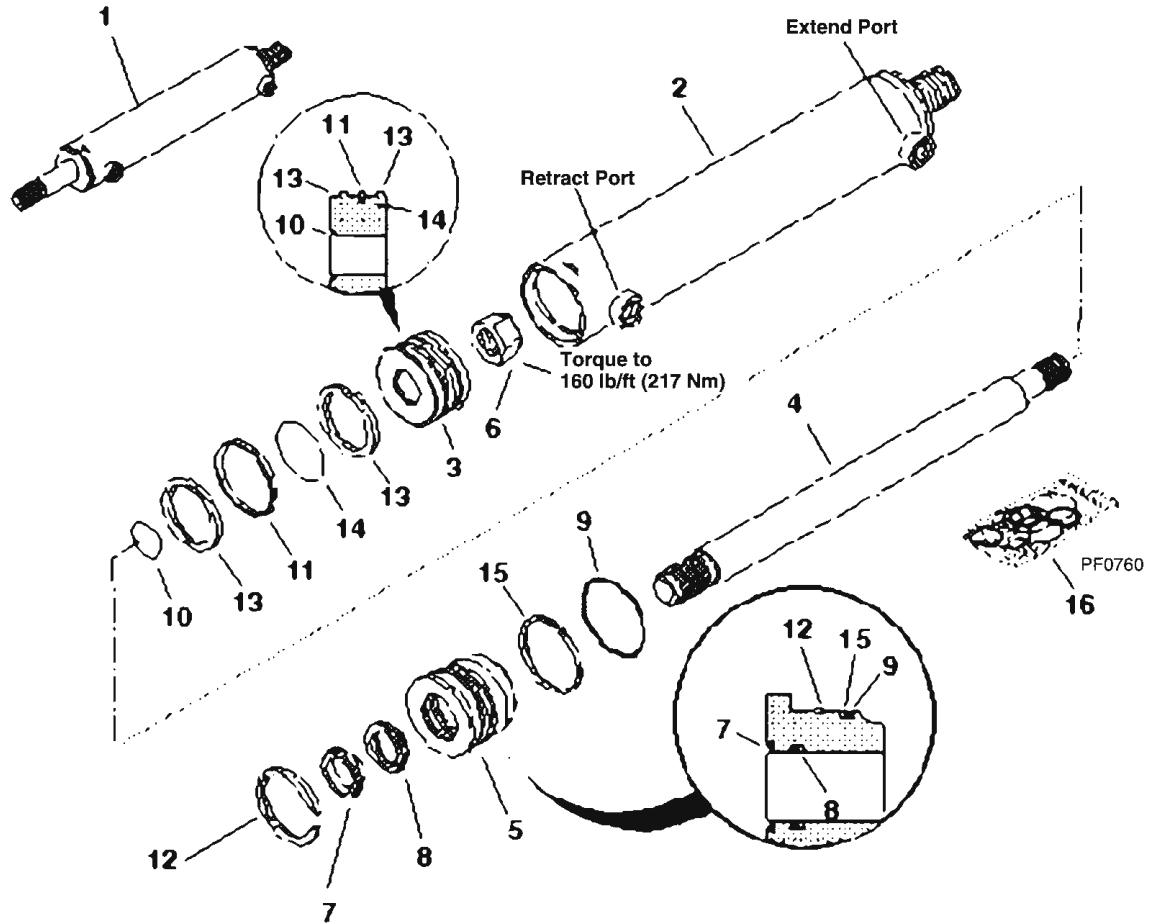

PH0900

SECTION 6 - HYDRAULIC COMPONENTS

FIGURE 6-18. STEERING CYLINDER (SN 1168 through 13197)

ITEM	PART NUMBER	QTY	DESCRIPTION	REV
1	8034684	4	Steering Cylinder (Includes Items 2 thru 15)	
		Ref	NOTE: Quantities Listed Below Are For 1 Cylinder Only	
	N.S.S.	1	Barrel Assembly (Serviced Only in Item 1)	
3	8034821	1	Piston	
4	8034822	1	Rod - 17.06in Long	
5	8034823	1	Gland	
6	8034824	1	Nut, Hex Lock	
7	See Kit	1	Wiper, Rod	
8	See Kit	1	Seal, U-Cup	
9	See Kit	1	O-Ring	
10	See Kit	1	O-Ring	
11	See Kit	1	Seal, Piston	
12	See Kit	1	Wire Retainer	
13	See Kit	2	Wear Ring	
14	See Kit	1	Expander	
15	See Kit	1	Back-up Ring	
		Ref	KITS	
16	8034691	1	Seal Kit, Steering Cylinder (Includes Items 7 thru 15)	

SECTION 6 - HYDRAULIC COMPONENTS

FIGURE 6-19. MAIN CONTROL VALVE

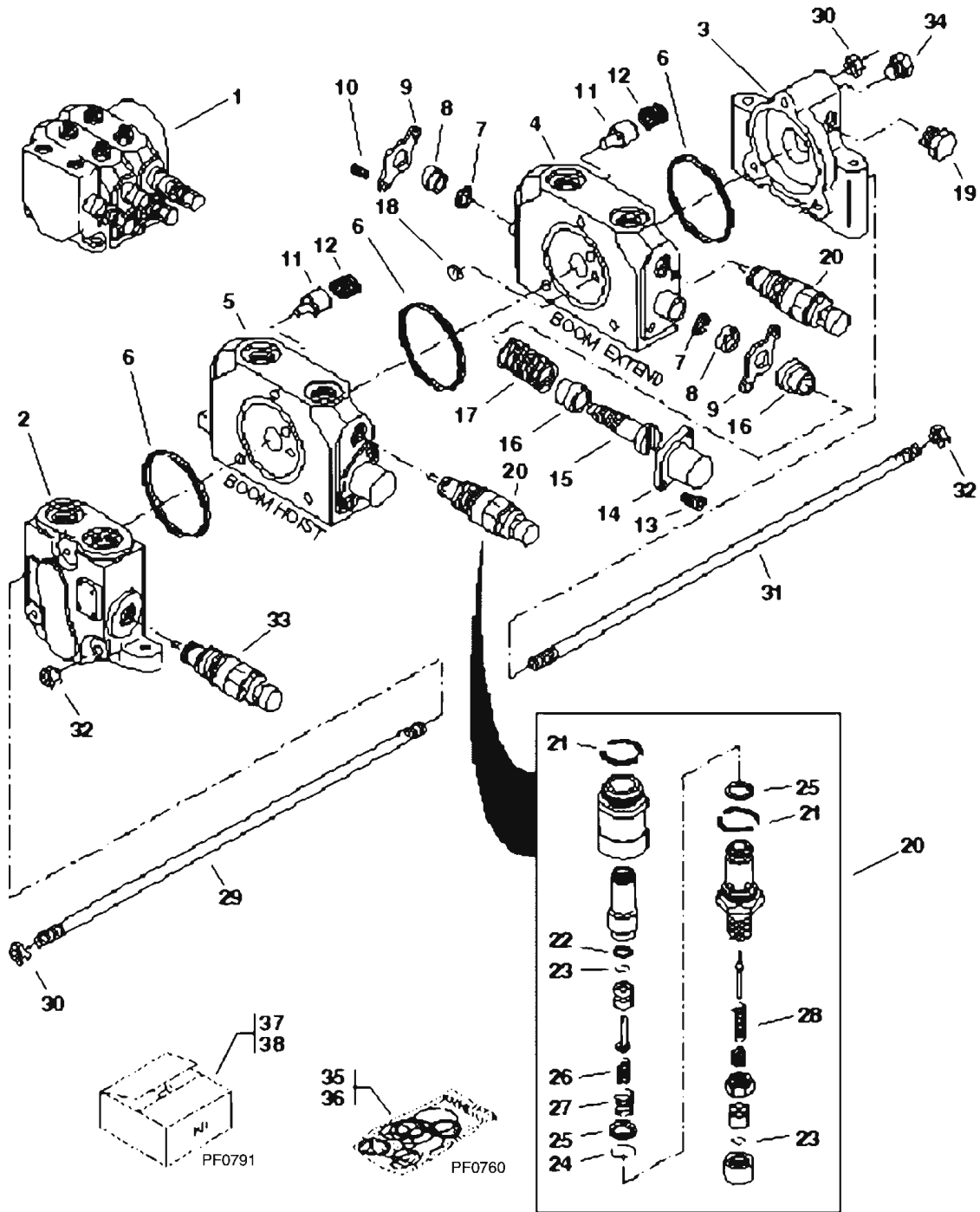

PH1250

SECTION 6 - HYDRAULIC COMPONENTS

FIGURE 6-19. MAIN CONTROL VALVE

ITEM	PART NUMBER	QTY	DESCRIPTION	REV
1	NLA	1	Main Control Valve, For Service, Order Kit P/N 7115652 (Prior to SN 0225)	
1	NLA	1	Main Control Valve, For Service, Order P/N 8902186 (SN 0225 through 8540)	
1	8902186	1	Main Control Valve (Includes Items 2 thru 34 (SN 8541 to Present))	
2	8034534	1	Section, Inlet (Includes 1 of Item 6)	
3	7130912	1	Kit, Outlet Section (Includes Inlet and Outlet Sections and Mounting Hardware) (Prior to SN 2200)	
3	8035267	1	Section - Outlet (SN 2200 to Present)	
4	8034552	1	Section, Boom Extend (Includes Items 6 thru 18)	
5	8034551	1	Section, Boom Hoist (Includes Items 6 thru 18)	
6	8034697	1	O-Ring (See Kits)	
7	See Kits	2	O-Ring	
8	See Kits	2	Wiper	
9	See Kits	2	Plate, Seal	
10	See Kits	2	Screw, Rd Hd Mach	
11	See Kits	1	Poppet, C.V.	
12	See Kits	1	Spring	
13	See Kits	2	HHCS	
14	See Kits	1	Cap, Spool	
15	See Kits	1	End, Spool	
16	See Kits	2	Seat, Spring	
17	See Kits	1	Spring	
18	See Kits	1	Shuttle	
19	8034539	1	Plug, Shut-off	
20	8034538	2	Relief Valve Assembly - Preset at 3200 50 psi (Includes Items 21 thru 28)	
21	See Kits	2	O-Ring	
22	See Kits	1	Ring, Back-Up	
23	See Kits	2	O-Ring	
24	See Kits	1	O-Ring	
25	See Kits	2	Ring, Back-Up	
26	See Kits	1	Spring	
27	See Kits	1	Spring	
28	See Kits	1	Spring	
29	See Kits	1	Tie Rod	
30	See Kits	2	Nut, Special	
31	See Kits	2	Tie Rod	
32	See Kits	4	Nut, Special	
33	8035387	1	Valve, Main Relief (Preset at 3500 50 psi)	
34	8760451	1	Plug, Hex Hd, SAE 6 - male str thd o-ring	
		Ref	KITS	
35	8034541	AR	Rebuild Kit for Items 4 & 5 (Includes 3 of Item 6 and listed quantities of Items 7 thru 18)	
36	8034540	1	Seal and Spring Kit for Relief Valve - Item 20	
37	8903011	1	Tie Rod Kit - 2 Section Valve (Includes Items 29 thru 32)	
38	7115652	1	Kit, Main Control Valve (Includes Valve and Instructions)	

SECTION 6 - HYDRAULIC COMPONENTS

FIGURE 6-20. SECONDARY CONTROL VALVE

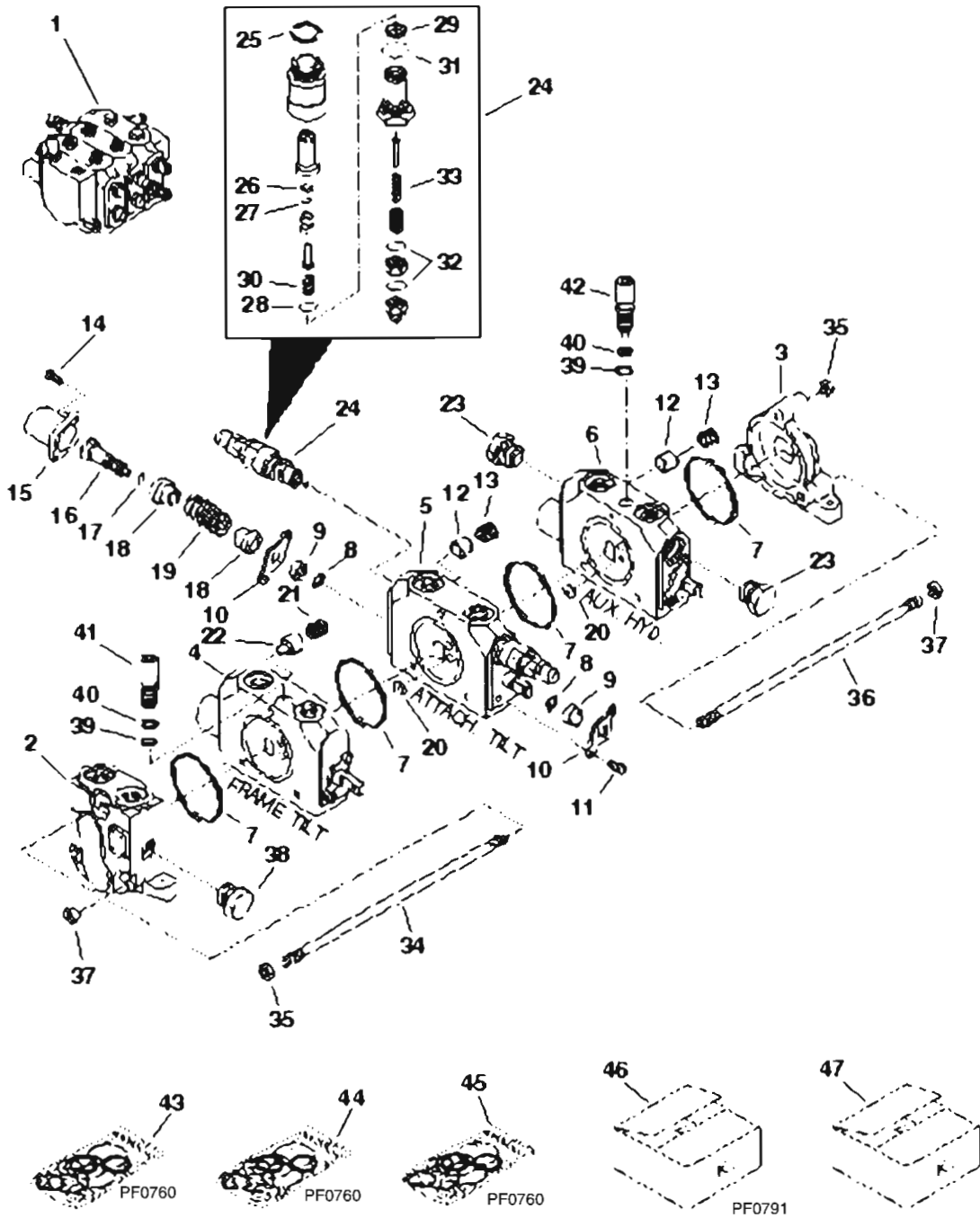

PH0472

SECTION 6 - HYDRAULIC COMPONENTS

FIGURE 6-20. SECONDARY CONTROL VALVE

ITEM	PART NUMBER	QTY	DESCRIPTION	REV
1	NLA	1	Secondary Control Valve, Frame Tilt, Attachment Tilt and Auxiliary Hydraulics, For Service, Order Kit P/N 7115712 (Prior to SN 0267)	
1	8902152	1	Secondary Control Valve, Frame Tilt, Attachment Tilt and Auxiliary Hydraulics (Includes Items 2 thru 42) (SN 0267 to Present)	
2	8034527	1	Section, Inlet (Includes 1 of Item 7)	
3	8034528	1	Section, Outlet	
4	8034549	1	Section, Frame Tilt (Includes Items 7 thru 11 & 14 thru 22)	
5	8034530	1	Section, Attachment Tilt (Includes Items 7 thru 20)	
6	8034531	1	Section, Auxiliary Hydraulics (Includes Items 7 thru 20)	
7	See Kits	1	O-Ring	
8	See Kits	2	O-Ring	
9	See Kits	2	Wiper	
10	See Kits	2	Plate, Seal	
11	See Kits	2	Screw, Rd Hd Mach	
12	See Kits	1	Poppet, C.V.	
13	See Kits	1	Spring	
14	See Kits	2	HHCS	
15	See Kits	1	Cap, Spool	
16	See Kits	1	End, Spool	
17	See Kits	1	O-Ring	
18	See Kits	2	Seat, Spring	
19	See Kits	1	Spring	
20	See Kits	2	Shuttle	
21	See Kits	1	Spring	
22	See Kits	1	Piston - Compensator, C.V.	
23	8902512	2	Plug, Shut-off	
24	8034532	2	Relief Valve Assembly - Preset at 3200 50 psi (Includes Items 25 thru 33)	
25	See Kits	1	O-Ring	
26	See Kits	1	Ring, Back-Up	
27	See Kits	1	O-Ring	
28	See Kits	1	O-Ring	
29	See Kits	1	Ring, Back-Up	
30	See Kits	1	Spring	
31	See Kits	1	O-Ring	
32	See Kits	2	O-Ring	
33	See Kits	1	Spring	
34	See Kits	1	Tie Rod	
35	See Kits	2	Nut, Special	
36	See Kits	2	Tie Rod	
37	See Kits	4	Nut, Special	
38	8760420	1	Plug, Hex Hd, SAE 10 - male str thd o-ring	
39	8034557	2	O-Ring	
40	8034556	2	Ring, Back-Up	
41	8034554	1	Screw, Flow Control	
42	8034555	1	Screw, Flow Control	
		Ref	KITS	
43	8034542	AR	Rebuild Kit for Items 5 & 6 (Includes 4 of Item 7 and listed quantities of Items 8 thru 20)	
44	8034550	1	Rebuild Kit for Item 4 (Includes 4 of Item 7 and listed quantities of Items 8 thru 11 & 14 thru 22)	

SECTION 6 - HYDRAULIC COMPONENTS

ITEM	PART NUMBER	QTY	DESCRIPTION	REV
45	10837948	1	Seal & Spring Kit for Relief Valve, Item 24	
46	8902095	1	Tie Rod Kit - 3 Section Valve (Includes Items 34 thru 37)	
47	7115712	1	Kit, Secondary Control Valve, Frame Tilt, Attachment Tilt and Auxiliary Hydraulics (Includes Valve and Instructions)	

SECTION 6 - HYDRAULIC COMPONENTS

FIGURE 6-21. DIRECTIONAL CONTROL VALVES 1 OF 2

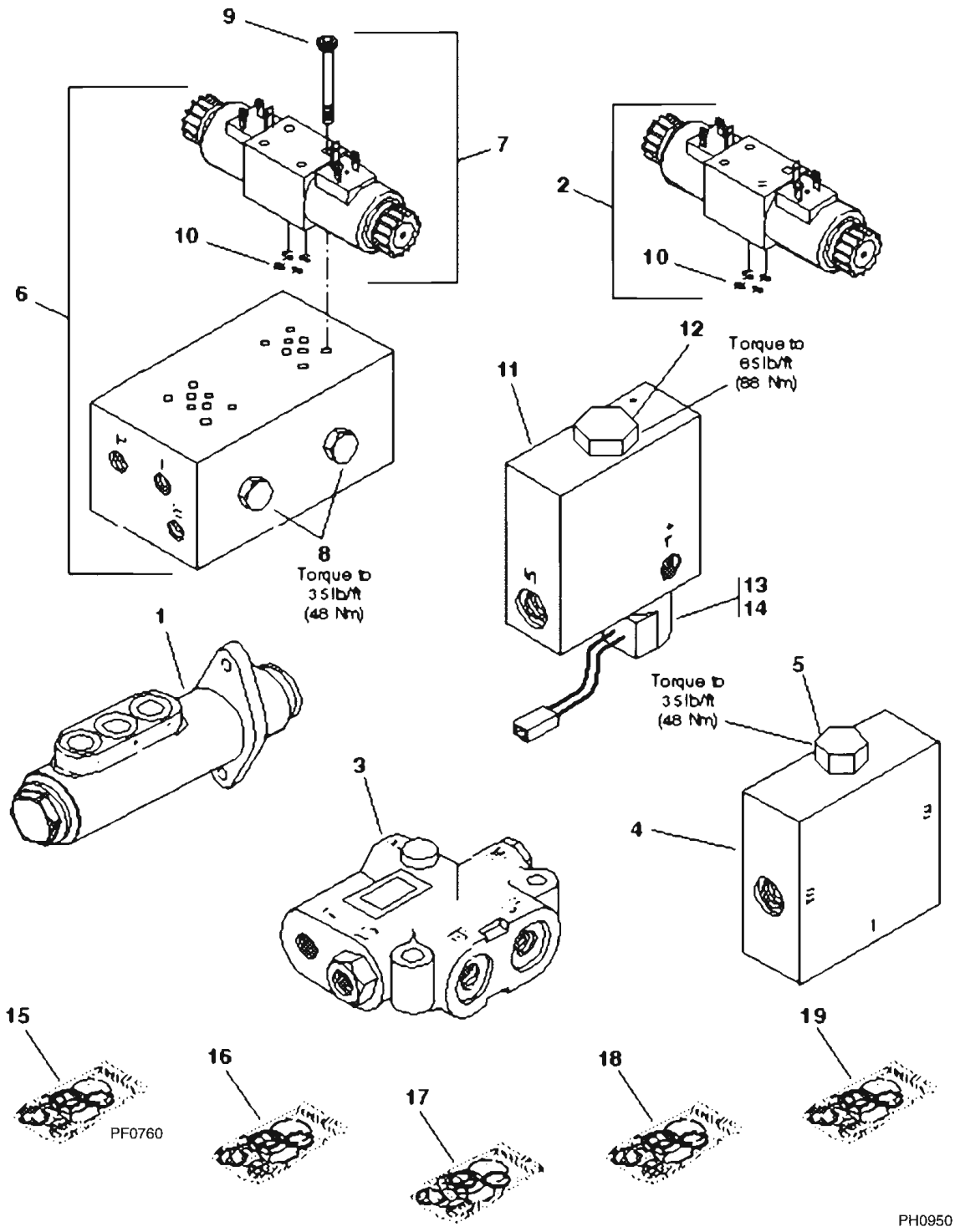

SECTION 6 - HYDRAULIC COMPONENTS

FIGURE 6-21. DIRECTIONAL CONTROL VALVES 1 OF 2

ITEM	PART NUMBER	QTY	DESCRIPTION	REV
1	NLA	1	Brake Valve, For Service, Order P/N 8902222 (Prior to SN 0654)	
1	7119813	1	Brake Valve Kit (SN 0654 through 1167)	
1	8902222	1	Brake Valve (SN 1168 to Present)	
2	8902137	1	Valve, Steer Select	
3	8904047	1	Valve, Priority	
4	8902838	1	Valve, Shuttle (Includes Item 5)	
5	8902846	1	Cartridge, Shuttle Valve (See Kits)	
6	8902141	1	Valve, Outrigger (Includes Items 7 & 8) (Prior to SN 10882)	
6	8902193	1	Valve, Outrigger (Includes Items 7 & 8) (SN 10882 to Present)	
7	8902140	2	Solenoid Valve Assembly	
8	8904049	2	Check Valve, Back to Back (See Kits)	
9	8304631	8	SHCS, #10-24 x 2in	
10	8640017	AR	O-Ring	
11	8902251	1	Valve, Boom Extend Lockout (Includes Items 12 thru 14)	
12	8034558	1	Cartridge, Poppet Type (See Kits)	
13	8034559	1	Stem, Coil (See Kits)	
14	8034560	1	Coil Assembly	
		Ref	KITS	
15	8033254	1	Repair Kit, Brake Valve (For Item 1)	
16	8205655	1	Seal Kit, Pressure Reducing Valve (For Item 5)	
17	8205655	1	Seal Kit, Check Valve, Back to Back (For Item 8)	
18	8034561	1	Seal Kit, Stem, Coil (For Item 13)	
19	8034562	1	Seal Kit, Cartridge, Poppet Type (For Item 12)	

SECTION 6 - HYDRAULIC COMPONENTS

FIGURE 6-22. DIRECTIONAL CONTROL VALVES 2 OF 2

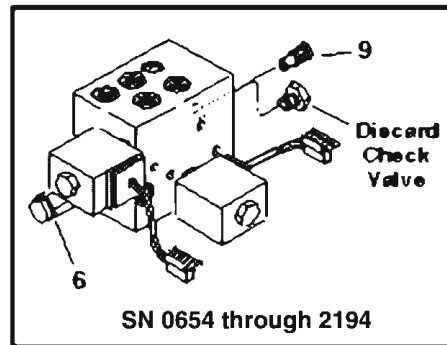
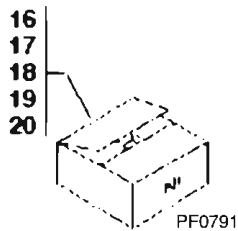
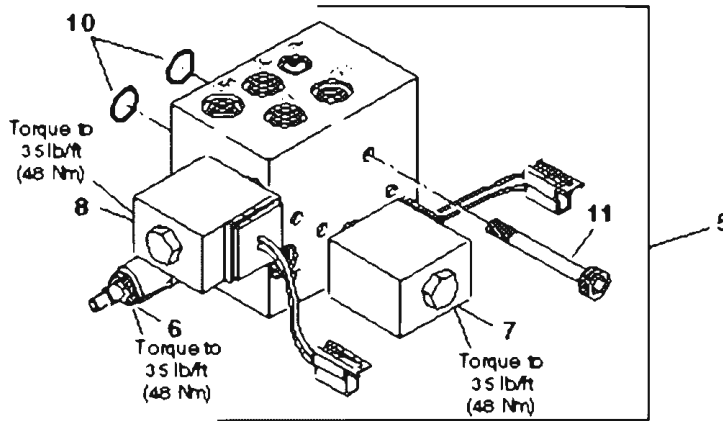
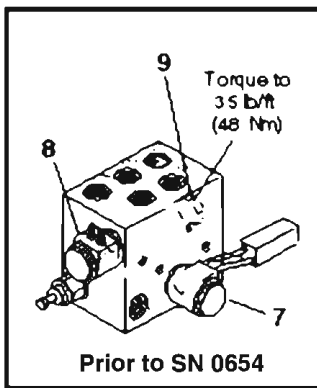
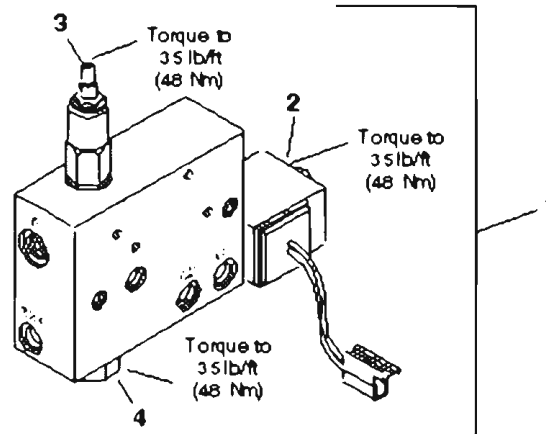
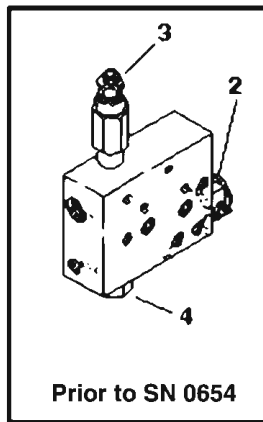

PH0960

SECTION 6 - HYDRAULIC COMPONENTS

FIGURE 6-22. DIRECTIONAL CONTROL VALVES 2 OF 2

ITEM	PART NUMBER	QTY	DESCRIPTION	REV
1	NLA	1	Valve, Pressure Reducing (Includes Items 2 thru 4)(See Kits Item 16 or 17) (Prior to SN 0654)	
1	8902266	1	Valve, Pressure Reducing (Includes Items 2 thru 4) (SN 0654 through 13199)	
2	8033760	1	Solenoid Valve (See Kits Item 12) (Prior to SN 0654)	
2	8036243	1	Solenoid Valve (See Kits Item 12) (SN 0654 through 13199)	
3	NLA	1	Cartridge, Pressure Reducing (See Kits Item 13) (Prior to SN 0654)	
3	8032993	1	Cartridge, Pressure Reducing (See Kits Item 13) (SN 0654 through 13199)	
4	8033769	1	Cartridge, Check Valve (See Kits Item 15) (Prior to SN 0654)	
4	8034577	1	Cartridge, Check Valve (See Kits Item 15) (SN 0654 through 13199)	
5	NLA	1	Valve, Axle Stabilizer (Includes Items 6 thru 11)(See Kits Item 18) (Prior to SN 0654)	
5	NLA	1	Valve, Axle Stabilizer (Includes Items 6 thru 11)(See Kits Item 19) (SN 0654 through 2194)	
5	8902267	1	Valve, Axle Stabilizer (Includes Items 6 thru 11) (SN 2195 through 13199)	
6	NLA	1	Pressure Reducing Valve - 60 psi (See Kits Item 20) (Prior to SN 0654)	
6	NLA	1	Pressure Reducing Valve - 60 psi (See Kits Item 19) (SN 0654 through 2194)	
6	8902688	1	Pressure Reducing Valve - 200 psi (See Kits Item 13) (SN 2195 through 13199)	
7	8033770	1	Solenoid Valve (See Kits Item 15) (Prior to SN 0654)	
7	8034578	1	Solenoid Valve (See Kits Item 15) (SN 0654 through 13199)	
8	8033760	1	Solenoid Valve (See Kits Item 12) (Prior to SN 0654)	
8	8034575	1	Solenoid Valve (See Kits Item 12) (SN 0654 through 13199)	
9	8033753	1	Check Valve (See Kits Item 15) (Prior to SN 0654)	
9	8902690	1	Plug (See Kits Item 15) (SN 0654 through 2194)	
10	8640019	2	O-Ring	
11	8310153	4	SHCS, 1/4-20 x 3in	
		Ref	KITS	
12	8033761	1	Seal Kit, Solenoid Valve (Prior to SN 0654)	
12	8034571	1	Seal Kit, Solenoid Valve (SN 0654 through 13199)	
13	8033768	1	Seal Kit, Pressure Reducing Cartridge (Prior to SN 0654)	
13	8034570	1	Seal Kit, Pressure Reducing Cartridge (SN 0654 through 13199)	
14	8205655	1	Seal Kit, Pressure Reducing Valve (Prior to SN 0654)	
14	8034570	1	Seal Kit, Pressure Reducing Valve (SN 0654 through 13199)	
15	8033763	1	Seal Kit, Check Valve (Prior to SN 0654)	
15	8034569	1	Seal Kit, Check Valve (SN 0654 through 13199)	
16	7117692	1	Rework Kit, Press Red Valve Models 8042 & 10042 (Prior to SN 0654)	
17	7117292	1	Rework Kit, Press Red Valve Model 10054 Only (Prior to SN 0654)	
18	7117282	1	Rework Kit, Stabilizer Valve (Prior to SN 0654)	
19	7130564	1	Rework Kit, Park Brake Valves (SN 0654 through 2194)	
20	7131274	1	Rework Kit, Park Brake Valves (Prior to SN 0654)	

SECTION 7 - ELECTRICAL

SECTION 7 - ELECTRICAL

FIGURE 7-1. ELECTRICAL SYSTEM - CAB HARNESS (Prior to SN 0292)

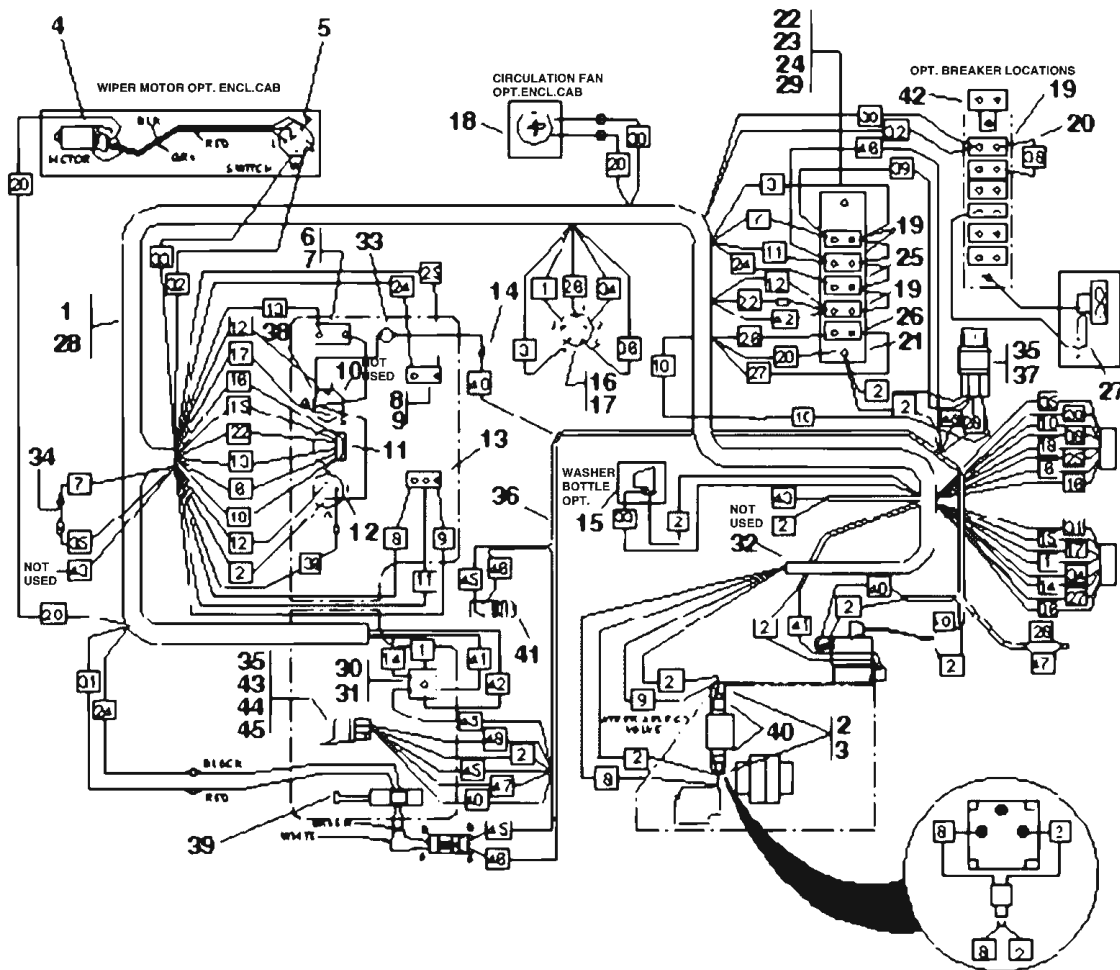

PH0601

SECTION 7 - ELECTRICAL

FIGURE 7-1. ELECTRICAL SYSTEM - CAB HARNESS (Prior to SN 0292)

ITEM	PART NUMBER	QTY	DESCRIPTION	REV
1	7114763	1	Harness, Cab (Includes Items 2 & 3)	
2	8220882	2	Connector, Solenoid (Includes Item 3)	
3	8688026	1	Seal, Connector (Not Shown)	
4	7112511	1	Motor Kit, Windshield Wiper	
5	8033201	1	Switch, Windshield Washer/ Wiper	
6	8223442	1	Switch, Test	
7	8580312	1	Boot, Test Switch	
8	8223405	1	Button, Horn	
9	8580311	1	Boot, Horn Button	
10	8464212	1	Gauge, Fuel	
11	8466305	1	Gauge, Warning Lights	
12	8467014	1	Hourmeter	
13	8223220	1	Switch, Steer Select	
14	8220050	1	Terminal - Male	
15	8033065	1	Washer Reservoir Assembly	
16	8223436	1	Switch, Ignition (w/Keys)	
17	8223438	1	Key, Ignition (Not Shown)	
18	8033078	1	Fan, Circulation	
19	8229215	3	Circuit Breaker, 6 amp (4 req'd on Closed Cab)	
20	7047041	1	Wire Assembly (Enclosed Cab Only)	
21	8229218	1	Bracket, Cricuit Breaker	
22	8305004	2	Nut, Hex, 1/4-20	
23	8307109	3	Washer, Flat 1/4in	
24	8307026	2	Washer, Lock, Int Tooth 3/8in	
25	8229216	1	Circuit Breaker, 10 amp	
26	8229226	1	Circuit Breaker, 40 amp	
27	8223024	1	Switch Kit, Heater	
28	8584001	AR	Wrap, Tie (Not Shown)	
29	8307002	2	Washer, Lock 1/4in	
30	8223444	1	Switch, Emergency Brake	
31	8223445	1	Guard, Switch	
32	8584003	1	Wrap, Tie	
33	8469028	1	Warning Light	
34	7112422	1	Wire Assembly	
35	8223517	2	Relay	
36	7115163	1	Harness, Stabilizer	
37	8305003	1	Nut, Hex #10-32	
38	8220008	1	Terminal, Ring #10	
39	8160621	1	Switch, Reverse	
40	8032756	2	Solenoid, Steer Select	
41	8223025	1	Switch, Brake	
42	8229232	1	Circuit Breaker 20 amp (optional)	
43	8303835	1	SHCS #10 x 1/2in	
44	8305002	1	Nut, Hex #10	
45	8307003	1	Washer, Lock #10	

SECTION 7 - ELECTRICAL

FIGURE 7-2. ELECTRICAL SYSTEM - CAB HARNESS (SN 0292 through 9908)

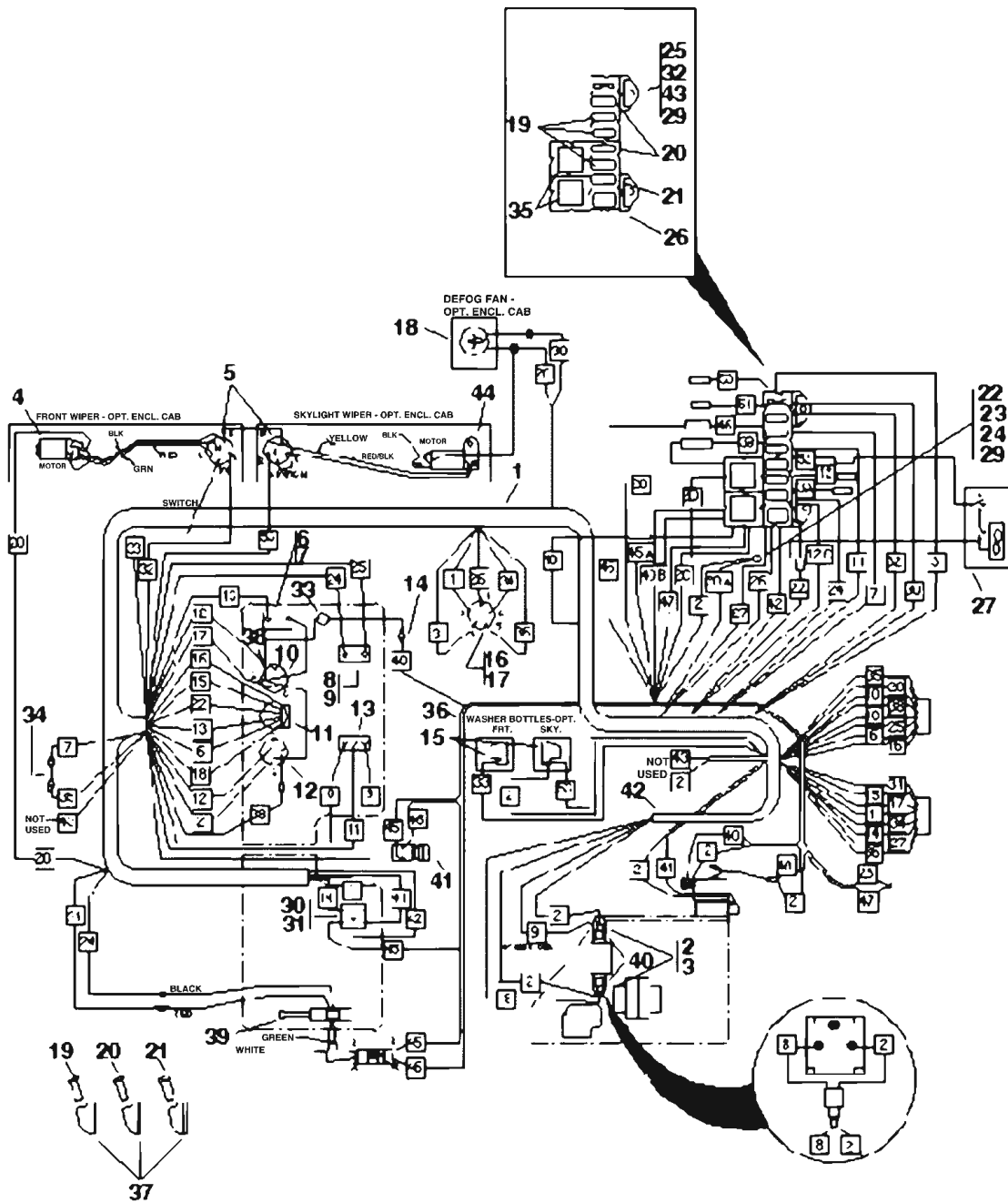

PH0701

SECTION 7 - ELECTRICAL

FIGURE 7-2. ELECTRICAL SYSTEM - CAB HARNESS (SN 0292 through 9908)

ITEM	PART NUMBER	QTY	DESCRIPTION	REV
1	7114754	1	Harness, Cab (Includes Items 2 & 3)	
2	8220882	2	Connector, Solenoid (Includes Item 3)	
3	8688026	1	Seal, Connector - Not Shown	
4	7112511	1	Motor Kit, Windshield Wiper	
5	8033201	2	Switch, Windshield Washer/Wiper	
6	8223442	1	Switch, Test	
7	8580312	1	Boot, Test Switch	
8	8223405	1	Button, Horn	
9	8580311	1	Boot, Horn Button	
10	8464212	1	Gauge, Fuel	
11	8466305	1	Gauge, Warning Lights	
12	8467014	1	Hourmeter	
13	8223220	1	Switch, Steer Select	
14	8220050	1	Terminal - Male	
15	8033065	1	Washer Reservoir Assembly	
16	8223436	1	Switch, Ignition (w/Keys)	
17	8223438	1	Key, Ignition (Not Shown)	
18	8033078	1	Fan, Defrost	
19	8229233	2	Fuse, 7.5 amp (3 required on Closed Cab)	
20	8229234	2	Fuse, 10 amp (3 required on Closed Cab)	
21	8229235	1	Fuse, 20 amp (Opt. Light Package)	
22	8305004	1	Nut, Hex, 1/4-20	
23	8307109	2	Washer, Flat 1/4in	
24	8307026	2	Washer, Lock, Int Tooth 3/8in	
25	8305002	4	Nut, Hex #10	
26	8229238	2	Fuse, 40 Amps	
27	8223024	1	Switch Kit, Heater	
28	8584001	AR	Wrap, Tie (Not Shown)	
29	8307106	3	Washer, Flat 5/16in LT	
30	8223444	1	Switch, Emergency Brake	
31	8223445	1	Guard, Switch	
32	8307003	4	Washer, Lock #10	
33	8469028	1	Warning Light	
34	7112422	1	Wire Assembly	
35	8225117	2	Relay	
36	7114604	1	Harness, Stabilizer	
37	8582007	3	Clip, Spare Fuse	
38	8220008	1	Terminal, Ring #10	
39	8160621	1	Switch, Reverse	
40	8032756	2	Solenoid, Steer Select	
41	8223025	1	Switch, Brake	
42	8584003	1	Wrap, Tie (Not Shown)	
43	8307111	4	Washer, Flat #10	
44	8034810	1	Skylight Wiper Motor	

SECTION 7 - ELECTRICAL

FIGURE 7-3. ELECTRICAL SYSTEM - CAB HARNESS (SN 9909 through 13197)

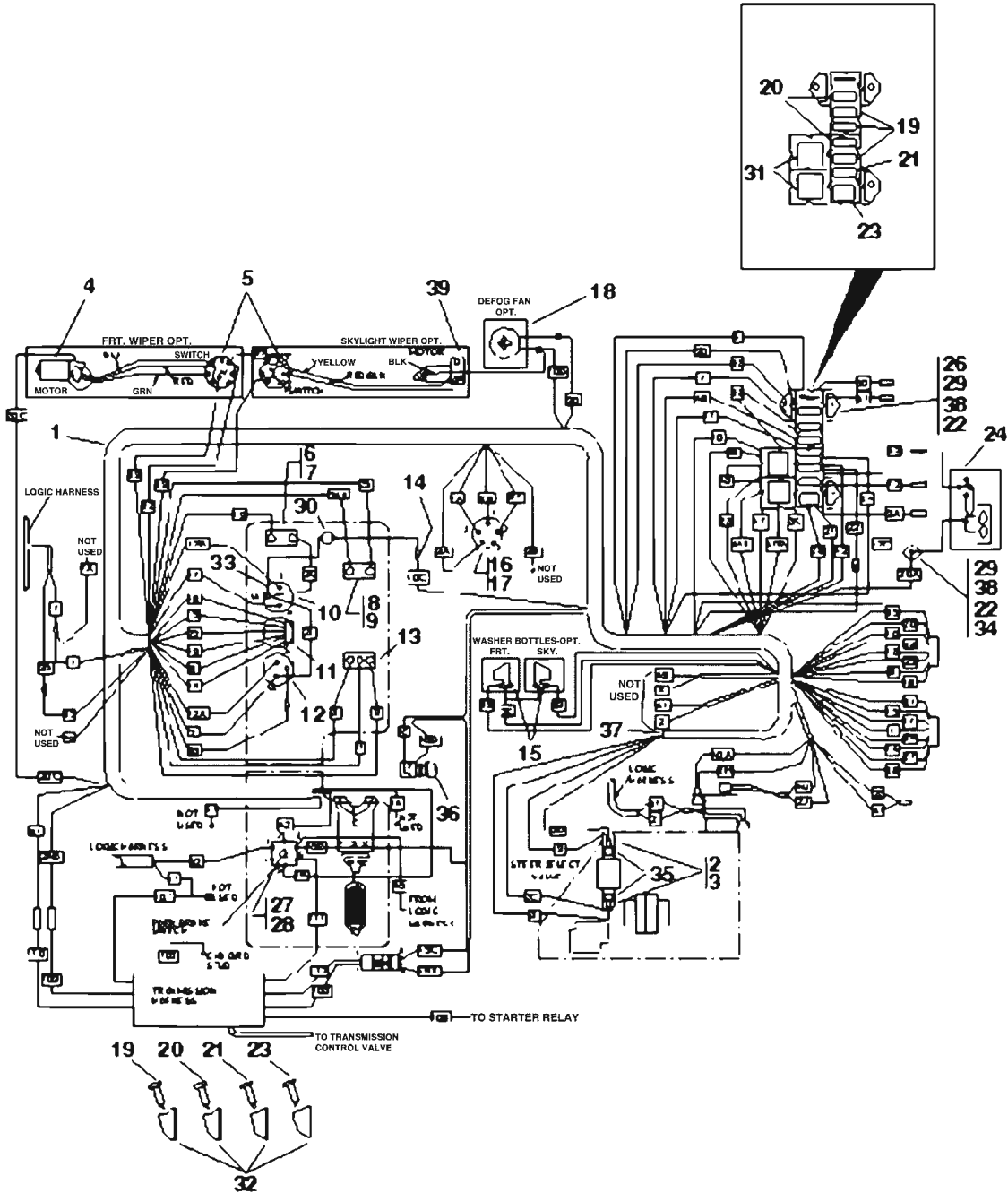

PH1270

SECTION 7 - ELECTRICAL

FIGURE 7-3. ELECTRICAL SYSTEM - CAB HARNESS (SN 9909 through 13197)

ITEM	PART NUMBER	QTY	DESCRIPTION	REV
1	7117704	1	Harness, Cab (Includes Item 2)	
2	8220882	2	Connector, Solenoid	
3	8526035	AR	Sealant	
4	7112511	1	Motor Kit, Windshield Wiper	
5	8033201	2	Switch, Windshield Washer/Wiper	
6	8223442	1	Switch, Test	
7	8580312	1	Boot, Test Switch	
8	8223405	1	Button, Horn	
9	8580311	1	Boot, Horn Button	
10	8464212	1	Gauge, Fuel	
11	8466305	1	Gauge, Warning Lights	
12	8467014	1	Hourmeter	
13	8223220	1	Switch, Steer Select	
14	8220050	1	Terminal - Male	
15	8033065	1	Washer Reservoir Assembly	
16	8223436	1	Switch, Ignition (w/Keys)	
17	8223438	1	Key, Ignition (Not Shown)	
18	8033078	1	Fan, Defrost	
19	8229233	2	Fuse, 7.5 amp (3 required on Closed Cab)	
20	8229234	3	Fuse, 10 amp	
21	8229235	1	Fuse, 20 amp (Opt Light Package)	
22	8305002	4	Nut, Hex #10	
23	8229238	2	Fuse, 40 Amps	
24	8223024	1	Switch Kit, Heater	
25	8584001	AR	Wrap, Tie (Not Shown)	
26	8307106	3	Washer, Flat 5/16in LT	
27	8223444	1	Switch, Emergency Brake	
28	8223445	1	Guard, Switch	
29	8307003	4	Washer, Lock #10	
30	8469028	1	Warning Light	
31	8225117	2	Relay	
32	8582007	4	Clip, Spare Fuse	
33	8220008	1	Terminal, Ring #10	
34	8307027	1	Washer, Lock Ext Tooth 5/16in	
35	8032756	2	Solenoid, Steer Select	
36	8223025	1	Switch, Brake	
37	8584003	1	Wrap, Tie (Not Shown)	
38	8307111	4	Washer, Flat #10	
39	8034810	1	Skylight Wiper Motor	

SECTION 7 - ELECTRICAL

FIGURE 7-4. ELECTRICAL SYSTEM - ENGINE HARNESS (8042 Prior to SN 0207; 10042 Prior to SN 0212)

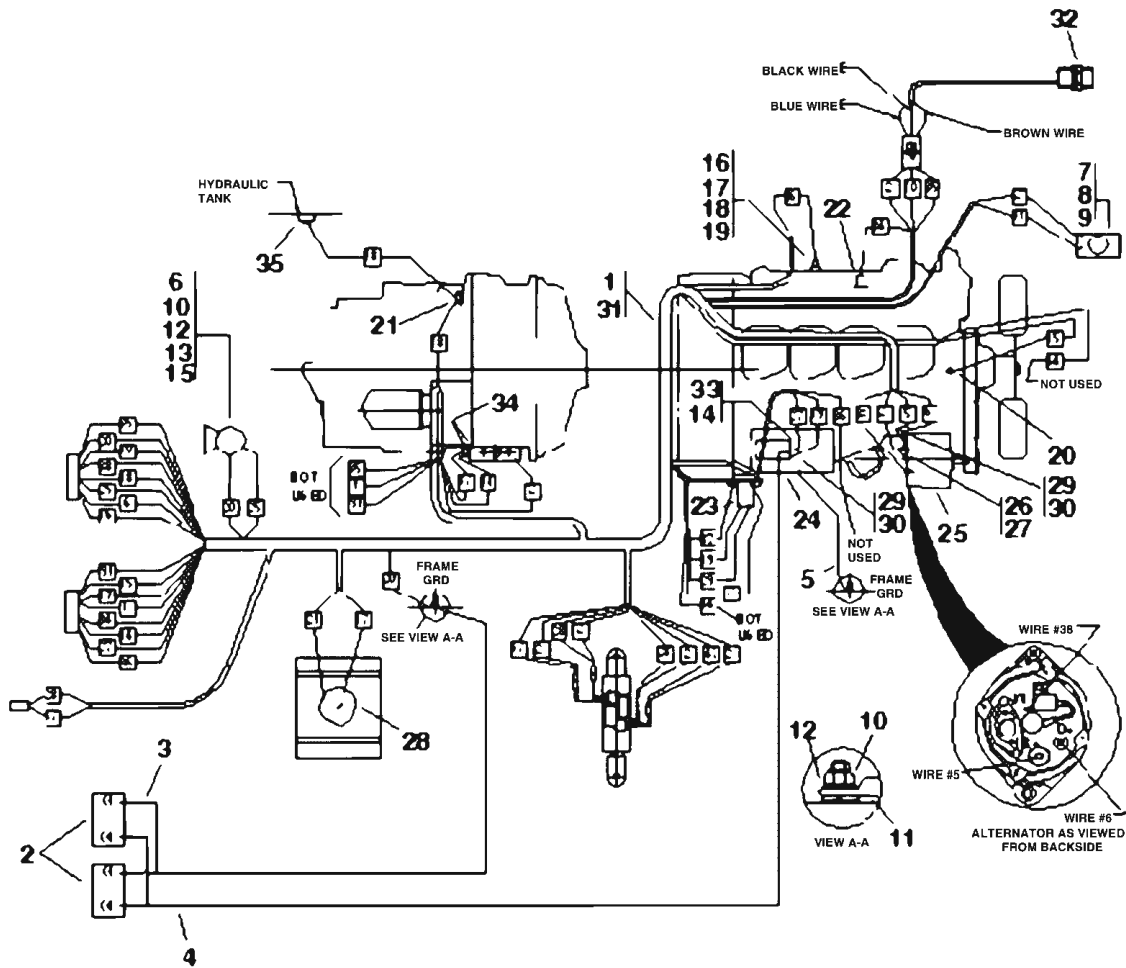

PH0610

SECTION 7 - ELECTRICAL

FIGURE 7-4. ELECTRICAL SYSTEM - ENGINE HARNESS (8042 Prior to SN 0207; 10042 Prior to SN 0212)

ITEM	PART NUMBER	QTY	DESCRIPTION	REV
1	7098864	1	Harness, Engine	
2	8270014	2	Battery, 12 Volt	
3	7114612	1	Cable, Battery - Negative	
4	7098762	1	Cable, Battery - Positive	
5	7068651	1	Cable, Battery Ground	
6	8270602	1	Horn	
7	8270617	1	Alarm, Backup	
8	8305004	2	Nut, Hex, 1/4-20	
9	8307002	2	Washer, Lock 1/4in	
10	8305006	4	Nut, Hex, 5/16-18	
11	8307006	2	Washer, Lock 7/16in	
12	8307106	4	Washer, Flat 5/16in	
13	8307004	1	Washer, Lock 5/16in	
14	8305438	1	Nut, Hex Jam M10	
15	8303697	2	HHCS, 5/16-18 x 3/4in	
16	8310041	1	Washer, Lock, Ext. Tooth #8	
17	8305201	1	Nut, Hex, Brass #8-32	
18	8220073	1	Terminal, Slip-On Male #10 SCR	
19	8223510	1	Sender, Low Oil Pressure 1/8-27	
20	8223217	1	Sender, Water Temperature	
21	8223216	1	Switch, Transmission Temperature	
22	8033406	1	Solenoid, Fuel Run (Used on CAV Injection Pumps)	
22	8034813	1	Solenoid, Fuel Run (Used on Bosch Injection Pumps)	
23	8277162	1	Relay, Starter	
24	8033340	1	Starter (Includes Starter Solenoid)	
25	8270221	1	Alternator	
26	8307022	1	Washer, Lock M8	
27	8305043	1	Nut, Hex M8-1.25	
28	7118222	1	Sender, Fuel Level	
29	8310077	3	Nut, Hex Jam M5-0.8	
30	8310078	3	Washer, Lock M5	
31	8584001	AR	Tie Wrap (Not Shown)	
32	7099882	1	Boom Sensor - Angle	
33	8307023	1	Washer, Lock M10	
34	8303987	2	Screw, Slotted #8	
35	8223217	1	Switch, Hydraulic Oil Temperature	

SECTION 7 - ELECTRICAL

FIGURE 7-5. ELECTRICAL SYSTEM - ENGINE HARNESS (8042 SN 0207 through 1598; 10042 SN 0212 through 1598; 10054 Prior to SN 1599)

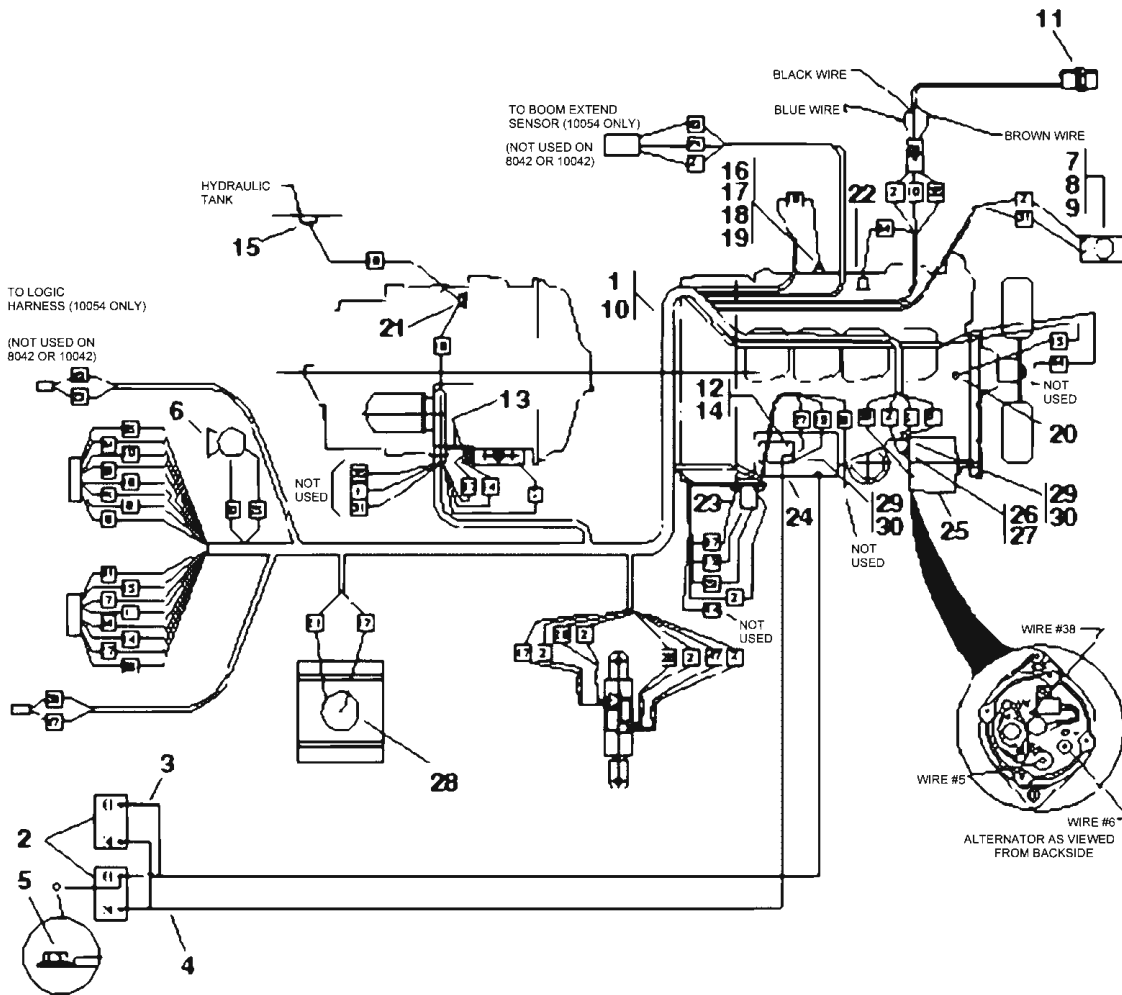

PH0611

SECTION 7 - ELECTRICAL

FIGURE 7-5. ELECTRICAL SYSTEM - ENGINE HARNESS (8042 SN 0207 through 1598; 10042 SN 0212 through 1598; 10054 Prior to SN 1599)

ITEM	PART NUMBER	QTY	DESCRIPTION	REV
1	7126684	1	Harness, Engine	
2	8270014	2	Battery, 12 Volt	
3	7114542	1	Cable, Dual Battery - Negative	
4	7098762	1	Cable, Dual Battery - Positive	
5	8310202	1	HHCS, 3/8 x 3/4in	
6	8270602	1	Horn (Includes Mounting Hardware)	
7	8270617	1	Alarm, Backup	
8	8305004	2	Nut, Hex, 1/4-20	
9	8307002	2	Washer, Lock 1/4in	
10	8584001	AR	Tie Wrap (Not Shown)	
11	7099882	1	Boom Sensor - Angle	
12	8307023	1	Washer, Lock M10	
13	8303987	2	Screw, Slotted #8	
14	8305438	1	Nut, Hex Jam M10	
15	8223217	1	Switch, Hydraulic Oil Temperature	
16	8310041	1	Washer, Lock, Ext Tooth #8	
17	8305201	1	Nut, Hex, Brass #8-32	
18	8220073	1	Terminal, Slip-On Male #10 SCR	
19	8223510	1	Sender, Low Oil Pressure 1/8-27	
20	8223217	1	Sender, Water Temperature	
21	8223216	1	Switch, Transmission Temperature	
22	8033406	1	Solenoid, Fuel Run (Used on CAV Injection Pumps)	
22	8034813	1	Solenoid, Fuel Run (Used on Bosch Injection Pumps)	
23	8277162	1	Relay, Starter	
24	8033340	1	Starter (Includes Starter Solenoid)	
25	8270221	1	Alternator	
26	8307022	1	Washer, Lock M8	
27	8305043	1	Nut, Hex M8-1.25	
28	7118222	1	Sender, Fuel Level	
29	8310077	3	Nut, Hex Jam M5-0.8	
30	8310078	3	Washer, Lock M5	

SECTION 7 - ELECTRICAL

FIGURE 7-6. ELECTRICAL SYSTEM - ENGINE HARNESS (8042 SN 1599 through 5234; 10042 SN 1599 through 5250; 10054 SN 1599 through 5274)

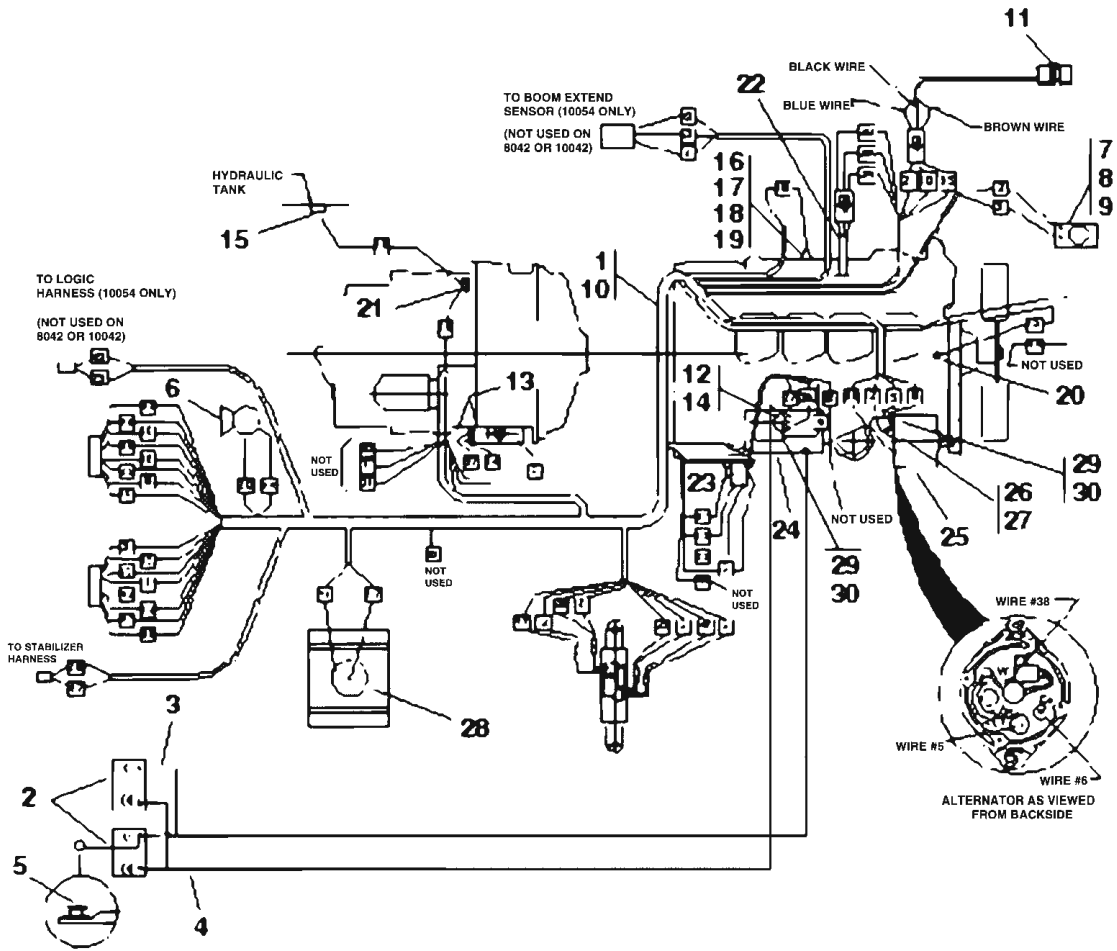

PH0613

SECTION 7 - ELECTRICAL

FIGURE 7-6. ELECTRICAL SYSTEM - ENGINE HARNESS (8042 SN 1599 through 5234; 10042 SN 1599 through 5250; 10054 SN 1599 through 5274)

ITEM	PART NUMBER	QTY	DESCRIPTION	REV
1	7126684	1	Harness, Engine	
2	8270014	2	Battery, 12 Volt	
3	7114542	1	Cable, Dual Battery - Negative	
4	7098762	1	Cable, Dual Battery - Positive	
5	8310202	1	HHCS, 3/8 x 3/4in	
6	8270602	1	Horn (Includes Mounting Hardware)	
7	8270617	1	Alarm, Backup	
8	8305004	2	Nut, Hex, 1/4-20	
9	8307002	2	Washer, Lock 1/4in	
10	8584001	AR	Tie Wrap (Not Shown)	
11	7099882	1	Boom Sensor - Angle	
12	8307023	1	Washer, Lock M10	
13	8303987	2	Screw, Slotted #8	
14	8305438	1	Nut, Hex Jam M10	
15	8223217	1	Switch, Hydraulic Oil Temperature	
16	8310041	1	Washer, Lock, Ext Tooth #8	
17	8305201	1	Nut, Hex, Brass #8-32	
18	8220073	1	Terminal, Slip-On Male #10 SCR	
19	8223532	1	Sender, Low Oil Pressure M10	
20	8223217	1	Sender, Water Temperature	
21	8223216	1	Switch, Transmission Temperature	
22	8033406	1	Solenoid, Fuel Run (Used on CAV Injection Pumps)	
22	8034813	1	Solenoid, Fuel Run (Used on Bosch Injection Pumps)	
23	8277162	1	Relay, Starter	
24	8033340	1	Starter (Includes Starter Solenoid)	
25	8270221	1	Alternator	
26	8307022	1	Washer, Lock M8	
27	8305043	1	Nut, Hex M8-1.25	
28	7118222	1	Sender, Fuel Level	
29	8310077	3	Nut, Hex Jam M5-0.8	
30	8310078	3	Washer, Lock M5	

SECTION 7 - ELECTRICAL

FIGURE 7-7. ELECTRICAL SYSTEM - ENGINE HARNESS (EPA) (8042 Prior to SN 5236; 10042 Prior to SN 5252; 10054 SN 5275 through 9908)

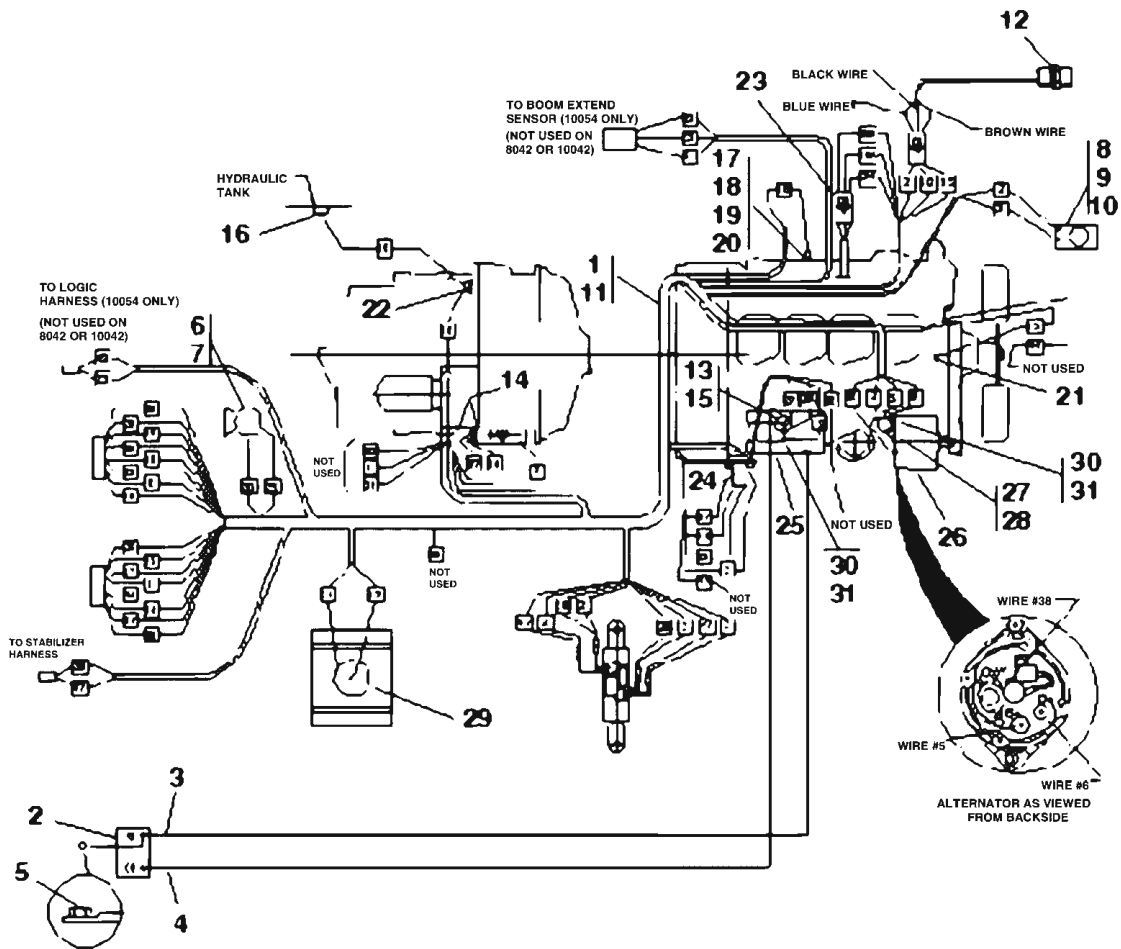

PH0612

SECTION 7 - ELECTRICAL

FIGURE 7-7. ELECTRICAL SYSTEM - ENGINE HARNESS (EPA) (8042 Prior to SN 5236; 10042 Prior to SN 5252; 10054 SN 5275 through 9908)

ITEM	PART NUMBER	QTY	DESCRIPTION	REV
1	7126684	1	Harness, Engine	
2	8270134	1	Battery, 12 Volt	
3	7129392	1	Cable, Single Battery - Negative	
4	7129382	1	Cable, Single Battery - Positive	
5	8310202	1	HHCS, 3/8 x 3/4in	
6	7134832	1	Kit, Horn (Includes Item 7 and female terminal to replace ring terminal on early production units)	
7	8270625	1	Horn (Includes Mounting Hardware)	
8	8270617	1	Alarm, Backup	
9	8305004	2	Nut, Hex, 1/4-20	
10	8307002	2	Washer, Lock 1/4in	
11	8584001	AR	Tie Wrap (Not Shown)	
12	7099882	1	Boom Sensor - Angle	
13	8307023	1	Washer, Lock M10	
14	8303987	2	Screw, Slotted #8	
15	8305438	1	Nut, Hex Jam M10	
16	8223217	1	Switch, Hydraulic Oil Temperature	
17	8310041	1	Washer, Lock, Ext Tooth #8	
18	8305201	1	Nut, Hex, Brass #8-32	
19	8220073	1	Terminal, Slip-On Male #10 SCR	
20	8223532	1	Sender, Low Oil Pressure M10	
21	8223217	1	Sender, Water Temperature	
22	8223216	1	Switch, Transmission Temperature	
23	8035276	1	Solenoid, Fuel Run	
24	8277162	1	Relay, Starter	
25	8033340	1	Starter (Includes Starter Solenoid)	
26	8270221	1	Alternator	
27	8307022	1	Washer, Lock M8	
28	8305043	1	Nut, Hex M8-1.25	
29	7118222	1	Sender, Fuel Level	
30	8310077	3	Nut, Hex Jam M5-0.8	
31	8310078	3	Washer, Lock M5	

SECTION 7 - ELECTRICAL

FIGURE 7-8. ELECTRICAL SYSTEM - ENGINE HARNESS (EPA) (SN 9909 through 13197)

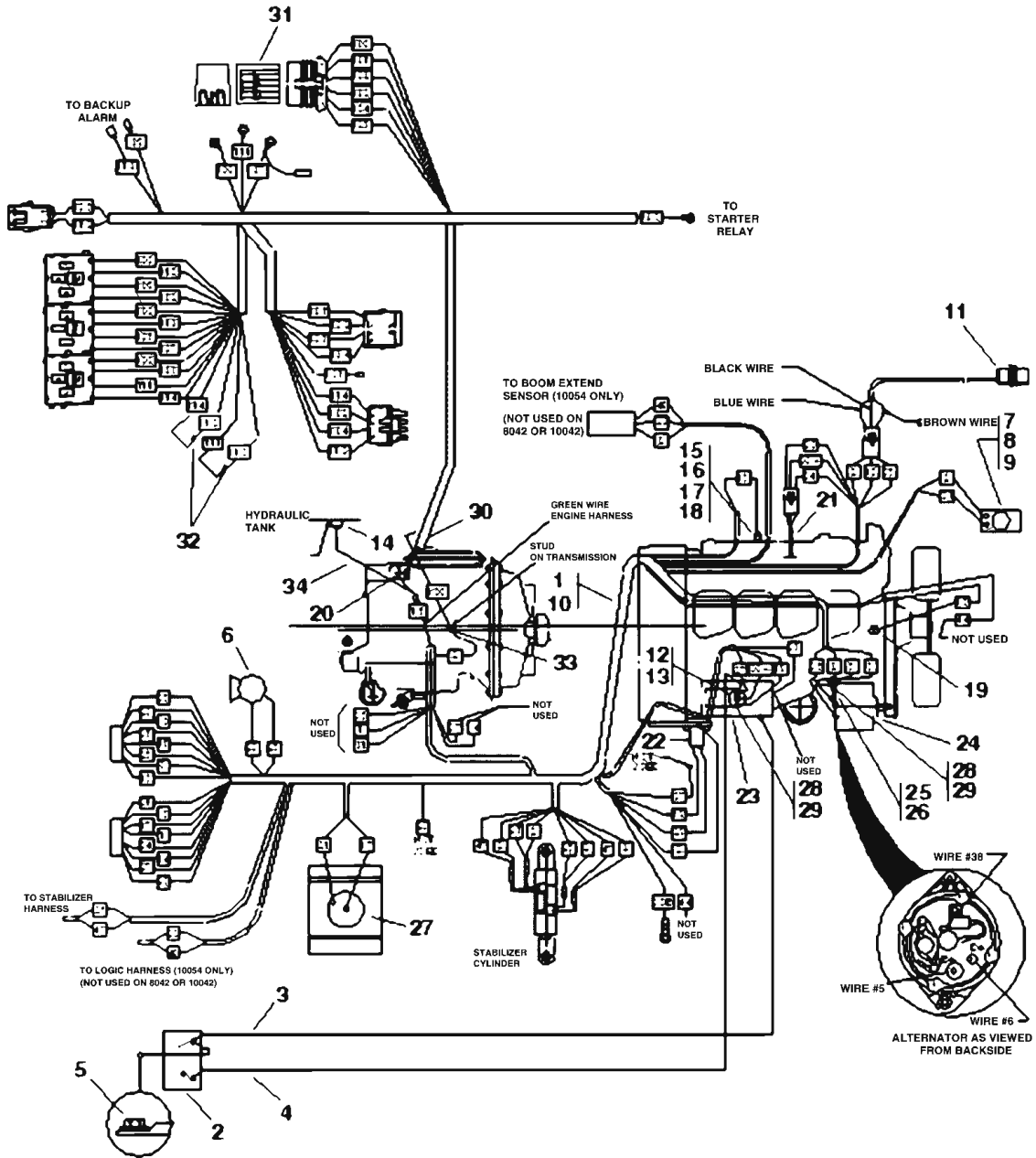

PH1280

SECTION 7 - ELECTRICAL

FIGURE 7-8. ELECTRICAL SYSTEM - ENGINE HARNESS (EPA) (SN 9909 through 13197)

ITEM	PART NUMBER	QTY	DESCRIPTION	REV
1	7134894	1	Harness, Engine	
2	8270134	1	Battery, 12 Volt	
3	7129392	1	Cable, Single Battery - Negative	
4	7129382	1	Cable, Single Battery - Positive	
5	8310202	1	HHCS, 3/8 x 3/4in	
6	8270625	1	Horn (Includes Mounting Hardware)	
7	8270617	1	Alarm, Backup	
8	8305004	2	Nut, Hex, 1/4-20	
9	8307002	2	Washer, Lock 1/4in	
10	8584001	AR	Tie Wrap (Not Shown)	
11	7099882	1	Boom Sensor - Angle	
12	8307023	1	Washer, Lock M10	
13	8305438	1	Nut, Hex Jam M10	
14	8223217	1	Switch, Hydraulic Oil Temperature	
15	8310041	1	Washer, Lock, Ext Tooth #8	
16	8305201	1	Nut, Hex, Brass #8-32	
17	8220073	1	Terminal, Slip-On Male #10 SCR	
18	8223532	1	Sender, Low Oil Pressure M10	
19	8223217	1	Sender, Water Temperature	
20	8223216	1	Switch, Transmission Temperature	
21	8035276	1	Solenoid, Fuel Run	
22	8277162	1	Relay, Starter	
23	8033340	1	Starter (Includes Starter Solenoid)	
24	8270221	1	Alternator	
25	8307022	1	Washer, Lock M8	
26	8305043	1	Nut, Hex M8-1.25	
27	7118222	1	Sender, Fuel Level	
28	8310077	3	Nut, Hex Jam M5-0.8	
29	8310078	3	Washer, Lock M5	
30	7150402	1	Transmission Harness	
31	8035805	1	Diode Pac	
32	8035806	2	Diode - 3 amp 1000 volt	
33	8305038	2	Nut M10	
34	7150521	1	Wire Assembly	

SECTION 7 - ELECTRICAL

FIGURE 7-9. LIGHTING SYSTEM

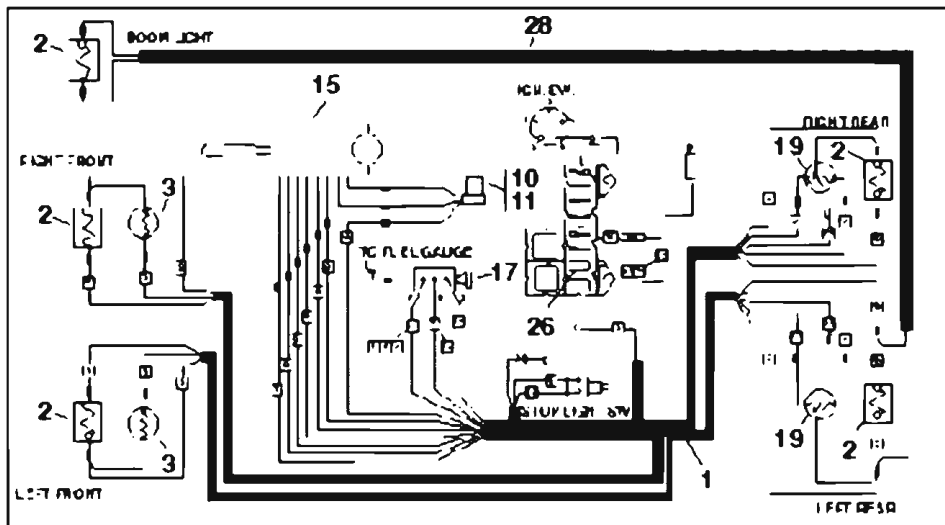
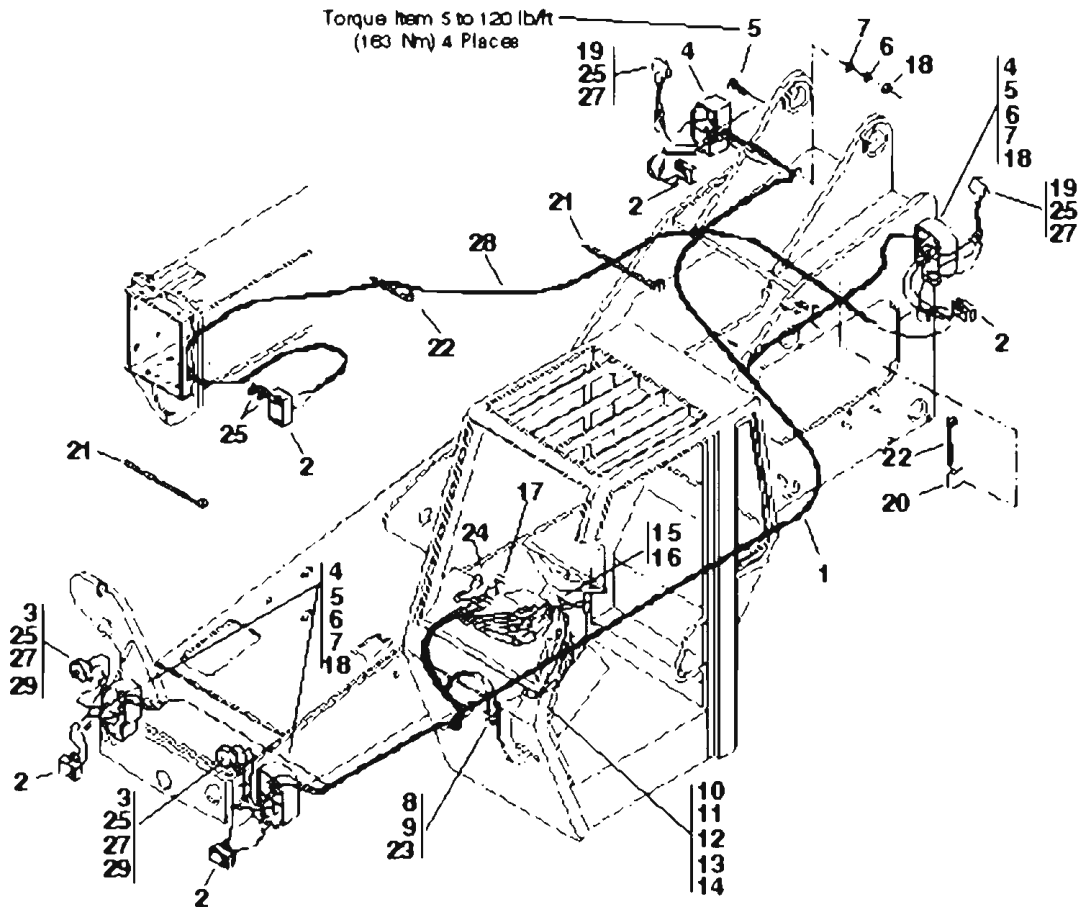

PH0432

SECTION 7 - ELECTRICAL

FIGURE 7-9. LIGHTING SYSTEM

ITEM	PART NUMBER	QTY	DESCRIPTION	REV
1	7098973	1	Harness, Wiring	
2	5721202	5	Light, Head and Work	
3	8500036	2	Light, Turn Signal	
4	7112302	4	Bracket, Mounting	
5	8303632	8	HHCS, 5/8-11 x 2-1/2in	
6	8307009	8	Washer, Lock 5/8in	
7	8307207	8	Washer, Flat 5/8in Heavy	
8	8223025	1	Switch, Momentary Brake Light	
9	7111191	1	Plate, Actuator	
10	8223424	1	Mount, Flasher	
11	8500201	1	Flasher	
12	8303837	2	Screw, Rd. Hd Mach., #10-24 x 3/4in	
13	8305627	2	Nut, Hex Lock #10-24	
14	8307111	2	Washer, Flat #10	
15	8223419	1	Switch, Turn Signal	
16	7124331	1	Conduit, 1/2 I.D. x 5ft - Cut to Fit	
17	8223016	1	Switch, Head and Tail Lights	
18	8305014	8	Nut, Hex 5/8-11	
19	8500009	2	Stop/Turn Signal Light	
20	8584018	6	Mount, Tie	
21	8584003	6	Tie, Plastic, 14.8in	
22	8584001	27	Tie, Plastic, 6.7in	
23	8305405	1	Nut, Hex Jam 3/8in	
24	7058372	1	Fuel Gauge Light Assembly	
25	8307206	AR	Washer, Flat 1/2in Heavy	
26	8229235	1	Fuse, 20 amp	
27	8220050	6	Terminal, Blade Male 1/4in	
28	7110782	1	Cord, Boom Work Light	
29	8310058	4	Washer, Flat 5/8 Hardened	
26	8229235	1	Fuse, 20 amp	
27	8220050	6	Terminal, Blade Male 1/4in	
28	7110782	1	Cord, Boom Work Light	
29	8310058	4	Washer, Flat 5/8 Hardened	

SECTION 7 - ELECTRICAL

FIGURE 7-10. OUTRIGGER ELECTRICAL HARNESS (10042/10054 ONLY)

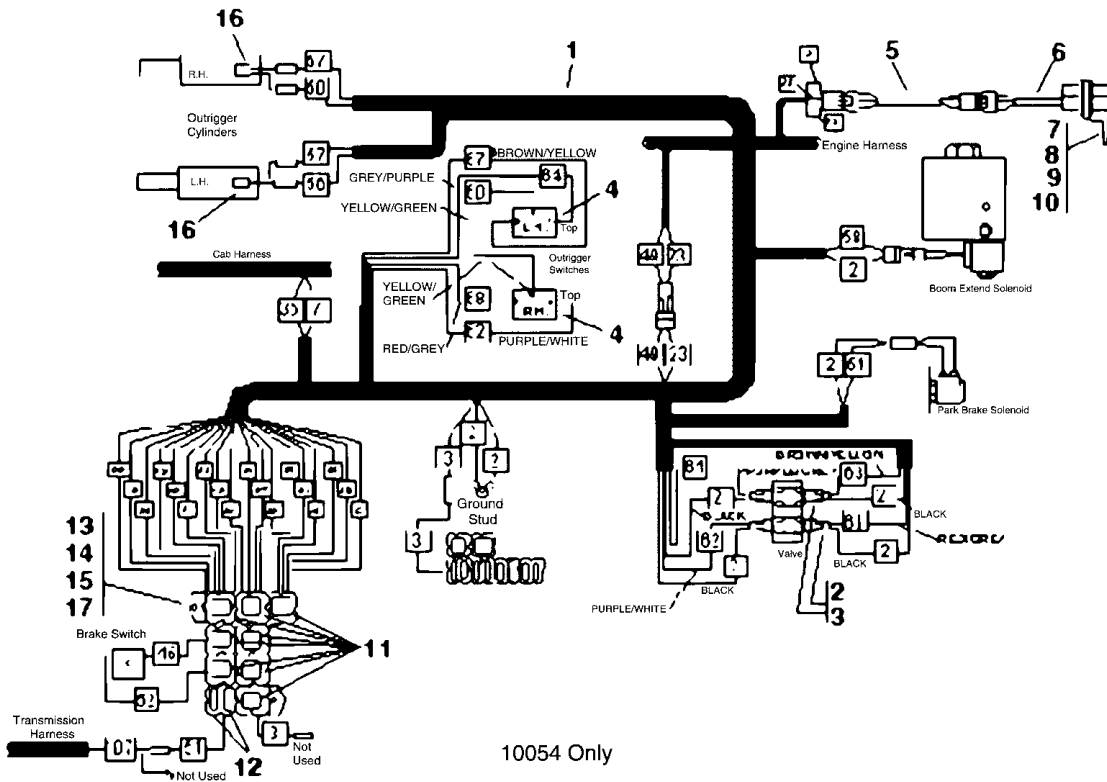
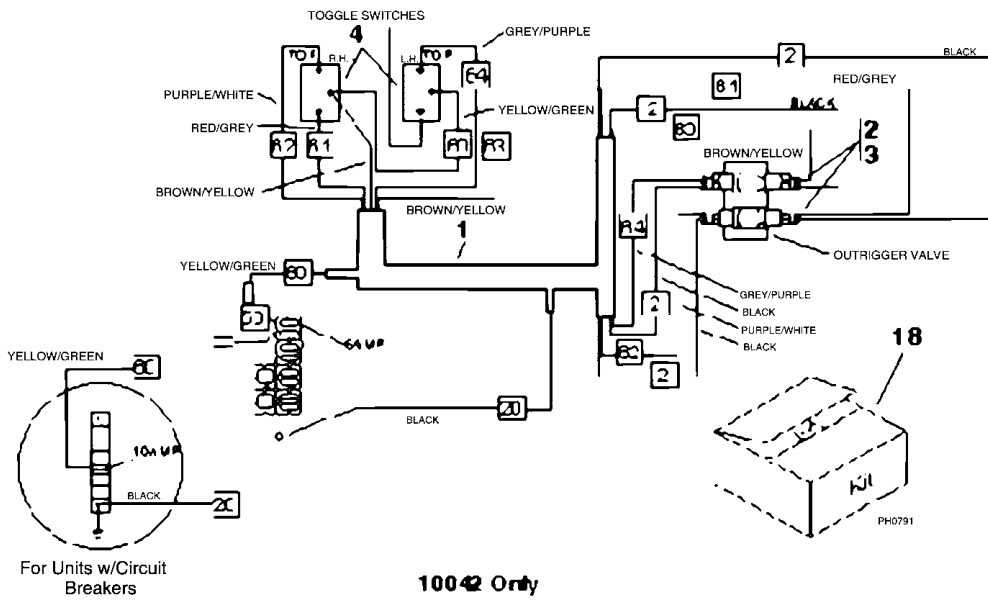

SECTION 7 - ELECTRICAL

FIGURE 7-10. OUTRIGGER ELECTRICAL HARNESS (10042/10054 ONLY)

ITEM	PART NUMBER	QTY	DESCRIPTION	REV
1	7099923	1	Harness, Wiring (Includes Items 2 & 3) - (10042 Only)	
1	7115114	1	Harness, Logic (Includes Items 2 & 3) - (10054 Only)	
2	8220882	4	Connector, Solenoid (Includes Item 3)	
3	8688026	4	Seal, Connector (Not Shown)	
4	8223221	2	Switch, Toggle	
5	7112592	1	Wire Assembly	
6	7138469	1	Kit, Boom Sensor (Prior to SN 9916)	
6	7099882	1	Sensor, Boom (SN 9916 to Present)	
7	7112582	1	Clip (Prior to SN 9916)	
7	7138468	1	Clip (SN 9916 to Present)	
8	8303738	2	HHCS, 3/8-16 x 7/8in	
9	8307005	2	Washer, Lock 3/8in	
10	8310113	2	Nut, Cage 3/8-16	
11	8225117	8	Relay	
12	8229233	2	Fuse, 7.5 amp	
13	8307111	2	Washer, Flat #10	
14	8305002	2	Nut, Hex #10	
15	8307003	2	Washer, Lock #10	
16	8223525	2	Switch, Pressure	
17	8307106	2	Washer, Flat 5/16 LT	
		Ref	KITS	
18	7116632	1	Kit, Outrigger, Wire Harness (This kit is available to convert 10042 wire harness for use with circuit breakers)	

SECTION 8 - DECALS AND PAINT

SECTION 8 - DECALS AND PAINT

FIGURE 8-1. DECALS AND PAINT

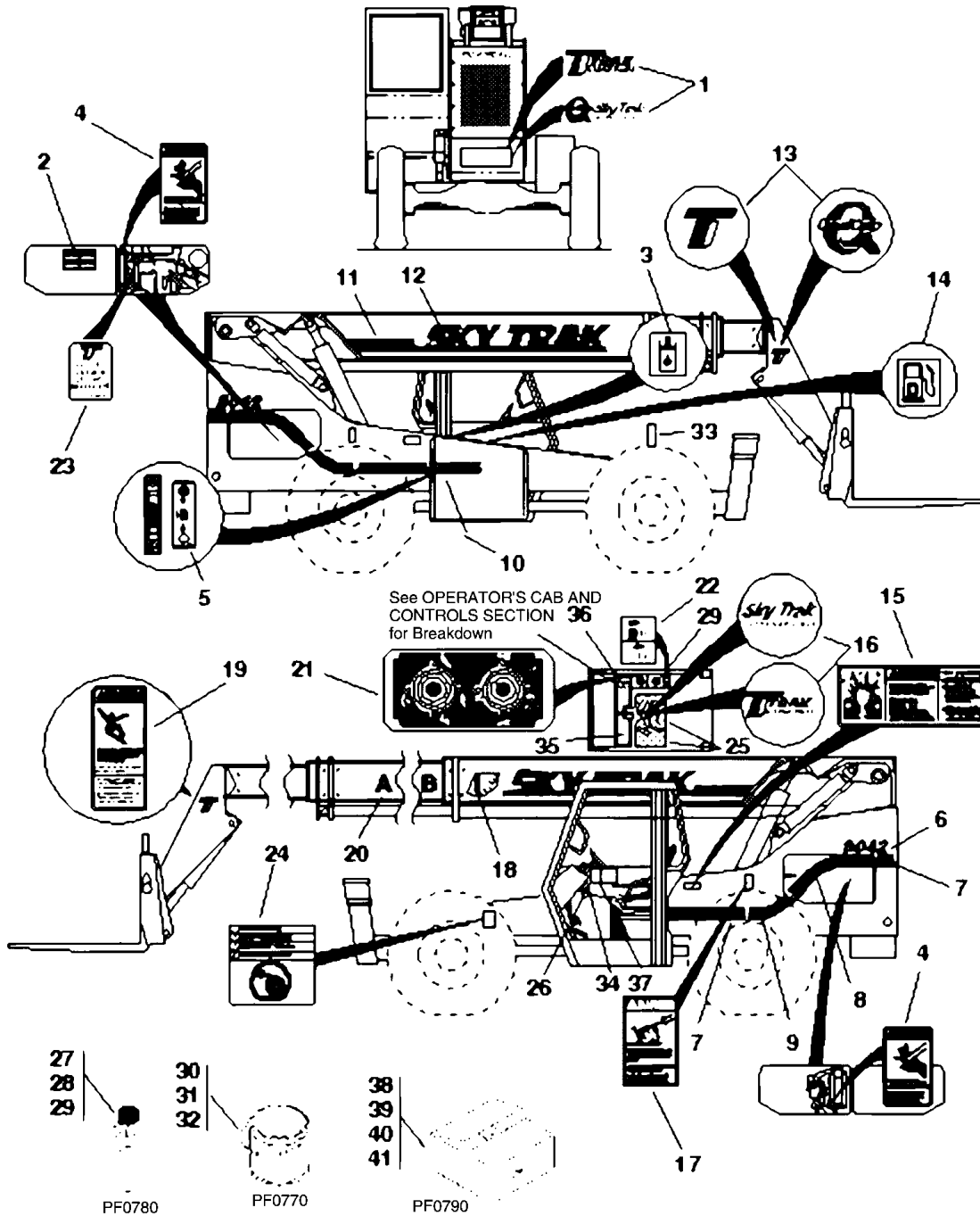

PH0323

SECTION 8 - DECALS AND PAINT

FIGURE 8-1. DECALS AND PAINT

ITEM	PART NUMBER	QTY	DESCRIPTION	REV
1	4106872	1	Decal, TRAK INTERNATIONAL (Earlier Models)	
1	4110113	1	Decal, Omni Quip (Later Models)	
2	4107352	1	Decal, Lubrication and Maintenance Chart	
3	4100181	1	Decal, Hydraulic Oil	
4	4107412	2	Decal, Moving Parts Warning - Domestic Only	
4	4108081	2	Decal, Moving Parts Warning - Export Only	
5	4108302	1	Decal, Hydraulic Oil Level	
6	4110123	2	Decal, 8042	
6	4110124	2	Decal, 10042	
6	4110125	2	Decal, 10054	
7	4107232	2	Decal, Rear Stripe	
8	4107243	2	Decal, Upper Curve Stripe	
9	4107252	2	Decal, Lower Curve Stripe	
10	4110119	1	Decal, Stripe	
11	4107272	2	Decal, Boom Stripe	
12	4107283	2	Decal, SKYTRAK	
13	4106781	2	Decal, TI Logo (Earlier Models)	
13	4108441	2	Decal, OmniQuip (Later Models)	
14	4105171	1	Decal, Diesel Fuel	
15	4107402	1	Decal, Explosion Warning	
15	4108041	1	Decal, Explosion Warning - Export Only	
16	4106681	1	Decal, TRAK INTERNATIONAL (Steering Wheel Center) (Earlier Models)	
16	4110120	1	Decal, SkyTrak International (Steering Wheel Center) (Later Models)	
17	4107601	1	Decal, Stabilizer	
18	4105262	1	Decal, Boom Angle	
19	4107452	1	Decal, Carrying Personnel Warning - Domestic Only	
19	4106991	1	Decal, Carrying Personnel Warning - Export Only	
20	4107442	1	Decal, Boom Extend Letters (Off White)	
20	4107482	1	Decal, Boom Extend Letters (Black)	
21	4107462	1	Decal, Side Console	
22	4105621	1	Decal, Optional Hydraulics	
23	4107901	1	Decal, Low Engine Idle	
24	4107001	1	Decal, Hydrofill - Export Only	
25	7010491-OM	1	Safety Walk, 6in x 12in	
26	4108201	1	Ring, Key	
27	8528074	1 gal	Paint, Orange, Acrylic Enamel (Service Repaint)	
28	8528100	1 gal	Paint, Black, Acrylic Enamel (Service Repaint)	
29	8528085	1 gal	Paint, Off White, Acrylic Enamel (Service Repaint)	
30	8528071	1 can	Paint, Orange, Acrylic Enamel (16 oz. spray - touch-up)	
31	8528101	1 can	Paint, Black, Acrylic Enamel (16 oz. spray - touch-up)	
32	8528086	1 can	Paint, Off White, Acrylic Enamel (16 oz. spray - touch-up)	
33	4108181	1	Decal, Made in USA	
34	4106761	1	Decal, TI Logo - Closed Cab/Export Only	
35	7111842	1	Decal, Overlay, Left Hand - Export Only (Prior to SN 9909)	
35	7150472	1	Decal, Overlay, Left Hand - Export Only (SN 9909 to Present)	
35	7099352	1	Decal, Overlay, Left Hand - Domestic Only (Prior to SN 9909)	
35	7150371	1	Decal, Overlay, Left Hand - Domestic Only (SN 9909 to Present)	
36	7111832	1	Decal, Overlay, Right Hand - Export Only	

SECTION 8 - DECALS AND PAINT

ITEM	PART NUMBER	QTY	DESCRIPTION	REV
36	7099332	1	Decal, Overlay, Right Hand - Domestic Only	
37	4107342	1	Capacity Charts, 8042 - Domestic Only	
37	4107632	1	Capacity Charts, 8042 - Export Only	
37	4107572	1	Capacity Charts, 10042 - Domestic Only	
37	4107992	1	Capacity Charts, 10042 - Export Only	
37	4107922	1	Capacity Charts, 10054 - Domestic Only	
37	4108002	1	Capacity Charts, 10054 - Export Only	
		Ref	KITS	
38	7099362	1	Kit, Decal Set, 8042/10042 - Domestic Only	
39	7112391	1	Kit, Decal Set, 8042/10042 - Export Only	
40	7116152	1	Kit, Decal Set, 10054 - Domestic Only	
41	7116162	1	Kit, Decal Set, 10054 - Export Only	

SECTION 9 - BOOM AND ATTACHMENTS

SECTION 9 - BOOM AND ATTACHMENTS

FIGURE 9-1. OUTER BOOM

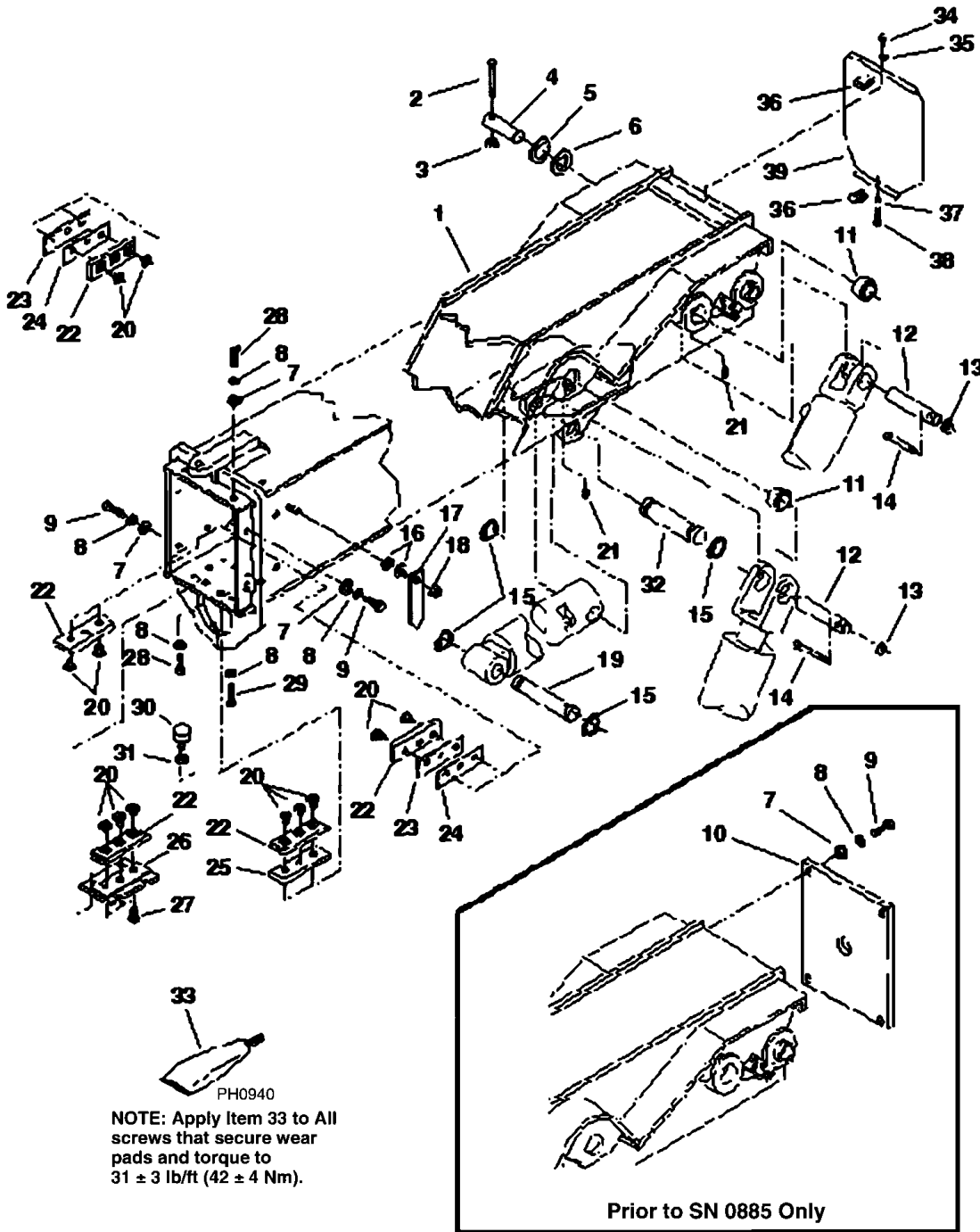

PH0053

SECTION 9 - BOOM AND ATTACHMENTS

FIGURE 9-1. OUTER BOOM

ITEM	PART NUMBER	QTY	DESCRIPTION	REV
1	7116854	1	Outer Boom (SN 0885 to Present)	
1	NLA	1	Outer Boom, For Service, Order Kit 7116871 which includes Items 1, 34 thru 39 (Prior to SN 0885)	
2	8303655	2	HHCS, 5/8-11 x 4.50in	
3	8305643	2	Nut, Hex Lock Elastic 5/8-11	
4	7097682	2	Pin, Boom Pivot	
5	8307910	AR	Washer, Shim 2.75 Dia x .075in	
6	8307911	AR	Washer, Shim 2.75 Dia x .135in	
7	8307204	12	Washer, Flat 3/8in	
8	8307005	22	Washer, Lock 3/8in	
9	8303681	8	HHCS, 3/8-16 x 3/4in	
10	7097382	1	Cover, Rear Boom (Prior to SN 0885)	
11	8065640	4	Bearing, Self-Aligning 2in Dia	
12	7092292	4	Pin, Hoist and Slave Cylinders	
13	8305644	4	Nut, Hex Lock Elastic 1/2-13	
14	8303782	4	HHCS, 1/2-13 x 4in	
15	8642224	4	Ring, Retaining 2in Dia	
16	8307113	2	Washer, Flat 7/16in	
17	7075611	1	Pointer	
18	8305647	1	Nut, Hex Lock 7/16-14	
19	7096562	1	Pin, Extend Cylinder (rod end)	
20	7082311	21	Insert, Wear Pad	
21	8520013	4	Fitting, Lube 1/8in Straight	
22	7111572	9	Wear Pad	
23	7082342	AR	Shim, Wear Pad (.07in)	
24	7082362	AR	Shim, Wear Pad (.13in)	
25	7096882	2	Spacer, Wear Pad (.62in)	
26	7096772	1	Spacer, Wear Pad (special)	
27	8303041	3	HHCS, 3/8-16 x 1/2in	
28	8303620	8	HHCS, 3/8-16 x 1in	
29	8303621	6	HHCS, 3/8-16 x 1-1/2in	
30	5724622	1	Bumper, Rubber	
31	8305645	1	Nut, Hex Lock Elastic 3/8-16	
32	7096552	1	Pin, Extend Cylinder (base end)	
33	8526036	AR	Tube, Thread Locking Compound .5cc	
34	8303697	1	HHCS, 5/16-18 x 3/4in	
35	8307106	1	Washer, Flat 5/16in	
36	8305906	2	Nut, Retainer 5/16-18	
37	8307004	1	Washer, Lock 5/16in	
38	8303715	1	HHCS, 5/16-18 x 1-1/2in	
39	7116792	1	Cover, Rear Boom (SN 0885 to Present)	

SECTION 9 - BOOM AND ATTACHMENTS

FIGURE 9-2. INTERMEDIATE BOOM - 8042 & 10042

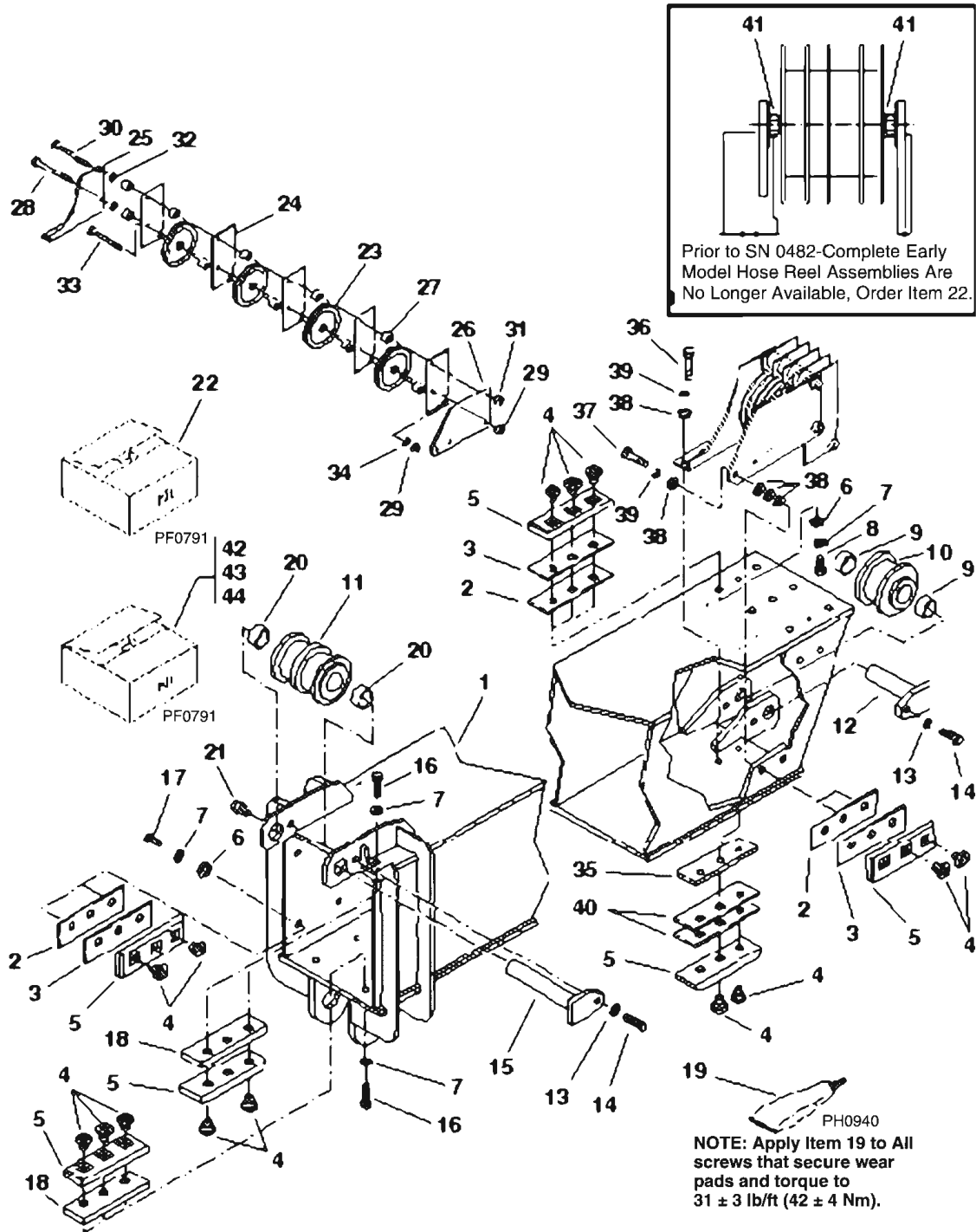

PH0042

SECTION 9 - BOOM AND ATTACHMENTS

FIGURE 9-2. INTERMEDIATE BOOM - 8042 & 10042

ITEM	PART NUMBER	QTY	DESCRIPTION	REV
1	NLA	1	Intermediate Boom, For Service, Order P/N 7116784, (Prior to SN 0219)	
1	NLA	1	Intermediate Boom, For Service, Order P/N 7116784, (SN 0219 through 0453)	
1	NLA	1	Intermediate Boom, For Service, Order P/N 7116784 and Kit P/N 7117072 (SN 0454 through 0481)	
1	7116784	1	Intermediate Boom (SN 0482 to Present)	
2	7082362	AR	Shim, Wear Pad (.13in thick)	
3	7082342	AR	Shim, Wear Pad (.07in thick)	
4	7082311	37	Insert, Wear Pad	
5	7111572	16	Wear Pad	
6	8307204	25	Washer, Flat 3/8in	
7	8307005	37	Washer, Lock 3/8in	
8	8303620	9	HHCS, 3/8-16 x 1in	
9	NLA	2	Bushing, Chain Sheave, For Service, Order Kit P/N 7138980	
10	NLA	1	Sheave, Retract Chain, For Service, Order Kit P/N 7138980	
11	NLA	1	Sheave, Extend Chain, For Service, Order Kit P/N 7117513 (Prior to SN 0219)	
11	NLA	1	Sheave, Extend Chain, For Service, Order Kit P/N 7117523 (SN 0219 through 0453)	
11	7114112	1	Sheave, Extend Chain (SN 0454 to Present)	
12	NLA	1	Pin, Retract Chain Sheave, For Service, Order Kit P/N 7138980	
13	8307007	2	Washer, Lock 1/2in	
14	8303735	2	HHCS, 1/2-13 x 3/4in	
15	NLA	1	Pin, Extend Chain Sheave, For Service, Order Kit P/N 7117513 (Prior to SN 0219)	
15	NLA	1	Pin, Extend Chain Sheave, For Service, Order Kit P/N 7117523 (SN 0219 through 0453)	
15	7117572	1	Pin, Extend Chain Sheave (SN 0454 to Present)	
16	8303621	10	HHCS, 3/8-16 x 1-1/2in	
17	8303681	16	HHCS, 3/8-16 x 3/4in	
18	7096882	4	Spacer, Wear Pad (0.62 thick)	
19	8526036	AR	Tube, Thread Locking Compound .5cc	
20	NLA	2	Bushing, Chain Sheave, For Service, Order Kit P/N 7117513 (Prior to SN 0219)	
20	NLA	2	Bushing, Chain Sheave, For Service, Order Kit (SN 0219 through 0453)	
20	7117502	2	Bushing, Chain Sheave (SN 0454 to Present)	
21	8520001	1	Fitting, Lube 1/8in Straight	
22	7117072	1	Kit, Hose Pulley (Includes Items 23 thru 39)	
23	7116812	4	Pulley, Roller	
24	7116642	5	Divider	
25	7116652	1	Bracket, Right Side	
26	7116662	1	Bracket, Left Side	
27	7116691	10	Spacer	
28	8310235	1	Screw, Shoulder 1/2 x 5in	
29	8305645	2	Nut, Lock 3/8-16 Elastic	
30	8310209	1	HHCS, 1/2-13 x 6in	
31	8305644	1	Nut, Lock 1/2-13 Elastic	
32	8307206	2	Washer, Flat 1/2in Heavy (.109 thick)	
33	8310245	1	Screw, Shoulder 1/2 x 4in	
34	8307204	1	Washer, Flat 3/8in Heavy (.083 thick)	

SECTION 9 - BOOM AND ATTACHMENTS

ITEM	PART NUMBER	QTY	DESCRIPTION	REV
35	7096702	1	Spacer, Wear Pad (0.5in thick)	
36	8303679	2	HHCS, 3/8-16 x 1-3/4in	
37	8303675	2	HHCS, 3/8-16 x 1-1/4in	
38	8307204	10	Washer, Flat 3/8in	
39	8307005	4	Washer, Lock 3/8in	
40	7082342	2	Shim, Wear Pad (.075 thick)	
41	8065214	2	Bearing, Hose Pulley (Prior to SN 0481)	
		Ref	KITS	
42	7117513	1	Kit, Extend Chain Sheave (Includes Items 11, 15, 20 & 21) (Prior to SN 0219)	
43	7117523	1	Kit, Extend Chain Sheave Pin (Includes Items 15, 20 & 21) (SN 0219 through 0453)	
44	7138980	1	Kit, Retract Chain Sheave (Includes Items 9, 10, 12 and New Hardware for Rear Boom Cover and Instructions)	

SECTION 9 - BOOM AND ATTACHMENTS

FIGURE 9-3. INNER BOOM - 8042 & 10042

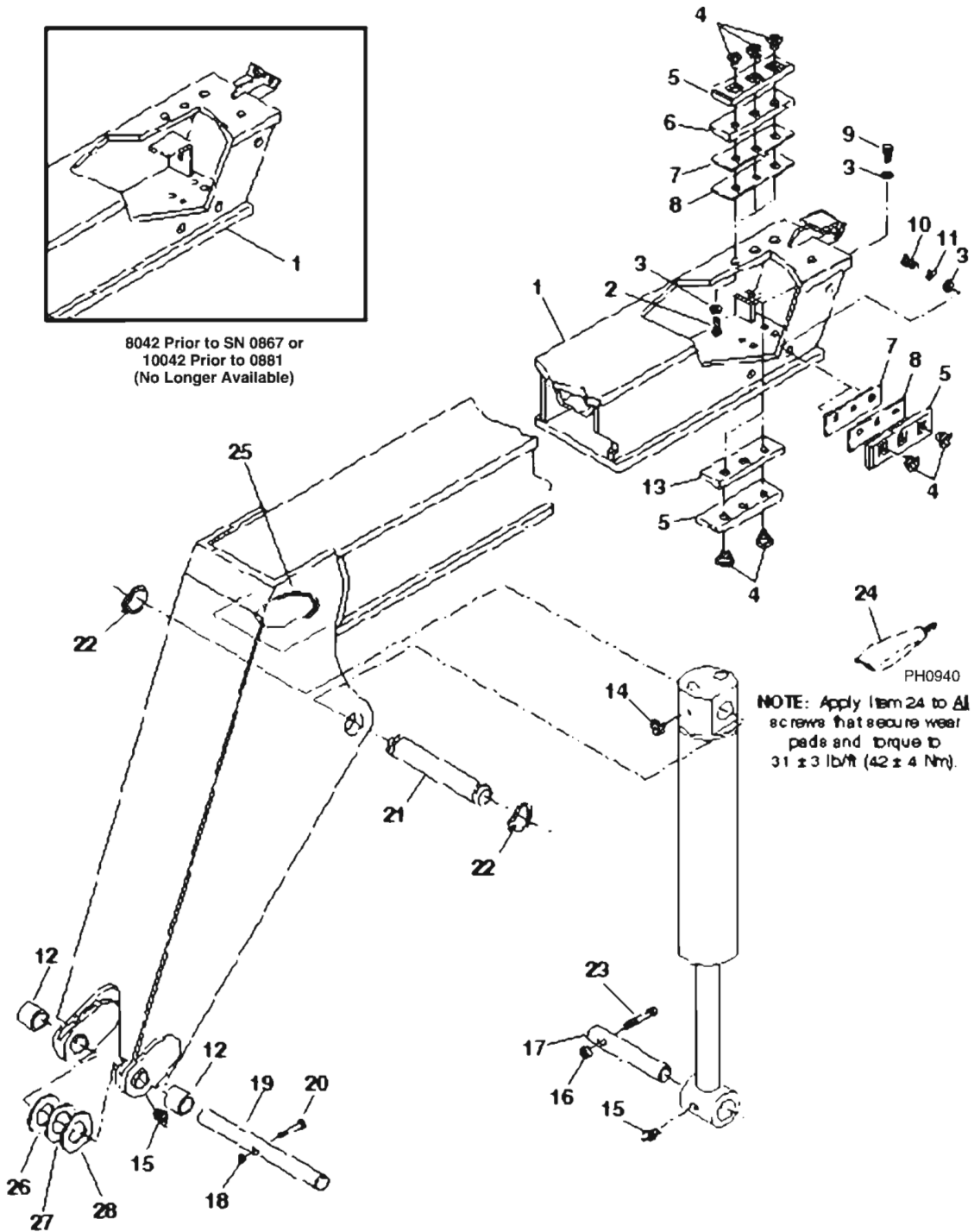

PH0063

SECTION 9 - BOOM AND ATTACHMENTS

FIGURE 9-3. INNER BOOM - 8042 & 10042

ITEM	PART NUMBER	QTY	DESCRIPTION	REV
1	7118662	1	Kit, Inner Boom, Includes bushings, chain links, hardware and chain clevis (8042 Prior to SN 0867; 10042 Prior to SN 0881)	
1	7117113	1	Inner Boom (8042 Prior to SN 0868; 10042 SN 0881 to Present)	
2	8303679	6	HHCS, 3/8-16 x 1-1/2in	
3	8307005	16	Washer, Lock 3/8in	
4	7082311	16	Insert, Wear Pad	
5	7111572	7	Wear Pad	
6	7096882	2	Spacer, Wear Pad, .62in	
7	7082362	AR	Shim, Wear Pad, .13in	
8	7082342	AR	Shim, Wear Pad, .07in	
9	8303675	2	HHCS, 3/8-16 x 1-1/4in	
10	8303681	8	HHCS, 3/8-16 x 3/4in	
11	8307204	8	Washer, Flat 3/8in	
12	7095312	2	Bushing, Quick Attach Pivot	
13	7096702	1	Spacer, Wear Pad, .50in	
14	8520021	1	Fitting, Lube, 1/8in 90	
15	8520013	3	Fitting, Lube, 1/8in Straight	
16	8305644	1	Nut, Hex Lock Elastic 1/2-13	
17	7083992	1	Pin, Attachment Tilt Cylinder (rod end)	
18	8305643	1	Nut, Hex Lock Elastic 5/8-11	
19	7095352	1	Pin, Pivot, Quick Attach	
20	8303666	1	HHCS, 5/8-11 x 5in	
21	7095522	1	Pin, Attachment Tilt Cylinder (base end)	
22	8642224	2	Ring, Retaining. 2in Dia	
23	8303772	1	HHCS, 1/2-13 x 5in	
24	8526036	AR	Tube, Thread Locking Compound .5cc	
25	7125811	1	Conduit, Plastic 3/4 x 8.00	
26	8307918	2	Washer, Shim 2.00 x 3.50 x 0.134	
27	8310093	AR	Washer, Shim 2.00 x 3.50 x 0.75	
28	8307904	AR	Washer, Shim 2.00 x 3.50 x 0.048	
1	7083054	1	Carriage, 48in	
2	8303634	2	HHCS, 5/8-11 x 4in	
3	7086471	2	Collar	
4	8305643	2	Nut, Hex Lock 5/8-11	
5	7118892	1	Pin, Lock (Includes Items 6 thru 8)	
6	7118882	1	Pin	
7	8310276	1	Washer, .51 x 1.88 x 1.25in	
8	8310266	1	Bolt, Eye 1/2 x 13 x 2in Length Shank	
9	7128772	1	Shaft, 48in	
10	7097523	2	Fork, Pallet 48in x 4in x 2in (4,000 lb Rating) - 8042 Only	
10	7097543	2	Fork, Pallet 48in x 4in x 2.25in (5,000 lb Rating) - 10042/10054 Only	
10	7097533	2	Fork, Lumber (Not Shown)	
10	7085073	6	Fork, Block (Not Shown)	
1	7086304	1	Carriage, 60in	
9	7128792	1	Shaft, 60in	
10	7097533	2	Fork, Lumber (Not Shown)	
10	7085073	6	Fork, Block (Not Shown)	
10	7097543	2	Fork, Pallet 48in x 4in x 2.25in (5,000 lb Rating) - 10042/10054 Only	
1	7089054	1	Carriage, Side Tilt - 60in	
1	7098354	1	Carriage, Side Tilt - 72in	

SECTION 9 - BOOM AND ATTACHMENTS

ITEM	PART NUMBER	QTY	DESCRIPTION	REV
1	7089044	1	Carriage, Side Tilt - 48in	
2	7065482	2	Pad, Wear	
3	8303739	2	HHCS, 5/16-18 x 1-1/4in	
4	8305626	2	Nut, Hex Lock 5/16-18	
5	Consult Factory	1	Base, Pivot	
6	7077501	1	Pin, Cyl Base	
7	7077511	1	Pin, Cyl Rod	
8	7077481	2	Spacer	
9	8065634	1	Bushing, Self Align	
10	8642001	1	Ring, Snap	
11	8642235	4	Ring, Snap	
12	8760117	2	Connector, Straight, SAE 6 - male JIC 37 x male str thd o-ring	
13	8584001	1	Tie Wrap	
14	2711992	2	Hose Assembly	
15	8760110	2	Connector, Straight, SAE 6-8 - male JIC 37 x male str thd o-ring	
16	8430006	1	Quick Disconnect, Male, SAE 8-8ORB - female internal (Includes Item 17)	
17	8640029	1	Seal, Nose (Not Shown)	
18	8430005	1	Quick Disconnect, Female, SAE 8-8ORB - female internal (Includes Items 19, 20 & 21)	
19	8640029	1	Seal, Nose (Not Shown)	
20	8640028	1	Seal, Coupler Body (Not Shown)	
21	8640032	1	Back-Up Ring, Coupler Body Seal (Not Shown)	
22	8541433	1	Plug, Pipe, Skt Hd - 1/8in NPTF	
23	8420053	1	Cap, Dust #8	
24	8420055	1	Plug, Dust #8	
25	7125741	1	Molding	
26	7085411	1	Pin, Pivot	
27	7085501	1	Collar, Pin Locking	
28	8303770	1	HHCS, 3/8-16 x 2-3/4in	
29	8305645	1	Nut, Hex Lock 3/8-16 ESNA	
30	7128772	1	Shaft, Fork Pivot 48in	
30	7128792	1	Shaft, Fork Pivot 60in	
30	7128802	1	Shaft, Fork Pivot 72in	
31	7086471	2	Hub, Lock	
32	8303634	2	HHCS, 5/8-11 x 4in	
33	8305643	2	Nut, Hex Lock 5/8-11	
34	7097523	2	Fork, Pallet 48in x 4in x 2in (4,000 lb Rating) - 8042 Only	
34	7097543	2	Fork, Pallet 48in x 4in x 2.25in (5,000 lb Rating) - 10042/10054 Only	
34	7097533	2	Fork, Lumber (Not Shown)	
34	7085073	6	Fork, Blocking (Not Shown)	
1	7117254	1	Carriage, Side Tilt - 60in	
1	7117264	1	Carriage, Side Tilt - 72in	
1	7117244	1	Carriage, Side Tilt - 48in	
5	7117204	1	Base, Pivot	
35	8307203	2	Washer, Flat Heavy	
36	7070191	AR	Shim	
37	4108232	1	Decal, Capacity Chart	
38	7119341	1	Plate, Capacity	
1	7111994	1	Carriage - 52in	
1	7110694	1	Carriage - 72in	
2	6608621	1	Cover - Clamp	

SECTION 9 - BOOM AND ATTACHMENTS

ITEM	PART NUMBER	QTY	DESCRIPTION	REV
3	8303715	3	HHCS, 5/16-18 x 1-1/2in	
4	7110702	2	Pin, Carriage Pivot	
5	7110494	1	Base, Pivot	
6	7110712	1	Pin, Cylinder Pivot (Rod End)	
7	7110722	2	Pin, Cylinder Pivot (Base End)	
8	8307918	AR	Shim, 2in I.D. x 10 Ga	
9	8065062	4	Bearing, Self Lube	
10	8307904	AR	Shim, 2in I.D. x 18 Ga	
11	8310161	AR	Shim, 1-1/2in I.D. x 10 Ga	
12	8760113	4	Connector, Straight, SAE 4 - male JIC 37 x male str thd o-ring	
13	8584001	4	Tie Wrap	
14	6604662	2	Hose Assembly	
15	8310160	AR	Shim, 1-1/2in I.D. x 18 Ga	
16	8430006	1	Quick Disconnect, Male, SAE 8-8ORB - female internal (Includes Item 17)	
17	8640029	1	Seal, Nose (Not Shown)	
18	8430005	1	Quick Disconnect, Female, SAE 8-8ORB - female internal (Includes Items 19, 20 & 21)	
19	8640029	1	Seal, Nose (Not Shown)	
20	8640028	1	Seal, Coupler Body (Not Shown)	
21	8640032	1	Back-Up Ring, Coupler Body Seal (Not Shown)	
22	7062922	1	Bearing, Thrust	
23	8420053	1	Cap, Dust #8	
24	8420055	1	Plug, Dust #8	
25	8642207	4	Ring, Retaining	
26	6611752	2	Hose Assembly	
27	8760313	2	Elbow, 90 SAE 6-8 - male JIC 37 x male str thd o-ring	
28	8760311	1	Elbow, 90 SAE 6 - male JIC 37 x male str thd o-ring	
29	8769132	2	Clamp, Half	
30	7128782	1	Shaft, Fork Pivot 52in	
30	7128802	1	Shaft, Fork Pivot 72in	
31	7086471	2	Hub, Lock	
32	8303634	5	HHCS, 5/8-11 x 4in	
33	8305643	5	Nut, Hex Lock 5/8-11	
34	7097523	2	Fork, Pallet 48in x 4in x 2in (4,000 lb Rating) - 8042 Only	
34	7097543	2	Fork, Pallet 48in x 4in x 2.25in (5,000 lb Rating) - 10042/10054 Only	
34	7097533	2	Fork, Lumber (Not Shown)	
34	7085073	6	Fork, Blocking (Not Shown)	
35	4107692	2	Chart, Capacity	
36	4107702	1	Decal, Danger - Tip Over Hazard	
37	8760409	2	Nut, SAE 6 - JIC 37	
38	8760475	2	Reducer, Tube End, SAE 6-4 - JIC 37	
39	8770012	1	Elbow, 90 SAE 6-4 - male JIC 37 x male str thd o-ring	
40	8770016	1	Reducer, SAE 4-6 - male str thd o-ring x female internal o-ring boss	
41	4107712	1	Decal, Danger - No Truss Boom	
42	8580315	2	Plug, Trim 2-1/2in Dia	
1	7112533	1	Fork Support, Right Side	
2	7112523	1	Fork Support, Left Side	
3	7112642	2	Backrest Extension, Top	
4	8303626	6	HHCS, 1/2-13 x 1-1/2in	
5	8307007	6	Washer, Lock 1/2in	
6	8305012	4	Nut, Hex 1/2-13	

SECTION 9 - BOOM AND ATTACHMENTS

ITEM	PART NUMBER	QTY	DESCRIPTION	REV
7	8301456	2	Hitch Pin	
8	7114941	2	Lock Bar	
9	8305644	2	Nut, Hex Lock Elastic 1/2-13	
10	8307112	2	Washer, Flat 1/2in LT	

SECTION 9 - BOOM AND ATTACHMENTS

FIGURE 9-4. QUICK ATTACH

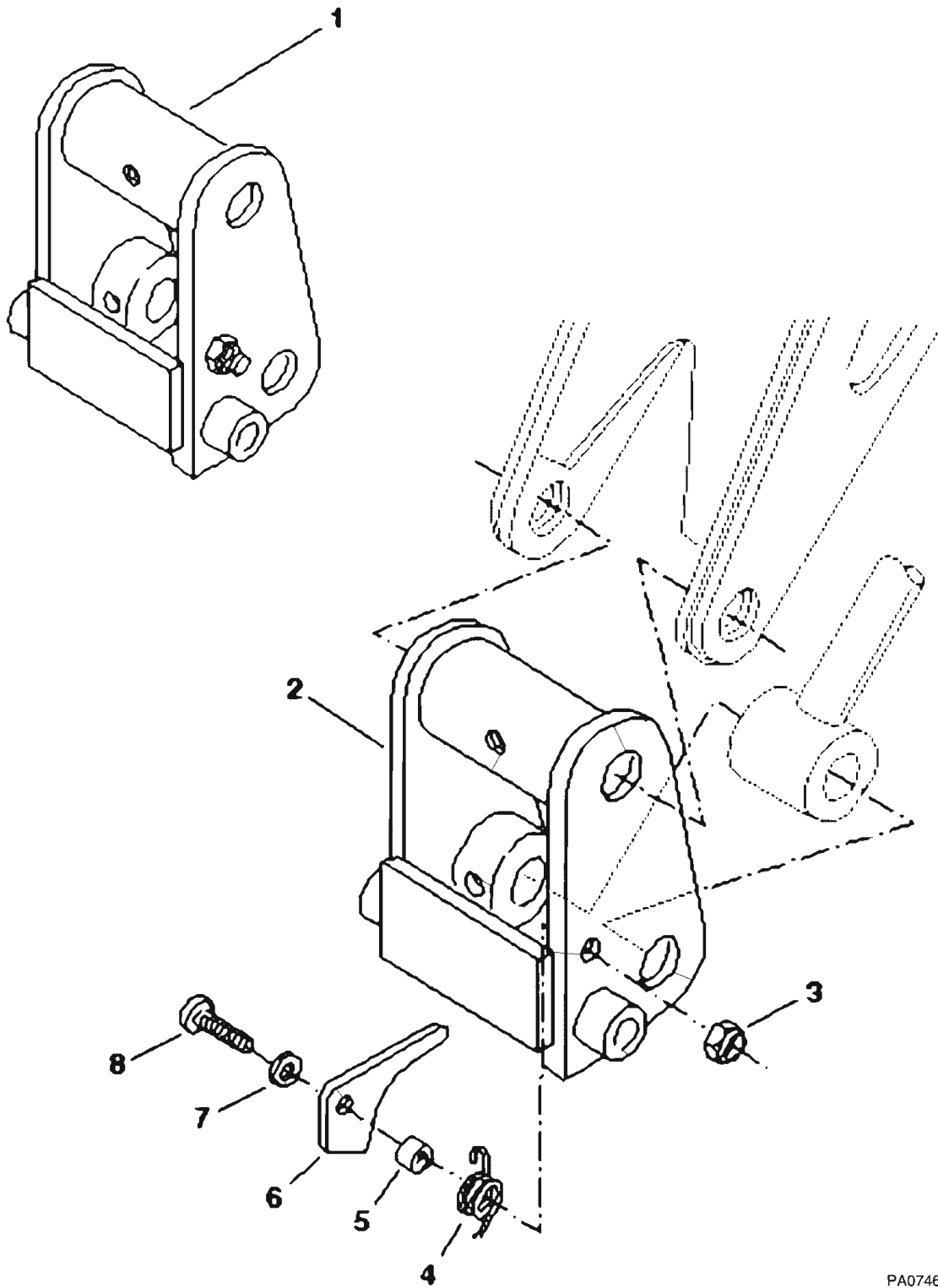

PA0746

SECTION 9 - BOOM AND ATTACHMENTS

FIGURE 9-4. QUICK ATTACH

ITEM	PART NUMBER	QTY	DESCRIPTION	REV
1	7085102	1	Quick Attach Assembly (Includes Items 2 thru 8)	
2	7120742	1	Quick Attach	
3	8305619	1	Nut, Hex Lock 3/4-10	
4	7085552	1	Spring, Torsion	
5	7085571	1	Spacer	
6	7085562	1	Latch	
7	8307104	1	Washer, Flat 3/4in	
8	8303638	1	HHCS, 3/4-10 x 2-3/4in	

SECTION 9 - BOOM AND ATTACHMENTS

FIGURE 9-5. CARRIAGE 48IN

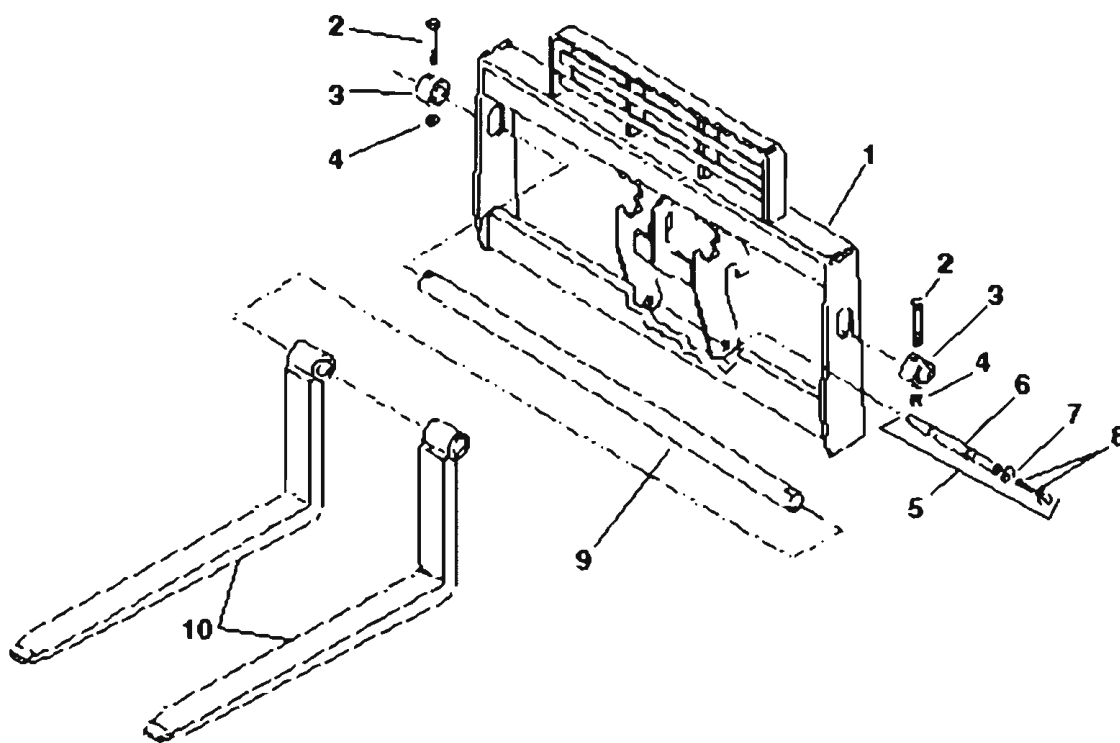

PA0744

SECTION 9 - BOOM AND ATTACHMENTS

FIGURE 9-5. CARRIAGE 48IN

ITEM	PART NUMBER	QTY	DESCRIPTION	REV
1	7083054	1	Carriage, 48in	
2	8303634	2	HHCS, 5/8-11 x 4in	
3	7086471	2	Collar	
4	8305643	2	Nut, Hex Lock 5/8-11	
5	7118892	1	Pin, Lock (Includes Items 6 thru 8)	
6	7118882	1	Pin	
7	8310276	1	Washer, .51 x 1.88 x 1.25in	
8	8310266	1	Bolt, Eye 1/2 x 13 x 2in Length Shank	
9	7128772	1	Shaft, 48in	
10	7097523	2	Fork, Pallet 48in x 4in x 2in (4,000 lb Rating) - 8042 Only	
10	7097543	2	Fork, Pallet 48in x 4in x 2.25in (5,000 lb Rating) - 10042/10054 Only	
10	7097533	2	Fork, Lumber (Not Shown)	
10	7085073	6	Fork, Block (Not Shown)	

SECTION 9 - BOOM AND ATTACHMENTS

FIGURE 9-6. CARRIAGE 60IN

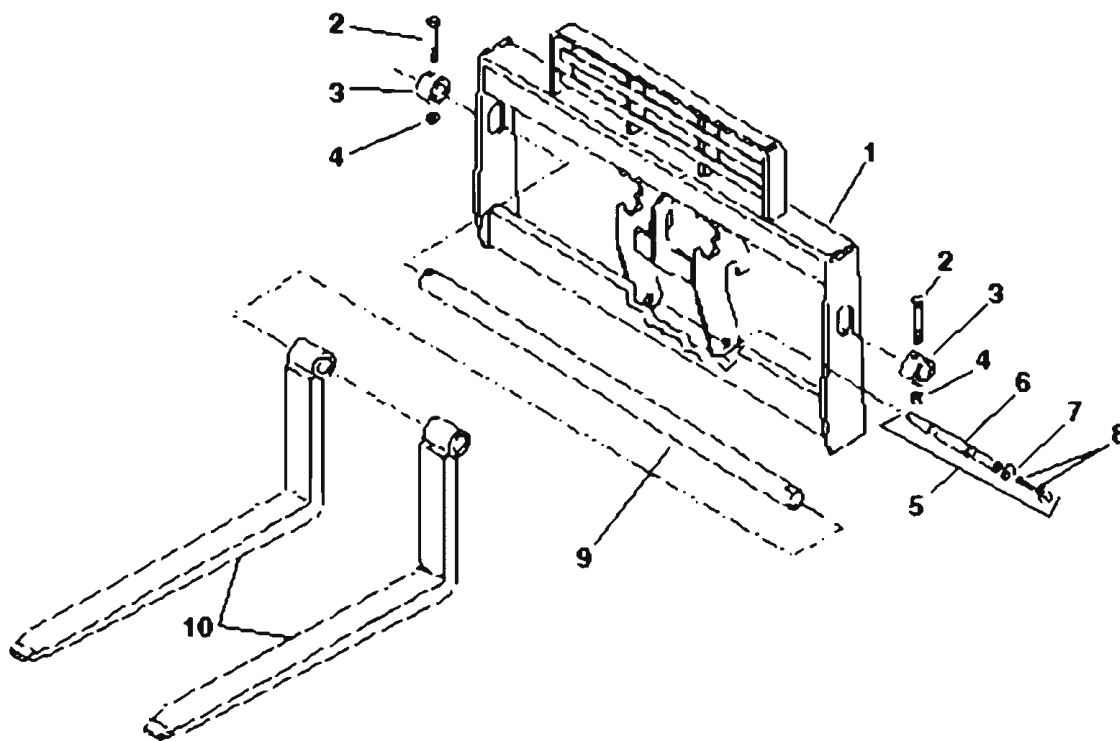

PA0744

SECTION 9 - BOOM AND ATTACHMENTS

FIGURE 9-6. CARRIAGE 60IN

ITEM	PART NUMBER	QTY	DESCRIPTION	REV
1	7086304	1	Carriage, 60in	
2	8303634	2	HHCS, 5/8-11 x 4in	
3	7086471	2	Collar	
4	8305643	2	Nut, Hex Lock 5/8-11	
5	7118892	1	Pin, Lock (Includes Items 6 thru 8)	
6	7118882	1	Pin	
7	8310276	1	Washer, .51 x 1.88 x 1.25in	
8	8310266	1	Bolt, Eye 1/2 x 13 x 2in Length Shank	
9	7128792	1	Shaft, 60in	
10	7097523	2	Fork, Pallet 48in x 4in x 2in (4,000 lb Rating) - 8042 Only	
10	7097543	2	Fork, Pallet 48in x 4in x 2.25in (5,000 lb Rating) - 10042/10054 Only	
10	7097533	2	Fork, Lumber (Not Shown)	
10	7085073	6	Fork, Block (Not Shown)	

SECTION 9 - BOOM AND ATTACHMENTS

FIGURE 9-7. CARRIAGE 72IN

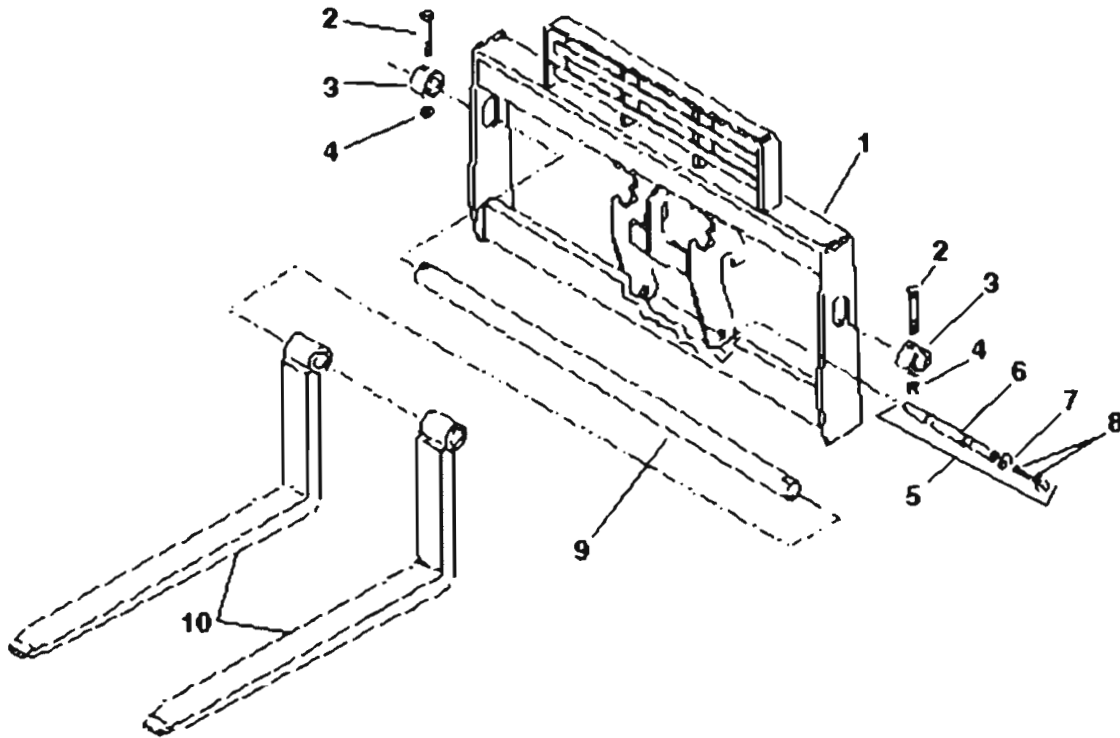

PA0744

SECTION 9 - BOOM AND ATTACHMENTS

FIGURE 9-7. CARRIAGE 72IN

ITEM	PART NUMBER	QTY	DESCRIPTION	REV
1	7090814	1	Carriage, 72in	
2	8303634	2	HHCS, 5/8-11 x 4in	
3	7086471	2	Collar	
4	8305643	2	Nut, Hex Lock 5/8-11	
5	7118892	1	Pin, Lock (Includes Items 6 thru 8)	
6	7118882	1	Pin	
7	8310276	1	Washer, .51 x 1.88 x 1.25in	
8	8310266	1	Bolt, Eye 1/2 x 13 x 2in Length Shank	
9	7128802	1	Shaft, 72in	
10	7097523	2	Fork, Pallet 48in x 4in x 2in (4,000 lb Rating) - 8042 Only	
10	7097543	2	Fork, Pallet 48in x 4in x 2.25in (5,000 lb Rating) - 10042/10054 Only	
10	7097533	2	Fork, Lumber (Not Shown)	
10	7085073	6	Fork, Block (Not Shown)	

SECTION 9 - BOOM AND ATTACHMENTS

FIGURE 9-8. SIDE TILT CARRIAGE - EARLY PRODUCTION (OPTIONAL)

IMPORTANT:

There are two similar but distinctly different Side Tilt Carriages. Make sure you know which version you have before ordering replacement parts. All reference to the right or left side are given from the operator's seat looking forward. An "Early Production" Carriage has its hydraulic cylinder attached on the operator's left side. The "Current Production" Carriage has its hydraulic cylinder attached on the right side, out of the operator's line of sight.



CURRENT PRODUCTION

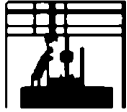

EARLY PRODUCTION

(VIEWED FROM OPERATOR'S SEAT LOCKING FORWARD)

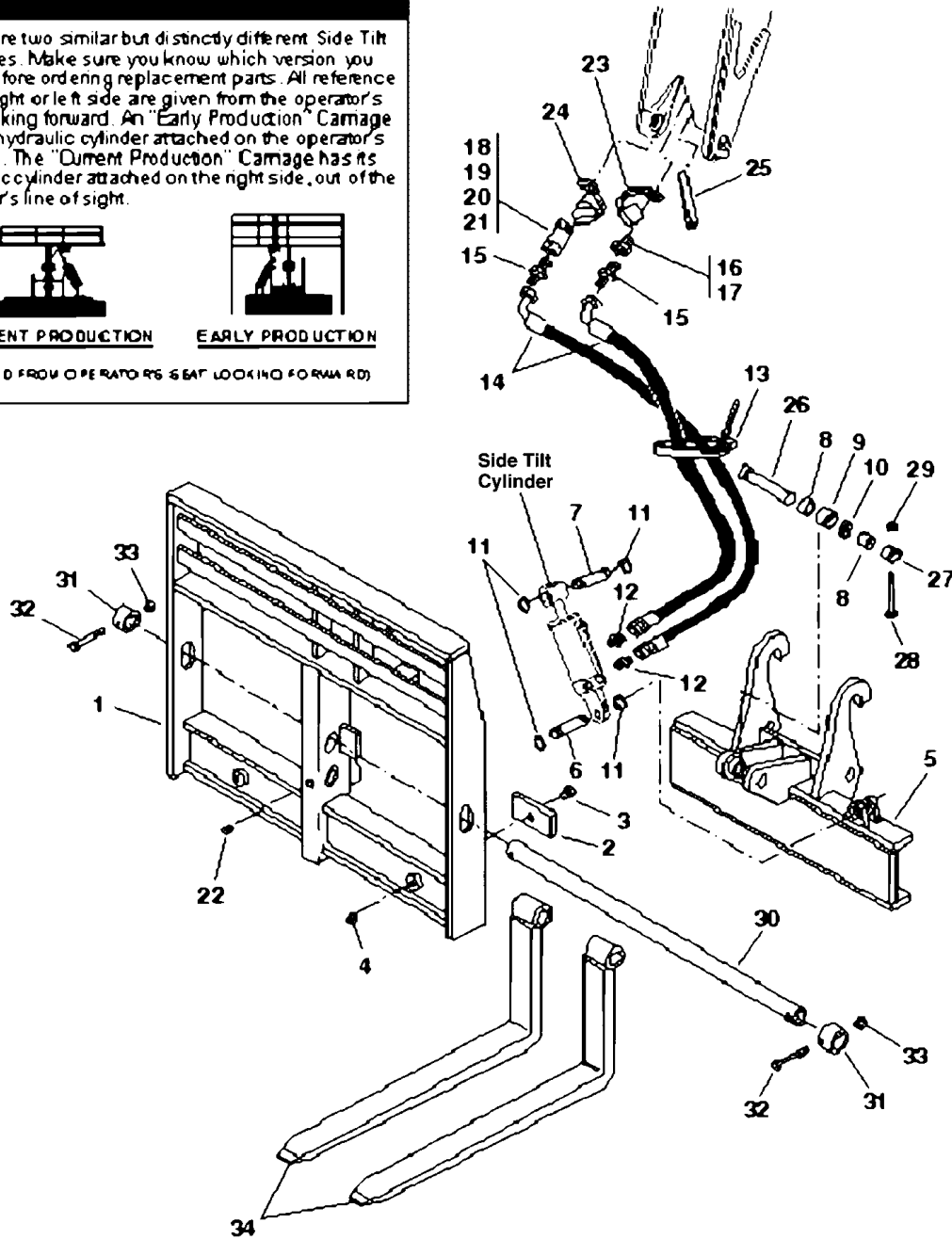

PA1153

SECTION 9 - BOOM AND ATTACHMENTS

FIGURE 9-8. SIDE TILT CARRIAGE - EARLY PRODUCTION (OPTIONAL)

ITEM	PART NUMBER	QTY	DESCRIPTION	REV
1	7089044	1	Carriage, Side Tilt - 48in	
1	7089054	1	Carriage, Side Tilt - 60in	
1	7098354	1	Carriage, Side Tilt - 72in	
2	7065482	2	Pad, Wear	
3	8303739	2	HHCS, 5/16-18 x 1-1/4in	
4	8305626	2	Nut, Hex Lock 5/16-18	
5	Consult Factory	1	Base, Pivot	
6	7077501	1	Pin, Cyl. Base	
7	7077511	1	Pin, Cyl. Rod	
8	7077481	2	Spacer	
9	8065634	1	Bushing, Self Align	
10	8642001	1	Ring, Snap	
11	8642235	4	Ring, Snap	
12	8760117	2	Connector, Straight, SAE 6 - male JIC 37 x male str thd o-ring	
13	8584001	1	Tie Wrap	
14	2711992	2	Hose Assembly	
15	8760110	2	Connector, Straight, SAE 6-8 - male JIC 37 x male str thd o-ring	
16	8430006	1	Quick Disconnect, Male, SAE 8-8ORB - female internal (Includes Item 17)	
17	8640029	1	Seal, Nose (Not Shown)	
18	8430005	1	Quick Disconnect, Female, SAE 8-8ORB - female internal (Includes Items 19, 20 & 21)	
19	8640029	1	Seal, Nose (Not Shown)	
20	8640028	1	Seal, Coupler Body (Not Shown)	
21	8640032	1	Back-Up Ring, Coupler Body Seal (Not Shown)	
22	8541433	1	Plug, Pipe, Skt. Hd - 1/8in NPTF	
23	8420053	1	Cap, Dust #8	
24	8420055	1	Plug, Dust #8	
25	7125741	1	Molding	
26	7085411	1	Pin, Pivot	
27	7085501	1	Collar, Pin Locking	
28	8303770	1	HHCS, 3/8-16 x 2-3/4in	
29	8305645	1	Nut, Hex Lock 3/8-16 ESNA	
30	7128772	1	Shaft, Fork Pivot 48in	
30	7128792	1	Shaft, Fork Pivot 60in	
30	7128802	1	Shaft, Fork Pivot 72in	
31	7086471	2	Hub, Lock	
32	8303634	2	HHCS, 5/8-11 x 4in	
33	8305643	2	Nut, Hex Lock 5/8-11	
34	7097523	2	Fork, Pallet 48in x 4in x 2in (4,000 lb Rating) - 8042 Only	
34	7097543	2	Fork, Pallet 48in x 4in x 2.25in (5,000 lb Rating) - 10042/10054 Only	
34	7097533	2	Fork, Lumber (Not Shown)	
34	7085073	6	Fork, Blocking (Not Shown)	

SECTION 9 - BOOM AND ATTACHMENTS

FIGURE 9-9. SIDE TILT CARRIAGE - CURRENT PRODUCTION (OPTIONAL)

IMPORTANT:

There are two similar but distinctly different Side Tilt Carriages. Make sure you know which version you have before ordering replacement parts. All reference to the right or left side are given from the operator's seat looking forward. An "Early Production" Carriage has its hydraulic cylinder attached on the operator's left side. The "Current Production" Carriage has its hydraulic cylinder attached on the right side, out of the operator's line of sight.



CURRENT PRODUCTION



EARLY PRODUCTION

(VIEWED FROM OPERATOR'S SEAT LOOKING FORWARD)

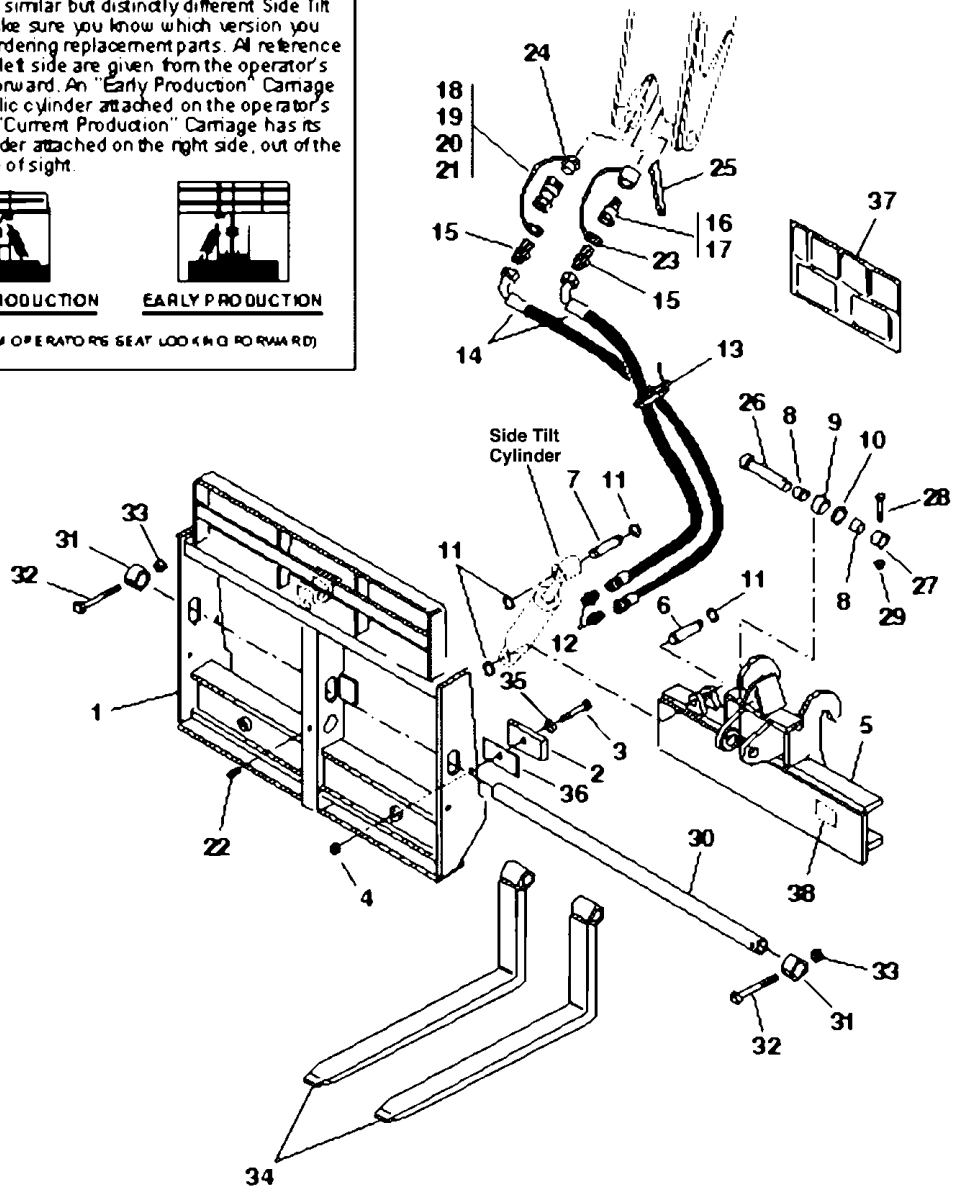

PA1591

SECTION 9 - BOOM AND ATTACHMENTS

FIGURE 9-9. SIDE TILT CARRIAGE - CURRENT PRODUCTION (OPTIONAL)

ITEM	PART NUMBER	QTY	DESCRIPTION	REV
1	7117244	1	Carriage, Side Tilt - 48in	
1	7117254	1	Carriage, Side Tilt - 60in	
1	7117264	1	Carriage, Side Tilt - 72in	
2	7065482	2	Pad, Wear	
3	8303739	2	HHCS, 5/16-18 x 1-1/4in	
4	8305626	2	Nut, Hex Lock 5/16-18	
5	7117204	1	Base, Pivot	
6	7077501	1	Pin, Cyl. Base	
7	7077511	1	Pin, Cyl. Rod	
8	7077481	2	Spacer	
9	8065634	1	Bushing, Self Align	
10	8642001	1	Ring, Snap	
11	8642235	4	Ring, Snap	
12	8760117	2	Connector, Straight, SAE 6 - male JIC 37 x male str thd o-ring	
13	8584001	1	Tie Wrap	
14	2711992	2	Hose Assembly	
15	8760110	2	Connector, Straight, SAE 6-8 - male JIC 37 x male str thd o-ring	
16	8430006	1	Quick Disconnect, Male, SAE 8-8ORB - female internal (Includes Item 17)	
17	8640029	1	Seal, Nose (Not Shown)	
18	8430005	1	Quick Disconnect, Female, SAE 8-8ORB - female internal (Includes Items 19, 20 & 21)	
19	8640029	1	Seal, Nose (Not Shown)	
20	8640028	1	Seal, Coupler Body (Not Shown)	
21	8640032	1	Back-Up Ring, Coupler Body Seal (Not Shown)	
22	8541433	1	Plug, Pipe, Skt. Hd - 1/8in NPTF	
23	8420053	1	Cap, Dust #8	
24	8420055	1	Plug, Dust #8	
25	7125741	1	Molding	
26	7085411	1	Pin, Pivot	
27	7085501	1	Collar, Pin Locking	
28	8303770	1	HHCS, 3/8-16 x 2-3/4in	
29	8305645	1	Nut, Hex Lock 3/8-16 ESNA	
30	7128772	1	Shaft, Fork Pivot 48in	
30	7128792	1	Shaft, Fork Pivot 60in	
30	7128802	1	Shaft, Fork Pivot 72in	
31	7086471	2	Hub, Lock	
32	8303634	2	HHCS, 5/8-11 x 4in	
33	8305643	2	Nut, Hex Lock 5/8-11	
34	7097523	2	Fork, Pallet 48in x 4in x 2in (4,000 lb Rating) - 8042 Only	
34	7097543	2	Fork, Pallet 48in x 4in x 2.25in (5,000 lb Rating) - 10042/10054 Only	
34	7097533	2	Fork, Lumber (Not Shown)	
34	7085073	6	Fork, Blocking (Not Shown)	
35	8307203	2	Washer, Flat Heavy	
36	7070191	AR	Shim	
37	4108232	1	Decal, Capacity Chart	
38	7119341	1	Plate, Capacity	

SECTION 9 - BOOM AND ATTACHMENTS

FIGURE 9-10. OUTRIGGERS (10042/10054 ONLY)

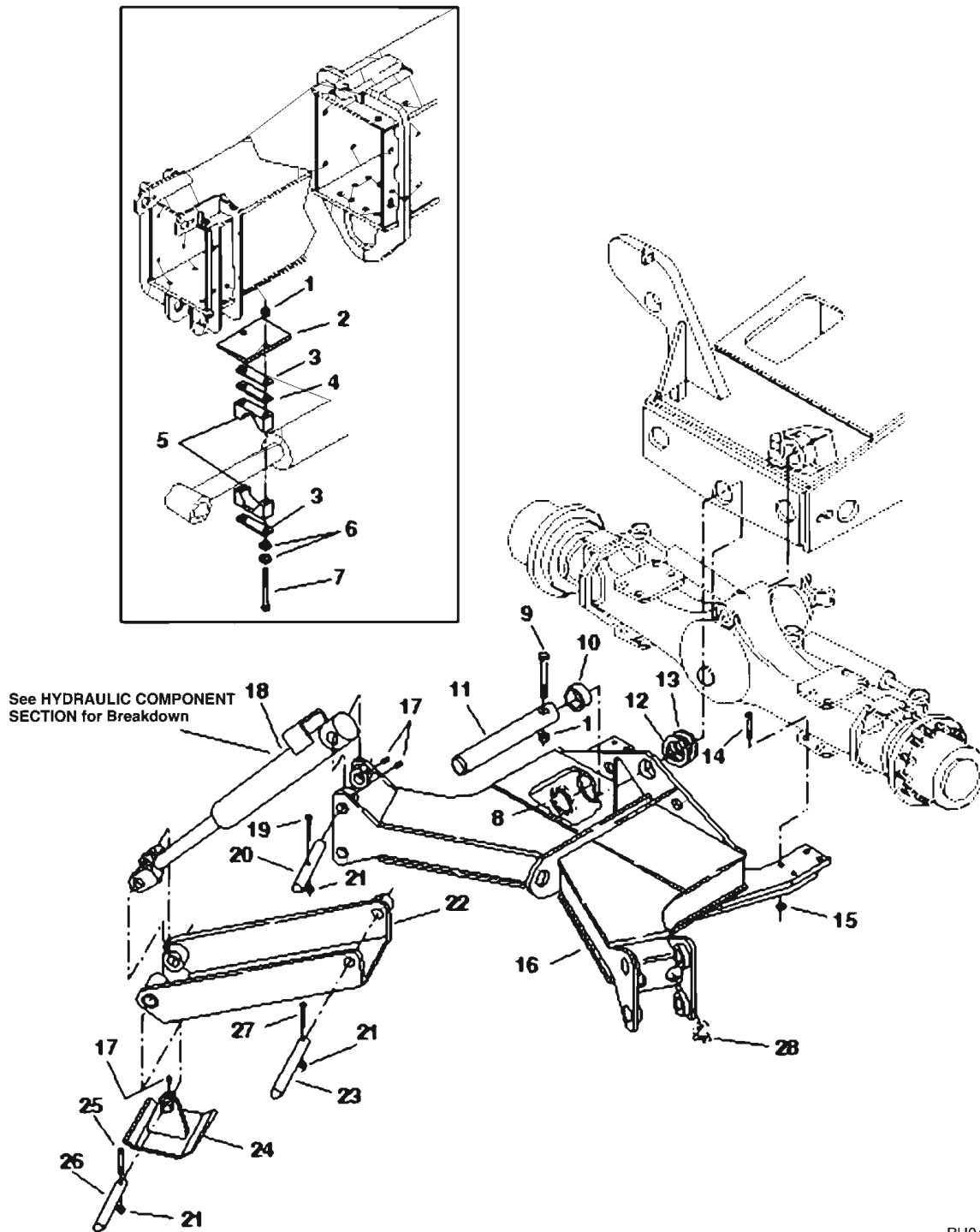

PH0402

SECTION 9 - BOOM AND ATTACHMENTS

FIGURE 9-10. OUTRIGGERS (10042/10054 ONLY)

ITEM	PART NUMBER	QTY	DESCRIPTION	REV
1	8305643	3	Nut, Hex Lock Elastic 5/8-11	
2	7115432	1	Plate, Boom Stop 5-1/4in Long (Prior to SN 0808)	
2	7110002	1	Plate, Boom Stop 12-1/4in Long (SN 0808 to Present)	
3	8769159	2	Cover Plate	
4	8769160	1	Safety Plate	
5	8769158	1	Clamp, Single 3in (2 Halves)	
6	8307107	AR	Washer, Flat 5/8in	
7	8303717	2	HHCS, 5/8-11 x 7-1/2in Grade 5	
8	7124491	2	Conduit, 1.0 I.D. x 15.5in	
9	8303655	1	HHCS, 5/8-11 x 4-1/2in Grade 5	
10	8065063	1	Bushing, 3in I.D. x 2in Long	
11	7090832	1	Pin, Axle Pivot	
12	8307912	1	Shim, 3.06 I.D. x .06in	
13	8307913	1	Shim, 3.06 I.D. x .12in	
14	8303794	8	HHCS, 3/4-10 x 3-1/2in Grade 8	
15	8310067	8	Nut, Hex Lock Elastic 3/4-10	
16	7090634	1	Frame, Outrigger	
17	8520013	10	Grease Fitting	
18	2716163	2	Cylinder, Outrigger	
19	8310151	2	HHCS, 1/2-13 x 7in Grade 5	
20	7090871	2	Pin, Cylinder Pivot	
21	8305644	6	Nut, Hex Lock Elastic 1/2-13	
22	7091373	2	Leg, Outrigger	
23	7090891	2	Pin, Leg Pivot	
24	7090822	2	Pad, Outrigger	
25	8303629	2	HHCS, 1/2-13 x 4-1/2in Grade 5	
26	7090951	2	Pin, Pad Pivot	
27	8303628	2	HHCS, 1/2-13 x 3-3/4in Grade 5	
28	7125801	4	Conduit, .75 I.D. x 4.0in	

SECTION 9 - BOOM AND ATTACHMENTS

FIGURE 9-11. SWING CARRIAGE (OPTIONAL)

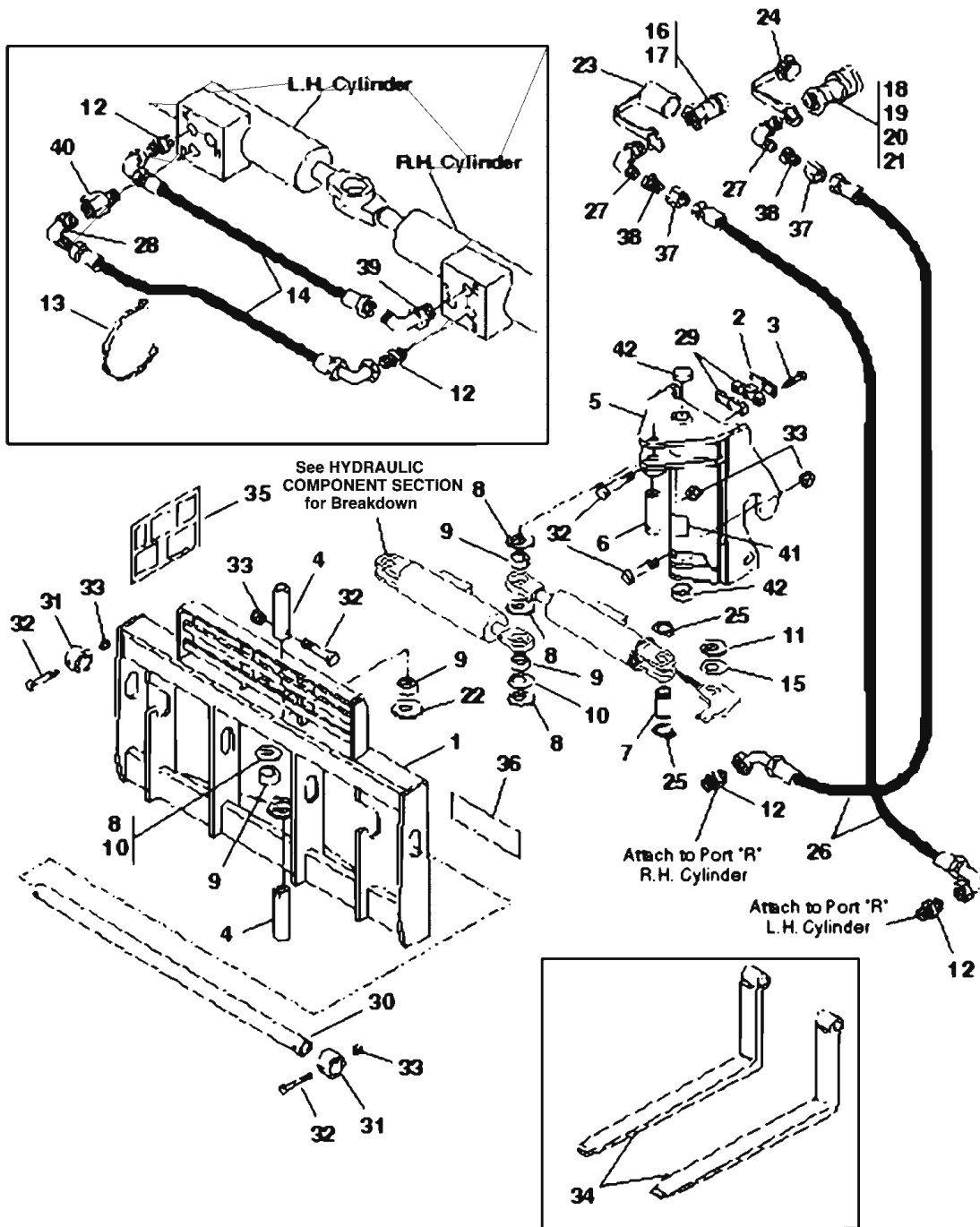

PH0560

SECTION 9 - BOOM AND ATTACHMENTS

FIGURE 9-11. SWING CARRIAGE (OPTIONAL)

ITEM	PART NUMBER	QTY	DESCRIPTION	REV
1	7111994	1	Carriage - 52in	
1	7110694	1	Carriage - 72in	
2	6608621	1	Cover - Clamp	
3	8303715	3	HHCS, 5/16-18 x 1-1/2in	
4	7110702	2	Pin, Carriage Pivot	
5	7110494	1	Base, Pivot	
6	7110712	1	Pin, Cylinder Pivot (Rod End)	
7	7110722	2	Pin, Cylinder Pivot (Base End)	
8	8307918	AR	Shim, 2in I.D. x 10 Ga	
9	8065062	4	Bearing, Self Lube	
10	8307904	AR	Shim, 2in I.D. x 18 Ga	
11	8310161	AR	Shim, 1-1/2in I.D. x 10 Ga	
12	8760113	4	Connector, Straight, SAE 4 - male JIC 37 x male str thd o-ring	
13	8584001	4	Tie Wrap	
14	6604662	2	Hose Assembly	
15	8310160	AR	Shim, 1-1/2in I.D. x 18 Ga	
16	8430006	1	Quick Disconnect, Male, SAE 8-8ORB - female internal (Includes Item 17)	
17	8640029	1	Seal, Nose (Not Shown)	
18	8430005	1	Quick Disconnect, Female, SAE 8-8ORB - female internal (Includes Items 19, 20 & 21)	
19	8640029	1	Seal, Nose (Not Shown)	
20	8640028	1	Seal, Coupler Body (Not Shown)	
21	8640032	1	Back-Up Ring, Coupler Body Seal (Not Shown)	
22	7062922	1	Bearing, Thrust	
23	8420053	1	Cap, Dust #8	
24	8420055	1	Plug, Dust #8	
25	8642207	4	Ring, Retaining	
26	6611752	2	Hose Assembly	
27	8760313	2	Elbow, 90, SAE 6-8 - male JIC 37 x male str thd o-ring	
28	8760311	1	Elbow, 90, SAE 6 - male JIC 37 x male str thd o-ring	
29	8769132	2	Clamp, Half	
30	7128782	1	Shaft, Fork Pivot 52in	
30	7128802	1	Shaft, Fork Pivot 72in	
31	7086471	2	Hub, Lock	
32	8303634	5	HHCS, 5/8-11 x 4in	
33	8305643	5	Nut, Hex Lock 5/8-11	
34	7097523	2	Fork, Pallet 48in x 4in x 2in (4,000 lb Rating) - 8042 Only	
34	7097543	2	Fork, Pallet 48in x 4in x 2.25in (5,000 lb Rating) - 10042/10054 Only	
34	7097533	2	Fork, Lumber (Not Shown)	
34	7085073	6	Fork, Blocking (Not Shown)	
35	4107692	2	Chart, Capacity	
36	4107702	1	Decal, Danger - Tip Over Hazard	
37	8760409	2	Nut, SAE 6 - JIC 37	
38	8760475	2	Reducer, Tube End, SAE 6-4 - JIC 37	
39	8770012	1	Elbow, 90, SAE 6-4 - male JIC 37 x male str thd o-ring	
40	8770016	1	Reducer, SAE 4-6 - male str thd o-ring x female internal o-ring boss	
41	4107712	1	Decal, Danger - No Truss Boom	
42	8580315	2	Plug, Trim 2-1/2in Dia	

SECTION 9 - BOOM AND ATTACHMENTS

FIGURE 9-12. SHEET MATERIAL HANDLER (OPTIONAL)

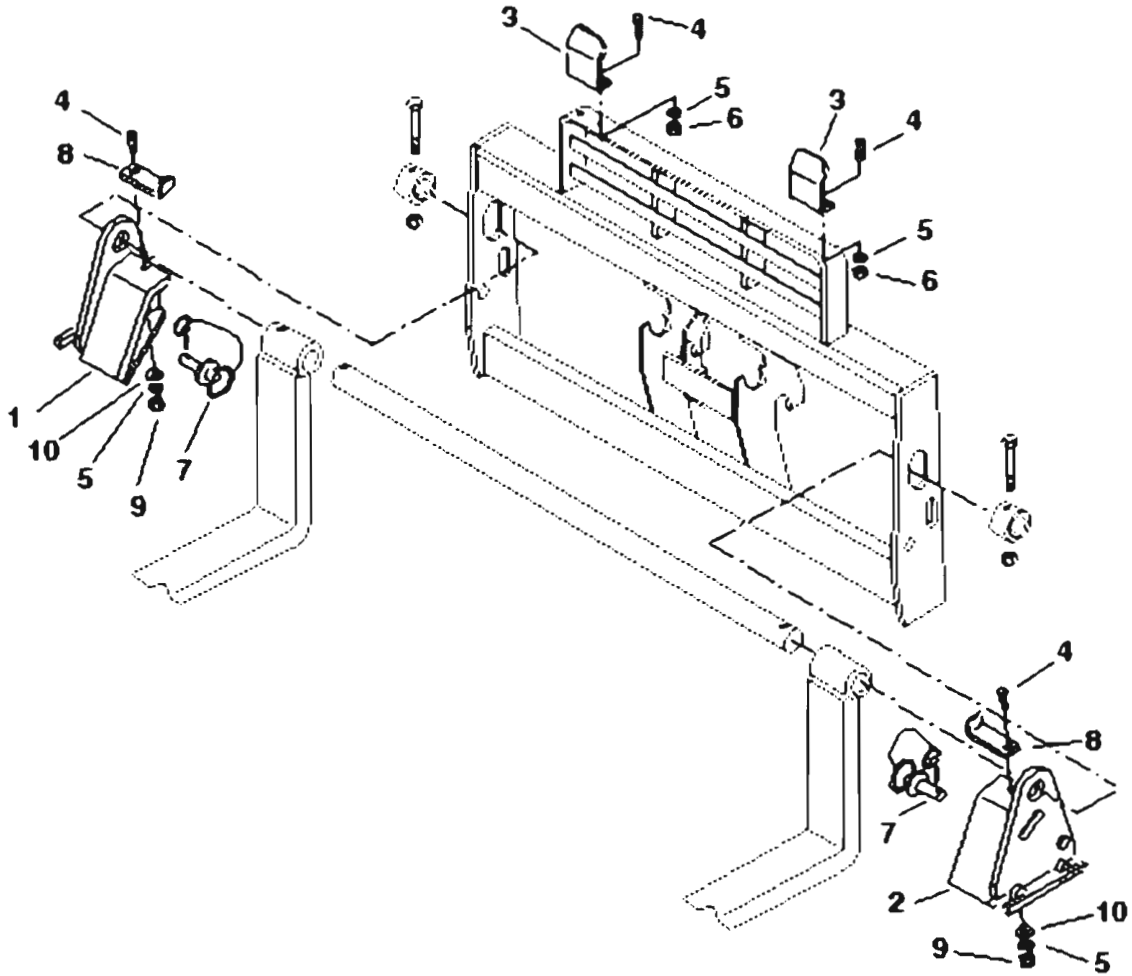

PK0042

SECTION 9 - BOOM AND ATTACHMENTS

FIGURE 9-12. SHEET MATERIAL HANDLER (OPTIONAL)

ITEM	PART NUMBER	QTY	DESCRIPTION	REV
1	7112533	1	Fork Support, Right Side	
2	7112523	1	Fork Support, Left Side	
3	7112642	2	Backrest Extension, Top	
4	8303626	6	HHCS, 1/2-13 x 1-1/2in	
5	8307007	6	Washer, Lock 1/2in	
6	8305012	4	Nut, Hex 1/2-13	
7	8301456	2	Hitch Pin	
8	7114941	2	Lock Bar	
9	8305644	2	Nut, Hex Lock Elastic 1/2-13	
10	8307112	2	Washer, Flat 1/2in LT	

SECTION 9 - BOOM AND ATTACHMENTS

FIGURE 9-13. UTILITY BUCKET (OPTIONAL)

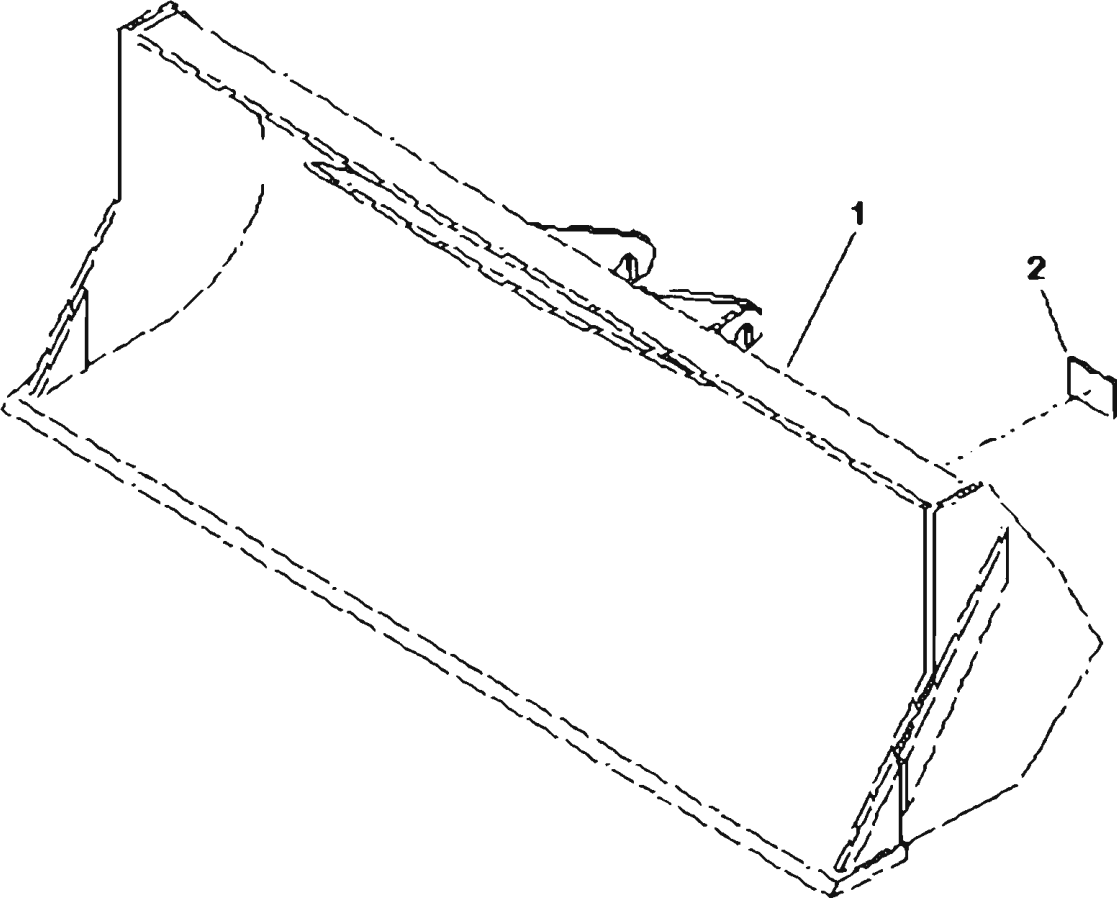

PA0782

SECTION 9 - BOOM AND ATTACHMENTS

FIGURE 9-13. UTILITY BUCKET (OPTIONAL)

ITEM	PART NUMBER	QTY	DESCRIPTION	REV
1	7110744	1	Bucket, Utility, 1-1/4 cu yd (Includes Item 2)	
2	4106561	1	Plate, Capacity	

SECTION 9 - BOOM AND ATTACHMENTS

FIGURE 9-14. PRIMARY INTERMEDIATE BOOM - 10054

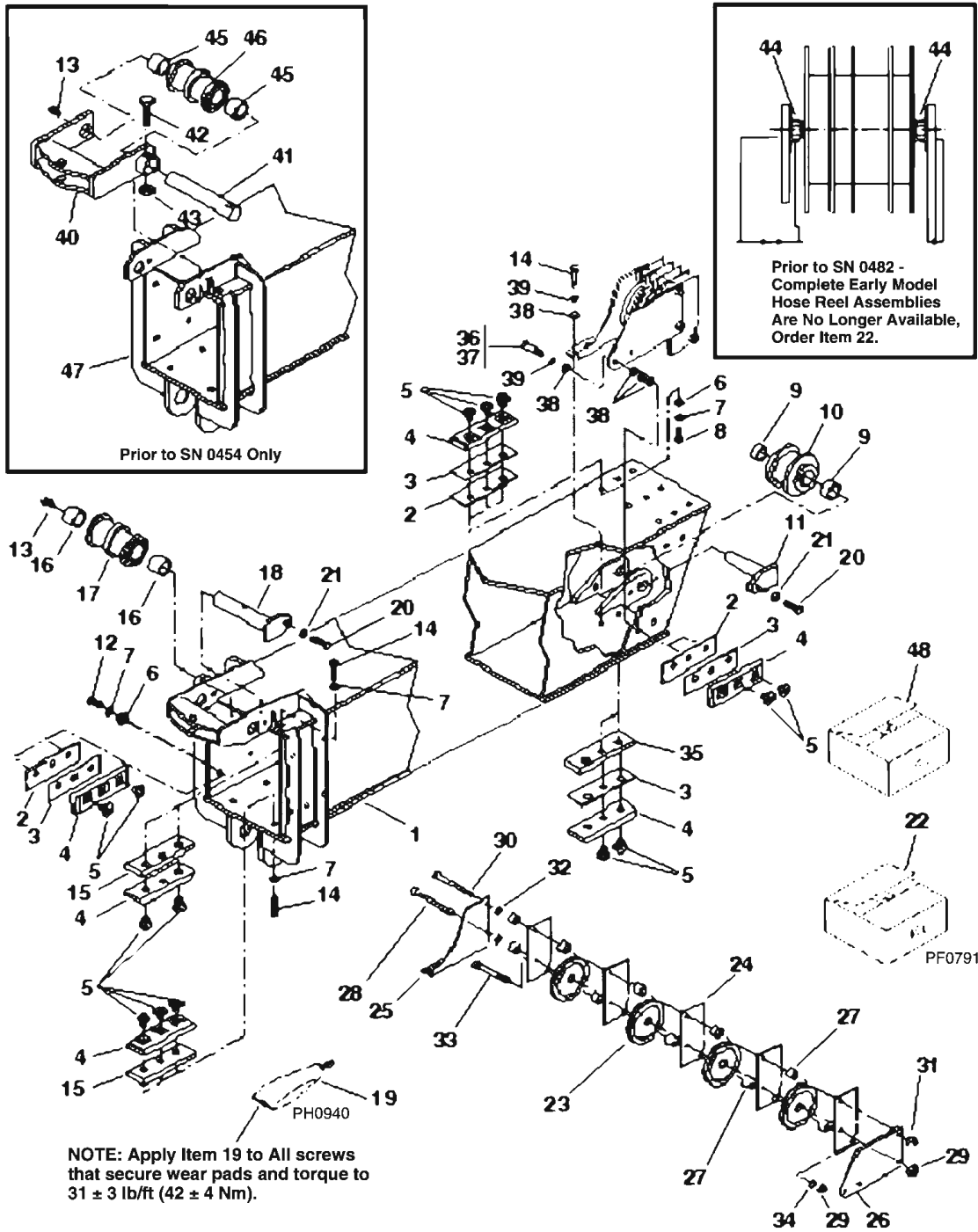

SECTION 9 - BOOM AND ATTACHMENTS

FIGURE 9-14. PRIMARY INTERMEDIATE BOOM - 10054

ITEM	PART NUMBER	QTY	DESCRIPTION	REV
1	7118854	1	Primary Intermediate Boom (SN 0454 to Present)	
2	7082362	AR	Shim, Wear Pad, (.13in thick)	
3	7082342	AR	Shim, Wear Pad (.075in thick)	
4	7111572	16	Wear Pad	
5	7082311	37	Insert, Wear Pad	
6	8307204	22	Washer, Flat 3/8in	
7	8307005	37	Washer, Lock 3/8in	
8	8303620	9	HHCS, 3/8-16 x 1in	
9	NLA	2	Bushing, Chain Sheave, For Service, Order Kit P/N 7138980	
10	NLA	1	Sheave, Retract Chain, For Service, Order Kit P/N 7138980	
11	NLA	1	Pin, Retract Chain Sheave, For Service, Order Kit P/N 7138980	
12	8303681	11	HHCS, 3/8-16 x 3/4in	
13	8520001	1	Fitting, Lube 1/8in Straight	
14	8303621	12	HHCS, 3/8-16 x 1-1/2in	
15	7096882	2	Spacer, Wear Pad .62in	
16	7126662	2	Bushing, Chain Sheave (SN 0454 to Present)	
17	7114112	1	Sheave, Extend Chain (SN 0454 to Present)	
18	7117572	1	Pin, Extend Chain Sheave (SN 0454 to Present)	
19	8526036	AR	Tube, Thread Locking Compound .5cc	
20	8303624	3	HHCS, 1/2-13 x 1in	
21	8307007	2	Washer, Lock 1/2in	
22	7117072	1	Kit, Hose Pulley (Includes Items 23 thru 39)	
23	7116812	4	Roller Pulley	
24	7116642	5	Divider	
25	7116652	1	Bracket, Right Side	
26	7116662	1	Bracket, Left Side	
27	7116691	10	Spacer	
28	8310235	1	Screw, Shoulder 1/2 x 5.00in	
29	8305645	2	Nut, Lock 3/8-16 Elastic	
30	8310209	1	HHCS, 1/2-13 x 6.00in	
31	8305644	1	Nut, Lock 1/2-13 Elastic	
32	8307206	2	Washer, Flat 1/2in Heavy (.109 thick)	
33	8310245	1	Screw, Shoulder 1/2 x 4.00in	
34	8307204	1	Washer, Flat 3/8in Heavy (.083 thick)	
35	7096702	2	Spacer, Wear Pad (1/2in thick)	
36	8303679	2	HHCS, 3/8 x 1.75in	
37	8303675	2	HHCS, 3/8 x 1.25in	
38	8307204	10	Washer, Flat 3/8in	
39	8307005	4	Washer, Lock 3/8in	
40	7110042	1	Yoke, Extend Chain (Prior to SN 0454)	
41	7117542	1	Pin, Extend Chain Sheave (Or: Order Kit 7117534 which includes greaseable sheave pins and bushings for both primary and secondary intermediate booms) (Prior to SN 0454)	
42	8303634	1	HHCS, 5/8-11 x 4in (Prior to SN 0454)	
43	8305643	1	Nut, Hex Lock ESNA 5/8-11 (Prior to SN 0454)	
44	8065214	2	Bearing, Mini Side Flange Mount (Prior to SN 0454)	
45	7117502	2	Bushing, Extend Chain Sheave (Prior to SN 0454)	
46	7114112	1	Sheave, Extend Chain (Prior to SN 0454)	
47	NLA	1	Primary Intermediate Boom (Order Items 1, 16 thru 22) (Prior to SN 0454)	

SECTION 9 - BOOM AND ATTACHMENTS

ITEM	PART NUMBER	QTY	DESCRIPTION	REV
48	7138980	Ref 1	KITS Kit, Retract Chain Sheave (Includes Items 9 thru 11, New Hardware for Rear Boom Cover and Instructions)	

SECTION 9 - BOOM AND ATTACHMENTS

FIGURE 9-15. SECONDARY INTERMEDIATE BOOM - 10054

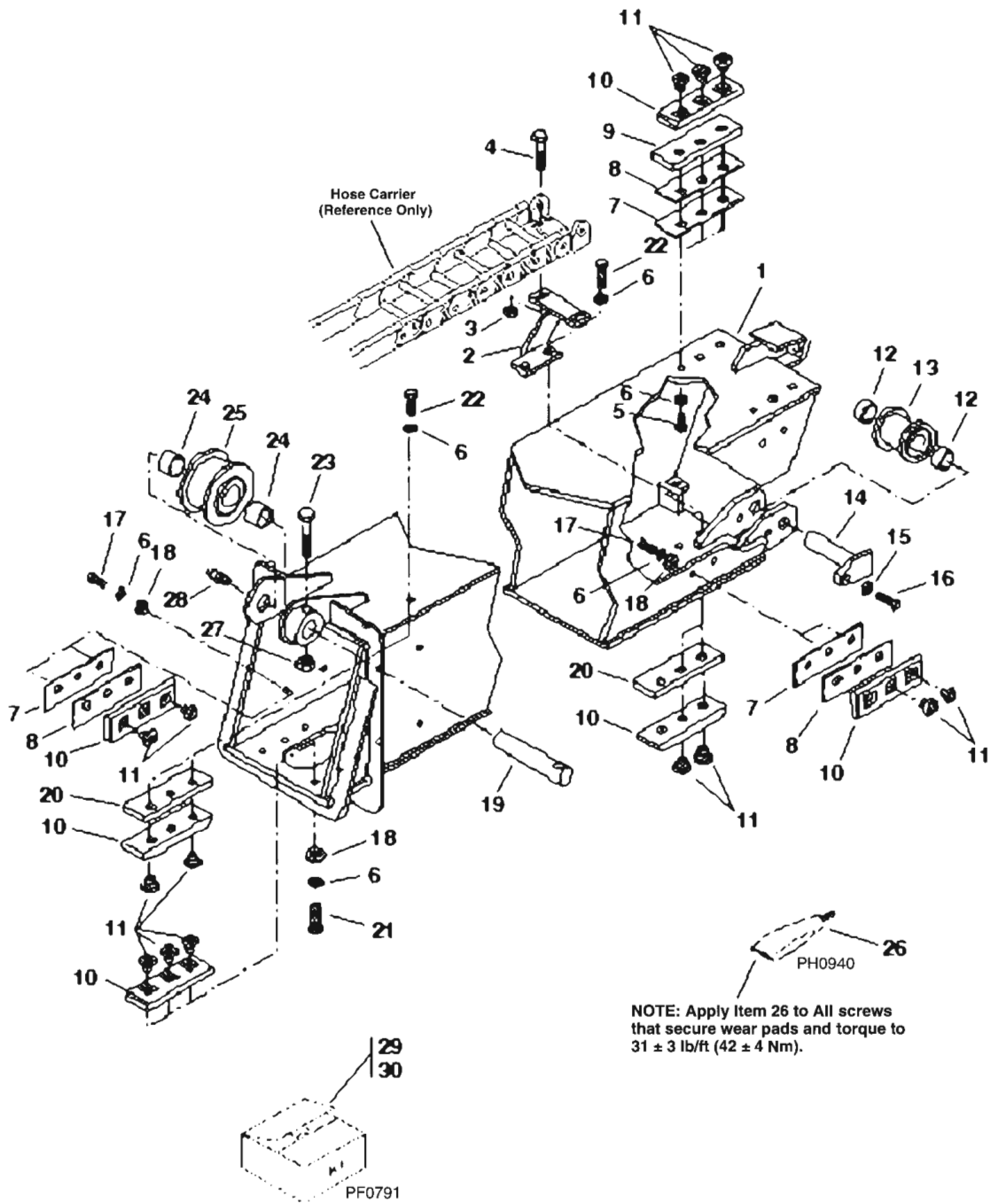

PH0683

SECTION 9 - BOOM AND ATTACHMENTS

FIGURE 9-15. SECONDARY INTERMEDIATE BOOM - 10054

ITEM	PART NUMBER	QTY	DESCRIPTION	REV
1	7117414	1	Secondary Intermediate Boom (Prior to SN 0885)	
1	7118692	1	Kit, Secondary Intermediate Boom includes clevis, link and hardware (SN 0885 to Present)	
2	7112732	1	Support, Hose Clamp	
3	8305624	4	Nut, Hex Lock ESNA 1/4-20	
4	8310026	4	HHCS, 1/4-20 x 3/4in	
5	8303679	6	HHCS, 3/8-16 x 1-3/4in	
6	8307005	34	Washer, Lock 3/8in	
7	7082362	AR	Shim, Wear Pad, (.13in thick)	
8	7082342	AR	Shim, Wear Pad, (.07in thick)	
9	7096882	2	Spacer, Wear Pad, .62in	
10	7111572	15	Wear Pad	
11	7082311	34	Insert, Wear Pad	
12	NLA	2	Bushing, Chain Sheave, For Service, Order Kit P/N 7138980	
13	NLA	1	Sheave, Retract Chain, For Service, Order Kit P/N 7138980	
14	NLA	1	Pin, Retract Chain Sheave, For Service, Order Kit P/N 7138980	
15	8307007	1	Washer, Lock 1/2in	
16	8303624	2	HHCS, 1/2-13 x 1in	
17	8303681	11	HHCS, 3/8-16 x 3/4in	
18	8307204	18	Washer, Flat 3/8in	
19	NLA	1	Pin, Extend Chain Sheave, For Service, Order Kit P/N 7117534 (Prior to SN 0454)	
19	7117582	1	Pin, Extend Chain Sheave (SN 0454 to Present)	
20	7096702	3	Spacer, Wear Pad .50in	
21	8303620	6	HHCS, 3/8-16 x 1in	
22	8303621	6	HHCS, 3/8-16 x 1-1/2in	
23	8303634	1	HHCS, 5/8-11 x 4in	
24	NLA	2	Bushing, Chain Sheave, For Service, Order Kit P/N 7117534 (Prior to SN 0454)	
24	7117502	2	Bushing, Chain Sheave (SN 0454 to Present)	
25	7114032	1	Sheave, Extend Chain	
26	8526036	AR	Tube, Thread Locking Compound .5cc	
27	8305643	1	Nut, Hex Lock ESNA 5/8-11	
28	8520001	1	Fitting, Lube 1/8in Straight	
		Ref	KITS	
29	7138980	1	Kit, Retract Chain Sheave (Includes Items 12 thru 14, New Hardware for Rear Boom Cover and Instructions)	
30	7117534	1	Kit, Extend Chain Sheave (includes greaseable sheave pins and bushings for both primary and secondary intermediate booms) (Prior to SN 0454)	

SECTION 9 - BOOM AND ATTACHMENTS

FIGURE 9-16. INNER BOOM - 10054

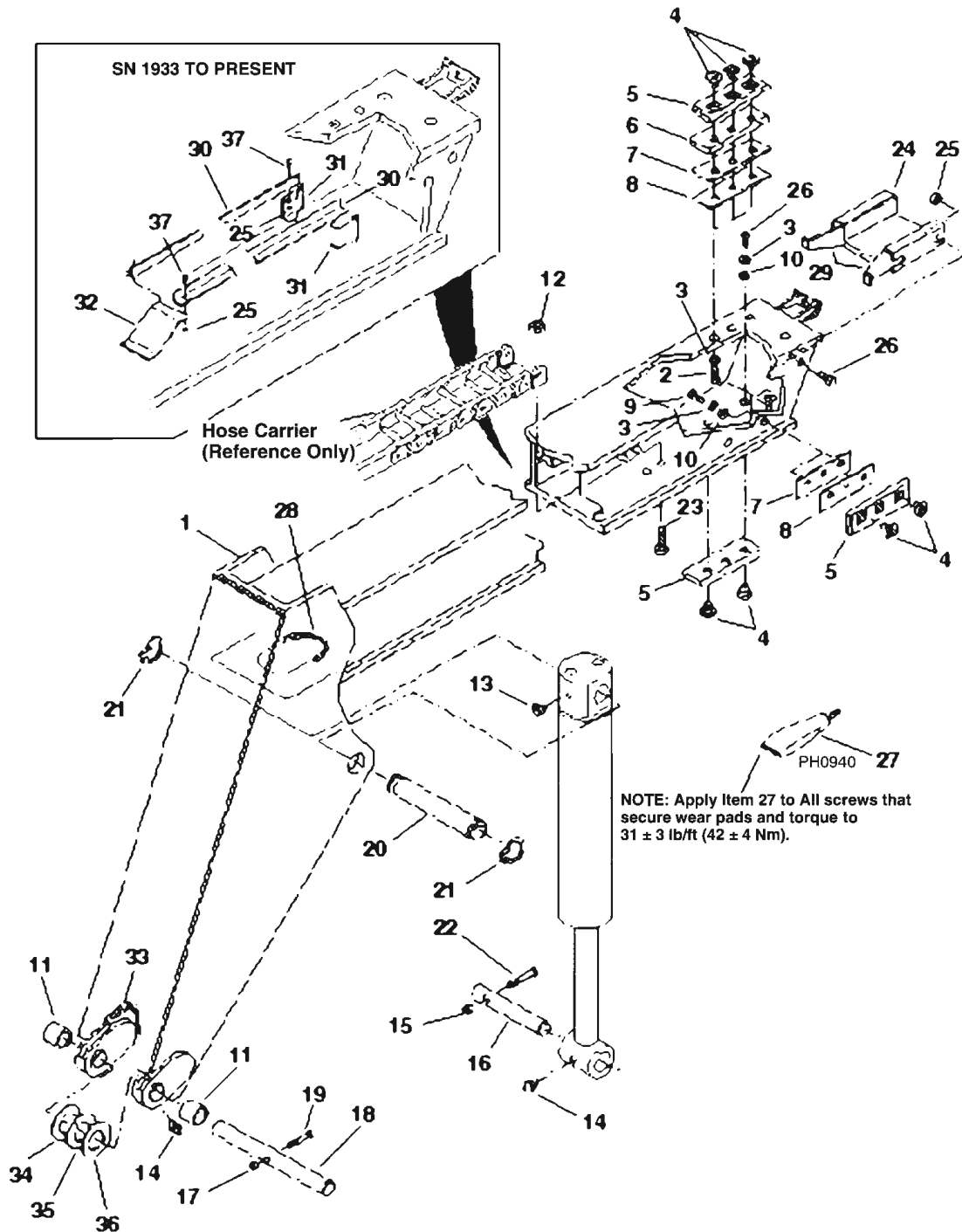

PH0662

SECTION 9 - BOOM AND ATTACHMENTS

FIGURE 9-16. INNER BOOM - 10054

ITEM	PART NUMBER	QTY	DESCRIPTION	REV
1	7118682	1	Kit, Inner Boom (includes bushings, chain links, hardware and chain clevis) (Prior to SN 0885)	
1	7117133	1	Inner Boom (SN 0885 to Present)	
2	8303621	6	HHCS, 3/8-16 x 1-1/2in	
3	8307005	16	Washer, Lock 3/8in	
4	7082311	16	Insert, Wear Pad	
5	7111572	7	Wear Pad	
6	7096702	2	Spacer, Wear Pad, .50in	
7	7082362	AR	Shim, Wear Pad, (.13in thick)	
8	7082342	AR	Shim, Wear Pad, (.07in thick)	
9	8303681	10	HHCS, 3/8-16 x 3/4in	
10	8307204	10	Washer, Flat 3/8in	
11	7095312	2	Bushing, Quick Attach Pivot	
12	8305624	4	Nut, Hex Lock ESNA 1/4-20	
13	8520021	1	Fitting, Lube, 1/8in 90	
14	8520013	3	Fitting, Lube, 1/8in Straight	
15	8305644	1	Nut, Hex Lock Elastic 1/2-13	
16	7083992	1	Pin, Attachment Tilt Cylinder (rod end)	
17	8305643	1	Nut, Hex Lock Elastic 5/8-11	
18	7095352	1	Pin, Pivot, Quick Attach	
19	8303666	1	HHCS, 5/8-11 x 5in	
20	7095522	1	Pin, Attachment Tilt Cylinder (base end)	
21	8642224	2	Ring, Retaining. 2in Dia	
22	8303772	1	HHCS, 1/2-13 x 5in	
23	8303540	4	HHCS, 1/4-20 x 1in	
24	7114922	1	Guide	
25	8305645	6	Nut, Hex Lock ESNA 3/8-16	
26	8303620	5	HHCS, 3/8-16 x 1in	
27	8526036	AR	Tube, Thread Locking Compound .5cc	
28	7125811	1	Conduit, Plastic 3/4 x 8.00	
29	5746411	2	Molding, 3.0in	
30	7110172	2	Hose Carrier, Guide (SN 1933 to Present)	
31	7127862	2	Guide Support, Rear (SN 1933 to Present)	
32	7127852	1	Guide Support, Front (SN 1933 to Present)	
33	7125741	1	Molding, Edge Protector	
34	8307918	2	Washer, Shim 2.00 x 3.50 x 0.134	
35	8310093	AR	Washer, Shim 2.00 x 3.50 x 0.075	
36	8307904	AR	Washer, Shim 2.00 x 3.50 x 0.048	
37	8303679	4	HHCS, 3/8-16 x 1.75	

SECTION 9 - BOOM AND ATTACHMENTS

FIGURE 9-17. BOOM EXTEND CHAINS - 8042 & 10042

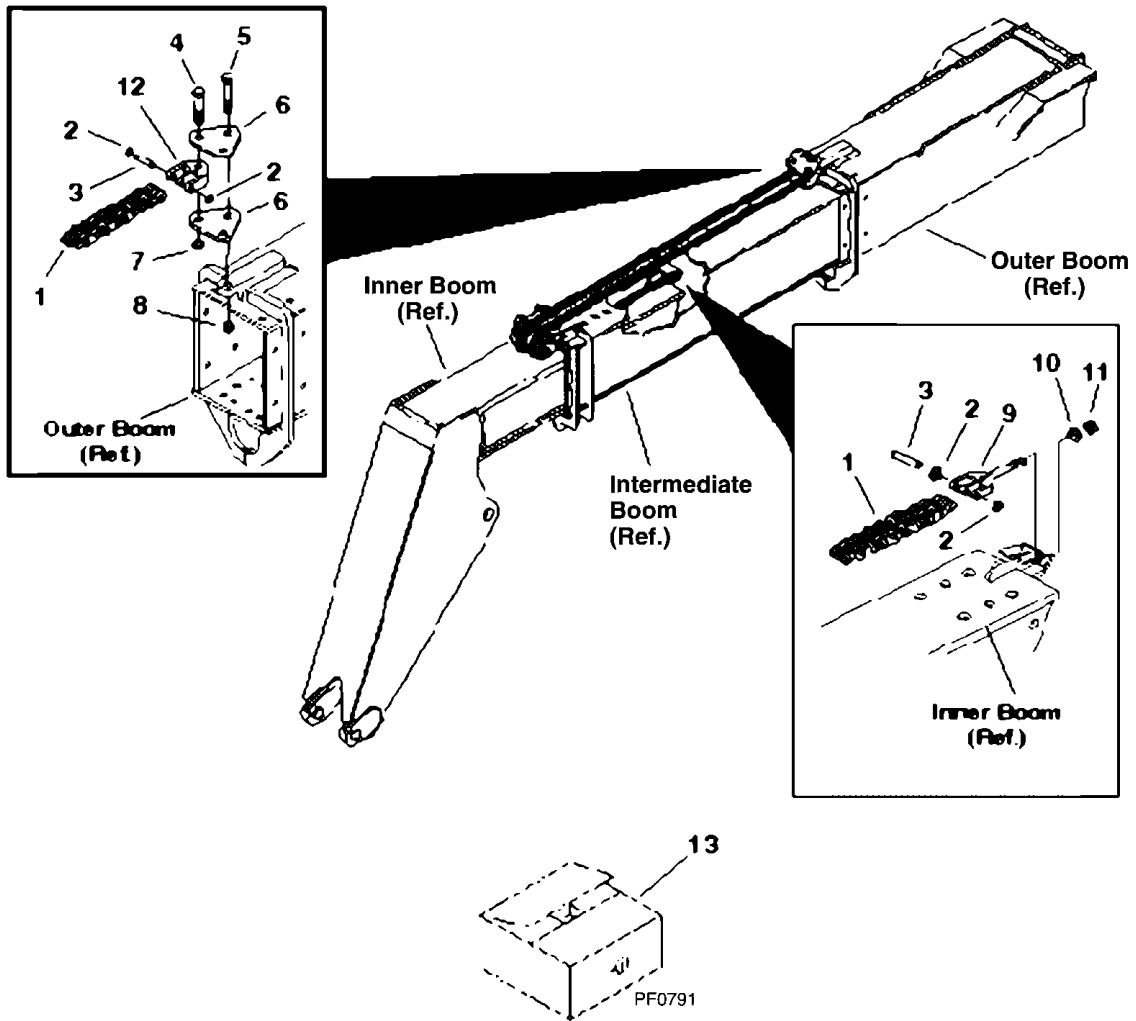

PH0821

SECTION 9 - BOOM AND ATTACHMENTS

FIGURE 9-17. BOOM EXTEND CHAINS - 8042 & 10042

ITEM	PART NUMBER	QTY	DESCRIPTION	REV
1	NLA	2	Chain, 4 x 6 Link - 194.25in Long (For Service, Order Kit P/N 7138738) (Prior to SN 11145)	
1	8127014	2	Chain, 6 x 6 Link (SN 11145 to Present)	
2	8642237	8	Retaining Ring, 1/4in Dia	
3	8124126	4	Pin, Chain Clevis	
4	8310019	2	Bolt, Shoulder 3/8-16 x 1-1/2in	
5	8310020	1	Bolt, Shoulder 1/2-13 x 1-1/2in	
6	7089781	2	Yoke, Extend Chain	
7	8305645	2	Nut, Hex Lock Elastic 3/8-16	
8	8305644	1	Nut, Hex Lock Elastic 1/2-13	
9	NLA	2	Clevis, 4 x 6 Chain (For Service, Order Kit P/N 7138738) (Prior to SN 11145)	
9	7119362	2	Clevis, 6 x 6 Chain (SN 11145 to Present)	
10	8307104	2	Washer, Flat 3/4in	
11	8305646	2	Nut, Hex Lock Elastic 3/4-16	
12	NLA	2	Clevis, 4 x 6 Chain (For Service, Order Kit P/N 7138738) (Prior to SN 11145)	
12	7119372	2	Clevis, 6 x 6 Chain (SN 11145 to Present)	
		Ref	KITS	
13	7138738	1	Kit, Extend Chain (Replaces 4 x 6 Link Chain with 6 x 6 Link Chain)	

SECTION 9 - BOOM AND ATTACHMENTS

FIGURE 9-18. BOOM RETRACT CHAIN - 8042 & 10042 (Prior to SN 1085)

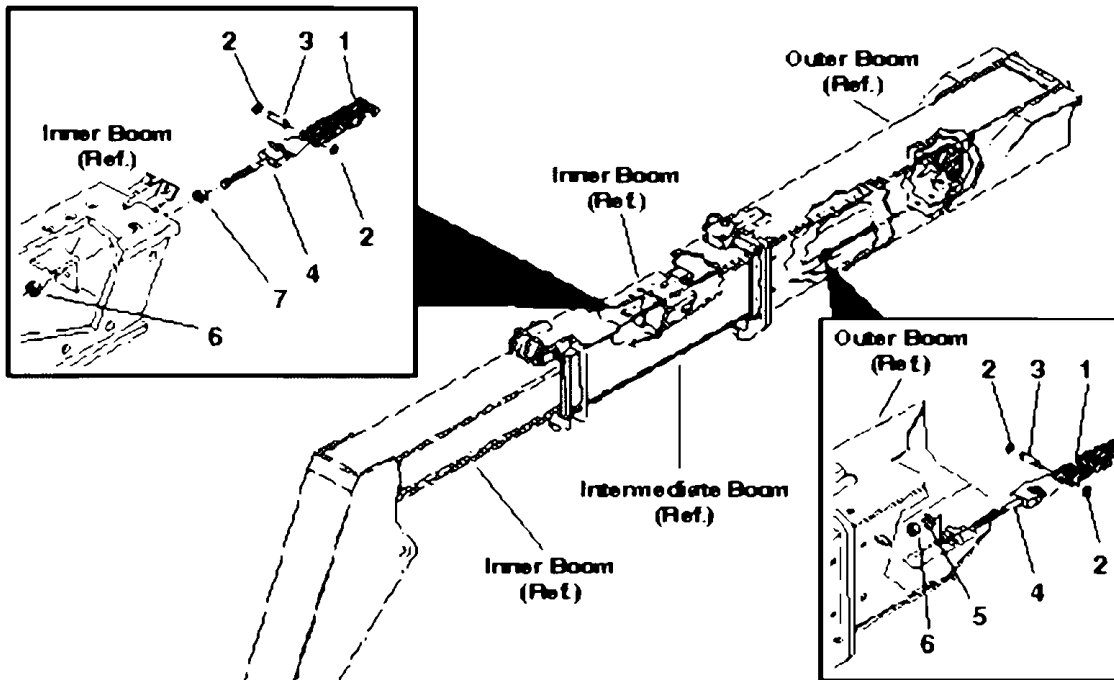

PH0851

SECTION 9 - BOOM AND ATTACHMENTS

FIGURE 9-18. BOOM RETRACT CHAIN - 8042 & 10042 (Prior to SN 1085)

ITEM	PART NUMBER	QTY	DESCRIPTION	REV
1	7120191	1	Kit, 6 x 6 Retract Chain (Includes 6 x 6 chain, 4 of Item 2, 2 of Item 3 & 2 of Item 4)	
2	8642237	4	Retaining Ring, 1/4in Dia	
3	8124126	2	Pin, Chain Clevis	
4	7119362	2	Clevis, 6 x 6 Chain	
5	8307104	1	Washer, Flat 3/4in	
6	8305646	2	Nut, Hex Lock Elastic 3/4-16	
7	8305018	1	Nut, Hex 3/4-16	

SECTION 9 - BOOM AND ATTACHMENTS

FIGURE 9-19. BOOM RETRACT CHAIN - 8042 & 10042 (SN 1085 through 13197)

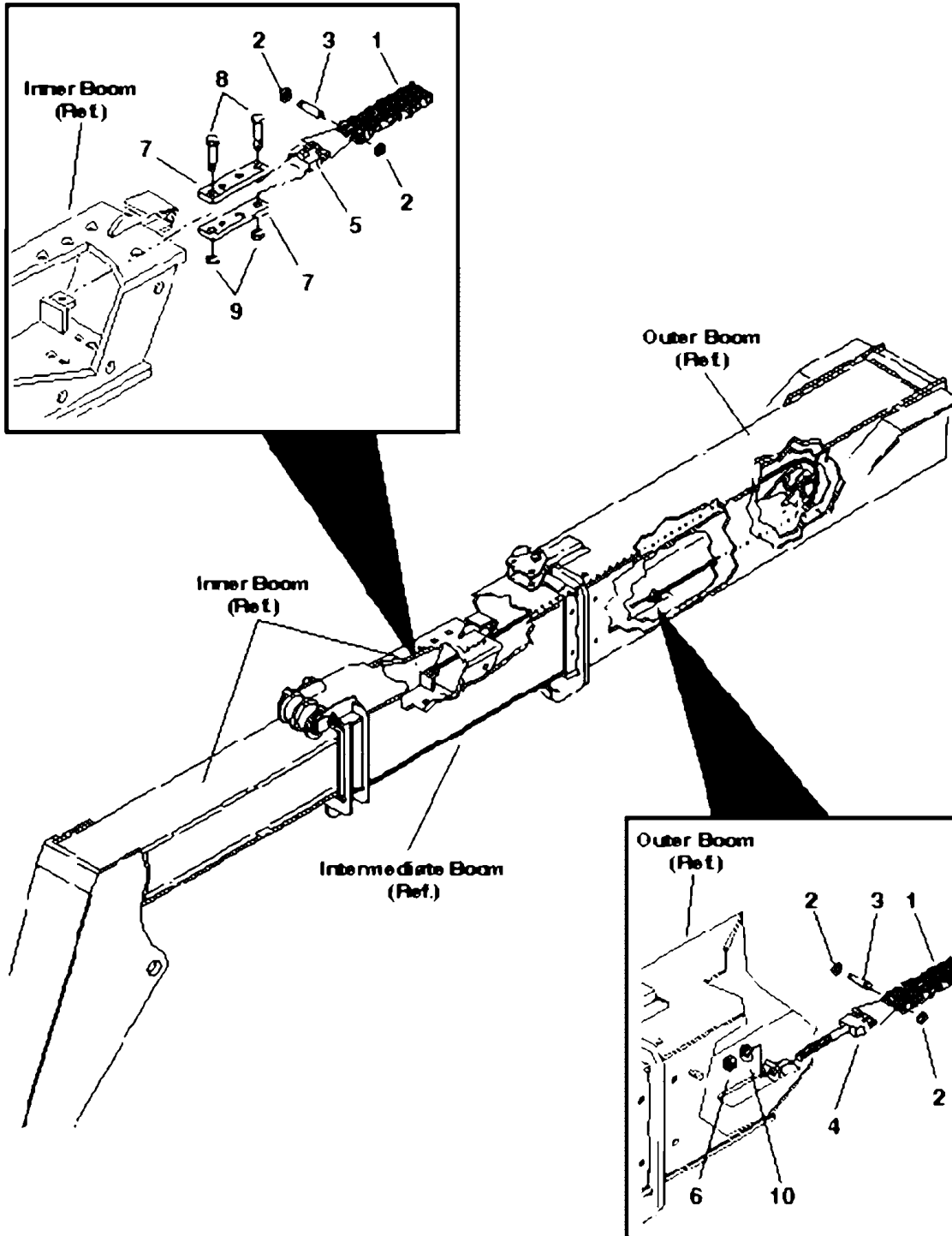

PH0831

SECTION 9 - BOOM AND ATTACHMENTS

FIGURE 9-19. BOOM RETRACT CHAIN - 8042 & 10042 (SN 1085 through 13197)

ITEM	PART NUMBER	QTY	DESCRIPTION	REV
1	7119351	1	Kit, 6 x 6 Retract Chain (Includes 6 x 6 chain, 4 of Item 2, 2 of Item 3, 1 Item 4 & 1 Item 5)	
2	8642237	4	Retaining Ring, 1/4in Dia	
3	8124126	2	Pin, Chain Clevis	
4	7119362	1	Clevis, 6 x 6 Chain	
5	7119372	1	Clevis, 6 x 6 Chain	
6	8305646	1	Nut, Hex Lock Elastic 3/4-16	
7	7117031	2	Link, Chain Anchor	
8	8310019	2	Bolt, Shoulder 1/2 x 1-1/2in	
9	8305645	2	Nut, Lock Elastic 3/8-16	
10	8307104	1	Washer, Flat 3/4in	
1	7112804	1	15ft Truss Boom - 10042 & 10054 (Includes Items 2 thru 9)	
1	7113024	1	12ft Truss Boom - 8042 (Includes Items 2 thru 9)	
2	8382017	1	Pintle Hook	
3	8310195	4	HHCS, 1/2-13 x 1.75in	
4	8307112	4	Washer, Plain 1/2 SAE	
5	8305644	4	Nut, Hex Lock Elastic 1/2-13	
6	4107182	2	Decal, Name	
7	4107822	2	Decal, Swinging Load	
8	4107832	2	Decal, Length/Capacity	
9	4107812	2	Chart, Capacity	

SECTION 9 - BOOM AND ATTACHMENTS

FIGURE 9-20. BOOM EXTEND CHAINS - 10054

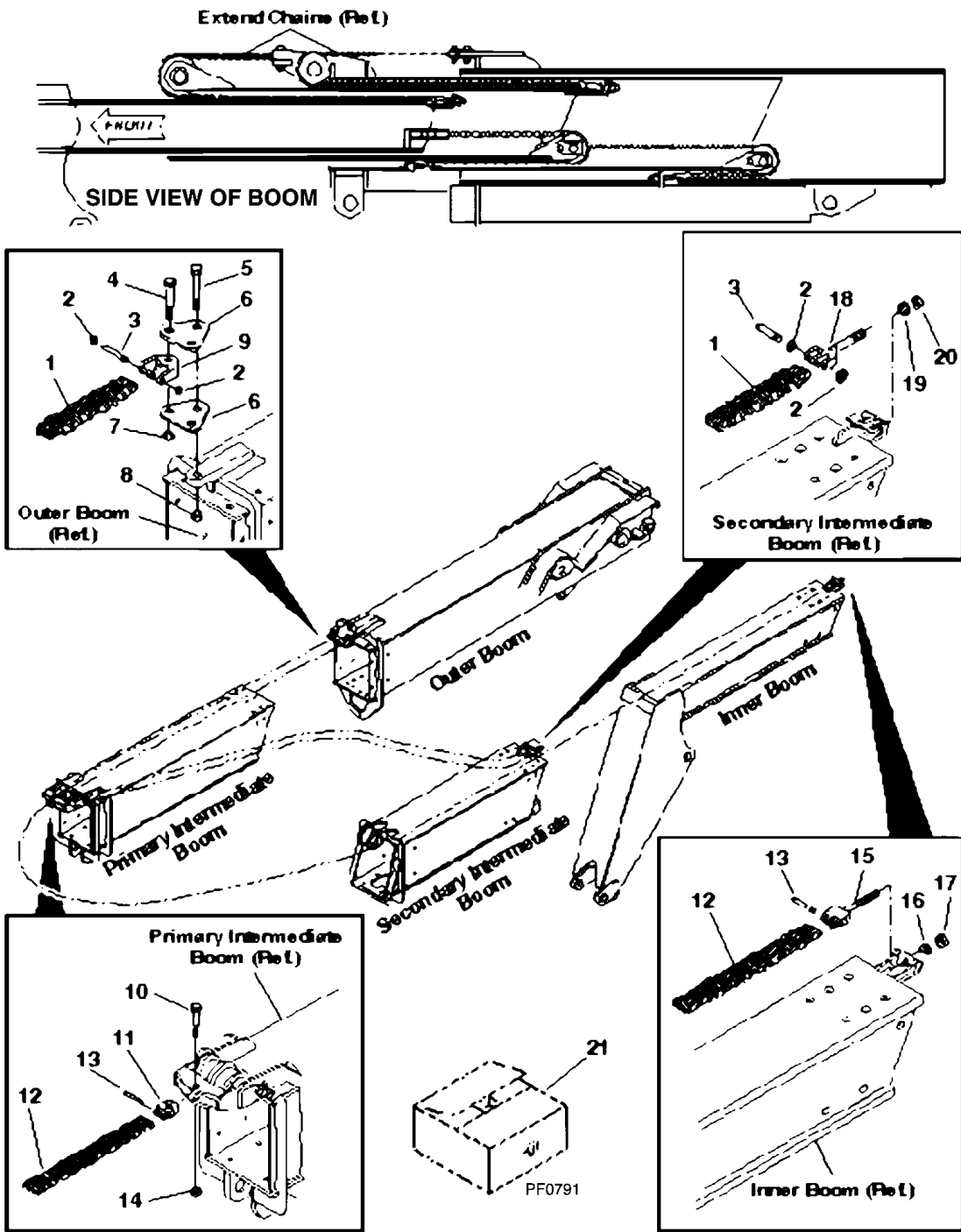

PH0861

SECTION 9 - BOOM AND ATTACHMENTS

FIGURE 9-20. BOOM EXTEND CHAINS - 10054

ITEM	PART NUMBER	QTY	DESCRIPTION	REV
1	NLA	2	Chain, 4 x 6 Link - 194.25in Long (For Service, Order Kit 7138738) (Prior to SN 11145)	
1	8127014	2	Chain, 6 x 6 Link - 194.25in Long (SN 11145 to Present)	
2	8642237	8	Retaining Ring, 1/4in Dia	
3	8124126	4	Pin, Chain Clevis	
4	8310019	2	Bolt, Shoulder 3/8-16 x 1-1/2in	
5	8310020	1	Bolt, Shoulder 1/2-13 x 1-1/2in	
6	7089781	2	Yoke, Extend Chain	
7	8305645	2	Nut, Hex Lock Elastic 3/8-16	
8	8305644	1	Nut, Hex Lock Elastic 1/2-13	
9	NLA	2	Clevis, 4 x 6 Chain (For Service, Order Kit P/N 7138738) (Prior to SN 11145)	
9	7119372	2	Clevis, 6 x 6 Chain (SN 11145 to Present)	
10	8310205	1	Bolt, Shoulder 5/8-11 x 2-1/2in	
11	7113982	1	Clevis, 6 x 6 Chain	
12	8127009	1	Chain, 6 x 6 Link - 193in Long	
13	8124131	2	Pin, Chain Clevis (Includes two cotter pins)	
14	8305643	1	Nut, Lock Elastic 5/8-11	
15	7113952	1	Clevis, 6 x 6 Chain	
16	8310066	1	Washer, Flat 1in	
17	8310210	1	Nut, Lock Elastic 1in - 14	
18	NLA	2	Clevis, 4 x 6 Chain (For Service, Order Kit P/N 7138738) (Prior to SN 11145)	
18	7119362	2	Clevis, 6 x 6 Chain (SN 11145 to Present)	
19	8307104	2	Washer, Flat 3/4in	
20	8305646	2	Nut, Lock Elastic 3/4-16	
21	7138738	2	Kit, Extend Chain (Replaces one 4 x 6 Link Chain and Clevis assembly with one 6 x 6 Link Chain and Clevis Assembly. Replace as a pair)	

SECTION 9 - BOOM AND ATTACHMENTS

FIGURE 9-21. BOOM RETRACT CHAINS - 10054 (Prior to SN 0885)

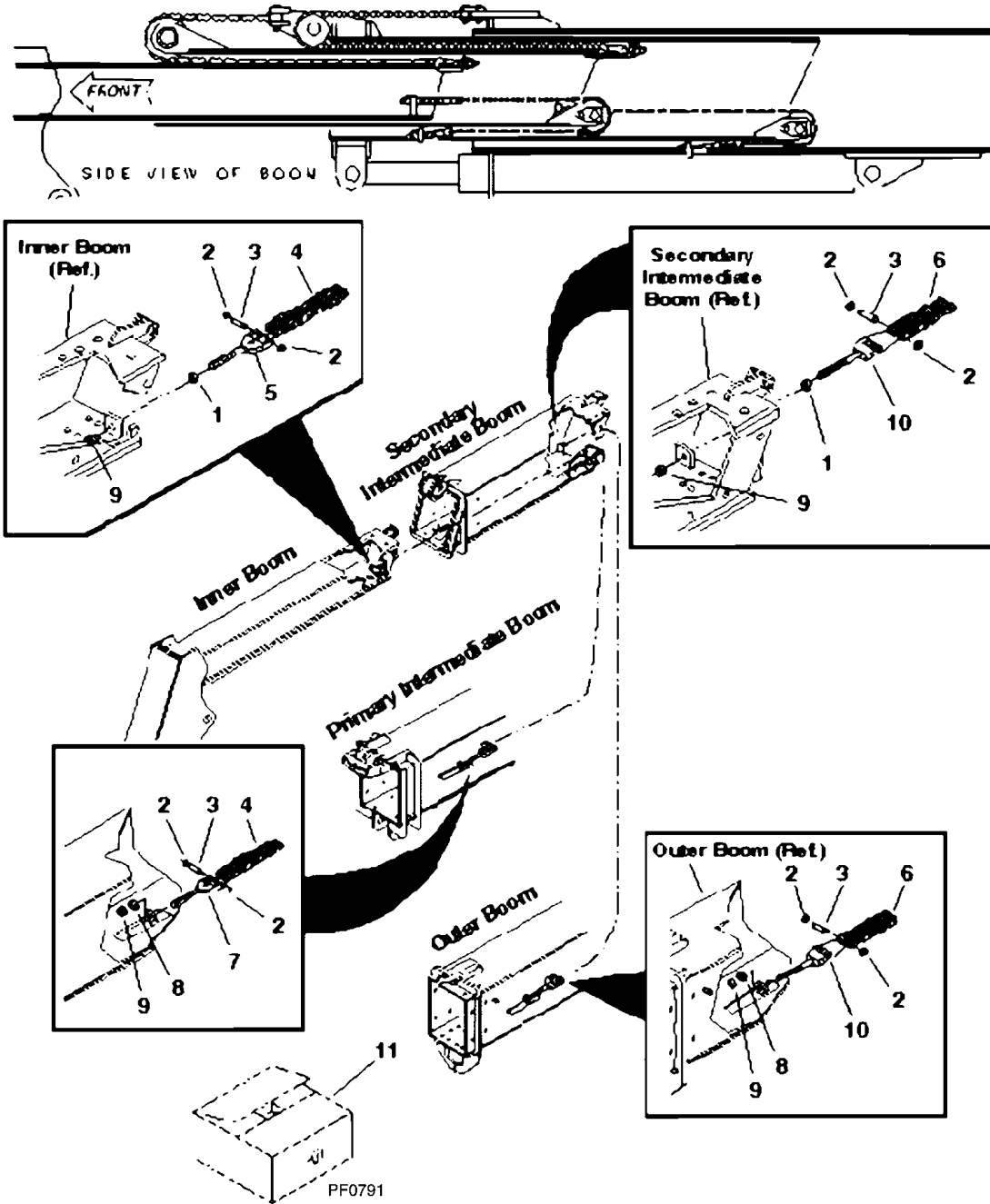

PH0891

SECTION 9 - BOOM AND ATTACHMENTS

FIGURE 9-21. BOOM RETRACT CHAINS - 10054 (Prior to SN 0885)

ITEM	PART NUMBER	QTY	DESCRIPTION	REV
1	8305018	1	Nut, Hex Jam 3/4-16	
2	8642237	8	Retaining Ring, 1/4in	
3	8124126	4	Pin, Chain Clevis	
4	NLA	1	Chain, 4 x 6 - 164.25in Long (For Service, Order Kit P/N 7120191)	
5	NLA	2	Clevis, 4 x 6 Chain (For Service, Order Kit P/N 7120191)	
6	8127008	1	Chain, 6 x 6 - 164.25in Long	
7	NLA	NLA	Clevis, 4 x 6 Chain (For Service, Order Kit P/N 7120191)	
8	8307104	2	Washer, Flat 3/4in	
9	8305646	4	Nut, Hex Lock Elastic 3/4-16	
10	7119362	2	Clevis, 6 x 6 Chain	
		Ref	KITS	
11	7120191	1	Kit, Retract Chain (Replaces 4 x 6 Link Chain with 6 x 6 Link Chain)	

SECTION 9 - BOOM AND ATTACHMENTS

FIGURE 9-22. BOOM RETRACT CHAINS - 10054 (SN 0885 through 1084)

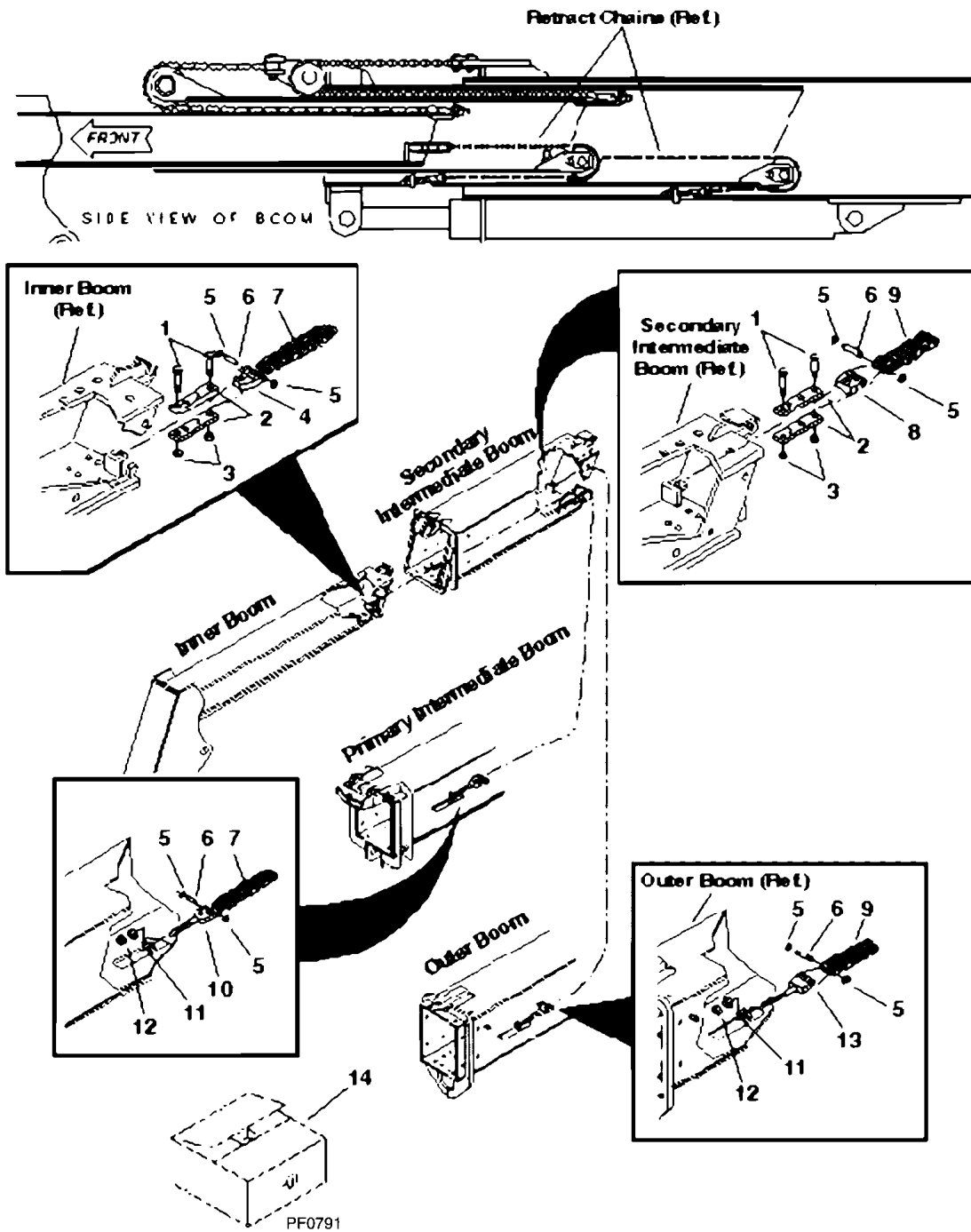

SECTION 9 - BOOM AND ATTACHMENTS

FIGURE 9-22. BOOM RETRACT CHAINS - 10054 (SN 0885 through 1084)

ITEM	PART NUMBER	QTY	DESCRIPTION	REV
1	8310019	4	Bolt, Shoulder 3/8-16 x 1-1/2	
2	7117031	4	Link	
3	8305645	4	Nut, Hex Lock Elastic 3/8-16	
4	NLA	1	Clevis, 4 x 6 Chain (For Service, Order Kit P/N 7119351)	
5	8642237	8	Retaining Ring, 1/4in	
6	8124126	4	Pin, Chain Clevis	
7	NLA	1	Chain, 4 x 6 - 164.25in Long (For Service, Order Kit P/N 7119351)	
8	7119372	1	Clevis, 6 x 6 Chain	
9	8127008	1	Chain, 6 x 6 Link - 164.25in Long	
10	NLA	1	Clevis, 4 x 6 Chain (For Service, Order Kit P/N 7119351)	
11	8307104	2	Washer, Flat 3/4in	
12	8305646	2	Nut, Hex Lock Elastic 3/4-16	
13	7119362	1	Clevis, 6 x 6 Chain	
		Ref	KITS	
14	7119351	1	Kit, Retract Chain (Replaces 4 x 6 Link Chain with 6 x 6 Link Chain)	

SECTION 9 - BOOM AND ATTACHMENTS

FIGURE 9-23. BOOM RETRACT CHAINS - 10054 (SN 1085 through 13197)

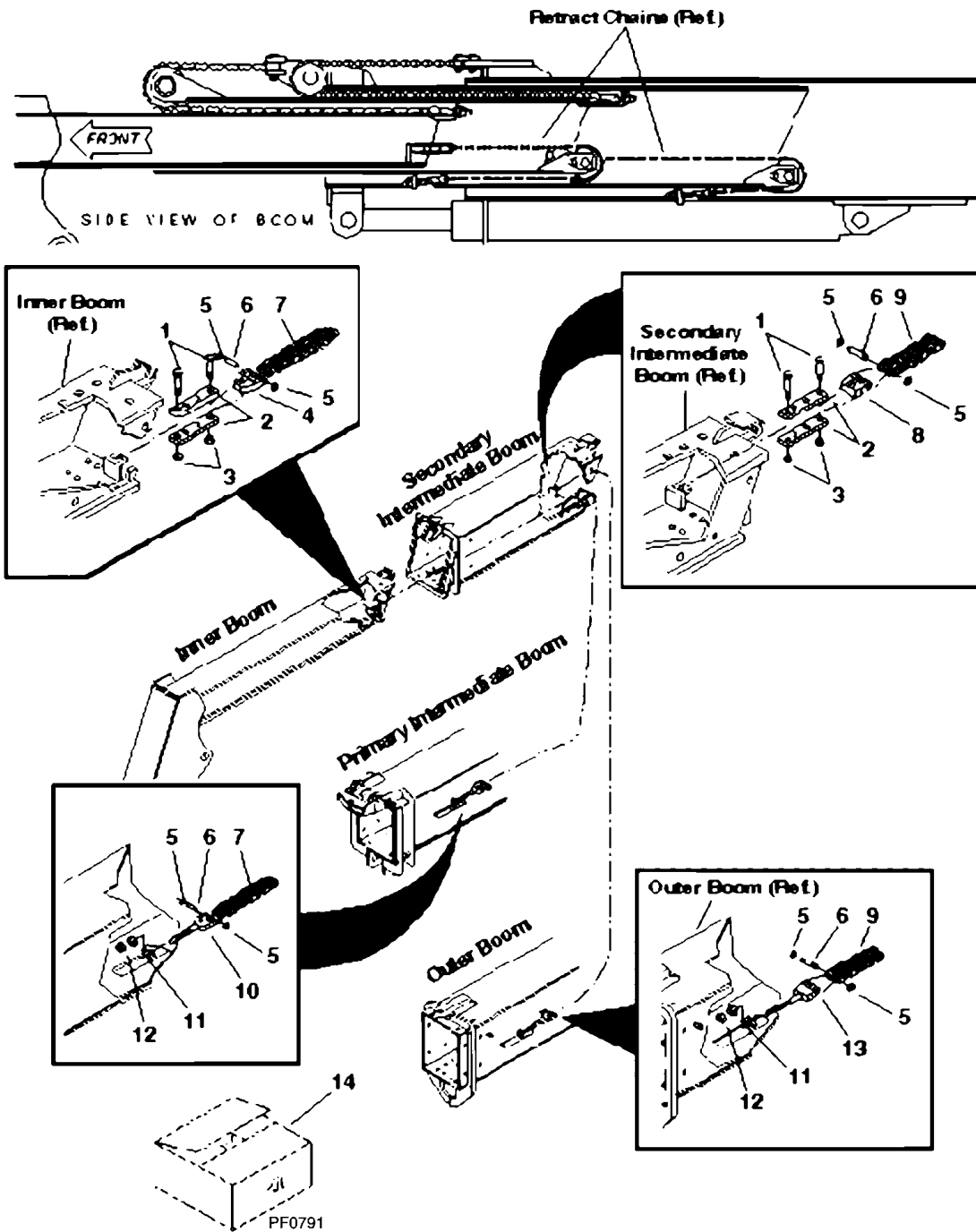

PH0870

SECTION 9 - BOOM AND ATTACHMENTS

FIGURE 9-23. BOOM RETRACT CHAINS - 10054 (SN 1085 through 13197)

ITEM	PART NUMBER	QTY	DESCRIPTION	REV
1	8310019	4	Bolt, Shoulder 3/8-16 x 1-1/2in	
2	7117031	4	Link	
3	8305645	4	Nut, Hex Lock Elastic 3/8-16	
4	NLA	1	Clevis, 4 x 6 Chain (For Service, Order Kit P/N 7119351) (Prior to SN 11569)	
4	7119372	1	Clevis, 6 x 6 Chain (SN 11569 to Present)	
5	8642237	8	Retaining Ring 1/4in	
6	8124126	4	Pin, Chain Clevis	
7	NLA	1	Chain, 4 x 6 Link - 164.25in Long (For Service, Order Kit P/N 7119351) (Prior to SN 11569)	
7	8127008	1	Chain, 6 x 6 Link - 164.25in Long (SN 11569 to Present)	
8	7119372	1	Clevis, 6 x 6 Chain	
9	8127008	1	Chain, 6 x 6 Link - 164.25in Long	
10	NLA	1	Clevis, 4 x 6 Chain (For Service, Order Kit P/N 7119351) (Prior to SN 11569)	
10	7119362	1	Clevis, 6 x 6 Chain (SN 11569 to Present)	
11	8307104	2	Washer, Flat 3/4in	
12	8305646	2	Nut, Hex Lock Elastic 3/4-16	
13	7119362	1	Clevis, 6 x 6 Chain	
		Ref	KITS	
14	7119351	1	Kit, Retract Chain (Replaces 4 x 6 Link Chain with 6 x 6 Link Chain)	

SECTION 9 - BOOM AND ATTACHMENTS

FIGURE 9-24. TRUSS BOOM 12 & 15 FT (OPTIONAL)

12 ft. Truss Boom
8042 Only

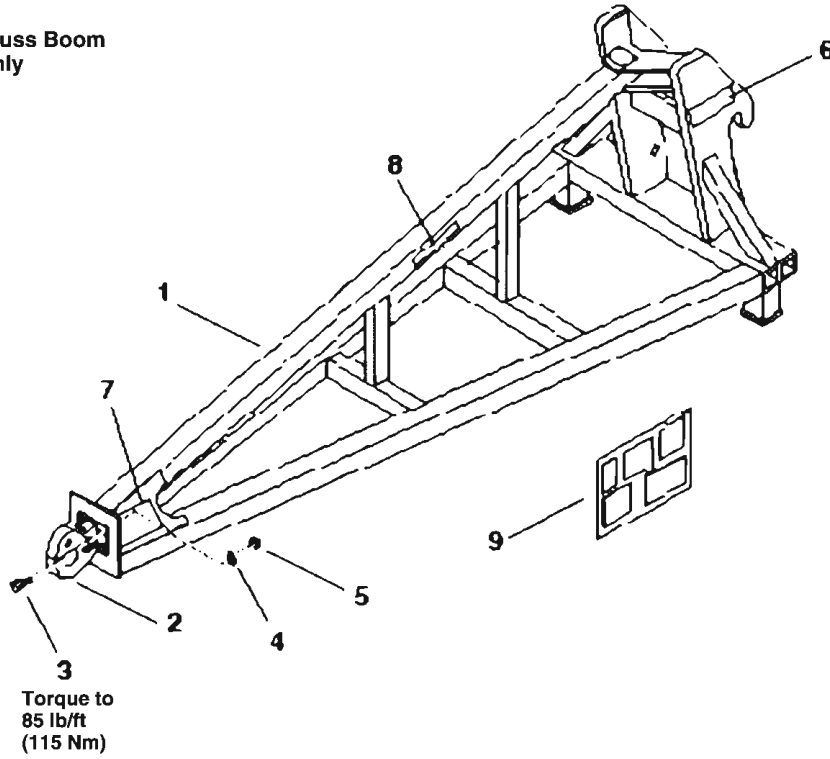

15 ft. Truss Boom
10042 & 10054 Only

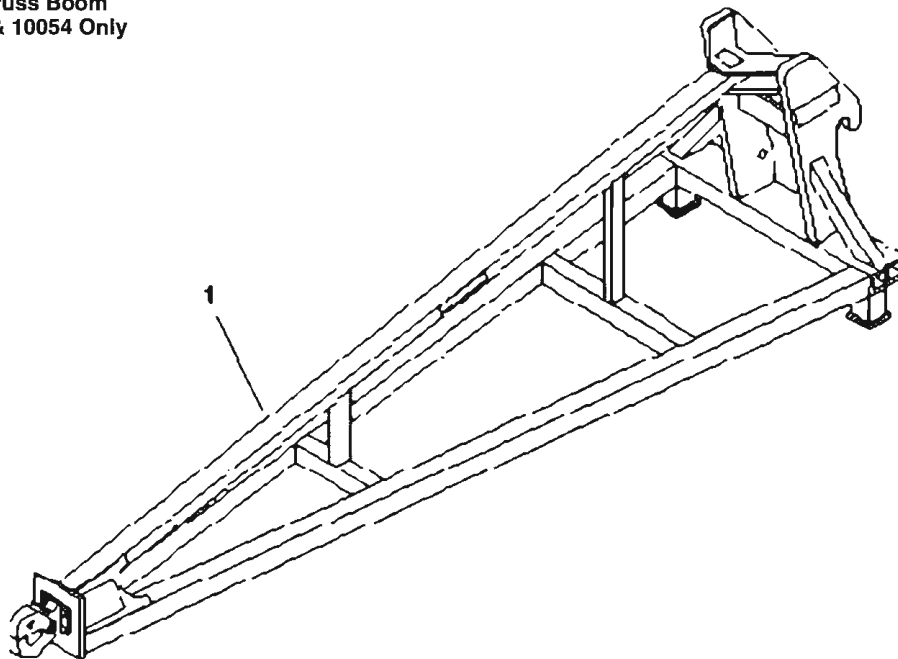

PH0970

SECTION 9 - BOOM AND ATTACHMENTS

FIGURE 9-24. TRUSS BOOM 12 & 15 FT (OPTIONAL)

ITEM	PART NUMBER	QTY	DESCRIPTION	REV
1	7113024	1	12ft Truss Boom - 8042 (Includes Items 2 thru 9)	
1	7112804	1	15ft Truss Boom - 10042 & 10054 (Includes Items 2 thru 9)	
2	8382017	1	Pintle Hook	
3	8310195	4	HHCS, 1/2-13 x 1.75in	
4	8307112	4	Washer, Plain 1/2 SAE	
5	8305644	4	Nut, Hex Lock Elastic 1/2-13	
6	4107182	2	Decal, Name	
7	4107822	2	Decal, Swinging Load	
8	4107832	2	Decal, Length/Capacity	
9	4107812	2	Chart, Capacity	

SECTION 10 GENERAL TROUBLESHOOTING

HYDRAULIC

Hydraulic Diagnostic Test Equipment	289
8042 Hydraulic Diagram & Testing (S/N 1167 & Before)	290 - 291
8042 Hydraulic Diagram & Testing (S/N 1168 thru 2194)	292 - 293
8042 Hydraulic Diagram & Testing (S/N 2195 thru 9908)	294 - 295
8042 Hydraulic Diagram & Testing (S/N 9909 & After)	296 - 297
10042 Hydraulic Diagram & Testing (S/N 1167 & Before)	298 - 299
10042 Hydraulic Diagram & Testing (S/N 1168 thru 2194)	300 - 301
10042 Hydraulic Diagram & Testing (S/N 2195 thru 9908)	302 - 303
10042 Hydraulic Diagram & Testing (S/N 9909 & After)	304 - 305
10054 Hydraulic Diagram & Testing (S/N 1167 & Before)	306 - 307
10054 Hydraulic Diagram & Testing (S/N 1168 thru 2194)	308 - 309
10054 Hydraulic Diagram & Testing (S/N 2195 thru 9908)	310 - 311
10054 Hydraulic Diagram & Testing (S/N 9909 & After)	312 - 313
8042/10042/10054 Variable Volume Load Sensing Pump Flow Meter Diagram (S/N 9908 & Before) ...	314
8042/10042/10054 Variable Volume Load Sensing Pump Flow Meter Diagram (S/N 9909 & After) ...	315
8042/10042 Hoist and Extend Circuits (S/N 8540 & Before)	316
8042/10042 Hoist and Extend Schematic (S/N 8540 & Before)	317
8042/10042 Hoist and Extend Circuits (S/N 8541 thru 9908)	318
8042/10042 Hoist and Extend Schematic (S/N 8541 thru 9908)	319
8042/10042 Hoist and Extend Circuits (S/N 9909 & After)	320
8042/10042 Hoist and Extend Schematic (S/N 9909 & After)	321
10054 Hoist and Extend Circuits (S/N 8540 & Before)	322
10054 Hoist and Extend Schematic (S/N 8540 & Before)	323
10054 Hoist and Extend Circuits (S/N 8541 thru 9908)	324
10054 Hoist and Extend Schematic (S/N 8541 thru 9908)	325
10054 Hoist and Extend Circuits (S/N 9909 & After)	326
10054 Hoist and Extend Schematic (S/N 9909 & After)	327
8042/10042/10054 Frame Tilt, Attachment Tilt, Slave & Auxiliary Circuits (S/N 2194 & Before)	328
8042/10042/10054 Frame Tilt, Attachment Tilt, Slave & Auxiliary Schematic (S/N 2194 & Before) ...	329
8042/10042/10054 Frame Tilt, Attachment Tilt, Slave & Auxiliary Circuits (S/N 2195 thru 9908)	330
8042/10042/10054 Frame Tilt, Attachment Tilt, Slave & Auxiliary Schematic (S/N 2195 thru 9908) ...	331
8042/10042/10054 Frame Tilt, Attachment Tilt, Slave & Auxiliary Circuits (S/N 9909 & After)	332
8042/10042/10054 Frame Tilt, Attachment Tilt, Slave & Auxiliary Schematic (S/N 9909 & After)	333
8042/10042/10054 Steering Circuit (S/N 9908 & Before)	334
8042/10042/10054 Steering Schematic (S/N 9908 & Before)	335
8042/10042/10054 Steering Circuit (S/N 9909 & After)	336
8042/10042/10054 Steering Schematic (S/N 9909 & After)	337
8042/10042/10054 Service Brake & De-Clutch Circuits (S/N 9908 & Before)	338
8042/10042/10054 Service Brake & De-Clutch Schematic (S/N 9908 & Before)	339
8042/10042/10054 Service Brake Circuit (S/N 9909 & After)	340
8042/10042/10054 Service Brake Schematic (S/N 9909 & After)	341
10042/10054 Outrigger Schematic (S/N 10881 & Before)	342
10042/10054 Outrigger Schematic (S/N 10882 & After)	343

ELECTRICAL

8042/10042 Electrical Schematic (S/N 0291 & Before)	344
8042/10042 Electrical Schematic (S/N 0292 thru 9908)	345
8042/10042 Electrical Schematic (S/N 9909 & After)	346
10054 Electrical Schematic (S/N 9908 & Before)	347
10054 Electrical Schematic (S/N 9909 & After)	348
10042 Outrigger Logic Circuit	349
10054 Outrigger Logic Circuit (S/N 9908 & Before)	350
10054 Outrigger Logic Circuit (S/N 9909 & After)	351

8042/10042/10054 Lighting System Circuit (Optional)	352
8042/10042/10054 Charging Circuit	353
8042/10042/10054 Cranking Circuit (S/N 9908 & Before)	354
8042/10042/10054 Cranking Circuit (S/N 9909 & After)	355
8042/10042 Steer Select Circuit (S/N 0291 & Before)	356
8042/10042/10054 Steer Select Circuit (S/N 0292 & After)	357
8042/10042 Stabilizer Circuit (S/N 0291 & Before)	358
8042/10042 Stabilizer Circuit (S/N 0292 thru S/N 9908)	359
8042/10042 Stabilizer Circuit (S/N 9909 & After)	360
10054 Stabilizer Circuit (S/N 9908 & Before)	361
10054 Stabilizer Circuit (S/N 9909 & After)	362

STABIL-TRAK SYSTEM

Stabil-TRAK System	364 - 367
8042/10042 Stabil-TRAK System Troubleshooting (S/N 9908 & Before)	368
8042/10042 Stabil-TRAK Electrical Circuit Ignition "OFF"(S/N 9908 & Before)	369
8042/10042 Stabil-TRAK Electrical Circuit Free Pivot Mode (S/N 9908 & Before)	370
8042/10042 Stabil-TRAK Hydraulic Circuit Free Pivot Mode (S/N 9908 & Before)	371
8042/10042 Stabil-TRAK Electrical Circuit Final Positioning Mode (S/N 9908 & Before)	372
8042/10042 Stabil-TRAK Hydraulic Circuit Final Positioning Mode (S/N 9908 & Before)	373
8042/10042 Stabil-TRAK Electrical Circuit Locked Mode (S/N 9908 & Before)	374
8042/10042 Stabil-TRAK Hydraulic Circuit Locked Mode (S/N 9908 & Before)	375
8042/10042 Stabil-TRAK System Troubleshooting (S/N 9909 & After)	376
8042/10042 Stabil-TRAK Electrical Circuit Ignition "OFF" (S/N 9909 & After)	377
8042/10042 Stabil-TRAK Electrical Circuit Free Pivot Mode (S/N 9909 & After)	378
8042/10042 Stabil-TRAK Hydraulic Circuit Free Pivot Mode (S/N 9909 & After)	379
8042/10042 Stabil-TRAK Electrical Circuit Final Positioning Mode (S/N 9909 & After)	380
8042/10042 Stabil-TRAK Hydraulic Circuit Final Positioning Mode (S/N 9909 & After)	381
8042/10042 Stabil-TRAK Electrical Circuit Locked Mode (S/N 9909 & After)	382
8042/10042 Stabil-TRAK Hydraulic Circuit Locked Mode (S/N 9909 & After)	383
10054 Stabil-TRAK System Troubleshooting (S/N 9908 & Before)	384 - 385
10054 Stabil-TRAK Electrical Circuit Boom Extend Mode 1 (S/N 9908 & Before)	386
10054 Stabil-TRAK Electrical Circuit Boom Extend Mode 2 (S/N 9908 & Before)	387
10054 Stabil-TRAK Electrical Circuit Boom Extend Mode 3 (S/N 9908 & Before)	388
10054 Stabil-TRAK Electrical Circuit Boom Extend Mode 4 (S/N 9908 & Before)	389
10054 Stabil-TRAK Electrical Circuit Boom Extend Mode 5 (S/N 9908 & Before)	390
10054 Stabil-TRAK Electrical Circuit Boom Extend Mode 6 (S/N 9908 & Before)	391
10054 Stabil-TRAK Electrical Circuit Boom Extend Mode 7 (S/N 9908 & Before)	392
10054 Stabil-TRAK Electrical Circuit Boom Extend Mode 8 (S/N 9908 & Before)	393
10054 Stabil-TRAK Electrical Circuit Boom Extend Mode 9 (S/N 9908 & Before)	394
10054 Stabil-TRAK System Troubleshooting (S/N 9909 & After)	396 - 397
10054 Stabil-TRAK Electrical Circuit Boom Extend Mode 1 (S/N 9909 & After)	398
10054 Stabil-TRAK Electrical Circuit Boom Extend Mode 2 (S/N 9909 & After)	399
10054 Stabil-TRAK Electrical Circuit Boom Extend Mode 3 (S/N 9909 & After)	400
10054 Stabil-TRAK Electrical Circuit Boom Extend Mode 4 (S/N 9909 & After)	401
10054 Stabil-TRAK Electrical Circuit Boom Extend Mode 5 (S/N 9909 & After)	402
10054 Stabil-TRAK Electrical Circuit Boom Extend Mode 6 (S/N 9909 & After)	403
10054 Stabil-TRAK Electrical Circuit Boom Extend Mode 7 (S/N 9909 & After)	404
10054 Stabil-TRAK Electrical Circuit Boom Extend Mode 8 (S/N 9909 & After)	405
10054 Stabil-TRAK Electrical Circuit Boom Extend Mode 9 (S/N 9909 & After)	406

Hydraulic Diagnostic Test Equipment

OmniQuip Parts Worldwide is pleased to announce the availability of two valuable diagnostic tools. The **Sky Trak** Pressure Test Kit and Flowmeter Kit. Both kits feature a durable polyethylene carrying case for demanding field service conditions. For price and availability, call OmniQuip Parts Worldwide at (888) 872-5123.

Pressure Test Kit

- Contains all the fittings and hoses required to test **Sky Trak** Telescopic Material Handlers
- 300, 1000 and 4000 psi gauges for accurate testing of high and low pressure circuits
- Includes laminated Test Diagrams and Testing Procedures for troubleshooting **Sky Trak** Telescopic Material Handlers
- 13" x 18" x 7" durable carrying case

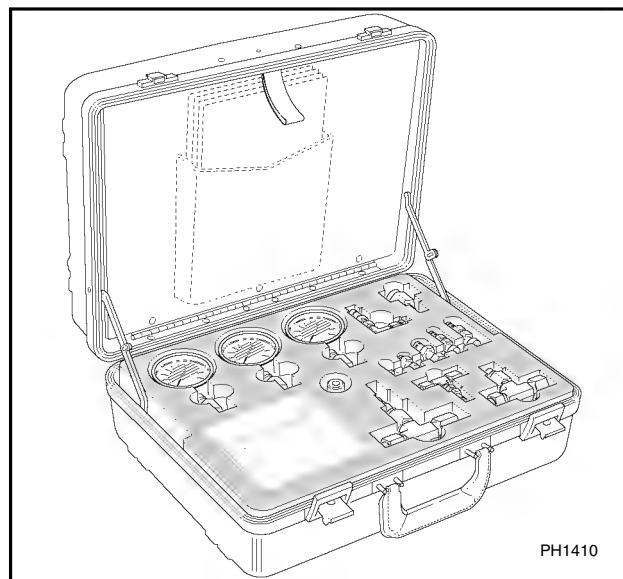

PH1410

Flowmeter Kit

- Use Flowmeter Kit to pinpoint hydraulic system faults.
- Includes flowmeter with load valve, magnetic base, photo tachometer head and flex arm
- Measures up to 60 GPM and 6000 psi
- Bi-directional for unrestricted connection and simplified testing
- Internal by-pass protects system and tester from over-pressure
- 16" x 22" x 7" durable carrying case

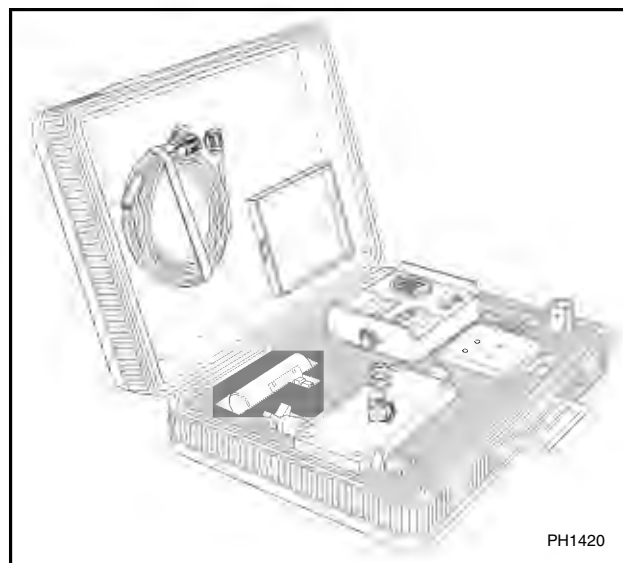

PH1420

Ordering & Price Information

Part Number	Description	Approximate Weight	Price and Availability
7133413	Hydraulic Pressure Test Kit	16 lbs.	Consult Factory
1321107	Hydraulic Flowmeter Kit	28 lbs.	Consult Factory

8042 Hydraulic Diagram (S/N 1167 & Before)

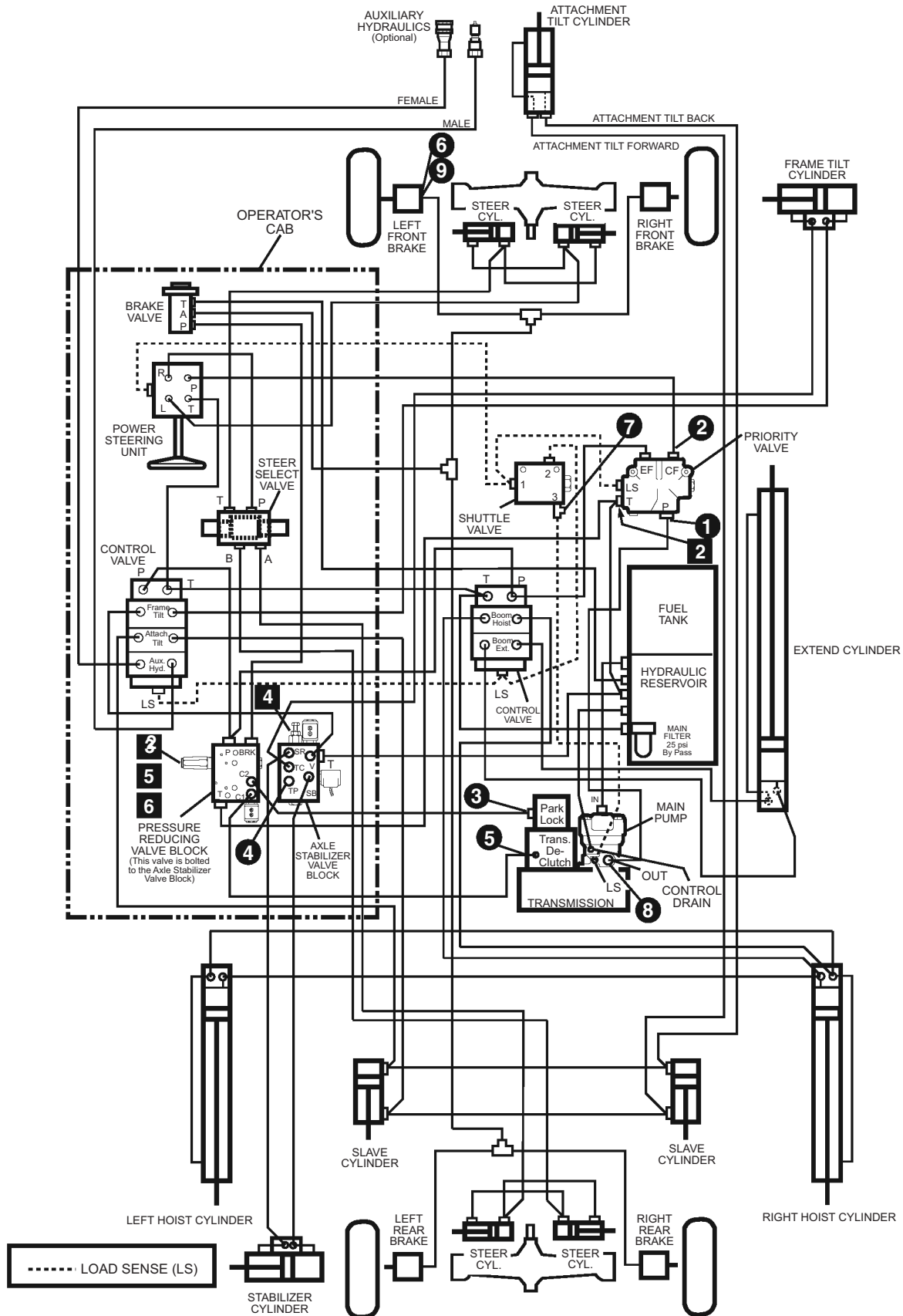

8042 Hydraulic Testing (S/N 1167 & Before)

Engine Information

Idle 1,050 ± 50 rpm
Full Speed 2,730 ± 130 rpm

Hydraulic Oil Information

Oil Type - 10W, meets MIL-L-2104C or ISO Grade 46
Capacity - Reservoir 30.3 gal. (114,7 liter)
Capacity - System 47.3 gal. (179 liter)

Note 1: To adjust relief settings or pressure reducing settings, turn the adjustment screw clockwise to increase pressure or counterclockwise to decrease pressure.

***Note 2:** On units with S/N 0654 & Before. If the low brake pressure kit has been installed, as offered in Service Bulletin STB-2076, issued 5-29-95, refer to test location 9.

The hydraulic oil temperature for the pump flow test should be between 100° F (38° C) and 120° F (49° C) (tank hot to the touch) during testing.

Equipment Needed To Perform Tests From Kit P/N 7118782

Circuit	Gauge	Fittings
1	4,000 PSI Gauge (275,6 bar)	#12 Run Tee Swivel Nut End Reducer #12-8 PD38TX Test Nipple
2	4,000 PSI Gauge (275,6 bar)	#8 Run Tee Swivel Nut PD38TX Test Nipple
3 5	1,000 PSI Gauge (68,9 bar)	#4 Union PD34BTX Test Nipple
4	300 PSI Gauge (20,7 bar)	Connector STR. THD. #4 PD34BTX Test Nipple
6 9	1,000 PSI Gauge (68,9 bar)	#4 Run Tee Swivel Nut PD34BTX Test Nipple
7	4,000 PSI Gauge (275,6 bar)	#6 Elbow 90° Swivel Nut PD36BTX Test Nipple

TEST LOCATION	Hydraulic Pump Flow Test
8	To check flow readings a flow meter capable of measuring 60 GPM (3,8 ltr/sec) and a load valve capable of 6,000 psi (413,4 bar) will be required (not included with kit P/N 7118782). 2,000 psi (137,8 bar) load @ Engine Speed of 2,500 ± 25 rpm — Flow rate should be 39 to 43 GPM (2,5 to 2,7 ltr/sec)

TEST LOCATION	ADJUST. LOCATION	COMPONENT DESCRIPTION	PRESSURE READINGS	PRESSURE TEST PROCEDURES
1	N/A	Pump Standby Pressure	550 ± 50 psi (37,9 ± 3,4 bar)	Loosen load sense line at location 7 to bleed off pressure and then retighten line. With engine at idle and all hydraulic functions in neutral position, check pump standby pressure.
	N/A	Pump Pressure Compensator	2,950 ± 50 psi (203,3 ± 3,4 bar)	With engine at idle fully retract boom extend cylinder and hold. Check pump maximum pressure.
2	2	Priority Valve Steering Relief	2,500 ± 50 psi (172,3 ± 3,4 bar)	With engine at idle turn the steering wheel all the way to the left or right and hold while checking pressure. If pressure is not correct, adjust or replace the relief valve cartridge in the priority valve (See Note 1).
N/A	N/A	Attachment Tilt Port Relief	3,150 ± 50 psi (217 ± 3,4 bar)	CONSULT FACTORY
3	3	Pressure Reducing Valve In Pressure Reducing Valve Block And Park Brake Release	425 ± 25 psi (29,3 ± 1,7 bar)	With engine at idle and park brake released check pressure. If pressure is not correct, adjust or replace the cartridge in the pressure reducing valve (See Note 1).
4	4	Pressure Reducing Valve In Axle Stabilizer Valve Block	60 ± 10 psi (4,1 ± 0,7 bar)	With engine at idle and boom in the down position check pressure. If pressure is not correct, adjust or replace the cartridge in the axle stabilizer valve (See Note 1).
	N/A	Relief Check Valve In Axle Stabilizer Valve Block	100 psi Minimum (6,9 bar)	With engine at idle and boom down, while frame tilting to the left check pressure.
5	5	Transmission De-Clutch	425 ± 25 psi (29,3 ± 1,7 bar)	With engine at idle and park brake engaged check pressure. If pressure is not correct, adjust or replace the cartridge in the pressure reducing valve (See Note 1).
6	6	Service Brakes (*See Note 2) (S/N 0654 & Before)	425 ± 25 psi (29,3 ± 1,7 bar)	With engine at idle depress the service brakes and check pressure. If pressure is not correct, adjust or replace the cartridge in the pressure reducing valve (See Note 1).
7	N/A	Load Sense	Variable 0 to 2,950 psi (0 to 203,3 bar)	With engine at idle operate a specific function (Boom, Frame Tilt, Attachment Tilt, Auxiliary or Steering) and check pressure.
9	N/A	Service Brakes (S/N 0655 thru 1167)	350 ± 25 psi (24,1 ± 1,7 bar)	With engine at idle depress the service brakes and check pressure. If pressure is not correct, recheck pressure reducing valve pressure.

8042 Hydraulic Diagram (S/N 1188 thru 2194)

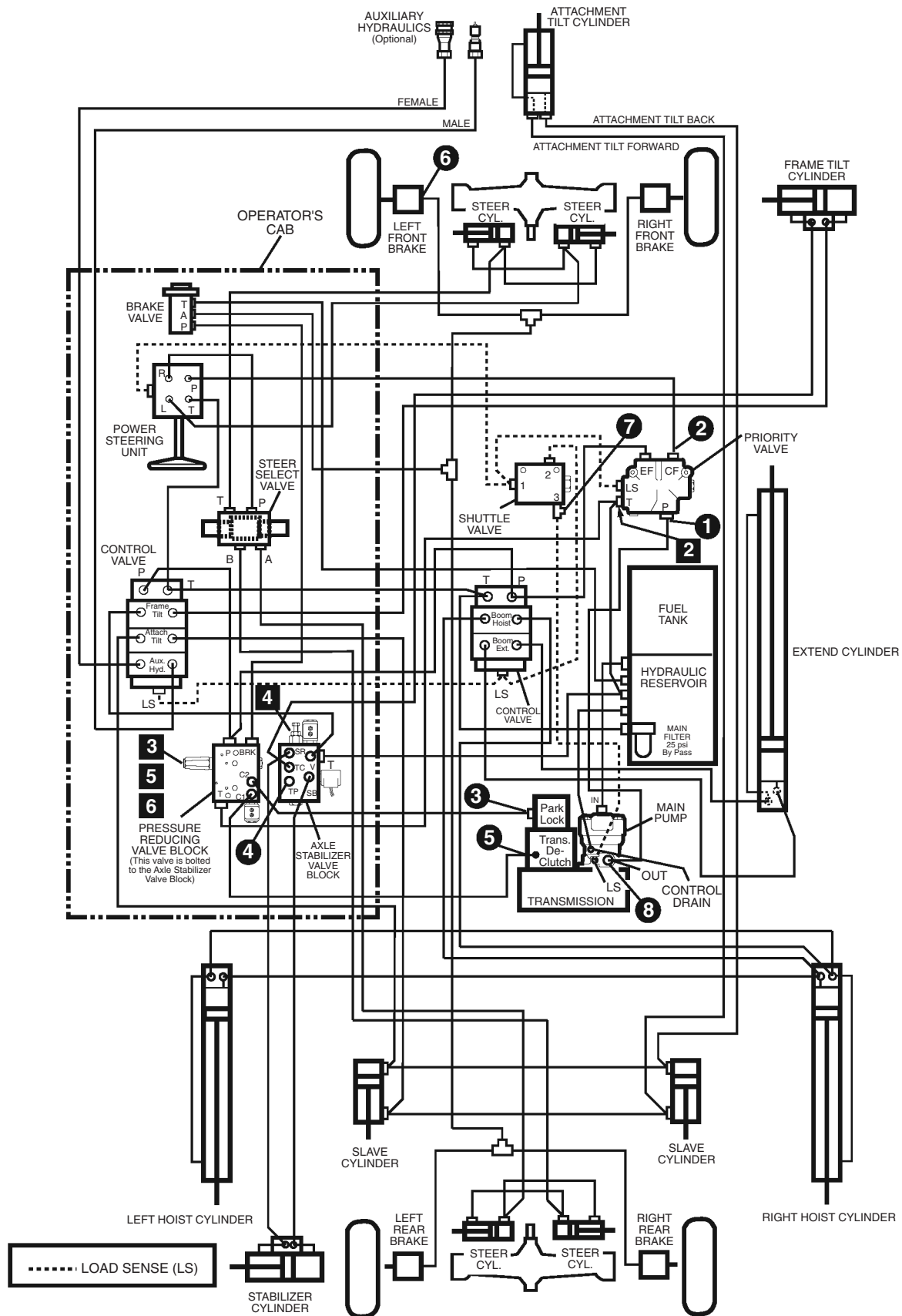

8990272-001
(PH0980)

8042 Hydraulic Testing (S/N 1168 thru 2194)

Engine Information

Idle 1,050 ± 50 rpm
Full Speed 2,730 ± 130 rpm

Hydraulic Oil Information

Oil Type - 10W, meets MIL-L-2104C or ISO Grade 46
Capacity - Reservoir 30.3 gal. (114,7 liter)
Capacity - System 47.3 gal. (179 liter)

Note: To adjust relief settings or pressure reducing settings, turn the adjustment screw clockwise to increase pressure or counterclockwise to decrease pressure.

The hydraulic oil temperature for the pump flow test should be between 100° F (38° C) and 120° F (49° C) (tank hot to the touch) during testing.

Equipment Needed To Perform Tests From Kit P/N 7118782

Circuit	Gauge	Fittings
1	4,000 PSI Gauge (275,6 bar)	#12 Run Tee Swivel Nut End Reducer #12-8 PD38TX Test Nipple
2	4,000 PSI Gauge (275,6 bar)	#8 Run Tee Swivel Nut PD38TX Test Nipple
3 5	1,000 PSI Gauge (68,9 bar)	#4 Union PD34BTX Test Nipple
4	300 PSI Gauge (20,7 bar)	Connector STR. THD. #4 PD34BTX Test Nipple
6	1,000 PSI Gauge (68,9 bar)	#4 Run Tee Swivel Nut PD34BTX Test Nipple
7	4,000 PSI Gauge (275,6 bar)	#6 Elbow 90° Swivel Nut PD36BTX Test Nipple

TEST LOCATION	Hydraulic Pump Flow Test
8	To check flow readings a flow meter capable of measuring 60 GPM (3,8 ltr/sec) and a load valve capable of 6,000 psi (413,4 bar) will be required (not included with kit P/N 7118782). 2,000 psi (137,8 bar) load @ Engine Speed of 2,500 ± 25 rpm — Flow rate should be 39 to 43 GPM (2,5 to 2,7 ltr/sec)

TEST LOCATION	ADJUST. LOCATION	COMPONENT DESCRIPTION	PRESSURE READINGS	PRESSURE TEST PROCEDURES
1	N/A	Pump Standby Pressure	550 ± 50 psi (37,9 ± 3,4 bar)	Loosen load sense line at location 7 to bleed off pressure and then retighten line. With engine at idle and all hydraulic functions in neutral position, check pump standby pressure.
	N/A	Pump Pressure Compensator	2,950 ± 50 psi (203,3 ± 3,4 bar)	With engine at idle fully retract boom extend cylinder and hold. Check pump maximum pressure.
2	2	Priority Valve Steering Relief	2,500 ± 50 psi (172,3 ± 3,4 bar)	With engine at idle turn the steering wheel all the way to the left or right and hold while checking pressure. If pressure is not correct, adjust (inside of "T" port) or replace the relief valve cartridge in the priority valve (See Note).
N/A	N/A	Attachment Tilt Port Relief	3,150 ± 50 psi (217 ± 3,4 bar)	CONSULT FACTORY
3	3	Pressure Reducing Valve In Pressure Reducing Valve Block And Park Brake Release	500 +25/-0 psi (34,5 +1,7/-0 bar)	With engine at idle and park brake released check pressure. If pressure is not correct, adjust or replace the cartridge in the pressure reducing valve (See Note).
4	4	Pressure Reducing Valve In Axle Stabilizer Valve Block	60 ± 10 psi (4,1 ± 0,7 bar)	With engine at idle and boom in the down position check pressure. If pressure is not correct, adjust or replace the cartridge in the axle stabilizer valve (See Note).
	N/A	Relief Check Valve In Axle Stabilizer Valve Block	100 psi Minimum (6,9 bar)	With engine at idle and boom down, while frame tilting to the left check pressure.
5	5	Transmission De-Clutch	500 +25/-0 psi (34,5 +1,7/-0 bar)	With engine at idle and park brake engaged check pressure. If pressure is not correct, adjust or replace the cartridge in the pressure reducing valve (See Note).
6	6	Service Brakes	500 +25/-0 psi (34,5 +1,7/-0 bar)	With engine at idle depress the service brakes and check pressure. If pressure is not correct, adjust or replace the cartridge in the pressure reducing valve (See Note).
7	N/A	Load Sense	Variable 0 to 2,950 psi (0 to 203,3 bar)	With engine at idle operate a specific function (Boom, Frame Tilt, Attachment Tilt, Auxiliary or Steering) and check pressure.

8042 Hydraulic Testing (S/N 2195 thru 9908)

Engine Information

Idle 1,050 ± 50 rpm
Full Speed 2,730 ± 130 rpm

Hydraulic Oil Information

Oil Type - 10W, meets MIL-L-2104C or ISO Grade 46
Capacity - Reservoir 30.3 gal. (114,7 liter)
Capacity - System 47.3 gal. (179 liter)

Note: To adjust relief settings or pressure reducing settings, turn the adjustment screw clockwise to increase pressure or counterclockwise to decrease pressure.

The hydraulic oil temperature for the pump flow test should be between 100° F (38° C) and 120° F (49° C) (tank hot to the touch) during testing.

Equipment Needed To Perform Tests From Kit P/N 7118782

Circuit	Gauge	Fittings
1	4,000 PSI Gauge (275,6 bar)	#12 Run Tee Swivel Nut End Reducer #12-8 PD38TX Test Nipple
2	4,000 PSI Gauge (275,6 bar)	#8 Run Tee Swivel Nut PD38TX Test Nipple
3 5	1,000 PSI Gauge (68,9 bar)	#4 Union PD34BTX Test Nipple
4	1,000 PSI Gauge (68,9 bar)	Connector STR. THD. #4 PD34BTX Test Nipple
6	1,000 PSI Gauge (68,9 bar)	#4 Run Tee Swivel Nut PD34BTX Test Nipple
7	4,000 PSI Gauge (275,6 bar)	#6 Elbow 90° Swivel Nut PD36BTX Test Nipple

TEST LOCATION	Hydraulic Pump Flow Test
8	To check flow readings a flow meter capable of measuring 60 GPM (3,8 ltr/sec) and a load valve capable of 6,000 psi (413,4 bar) will be required (not included with kit P/N 7118782). 2,000 psi (137,8 bar) load @ Engine Speed of 2,500 ± 25 rpm — Flow rate should be 39 to 43 GPM (2,5 to 2,7 ltr/sec)

TEST LOCATION	ADJUST. LOCATION	COMPONENT DESCRIPTION	PRESSURE READINGS	PRESSURE TEST PROCEDURES
1	N/A	Pump Standby Pressure	550 ± 50 psi (37,9 ± 3,4 bar)	Loosen load sense line at location 7 to bleed off pressure and then retighten line. With engine at idle and all hydraulic functions in neutral position, check pump standby pressure.
	N/A	Pump Pressure Compensator	2,950 ± 50 psi (203,3 ± 3,4 bar)	With engine at idle fully retract boom extend cylinder and hold. Check pump maximum pressure.
2	2	Priority Valve Steering Relief	2,500 ± 50 psi (172,3 ± 3,4 bar)	With engine at idle turn the steering wheel all the way to the left or right and hold while checking pressure. If pressure is not correct, adjust (inside of "T" port) or replace the relief valve cartridge in the priority valve (See Note).
N/A	N/A	Attachment Tilt Port Relief	3,150 ± 50 psi (217 ± 3,4 bar)	CONSULT FACTORY
3	3	Pressure Reducing Valve In Pressure Reducing Valve Block And Park Brake Release	500 +25/-0 psi (34,5 +1,7/-0 bar)	With engine at idle and park brake released check pressure. If pressure is not correct, adjust or replace the cartridge in the pressure reducing valve (See Note).
4	4	Pressure Reducing Valve In Axle Stabilizer Valve Block	200 ± 25 psi (13,8 ± 1,7 bar)	With engine at idle and boom in the down position check pressure. If pressure is not correct, adjust or replace the cartridge in the axle stabilizer valve (See Note).
	N/A	Pressure Reducing Valve In Axle Stabilizer Valve Block	275 psi Maximum (18,9 bar)	With engine at idle and boom down, while frame tilting to the left check pressure. If pressure is not correct, recheck adjustment location 4 . If that pressure is correct, replace the cartridge in the axle stabilizer valve.
5	5	Transmission De-Clutch	500 +25/-0 psi (34,5 +1,7/-0 bar)	With engine at idle and park brake engaged check pressure. If pressure is not correct, adjust or replace the cartridge in the pressure reducing valve (See Note).
6	6	Service Brakes	500 +25/-0 psi (34,5 +1,7/-0 bar)	With engine at idle depress the service brakes and check pressure. If pressure is not correct, adjust or replace the cartridge in the pressure reducing valve (See Note).
7	N/A	Load Sense	Variable 0 to 2,950 psi (0 to 203,3 bar)	With engine at idle operate a specific function (Boom, Frame Tilt, Attachment Tilt, Auxiliary or Steering) and check pressure.

8042 Hydraulic Diagram (S/N 9909 & After)

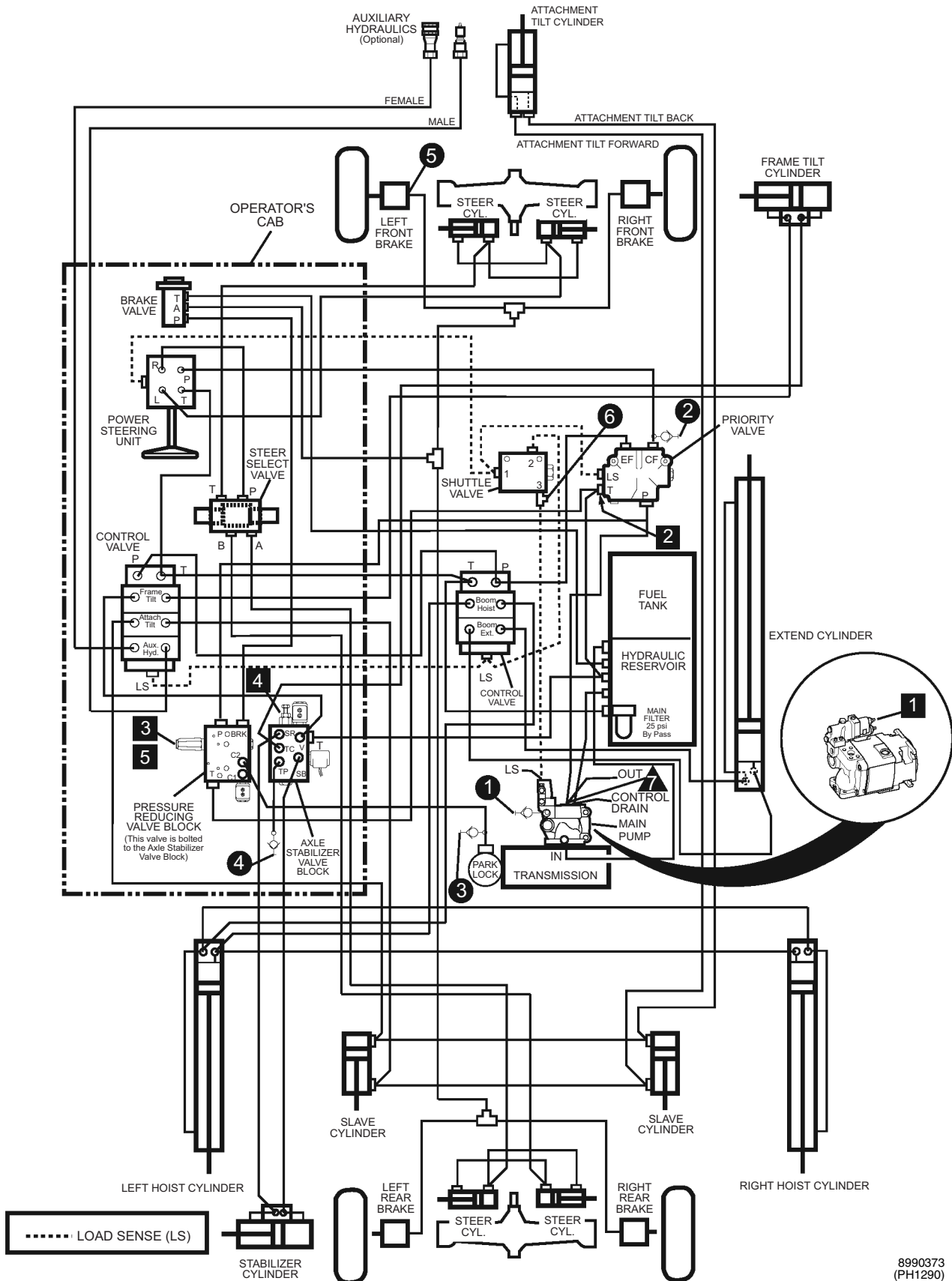

8990373
(PH1290)

8042 Hydraulic Testing (S/N 9909 & After)

Engine Information

Idle 1,050 ± 50 rpm
Full Speed 2,730 ± 130 rpm

Hydraulic Oil Information

Oil Type - 10W, meets MIL-L-2104C or ISO Grade 46
Capacity - Reservoir 30.3 gal. (114,7 liter)
Capacity - System 47.3 gal. (179 liter)

Note: To adjust relief settings, pressure reducing settings or standby pressure, turn the adjustment screw clockwise to increase pressure or counterclockwise to decrease pressure.

The hydraulic oil temperature for the pump flow test should be between 100° F (38° C) and 120° F (49° C) (tank hot to the touch) during testing.

Equipment Needed To Perform Tests From Kit P/N 7133413

Circuit	Gauge	Fittings
1	4,000 PSI Gauge (275,6 bar)	PD38TX Test Nipple
2	4,000 PSI Gauge (275,6 bar)	#8 Run Tee Swivel Nut PD38TX Test Nipple
3	1,000 PSI Gauge (68,9 bar)	#4 Union PD34BTX Test Nipple
4	1,000 PSI Gauge (68,9 bar)	Connector STR. THD. #4 PD34BTX Test Nipple
5	1,000 PSI Gauge (68,9 bar)	#4 Run Tee Swivel Nut PD34BTX Test Nipple
6	4,000 PSI Gauge (275,6 bar)	#6 Elbow 90° Swivel Nut PD36BTX Test Nipple

TEST LOCATION	Hydraulic Pump Flow Test
7	To check flow readings a flow meter capable of measuring 60 GPM (3,8 ltr/sec) and a load valve capable of 6,000 psi (413,4 bar) will be required (not included with kit P/N 7133413). A test nipple is supplied at location 7. 2,000 psi (137,8 bar) load @ Engine Speed of 2,500 ± 25 rpm — Flow rate should be 39 to 43 GPM (2,5 to 2,7 ltr/sec)

TEST LOCATION	ADJUST. LOCATION	COMPONENT DESCRIPTION	PRESSURE READINGS	PRESSURE TEST PROCEDURES
1	1	Pump Standby Pressure	550 ± 50 psi (37,9 ± 3,4 bar)	Loosen load sense line at location 6 to bleed off pressure and then retighten line. With engine at idle and all hydraulic functions in neutral position, check pump standby pressure (See Note).
	N/A	Pump Pressure Compensator	2,950 ± 50 psi (203,3 ± 3,4 bar)	With engine at idle fully retract boom extend cylinder and hold. Check pump maximum pressure.
2	2	Priority Valve Steering Relief	2,500 ± 50 psi (172,3 ± 3,4 bar)	With engine at idle turn the steering wheel all the way to the left or right and hold while checking pressure. If pressure is not correct, adjust (inside of "T" port) or replace the relief valve cartridge in the priority valve.
N/A	N/A	Attachment Tilt Port Relief	3,150 ± 50 psi (217 ± 3,4 bar)	CONSULT FACTORY
3	3	Pressure Reducing Valve In Pressure Reducing Valve Block And Park Brake Release	500 +25/-0 psi (34,5 +1,7/-0 bar)	With engine at idle and park brake released check pressure. If pressure is not correct, adjust or replace the cartridge in the pressure reducing valve (See Note).
4	4	Pressure Reducing Valve In Axle Stabilizer Valve Block	200 ± 25 psi (13,8 ± 1,7 bar)	With engine at idle and boom in the down position check pressure. If pressure is not correct, adjust or replace the cartridge in the axle stabilizer valve (See Note).
	N/A	Pressure Reducing Valve In Axle Stabilizer Valve Block	275 psi Maximum (18,9 bar)	With engine at idle and boom down, while frame tilting to the left check pressure. If pressure is not correct, recheck adjustment location 4. If that pressure is correct, replace the cartridge in the axle stabilizer valve.
5	5	Service Brakes	500 +25/-0 psi (34,5 +1,7/-0 bar)	With engine at idle depress the service brakes and check pressure. If pressure is not correct, adjust or replace the cartridge in the pressure reducing valve (See Note).
6	N/A	Load Sense	Variable 0 to 2,950 psi (0 to 203,3 bar)	With engine at idle operate a specific function (Boom, Frame Tilt, Attachment Tilt, Auxiliary or Steering) and check pressure.

10042 Hydraulic Diagram (S/N 1167 & Before)

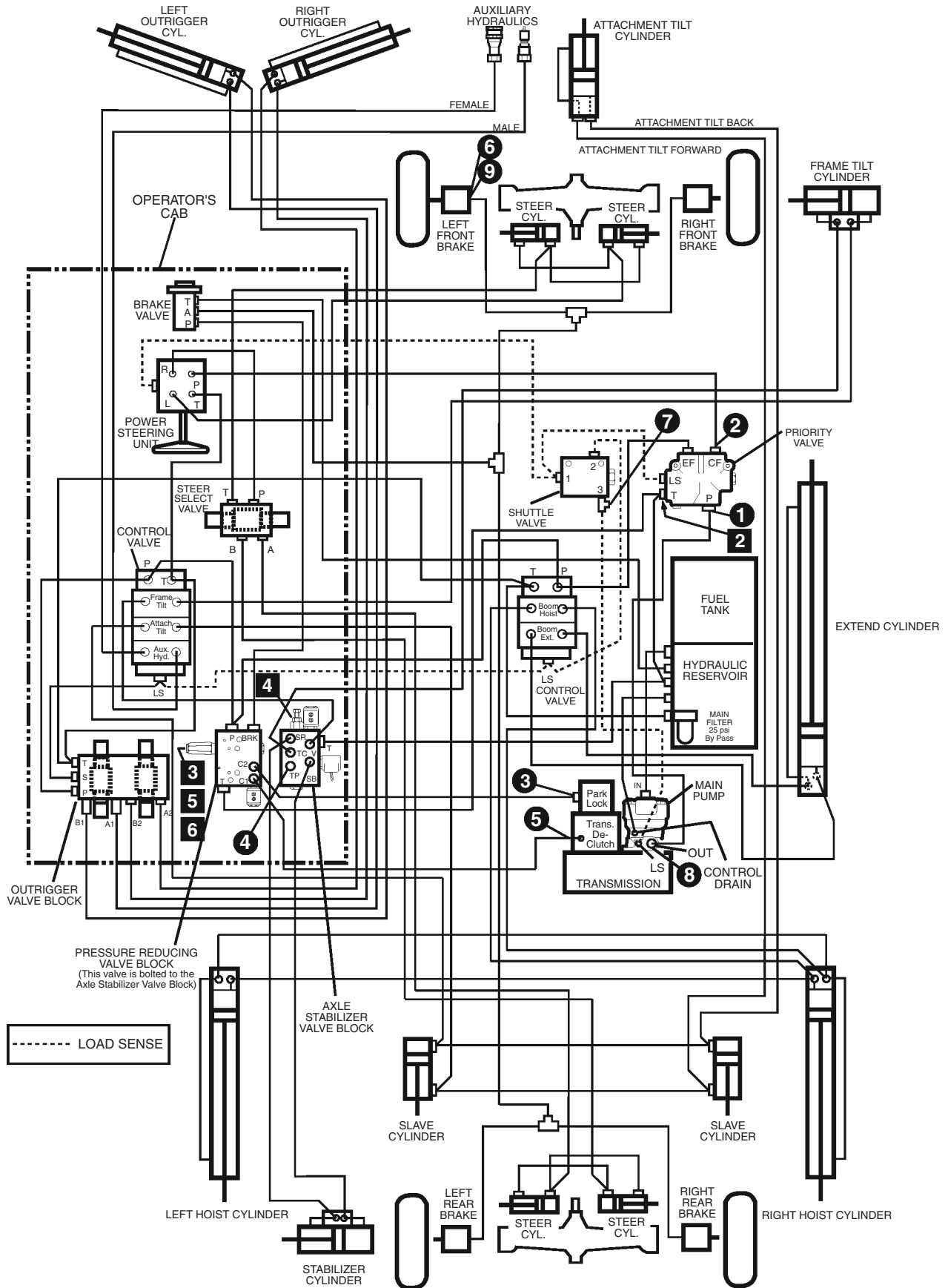

10042 Hydraulic Testing (S/N 1167 & Before)

Engine Information

Idle 1,050 ± 50 rpm
Full Speed 2,730 ± 130 rpm

Hydraulic Oil Information

Oil Type - 10W, meets MIL-L-2104C or ISO Grade 46
Capacity - Reservoir 30.3 gal. (114,7 liter)
Capacity - System 47.3 gal. (179 liter)

Note 1: To adjust relief settings or pressure reducing settings, turn the adjustment screw clockwise to increase pressure or counterclockwise to decrease pressure.

***Note 2:** On units with S/N 0654 & Before. If the low brake pressure kit has been installed, as offered in Service Bulletin STB-2076, issued 5-29-95, refer to test location 9 .

The hydraulic oil temperature for the pump flow test should be between 100° F (38° C) and 120° F (49° C) (tank hot to the touch) during testing.

Equipment Needed To Perform Tests From Kit P/N 7118782

Circuit	Gauge	Fittings
1	4,000 PSI Gauge (275,6 bar)	#12 Run Tee Swivel Nut End Reducer #12-8 PD38TX Test Nipple
2	4,000 PSI Gauge (275,6 bar)	#8 Run Tee Swivel Nut PD38TX Test Nipple
3 5	1,000 PSI Gauge (68,9 bar)	#4 Union PD34BTX Test Nipple
4	300 PSI Gauge (20,7 bar)	Connector STR. THD. #4 PD34BTX Test Nipple
6 9	1,000 PSI Gauge (68,9 bar)	#4 Run Tee Swivel Nut PD34BTX Test Nipple
7	4,000 PSI Gauge (275,6 bar)	#6 Elbow 90° Swivel Nut PD36BTX Test Nipple

TEST LOCATION	Hydraulic Pump Flow Test
8	To check flow readings a flow meter capable of measuring 60 GPM (3,8 ltr/sec) and a load valve capable of 6,000 psi (413,4 bar) will be required (not included with kit P/N 7118782). 2,000 psi (137,8 bar) load @ Engine Speed of 2,500 ± 25 rpm — Flow rate should be 39 to 43 GPM (2,5 to 2,7 ltr/sec)

TEST LOCATION	ADJUST. LOCATION	COMPONENT DESCRIPTION	PRESSURE READINGS	PRESSURE TEST PROCEDURES
1	N/A	Pump Standby Pressure	550 ± 50 psi (37,9 ± 3,4 bar)	Loosen load sense line at location 7 to bleed off pressure and then retighten line. With engine at idle and all hydraulic functions in neutral position, check pump standby pressure.
	N/A	Pump Pressure Compensator	2,950 ± 50 psi (203,3 ± 3,4 bar)	With engine at idle fully retract boom extend cylinder and hold. Check pump maximum pressure.
2	2	Priority Valve Steering Relief	2,500 ± 50 psi (172,3 ± 3,4 bar)	With engine at idle turn the steering wheel all the way to the left or right and hold while checking pressure. If pressure is not correct, adjust or replace the relief valve cartridge in the priority valve (See Note 1).
N/A	N/A	Attachment Tilt Port Relief	3,150 ± 50 psi (217 ± 3,4 bar)	CONSULT FACTORY
3	3	Pressure Reducing Valve In Pressure Reducing Valve Block And Park Brake Release	425 ± 25 psi (29,3 ± 1,7 bar)	With engine at idle and park brake released check pressure. If pressure is not correct, adjust or replace the cartridge in the pressure reducing valve (See Note 1).
4	4	Pressure Reducing Valve In Axle Stabilizer Valve Block	60 ± 10 psi (4,1 ± 0,7 bar)	With engine at idle and boom in the down position check pressure. If pressure is not correct, adjust or replace the cartridge in the axle stabilizer valve (See Note 1).
	N/A	Relief Check Valve In Axle Stabilizer Valve Block	100 psi Minimum (6,9 bar)	With engine at idle and boom down, while frame tilting to the left check pressure.
5	5	Transmission De-Clutch	425 ± 25 psi (29,3 ± 1,7 bar)	With engine at idle and park brake engaged check pressure. If pressure is not correct, adjust or replace the cartridge in the pressure reducing valve (See Note 1).
6	6	Service Brakes (*See Note 2) (S/N 0654 & Before)	425 ± 25 psi (29,3 ± 1,7 bar)	With engine at idle depress the service brakes and check pressure. If pressure is not correct, adjust or replace the cartridge in the pressure reducing valve (See Note 1).
7	N/A	Load Sense	Variable 0 to 2,950 psi (0 to 203,3 bar)	With engine at idle operate a specific function (Boom, Frame Tilt, Attachment Tilt, Auxiliary or Steering) and check pressure.
9	N/A	Service Brakes (S/N 0655 thru 1167)	350 ± 25 psi (24,1 ± 1,7 bar)	With engine at idle depress the service brakes and check pressure. If pressure is not correct, recheck pressure reducing valve pressure.

10042 Hydraulic Diagram (S/N 1168 thru 2194)

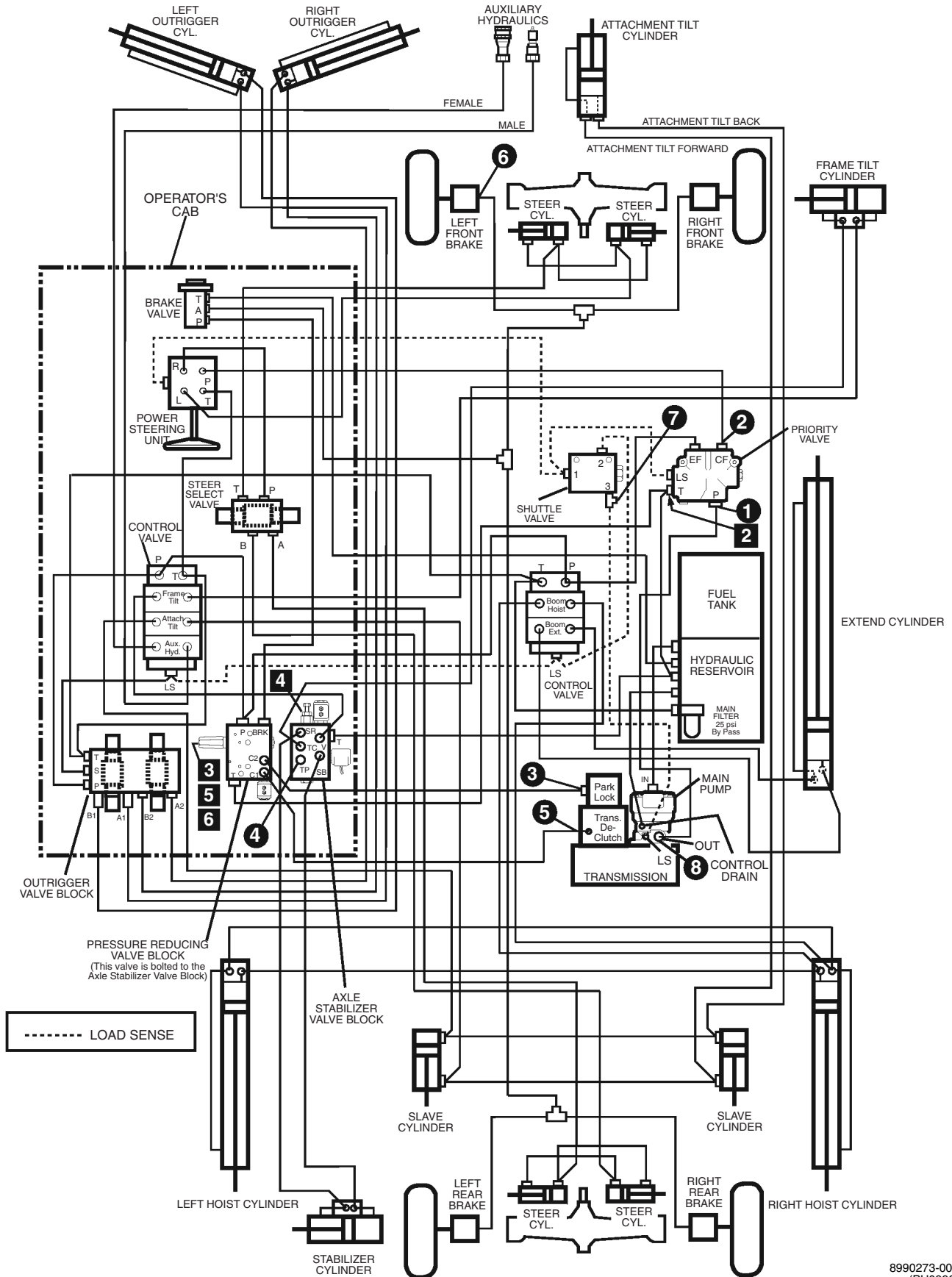

10042 Hydraulic Testing (S/N 1168 thru 2194)

Engine Information

Idle 1,050 ± 50 rpm
Full Speed 2,730 ± 130 rpm

Hydraulic Oil Information

Oil Type - 10W, meets MIL-L-2104C or ISO Grade 46
Capacity - Reservoir 30.3 gal. (114,7 liter)
Capacity - System 47.3 gal. (179 liter)

Note: To adjust relief settings or pressure reducing settings, turn the adjustment screw clockwise to increase pressure or counterclockwise to decrease pressure.

Equipment Needed To Perform Tests From Kit P/N 7118782

Circuit	Gauge	Fittings
1	4,000 PSI Gauge (275,6 bar)	#12 Run Tee Swivel Nut End Reducer #12-8 PD38TX Test Nipple
2	4,000 PSI Gauge (275,6 bar)	#8 Run Tee Swivel Nut PD38TX Test Nipple
3 5	1,000 PSI Gauge (68,9 bar)	#4 Union PD34BTX Test Nipple
4	300 PSI Gauge (20,7 bar)	Connector STR. THD. #4 PD34BTX Test Nipple
6	1,000 PSI Gauge (68,9 bar)	#4 Run Tee Swivel Nut PD34BTX Test Nipple
7	4,000 PSI Gauge (275,6 bar)	#6 Elbow 90° Swivel Nut PD36BTX Test Nipple

TEST LOCATION	Hydraulic Pump Flow Test
8	To check flow readings a flow meter capable of measuring 60 GPM (3,8 ltr/sec) and a load valve capable of 6,000 psi (413,4 bar) will be required (not included with kit P/N 7118782). 2,000 psi (137,8 bar) load @ Engine Speed of 2,500 ± 25 rpm — Flow rate should be 39 to 43 GPM (2,5 to 2,7 ltr/sec)

TEST LOCATION	ADJUST. LOCATION	COMPONENT DESCRIPTION	PRESSURE READINGS	PRESSURE TEST PROCEDURES
1	N/A	Pump Standby Pressure	550 ± 50 psi (37,9 ± 3,4 bar)	Loosen load sense line at location 7 to bleed off pressure and then retighten line. With engine at idle and all hydraulic functions in neutral position, check pump standby pressure.
	N/A	Pump Pressure Compensator	2,950 ± 50 psi (203,3 ± 3,4 bar)	With engine at idle fully retract boom extend cylinder and hold. Check pump maximum pressure.
2	2	Priority Valve Steering Relief	2,500 ± 50 psi (172,3 ± 3,4 bar)	With engine at idle turn the steering wheel all the way to the left or right and hold while checking pressure. If pressure is not correct, adjust (inside of "T" port) or replace the relief valve cartridge in the priority valve (See Note).
N/A	N/A	Attachment Tilt Port Relief	3,150 ± 50 psi (217 ± 3,4 bar)	CONSULT FACTORY
3	3	Pressure Reducing Valve In Pressure Reducing Valve Block And Park Brake Release	500 +25/-0 psi (34,5 +1,7/-0 bar)	With engine at idle and park brake released check pressure. If pressure is not correct, adjust or replace the cartridge in the pressure reducing valve (See Note).
4	4	Pressure Reducing Valve In Axle Stabilizer Valve Block	60 ± 10 psi (4,1 ± 0,7 bar)	With engine at idle and boom in the down position check pressure. If pressure is not correct, adjust or replace the cartridge in the axle stabilizer valve (See Note).
	N/A	Relief Check Valve In Axle Stabilizer Valve Block	100 psi Minimum (6,9 bar)	With engine at idle and boom down, while frame tilting to the left check pressure.
5	5	Transmission De-Clutch	500 +25/-0 psi (34,5 +1,7/-0 bar)	With engine at idle and park brake engaged check pressure. If pressure is not correct, adjust or replace the cartridge in the pressure reducing valve (See Note).
6	6	Service Brakes	500 +25/-0 psi (34,5 +1,7/-0 bar)	With engine at idle depress the service brakes and check pressure. If pressure is not correct, adjust or replace the cartridge in the pressure reducing valve (See Note).
7	N/A	Load Sense	Variable 0 to 2,950 psi (0 to 203,3 bar)	With engine at idle operate a specific function (Boom, Frame Tilt, Attachment Tilt, Auxiliary or Steering) and check pressure.

10042 Hydraulic Diagram (S/N 2195 thru 9908)

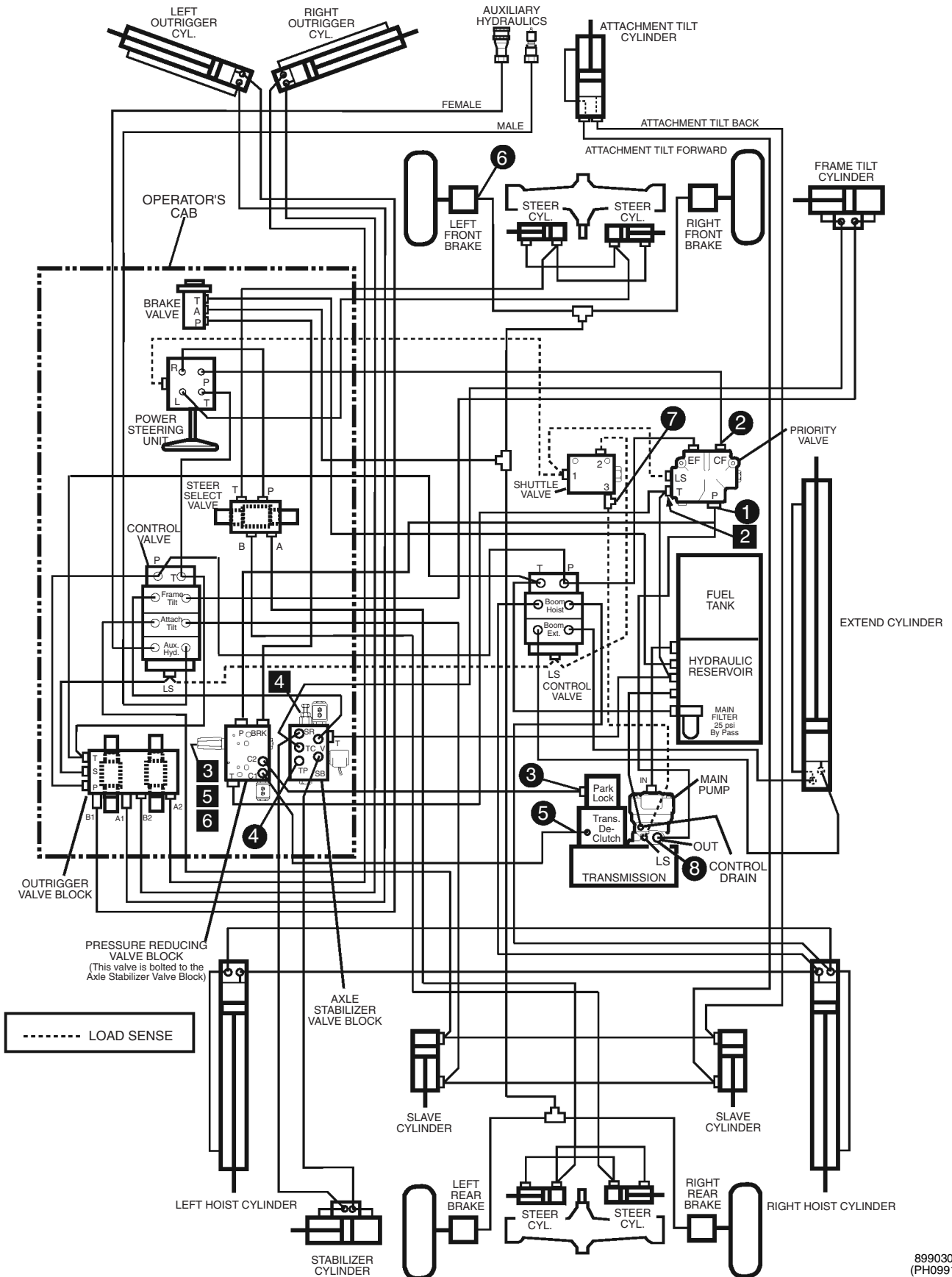

8990308
(PH0991)

10042 Hydraulic Testing (S/N 2195 thru 9908)

Engine Information

Idle 1,050 ± 50 rpm
Full Speed 2,730 ± 130 rpm

Hydraulic Oil Information

Oil Type - 10W, meets MIL-L-2104C or ISO Grade 46
Capacity - Reservoir 30.3 gal. (114,7 liter)
Capacity - System 47.3 gal. (179 liter)

Note: To adjust relief settings or pressure reducing settings, turn the adjustment screw clockwise to increase pressure or counterclockwise to decrease pressure.

The hydraulic oil temperature for the pump flow test should be between 100° F (38° C) and 120° F (49° C) (tank hot to the touch) during testing.

Equipment Needed To Perform Tests From Kit P/N 7118782

Circuit	Gauge	Fittings
1	4,000 PSI Gauge (275,6 bar)	#12 Run Tee Swivel Nut End Reducer #12-8 PD38TX Test Nipple
2	4,000 PSI Gauge (275,6 bar)	#8 Run Tee Swivel Nut PD38TX Test Nipple
3 5	1,000 PSI Gauge (68,9 bar)	#4 Union PD34BTX Test Nipple
4	1,000 PSI Gauge (68,9 bar)	Connector STR. THD. #4 PD34BTX Test Nipple
6	1,000 PSI Gauge (68,9 bar)	#4 Run Tee Swivel Nut PD34BTX Test Nipple
7	4,000 PSI Gauge (275,6 bar)	#6 Elbow 90° Swivel Nut PD36BTX Test Nipple

TEST LOCATION	Hydraulic Pump Flow Test
8	To check flow readings a flow meter capable of measuring 60 GPM (3,8 ltr/sec) and a load valve capable of 6,000 psi (413,4 bar) will be required (not included with kit P/N 7118782). 2,000 psi (137,8 bar) load @ Engine Speed of 2,500 ± 25 rpm — Flow rate should be 39 to 43 GPM (2,5 to 2,7 ltr/sec)

TEST LOCATION	ADJUST. LOCATION	COMPONENT DESCRIPTION	PRESSURE READINGS	PRESSURE TEST PROCEDURES
1	N/A	Pump Standby Pressure	550 ± 50 psi (37,9 ± 3,4 bar)	Loosen load sense line at location 7 to bleed off pressure and then retighten line. With engine at idle and all hydraulic functions in neutral position, check pump standby pressure.
	N/A	Pump Pressure Compensator	2,950 ± 50 psi (203,3 ± 3,4 bar)	With engine at idle fully retract boom extend cylinder and hold. Check pump maximum pressure.
2	2	Priority Valve Steering Relief	2,500 ± 50 psi (172,3 ± 3,4 bar)	With engine at idle turn the steering wheel all the way to the left or right and hold while checking pressure. If pressure is not correct, adjust (inside of "T" port) or replace the relief valve cartridge in the priority valve (See Note).
N/A	N/A	Attachment Tilt Port Relief	3,150 ± 50 psi (217 ± 3,4 bar)	CONSULT FACTORY
3	3	Pressure Reducing Valve In Pressure Reducing Valve Block And Park Brake Release	500 +25/-0 psi (34,5 +1,7/-0 bar)	With engine at idle and park brake released check pressure. If pressure is not correct, adjust or replace the cartridge in the pressure reducing valve (See Note).
4	4	Pressure Reducing Valve In Axle Stabilizer Valve Block	200 ± 25 psi (13,8 ± 1,7 bar)	With engine at idle and boom in the down position check pressure. If pressure is not correct, adjust or replace the cartridge in the axle stabilizer valve (See Note).
	N/A	Pressure Reducing Valve In Axle Stabilizer Valve Block	275 psi Maximum (18,9 bar)	With engine at idle and boom down, while frame tilting to the left check pressure. If pressure is not correct, recheck adjustment location 4. If that pressure is correct, replace the cartridge in the axle stabilizer valve.
5	5	Transmission De-Clutch	500 +25/-0 psi (34,5 +1,7/-0 bar)	With engine at idle and park brake engaged check pressure. If pressure is not correct, adjust or replace the cartridge in the pressure reducing valve (See Note).
6	6	Service Brakes	500 +25/-0 psi (34,5 +1,7/-0 bar)	With engine at idle depress the service brakes and check pressure. If pressure is not correct, adjust or replace the cartridge in the pressure reducing valve (See Note).
7	N/A	Load Sense	Variable 0 to 2,950 psi (0 to 203,3 bar)	With engine at idle operate a specific function (Boom, Frame Tilt, Attachment Tilt, Auxiliary or Steering) and check pressure.

10042 Hydraulic Diagram (S/N 9909 & After)

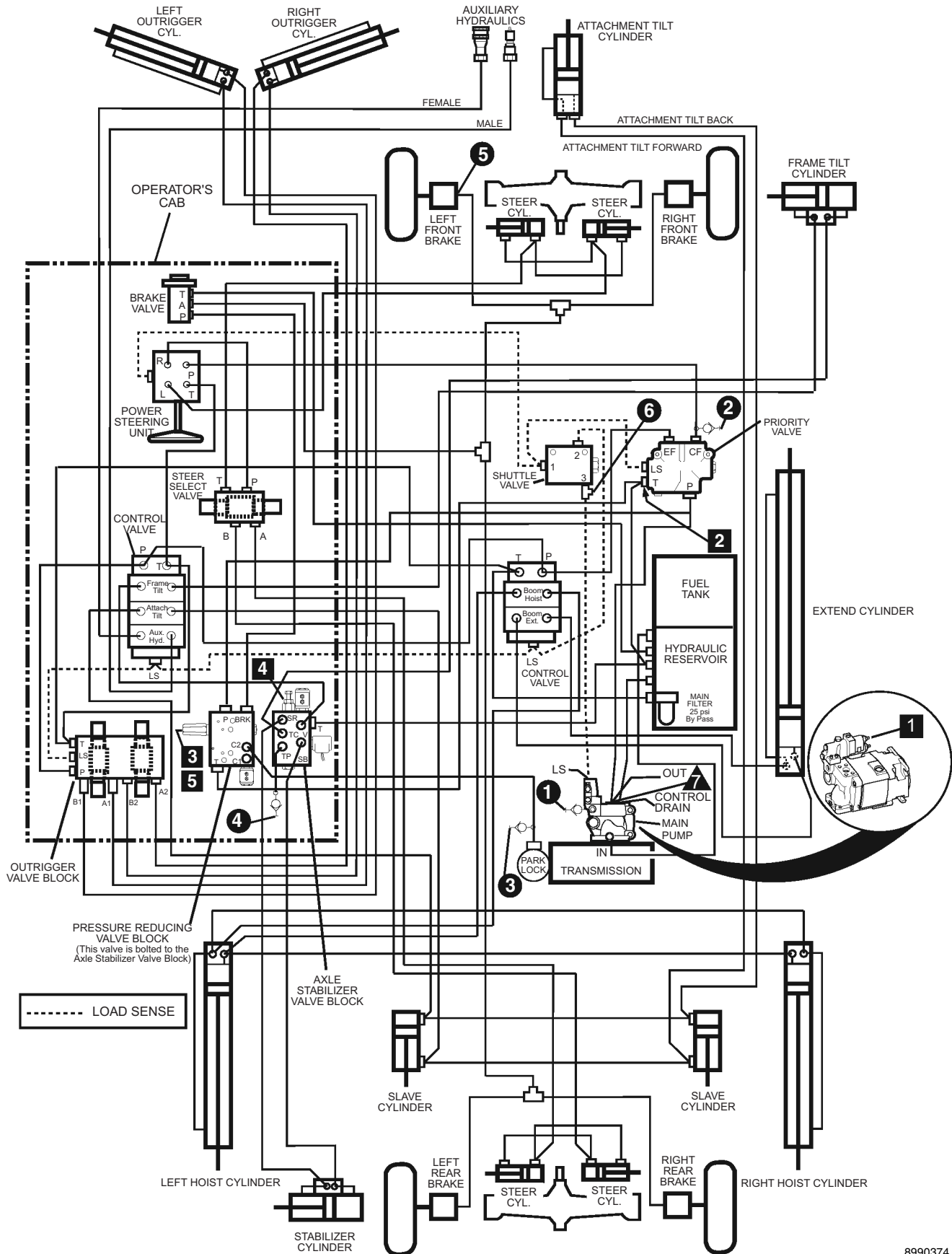

8990374
(PH1300)

10042 Hydraulic Testing (S/N 9909 & After)

Engine Information

Idle 1,050 ± 50 rpm
Full Speed 2,730 ± 130 rpm

Hydraulic Oil Information

Oil Type - 10W, meets MIL-L-2104C or ISO Grade 46
Capacity - Reservoir 30.3 gal. (114,7 liter)
Capacity - System 47.3 gal. (179 liter)

Note: To adjust relief settings, pressure reducing settings or standby pressure, turn the adjustment screw clockwise to increase pressure or counterclockwise to decrease pressure.

The hydraulic oil temperature for the pump flow test should be between 100° F (38° C) and 120° F (49° C) (tank hot to the touch) during testing.

Equipment Needed To Perform Tests From Kit P/N 7133413

Circuit	Gauge	Fittings
1	4,000 PSI Gauge (275,6 bar)	PD38TX Test Nipple
2	4,000 PSI Gauge (275,6 bar)	#8 Run Tee Swivel Nut PD38TX Test Nipple
3	1,000 PSI Gauge (68,9 bar)	#4 Union PD34BTX Test Nipple
4	1,000 PSI Gauge (68,9 bar)	Connector STR. THD. #4 PD34BTX Test Nipple
5	1,000 PSI Gauge (68,9 bar)	#4 Run Tee Swivel Nut PD34BTX Test Nipple
6	4,000 PSI Gauge (275,6 bar)	#6 Elbow 90° Swivel Nut PD36BTX Test Nipple

TEST LOCATION	Hydraulic Pump Flow Test
7	To check flow readings a flow meter capable of measuring 60 GPM (3,8 ltr/sec) and a load valve capable of 6,000 psi (413,4 bar) will be required (not included with kit P/N 7133413). A test nipple is supplied at location 7. 2,000 psi (137,8 bar) load @ Engine Speed of 2,500 ± 25 rpm — Flow rate should be 39 to 43 GPM (2,5 to 2,7 ltr/sec)

TEST LOCATION	ADJUST. LOCATION	COMPONENT DESCRIPTION	PRESSURE READINGS	PRESSURE TEST PROCEDURES
1	1	Pump Standby Pressure	550 ± 50 psi (37,9 ± 3,4 bar)	Loosen load sense line at location 6 to bleed off pressure and then retighten line. With engine at idle and all hydraulic functions in neutral position, check pump standby pressure (See Note).
	N/A	Pump Pressure Compensator	2,950 ± 50 psi (203,3 ± 3,4 bar)	With engine at idle fully retract boom extend cylinder and hold. Check pump maximum pressure.
2	2	Priority Valve Steering Relief	2,500 ± 50 psi (172,3 ± 3,4 bar)	With engine at idle turn the steering wheel all the way to the left or right and hold while checking pressure. If pressure is not correct, adjust (inside of "T" port) or replace the relief valve cartridge in the priority valve (See Note).
N/A	N/A	Attachment Tilt Port Relief	3,150 ± 50 psi (217 ± 3,4 bar)	CONSULT FACTORY
3	3	Pressure Reducing Valve In Pressure Reducing Valve Block And Park Brake Release	500 +25/-0 psi (34,5 +1,7/-0 bar)	With engine at idle and park brake released check pressure. If pressure is not correct, adjust or replace the cartridge in the pressure reducing valve (See Note).
4	4	Pressure Reducing Valve In Axle Stabilizer Valve Block	200 ± 25 psi (13,8 ± 1,7 bar)	With engine at idle and boom in the down position check pressure. If pressure is not correct, adjust or replace the cartridge in the axle stabilizer valve (See Note).
	N/A	Pressure Reducing Valve In Axle Stabilizer Valve Block	275 psi Maximum (18,9 bar)	With engine at idle and boom down, while frame tilting to the left check pressure. If pressure is not correct, recheck adjustment location 4. If that pressure is correct, replace the cartridge in the axle stabilizer valve.
5	5	Service Brakes	500 +25/-0 psi (34,5 +1,7/-0 bar)	With engine at idle depress the service brakes and check pressure. If pressure is not correct, adjust or replace the cartridge in the pressure reducing valve (See Note).
6	N/A	Load Sense	Variable 0 to 2,950 psi (0 to 203,3 bar)	With engine at idle operate a specific function (Boom, Frame Tilt, Attachment Tilt, Auxiliary or Steering) and check pressure.

10054 Hydraulic Diagram (S/N 1167 & Before)

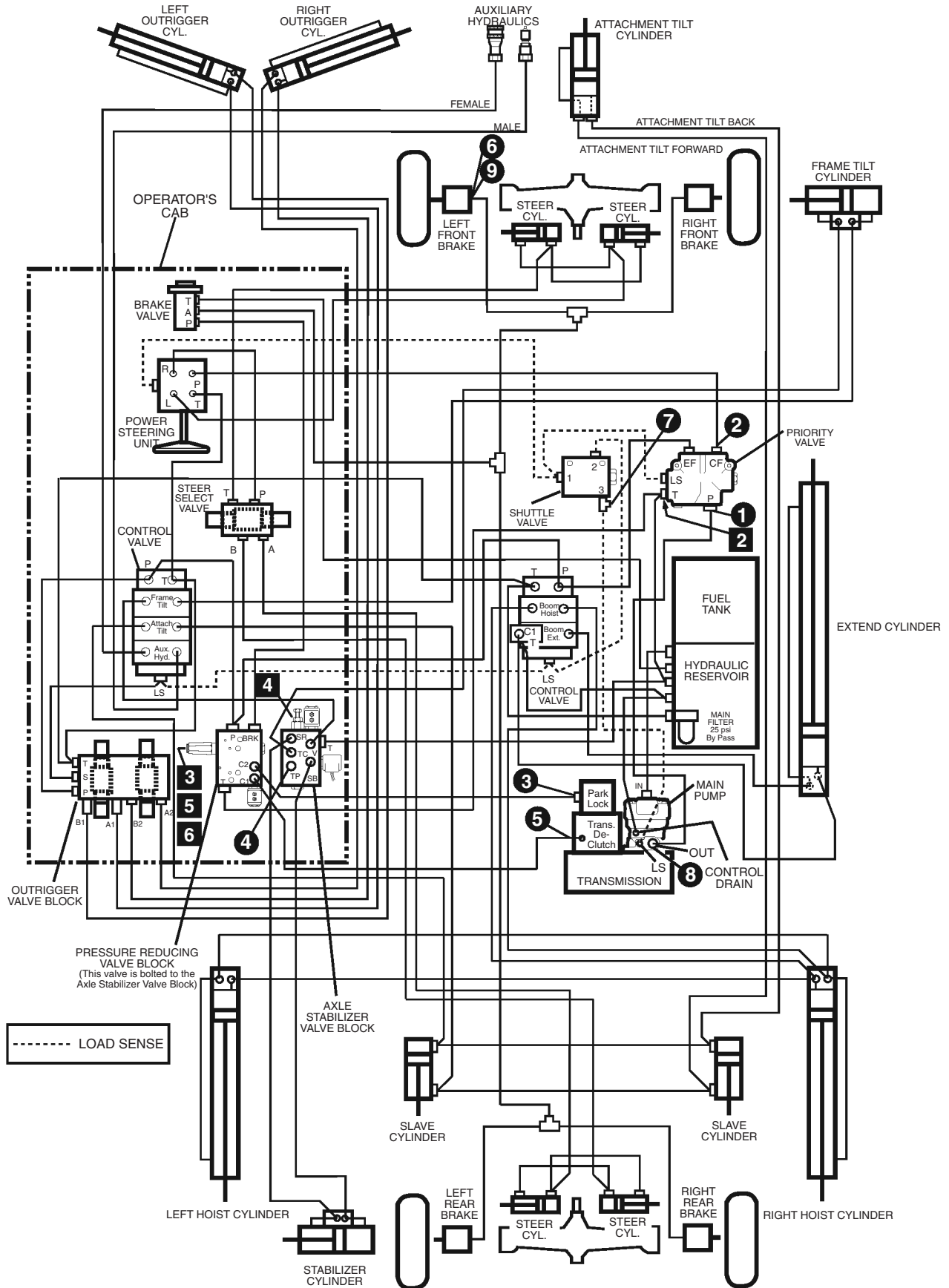

8990234-001
(MH0300)

10054 Hydraulic Testing (S/N 1167 & Before)

Engine Information

Idle 1,050 ± 50 rpm
Full Speed 2,730 ± 130 rpm

Hydraulic Oil Information

Oil Type - 10W, meets MIL-L-2104C or ISO Grade 46
Capacity - Reservoir 30.3 gal. (114,7 liter)
Capacity - System 59.5 gal. (225,2 liter)

Note 1: To adjust relief settings or pressure reducing settings, turn the adjustment screw clockwise to increase pressure or counterclockwise to decrease pressure.

***Note 2:** On units with S/N 0654 & Before. If the low brake pressure kit has been installed, as offered in Service Bulletin STB-2076, issued 5-29-95, refer to test location 9.

The hydraulic oil temperature for the pump flow test should be between 100° F (38° C) and 120° F (49° C) (tank hot to the touch) during testing.

Equipment Needed To Perform Tests From Kit P/N 7118782

Circuit	Gauge	Fittings
1	4,000 PSI Gauge (275,6 bar)	#12 Run Tee Swivel Nut End Reducer #12-8 PD38TX Test Nipple
2	4,000 PSI Gauge (275,6 bar)	#8 Run Tee Swivel Nut PD38TX Test Nipple
3 5	1,000 PSI Gauge (68,9 bar)	#4 Union PD34BTX Test Nipple
4	300 PSI Gauge (20,7 bar)	Connector STR. THD. #4 PD34BTX Test Nipple
6 9	1,000 PSI Gauge (68,9 bar)	#4 Run Tee Swivel Nut PD34BTX Test Nipple
7	4,000 PSI Gauge (275,6 bar)	#6 Elbow 90° Swivel Nut PD36BTX Test Nipple

TEST LOCATION	Hydraulic Pump Flow Test
8	To check flow readings a flow meter capable of measuring 60 GPM (3,8 ltr/sec) and a load valve capable of 6,000 psi (413,4 bar) will be required (not included with kit P/N 7118782). 2,000 psi (137,8 bar) load @ Engine Speed of 2,500 ± 25 rpm — Flow rate should be 39 to 43 GPM (2,5 to 2,7 ltr/sec)

TEST LOCATION	ADJUST. LOCATION	COMPONENT DESCRIPTION	PRESSURE READINGS	PRESSURE TEST PROCEDURES
1	N/A	Pump Standby Pressure	550 ± 50 psi (37,9 ± 3,4 bar)	Loosen load sense line at location 7 to bleed off pressure and then retighten line. With engine at idle and all hydraulic functions in neutral position, check pump standby pressure.
	N/A	Pump Pressure Compensator	2,950 ± 50 psi (203,3 ± 3,4 bar)	With engine at idle fully retract boom extend cylinder and hold. Check pump maximum pressure.
2	2	Priority Valve Steering Relief	2,500 ± 50 psi (172,3 ± 3,4 bar)	With engine at idle turn the steering wheel all the way to the left or right and hold while checking pressure. If pressure is not correct, adjust or replace the relief valve cartridge in the priority valve (See Note 1).
N/A	N/A	Attachment Tilt Port Relief	3,150 ± 50 psi (217 ± 3,4 bar)	CONSULT FACTORY
3	3	Pressure Reducing Valve In Pressure Reducing Valve Block And Park Brake Release	425 ± 25 psi (29,3 ± 1,7 bar)	With engine at idle and park brake released check pressure. If pressure is not correct, adjust or replace the cartridge in the pressure reducing valve (See Note 1).
4	4	Pressure Reducing Valve In Axle Stabilizer Valve Block	60 ± 10 psi (4,1 ± 0,7 bar)	With engine at idle and boom in the down position check pressure. If pressure is not correct, adjust or replace the cartridge in the axle stabilizer valve (See Note 1).
	N/A	Relief Check Valve In Axle Stabilizer Valve Block	100 psi Minimum (6,9 bar)	With engine at idle and boom down, while frame tilting to the left check pressure.
5	5	Transmission De-Clutch	425 ± 25 psi (29,3 ± 1,7 bar)	With engine at idle and park brake engaged check pressure. If pressure is not correct, adjust or replace the cartridge in the pressure reducing valve (See Note 1).
6	6	Service Brakes (*See Note 2) (S/N 0654 & Before)	425 ± 25 psi (29,3 ± 1,7 bar)	With engine at idle depress the service brakes and check pressure. If pressure is not correct, adjust or replace the cartridge in the pressure reducing valve (See Note 1).
7	N/A	Load Sense	Variable 0 to 2,950 psi (0 to 203,3 bar)	With engine at idle operate a specific function (Boom, Frame Tilt, Attachment Tilt, Auxiliary or Steering) and check pressure.
9	N/A	Service Brakes (S/N 0655 thru 1167)	350 ± 25 psi (24,1 ± 1,7 bar)	With engine at idle depress the service brakes and check pressure. If pressure is not correct, recheck pressure reducing valve pressure.

10054 Hydraulic Diagram (S/N 1168 thru 2194)

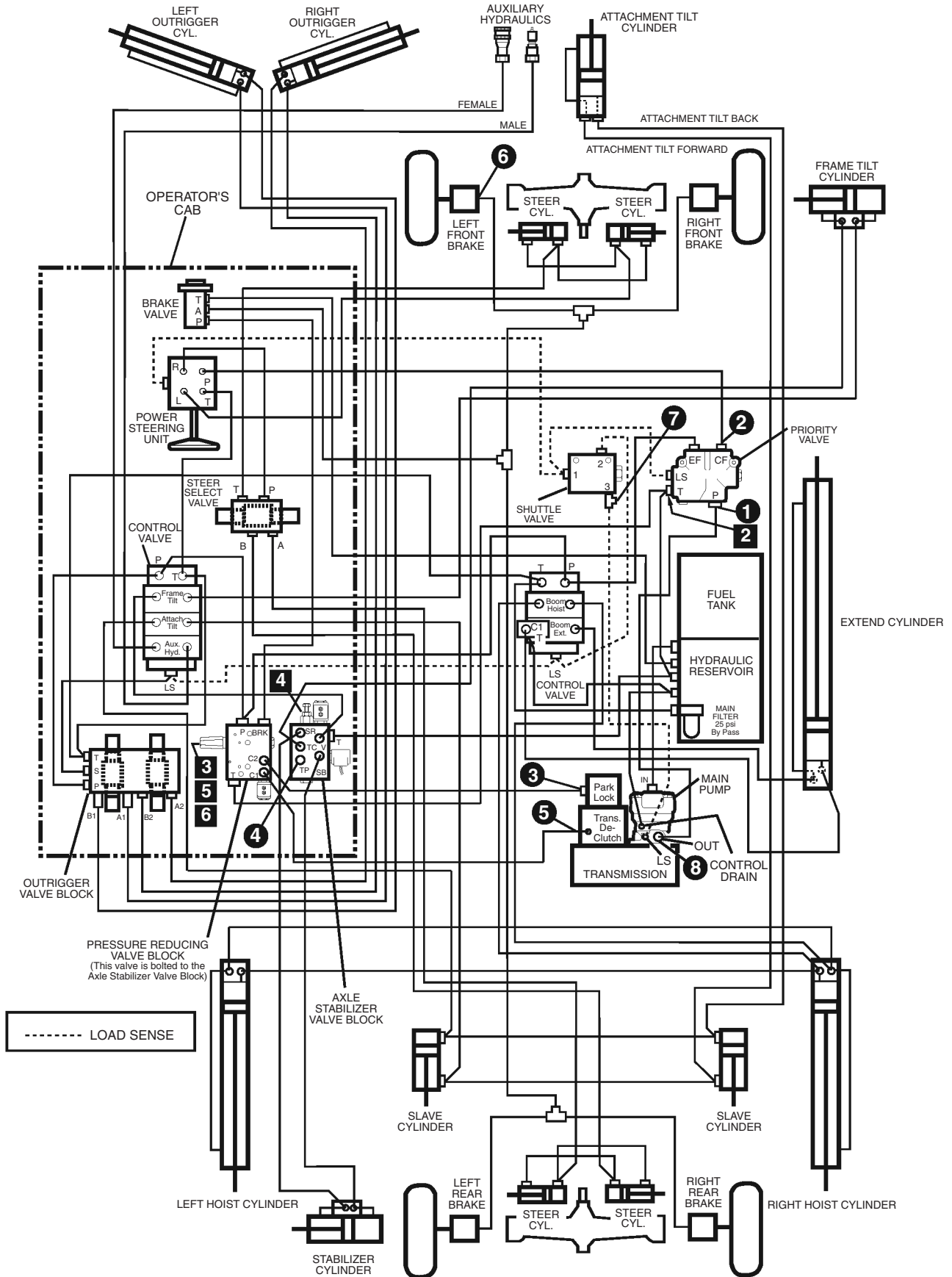

8990274-001 (PH1000)

10054 Hydraulic Testing (S/N 1168 thru 2194)

Engine Information

Idle 1,050 ± 50 rpm
Full Speed 2,730 ± 130 rpm

Hydraulic Oil Information

Oil Type - 10W, meets MIL-L-2104C or ISO Grade 46
Capacity - Reservoir 30.3 gal. (114,7 liter)
Capacity - System 59.5 gal. (225,2 liter)

Note: To adjust relief settings or pressure reducing settings, turn the adjustment screw clockwise to increase pressure or counterclockwise to decrease pressure.

The hydraulic oil temperature for the pump flow test should be between 100° F (38° C) and 120° F (49° C) (tank hot to the touch) during testing.

Equipment Needed To Perform Tests From Kit P/N 7118782

Circuit	Gauge	Fittings
1	4,000 PSI Gauge (275,6 bar)	#12 Run Tee Swivel Nut End Reducer #12-8 PD38TX Test Nipple
2	4,000 PSI Gauge (275,6 bar)	#8 Run Tee Swivel Nut PD38TX Test Nipple
3 5	1,000 PSI Gauge (68,9 bar)	#4 Union PD34BTX Test Nipple
4	300 PSI Gauge (20,7 bar)	Connector STR. THD. #4 PD34BTX Test Nipple
6	1,000 PSI Gauge (68,9 bar)	#4 Run Tee Swivel Nut PD34BTX Test Nipple
7	4,000 PSI Gauge (275,6 bar)	#6 Elbow 90° Swivel Nut PD36BTX Test Nipple

TEST LOCATION	Hydraulic Pump Flow Test
8	To check flow readings a flow meter capable of measuring 60 GPM (3,8 ltr/sec) and a load valve capable of 6,000 psi (413,4 bar) will be required (not included with kit P/N 7118782). 2,000 psi (137,8 bar) load @ Engine Speed of 2,500 ± 25 rpm — Flow rate should be 39 to 43 GPM (2,5 to 2,7 ltr/sec)

TEST LOCATION	ADJUST. LOCATION	COMPONENT DESCRIPTION	PRESSURE READINGS	PRESSURE TEST PROCEDURES
1	N/A	Pump Standby Pressure	550 ± 50 psi (37,9 ± 3,4 bar)	Loosen load sense line at location 7 to bleed off pressure and then retighten line. With engine at idle and all hydraulic functions in neutral position, check pump standby pressure.
	N/A	Pump Pressure Compensator	2,950 ± 50 psi (203,3 ± 3,4 bar)	With engine at idle fully retract boom extend cylinder and hold. Check pump maximum pressure.
2	2	Priority Valve Steering Relief	2,500 ± 50 psi (172,3 ± 3,4 bar)	With engine at idle turn the steering wheel all the way to the left or right and hold while checking pressure. If pressure is not correct, adjust (inside of "T" port) or replace the relief valve cartridge in the priority valve (See Note).
N/A	N/A	Attachment Tilt Port Relief	3,150 ± 50 psi (217 ± 3,4 bar)	CONSULT FACTORY
3	3	Pressure Reducing Valve In Pressure Reducing Valve Block And Park Brake Release	500 +25/-0 psi (34,5 +1,7/-0 bar)	With engine at idle and park brake released check pressure. If pressure is not correct, adjust or replace the cartridge in the pressure reducing valve (See Note).
4	4	Pressure Reducing Valve In Axle Stabilizer Valve Block	60 ± 10 psi (4,1 ± 0,7 bar)	With engine at idle and boom in the down position check pressure. If pressure is not correct, adjust or replace the cartridge in the axle stabilizer valve (See Note).
	N/A	Relief Check Valve In Axle Stabilizer Valve Block	100 psi Minimum (6,9 bar)	With engine at idle and boom down, while frame tilting to the left check pressure.
5	5	Transmission De-Clutch	500 +25/-0 psi (34,5 +1,7/-0 bar)	With engine at idle and park brake engaged check pressure. If pressure is not correct, adjust or replace the cartridge in the pressure reducing valve (See Note).
6	6	Service Brakes	500 +25/-0 psi (34,5 +1,7/-0 bar)	With engine at idle depress the service brakes and check pressure. If pressure is not correct, adjust or replace the cartridge in the pressure reducing valve (See Note).
7	N/A	Load Sense	Variable 0 to 2,950 psi (0 to 203,3 bar)	With engine at idle operate a specific function (Boom, Frame Tilt, Attachment Tilt, Auxiliary or Steering) and check pressure.

10054 Hydraulic Diagram (S/N 2195 thru 9908)

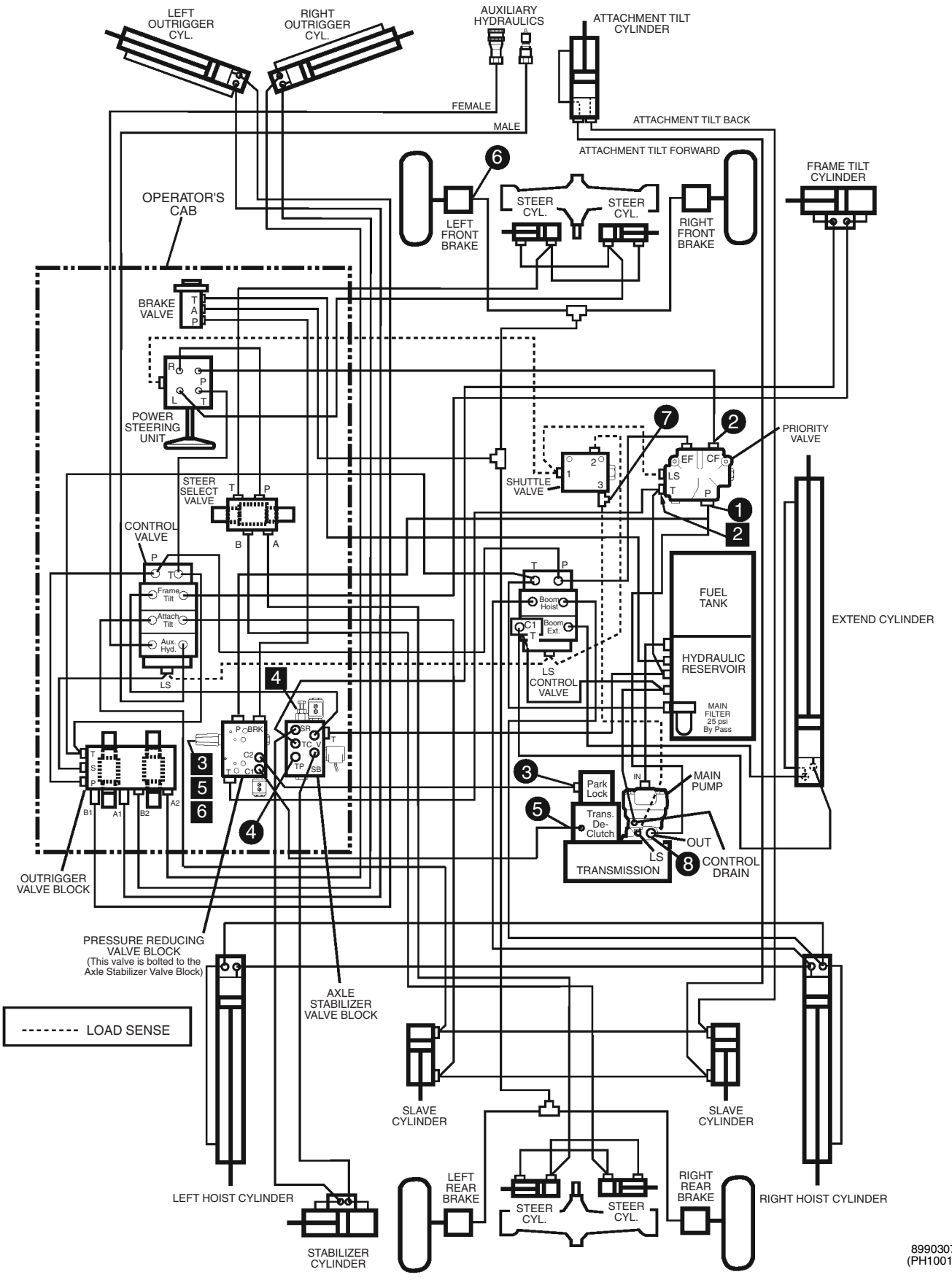

8990307
(PH1001)

10054 Hydraulic Testing (S/N 2195 thru 9908)

Engine Information

Idle 1,050 ± 50 rpm
Full Speed 2,730 ± 130 rpm

Hydraulic Oil Information

Oil Type - 10W, meets MIL-L-2104C or ISO Grade 46
Capacity - Reservoir 30.3 gal. (114,7 liter)
Capacity - System 59.5 gal. (225,2 liter)

Note: To adjust relief settings or pressure reducing settings, turn the adjustment screw clockwise to increase pressure or counterclockwise to decrease pressure.

The hydraulic oil temperature for the pump flow test should be between 100° F (38° C) and 120° F (49° C) (tank hot to the touch) during testing.

Equipment Needed To Perform Tests From Kit P/N 7118782

Circuit	Gauge	Fittings
1	4,000 PSI Gauge (275,6 bar)	#12 Run Tee Swivel Nut End Reducer #12-8 PD38TX Test Nipple
2	4,000 PSI Gauge (275,6 bar)	#8 Run Tee Swivel Nut PD38TX Test Nipple
3 5	1,000 PSI Gauge (68,9 bar)	#4 Union PD34BTX Test Nipple
4	1,000 PSI Gauge (68,9 bar)	Connector STR. THD. #4 PD34BTX Test Nipple
6	1,000 PSI Gauge (68,9 bar)	#4 Run Tee Swivel Nut PD34BTX Test Nipple
7	4,000 PSI Gauge (275,6 bar)	#6 Elbow 90° Swivel Nut PD36BTX Test Nipple

TEST LOCATION	Hydraulic Pump Flow Test
8	To check flow readings a flow meter capable of measuring 60 GPM (3,8 ltr/sec) and a load valve capable of 6,000 psi (413,4 bar) will be required (not included with kit P/N 7118782). 2,000 psi (137,8 bar) load @ Engine Speed of 2,500 ± 25 rpm — Flow rate should be 39 to 43 GPM (2,5 to 2,7 ltr/sec)

TEST LOCATION	ADJUST. LOCATION	COMPONENT DESCRIPTION	PRESSURE READINGS	PRESSURE TEST PROCEDURES
1	N/A	Pump Standby Pressure	550 ± 50 psi (37,9 ± 3,4 bar)	Loosen load sense line at location 7 to bleed off pressure and then retighten line. With engine at idle and all hydraulic functions in neutral position, check pump standby pressure.
	N/A	Pump Pressure Compensator	2,950 ± 50 psi (203,3 ± 3,4 bar)	With engine at idle fully retract boom extend cylinder and hold. Check pump maximum pressure.
2	2	Priority Valve Steering Relief	2,500 ± 50 psi (172,3 ± 3,4 bar)	With engine at idle turn the steering wheel all the way to the left or right and hold while checking pressure. If pressure is not correct, adjust (inside of "T" port) or replace the relief valve cartridge in the priority valve (See Note).
N/A	N/A	Attachment Tilt Port Relief	3,150 ± 50 psi (217 ± 3,4 bar)	CONSULT FACTORY
3	3	Pressure Reducing Valve In Pressure Reducing Valve Block And Park Brake Release	500 +25/-0 psi (34,5 +1,7/-0 bar)	With engine at idle and park brake released check pressure. If pressure is not correct, adjust or replace the cartridge in the pressure reducing valve (See Note).
4	4	Pressure Reducing Valve In Axle Stabilizer Valve Block	200 ± 25 psi (13,8 ± 1,7 bar)	With engine at idle and boom in the down position check pressure. If pressure is not correct, adjust or replace the cartridge in the axle stabilizer valve (See Note).
	N/A	Pressure Reducing Valve In Axle Stabilizer Valve Block	275 psi Maximum (18,9 bar)	With engine at idle and boom down, while frame tilting to the left check pressure. If pressure is not correct, recheck adjustment location 4. If that pressure is correct, replace the cartridge in the axle stabilizer valve.
5	5	Transmission De-Clutch	500 +25/-0 psi (34,5 +1,7/-0 bar)	With engine at idle and park brake engaged check pressure. If pressure is not correct, adjust or replace the cartridge in the pressure reducing valve (See Note).
6	6	Service Brakes	500 +25/-0 psi (34,5 +1,7/-0 bar)	With engine at idle depress the service brakes and check pressure. If pressure is not correct, adjust or replace the cartridge in the pressure reducing valve (See Note).
7	N/A	Load Sense	Variable 0 to 2,950 psi (0 to 203,3 bar)	With engine at idle operate a specific function (Boom, Frame Tilt, Attachment Tilt, Auxiliary or Steering) and check pressure.

10054 Hydraulic Diagram (S/N 9909 & After)

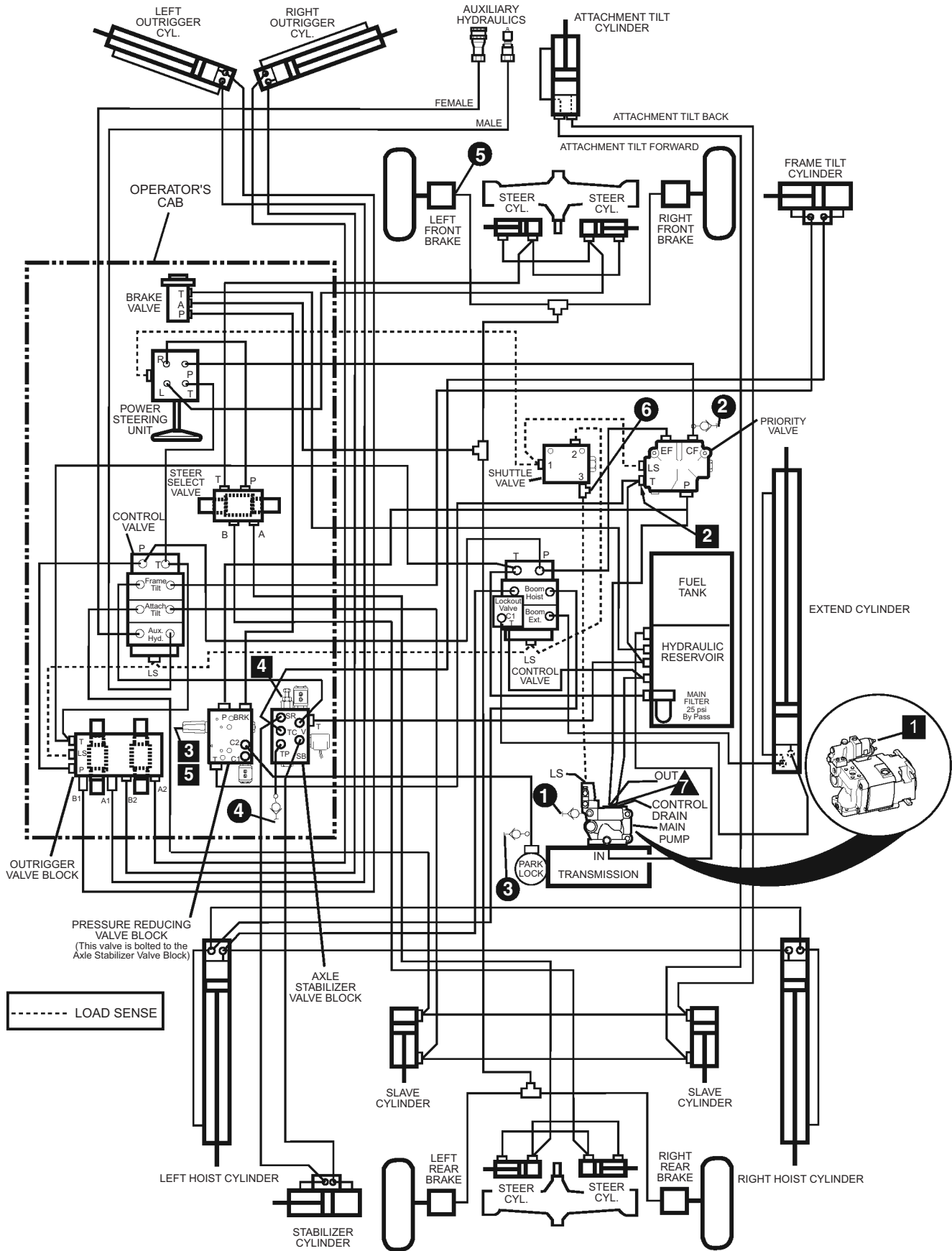

10054 Hydraulic Testing (S/N 9909 & After)

Engine Information

Idle 1,050 ± 50 rpm
Full Speed 2,730 ± 130 rpm

Hydraulic Oil Information

Oil Type - 10W, meets MIL-L-2104C or ISO Grade 46
Capacity - Reservoir 30.3 gal. (114,7 liter)
Capacity - System 59.5 gal. (225,2 liter)

Note: To adjust relief settings, pressure reducing settings or standby pressure, turn the adjustment screw clockwise to increase pressure or counterclockwise to decrease pressure.

The hydraulic oil temperature for the pump flow test should be between 100° F (38° C) and 120° F (49° C) (tank hot to the touch) during testing.

Equipment Needed To Perform Tests From Kit P/N 7133413

Circuit	Gauge	Fittings
1	4,000 PSI Gauge (275,6 bar)	PD38TX Test Nipple
2	4,000 PSI Gauge (275,6 bar)	#8 Run Tee Swivel Nut PD38TX Test Nipple
3	1,000 PSI Gauge (68,9 bar)	#4 Union PD34BTX Test Nipple
4	1,000 PSI Gauge (68,9 bar)	Connector STR. THD. #4 PD34BTX Test Nipple
5	1,000 PSI Gauge (68,9 bar)	#4 Run Tee Swivel Nut PD34BTX Test Nipple
6	4,000 PSI Gauge (275,6 bar)	#6 Elbow 90° Swivel Nut PD36BTX Test Nipple

TEST LOCATION	Hydraulic Pump Flow Test
7	<p>To check flow readings a flow meter capable of measuring 60 GPM (3,8 ltr/sec) and a load valve capable of 6,000 psi (413,4 bar) will be required (not included with kit P/N 7133413). A test nipple is supplied at location 7.</p> <p>2,000 psi (137,8 bar) load @ Engine Speed of 2,500 ± 25 rpm — Flow rate should be 39 to 43 GPM (2,5 to 2,7 ltr/sec)</p>

TEST LOCATION	ADJUST. LOCATION	COMPONENT DESCRIPTION	PRESSURE READINGS	PRESSURE TEST PROCEDURES
1	1	Pump Standby Pressure	550 ± 50 psi (37,9 ± 3,4 bar)	Loosen load sense line at location 6 to bleed off pressure and then retighten line. With engine at idle and all hydraulic functions in neutral position, check pump standby pressure (See Note).
	N/A	Pump Pressure Compensator	2,950 ± 50 psi (203,3 ± 3,4 bar)	With engine at idle fully retract boom extend cylinder and hold. Check pump maximum pressure.
2	2	Priority Valve Steering Relief	2,500 ± 50 psi (172,3 ± 3,4 bar)	With engine at idle turn the steering wheel all the way to the left or right and hold while checking pressure. If pressure is not correct, adjust (inside of "T" port) or replace the relief valve cartridge in the priority valve (See Note).
N/A	N/A	Attachment Tilt Port Relief	3,150 ± 50 psi (217 ± 3,4 bar)	CONSULT FACTORY
3	3	Pressure Reducing Valve In Pressure Reducing Valve Block And Park Brake Release	500 +25/-0 psi (34,5 +1,7/-0 bar)	With engine at idle and park brake released check pressure. If pressure is not correct, adjust or replace the cartridge in the pressure reducing valve (See Note).
4	4	Pressure Reducing Valve In Axle Stabilizer Valve Block	200 ± 25 psi (13,8 ± 1,7 bar)	With engine at idle and boom in the down position check pressure. If pressure is not correct, adjust or replace the cartridge in the axle stabilizer valve (See Note).
	N/A	Pressure Reducing Valve In Axle Stabilizer Valve Block	275 psi Maximum (18,9 bar)	With engine at idle and boom down, while frame tilting to the left check pressure. If pressure is not correct, recheck adjustment location 4 . If that pressure is correct, replace the cartridge in the axle stabilizer valve.
5	5	Service Brakes	500 +25/-0 psi (34,5 +1,7/-0 bar)	With engine at idle depress the service brakes and check pressure. If pressure is not correct, adjust or replace the cartridge in the pressure reducing valve (See Note).
6	N/A	Load Sense	Variable 0 to 2,950 psi (0 to 203,3 bar)	With engine at idle operate a specific function (Boom, Frame Tilt, Attachment Tilt, Auxiliary or Steering) and check pressure.

8042/10042/10054 Variable Volume Load Sensing Pump Flow Meter Diagram (S/N 9908 & Before)

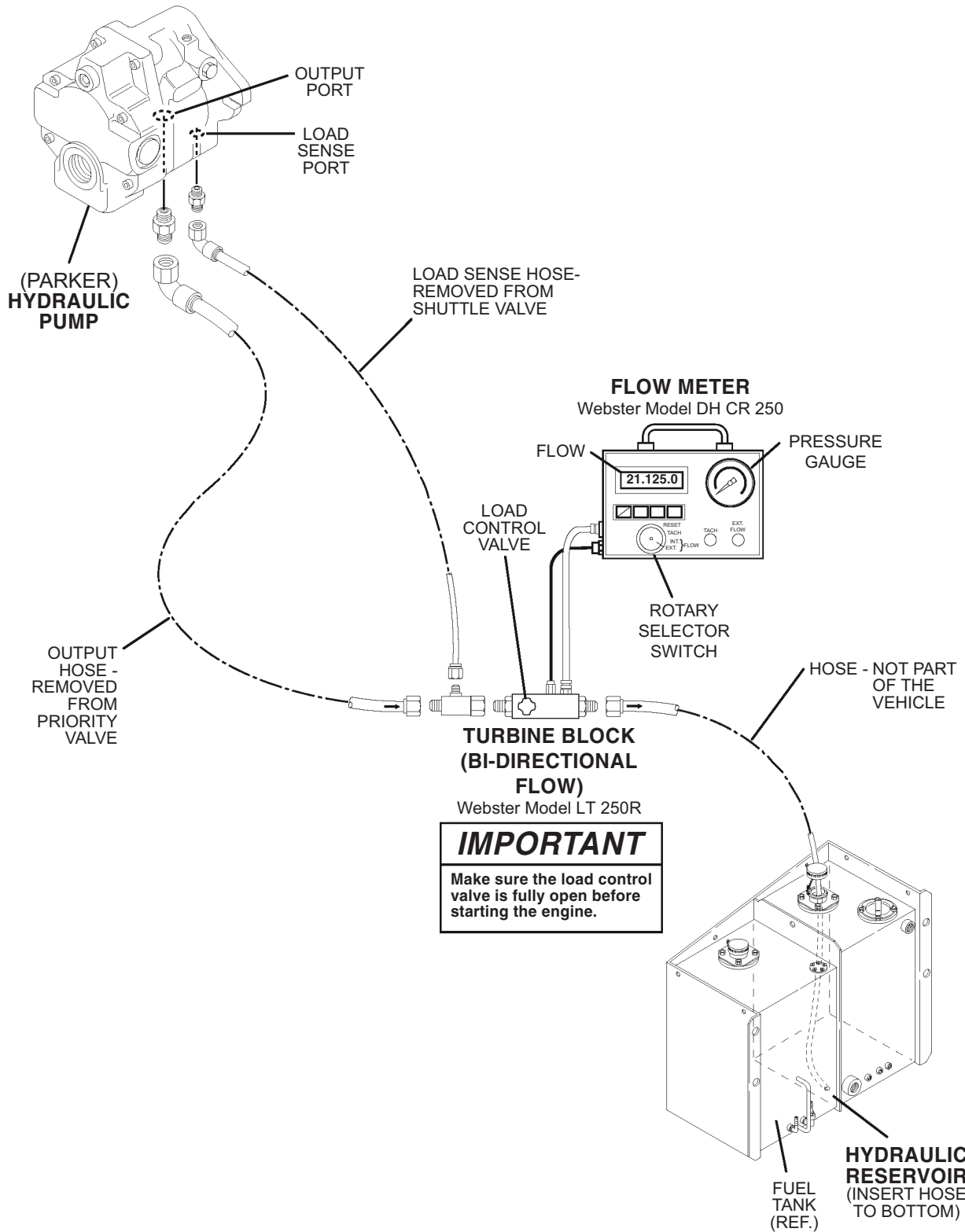

PH1320

8042/10042/10054 Variable Volume Load Sensing Pump Flow Meter Diagram (S/N 9909 & After)

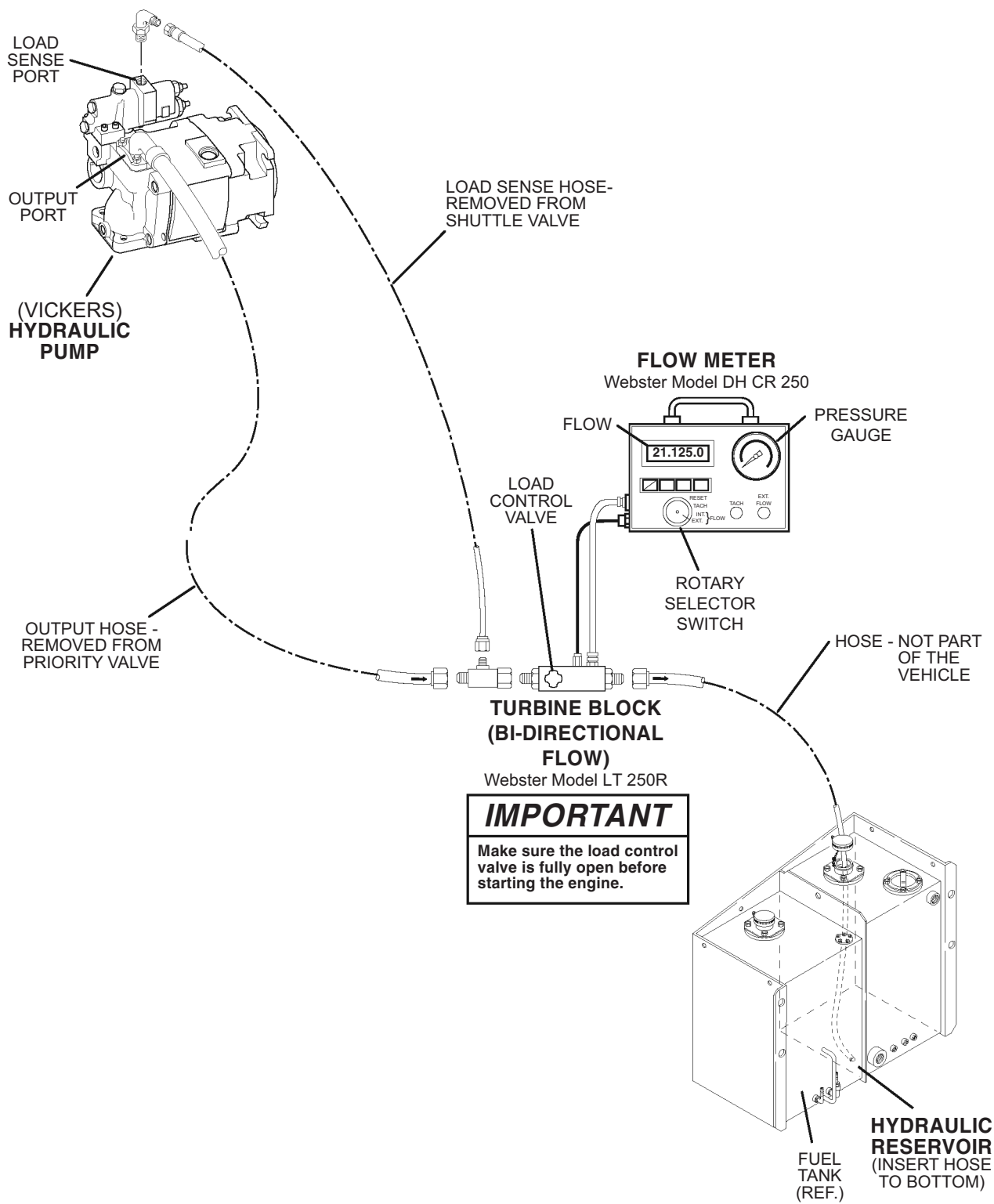

PH1321

8042/10042 Hoist and Extend Circuits (S/N 8540 & Before)

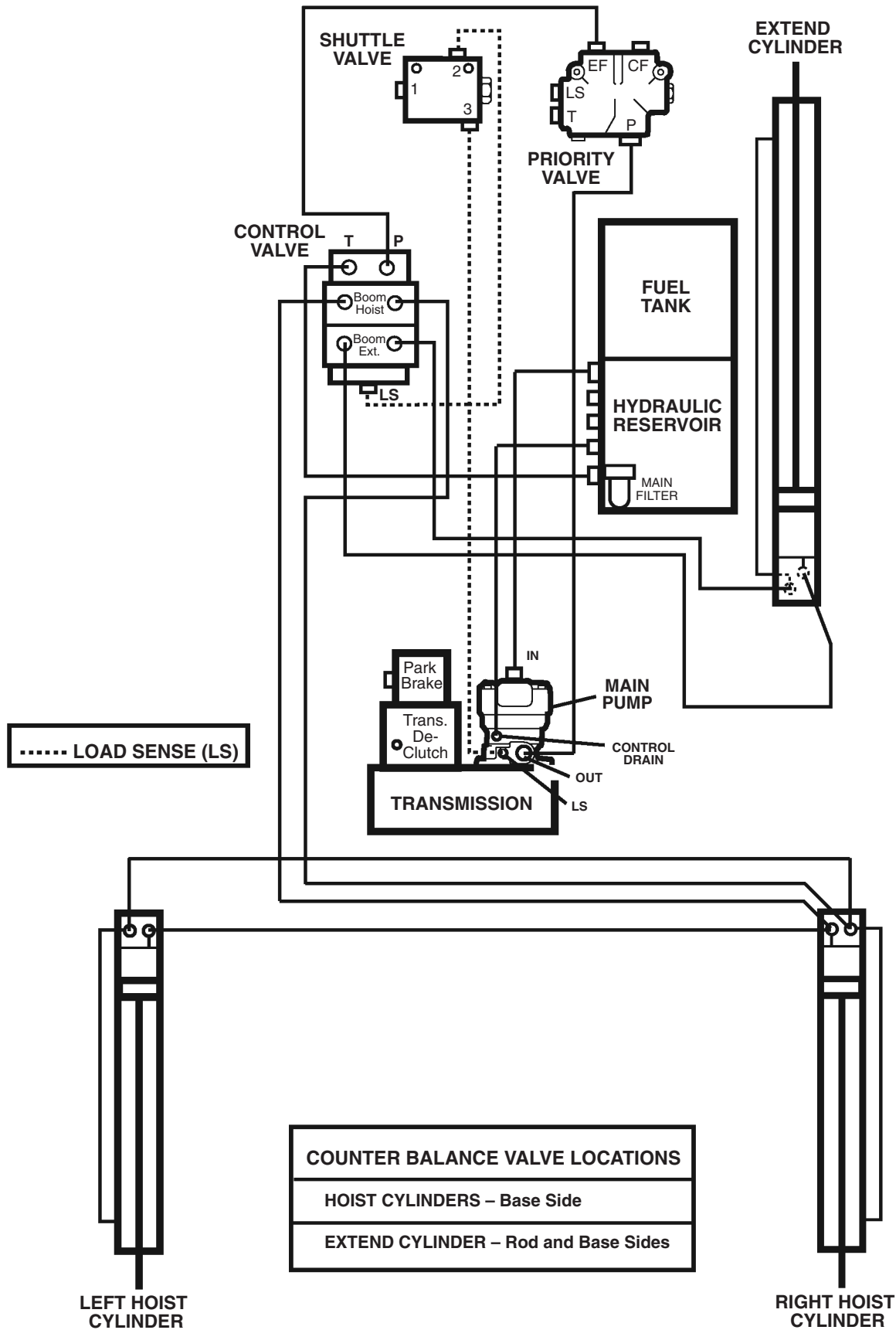

MH0091

8042/10042 Hoist and Extend Schematic (S/N 8540 & Before)

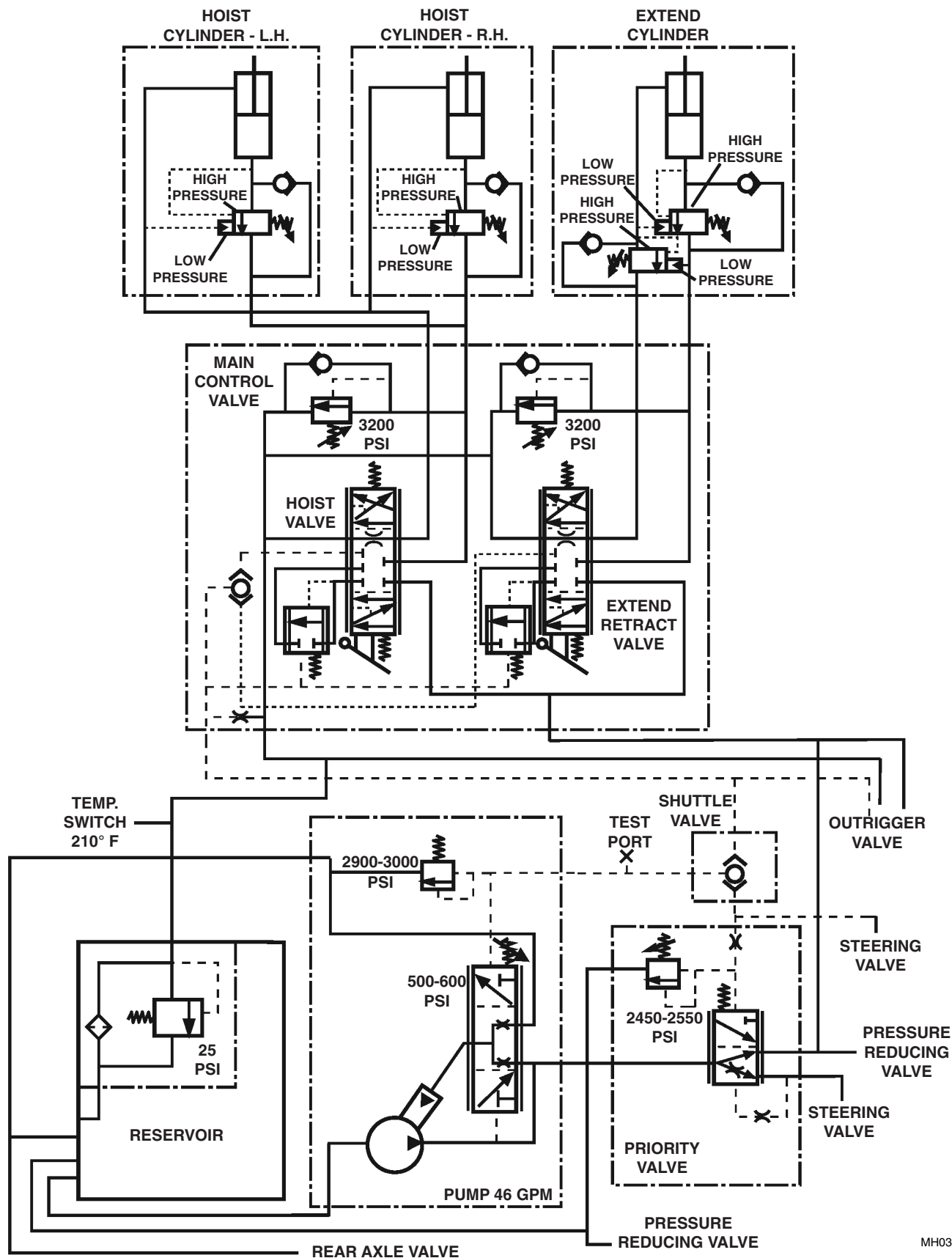

MH0312

8042/10042 Hoist and Extend Circuits (S/N 8541 thru 9908)

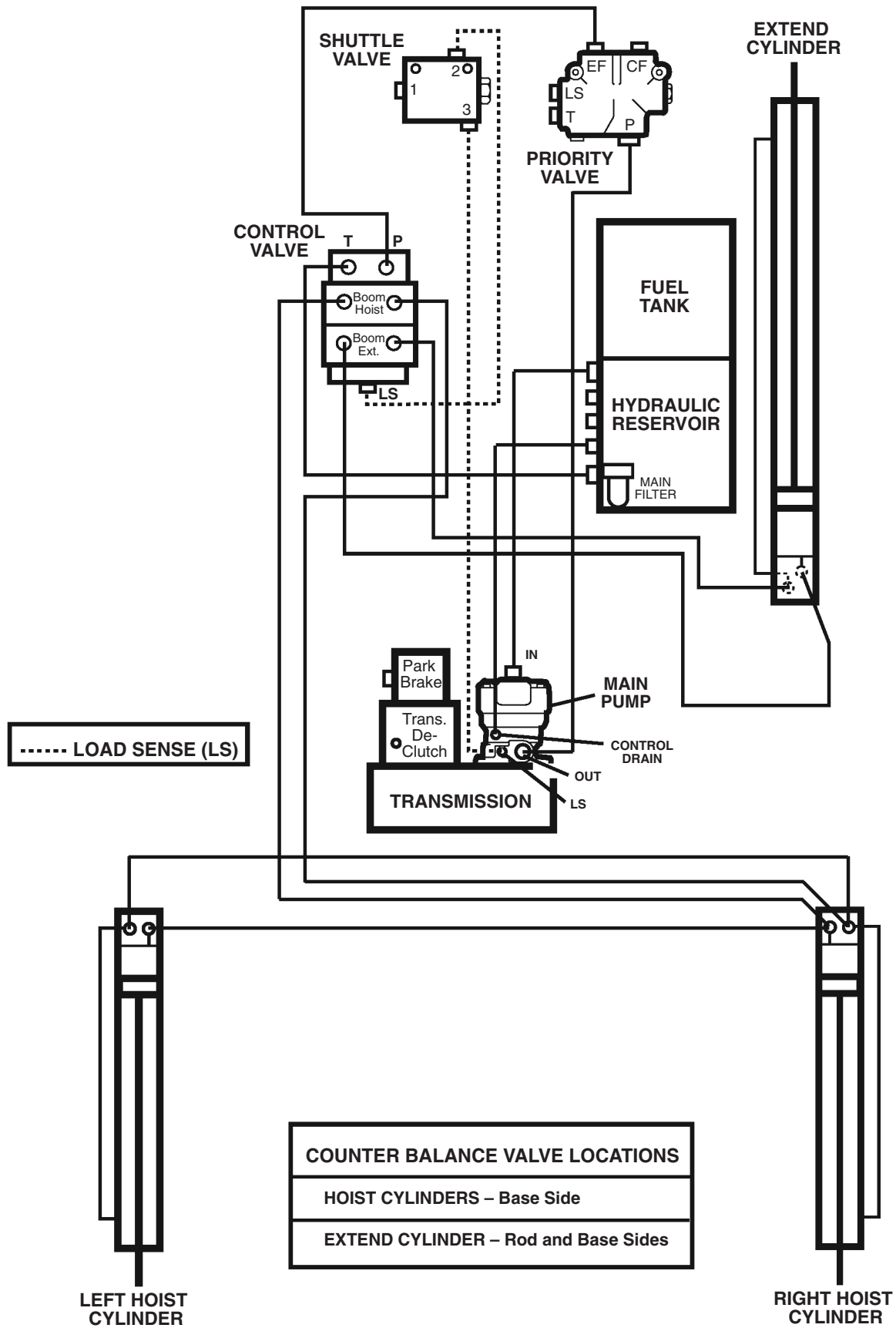

MH0091

8042/10042 Hoist and Extend Schematic (S/N 8541 thru 9908)

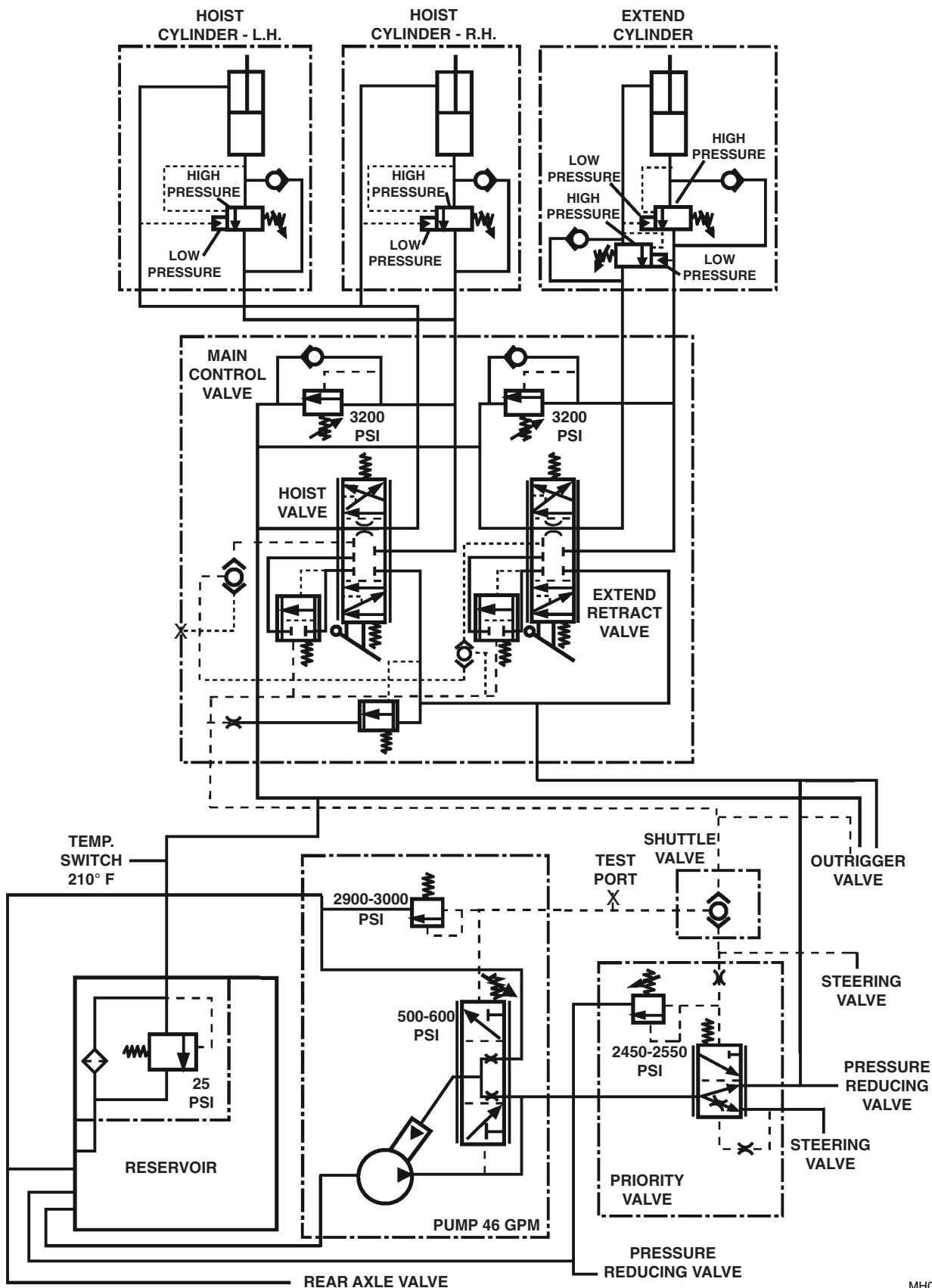

MH0620

8042/10042 Hoist and Extend Circuits (S/N 9909 & After)

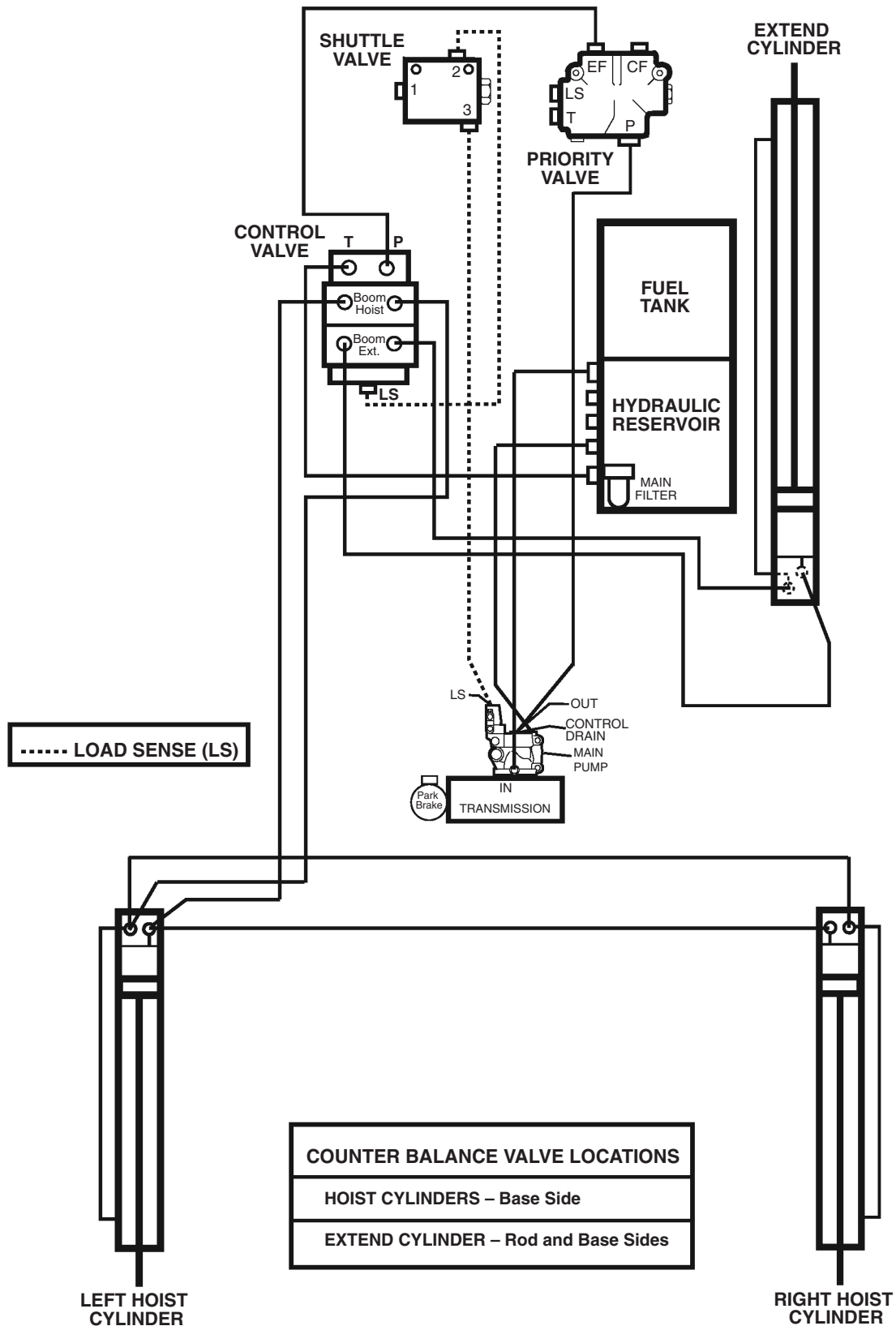

8042/10042 Hoist and Extend Schematic (S/N 9909 & After)

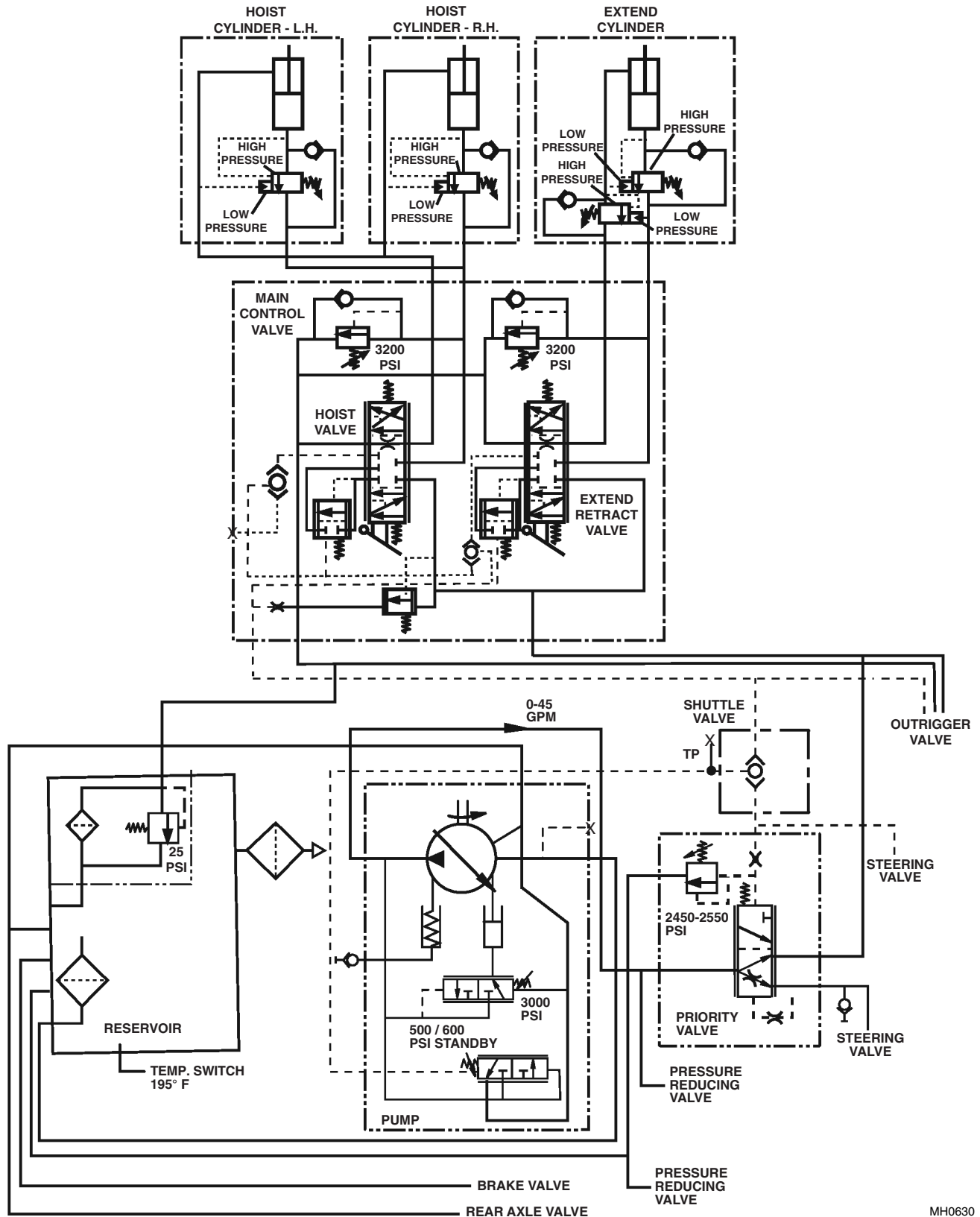

MH0630

10054 Hoist and Extend Circuits (S/N 8540 & Before)

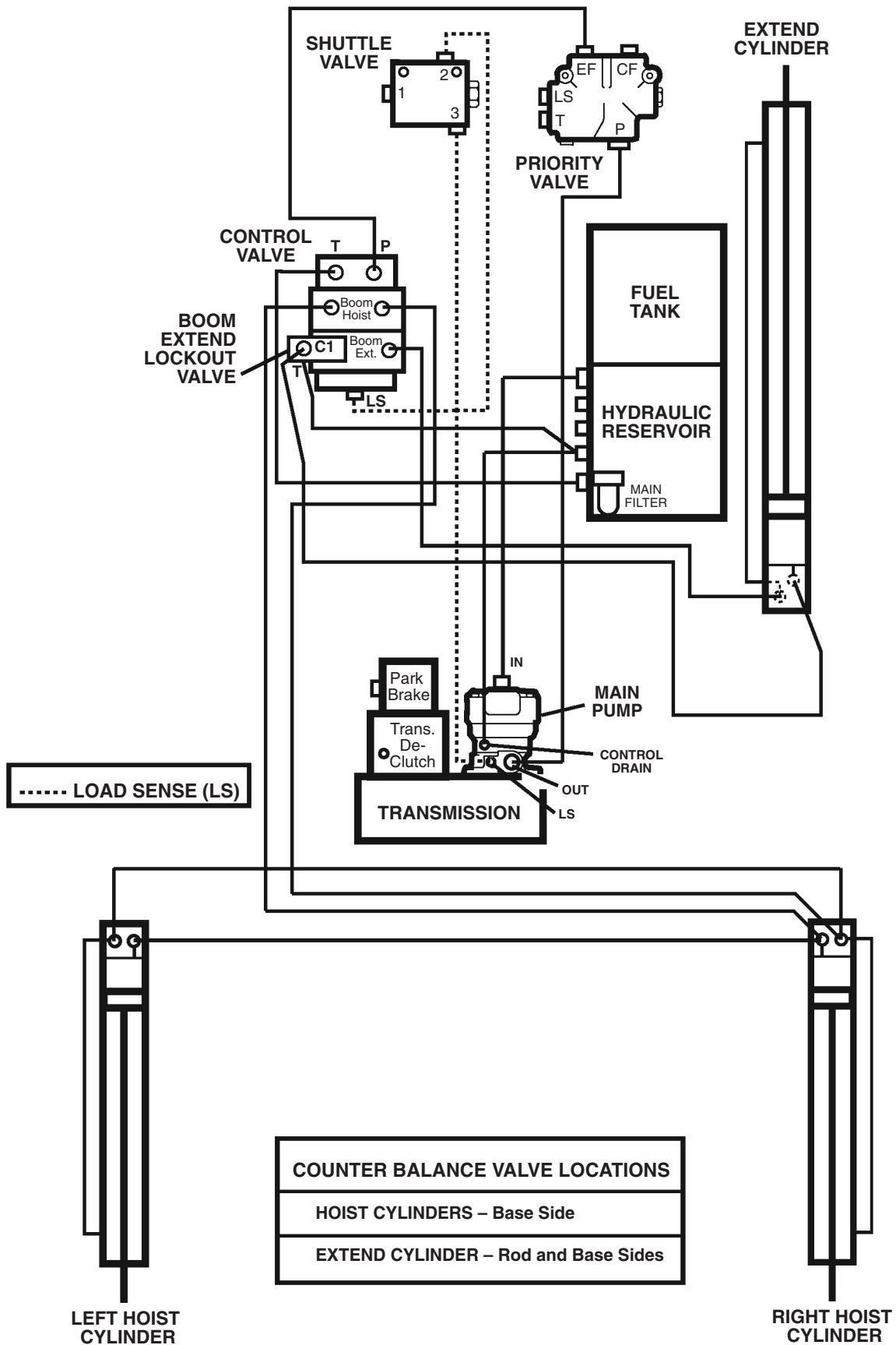

MH0101

10054 Hoist and Extend Schematic (S/N 8540 & Before)

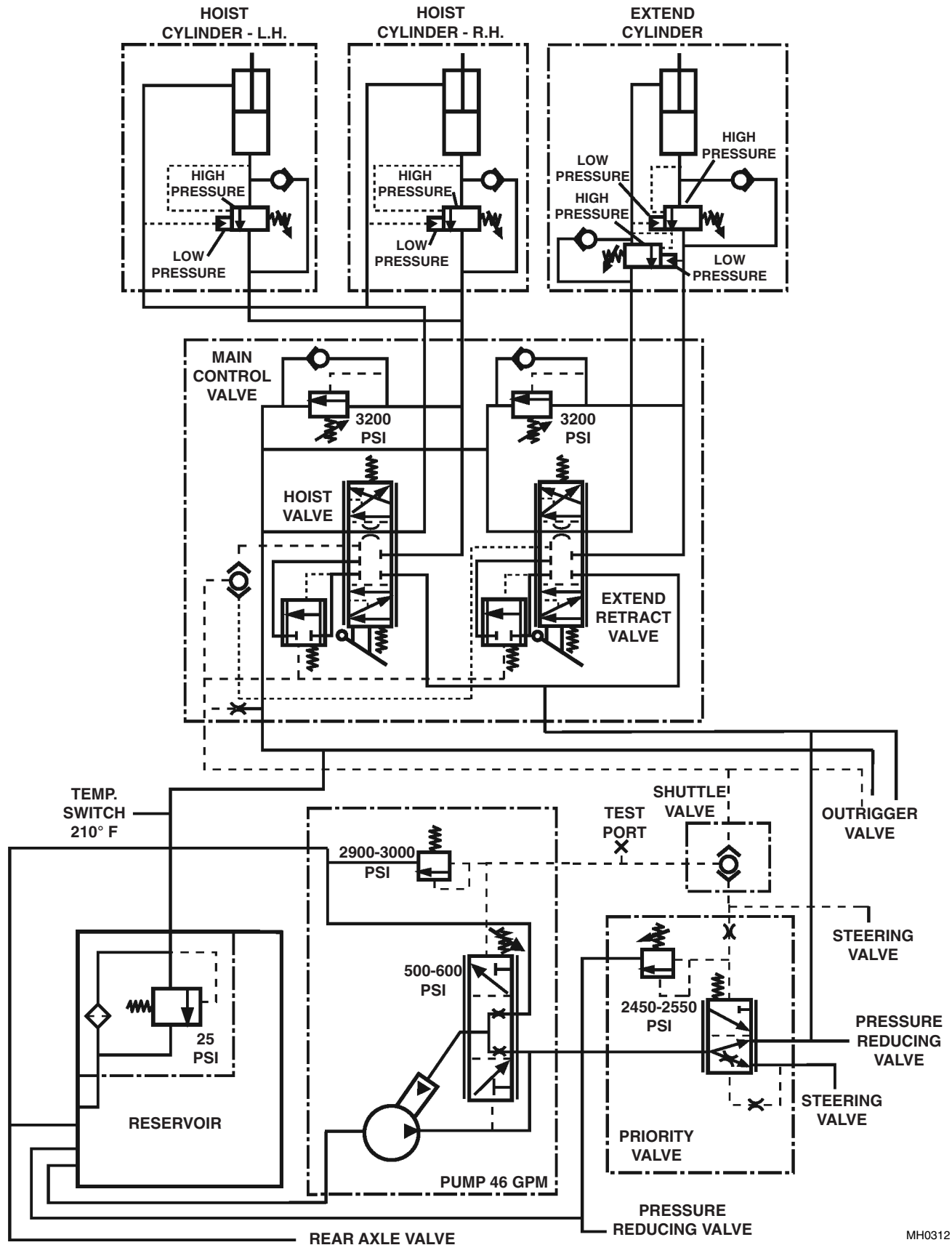

MH0312

10054 Hoist and Extend Circuits (S/N 8541 thru 9908)

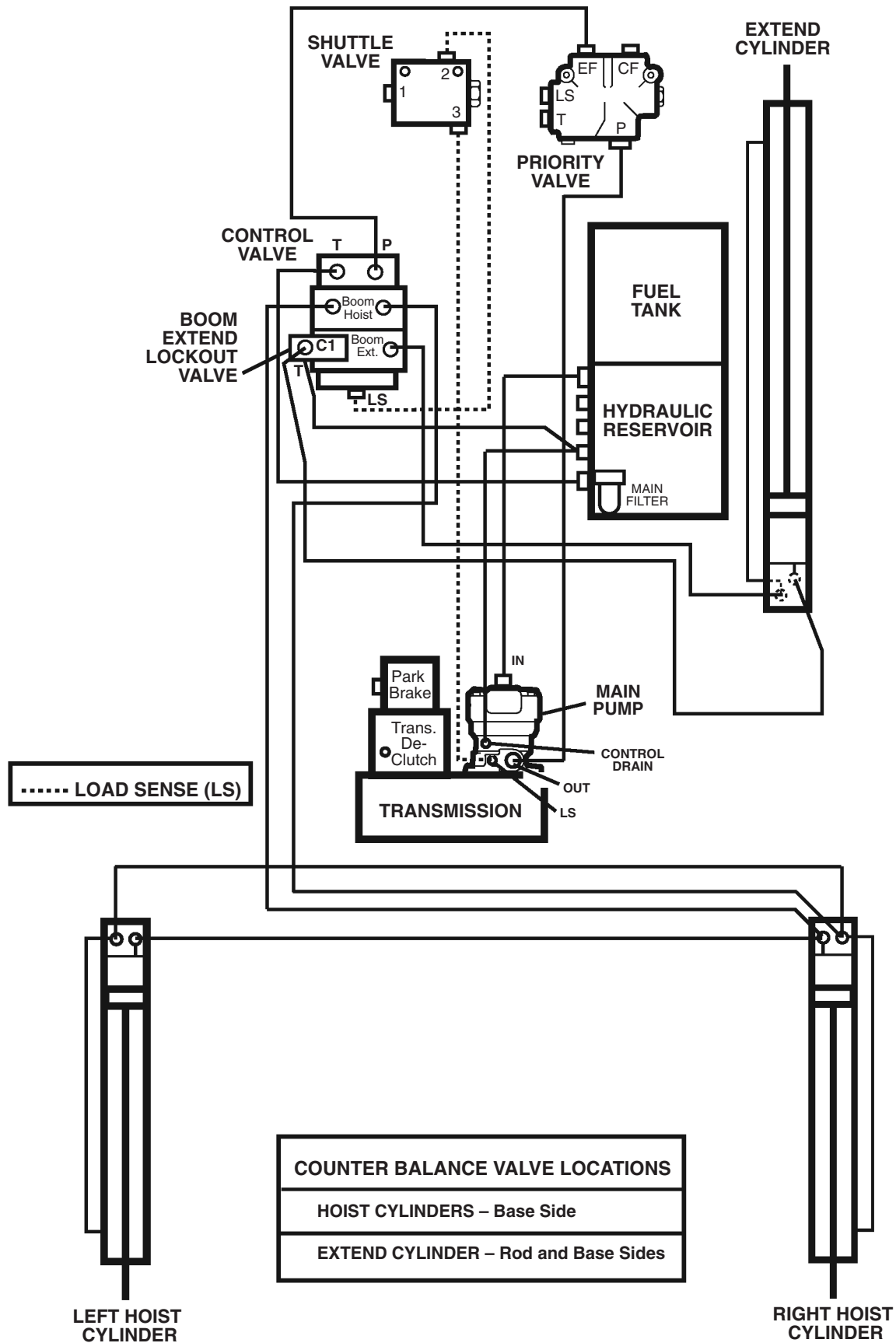

MH0101

10054 Hoist and Extend Schematic (S/N 8541 thru 9908)

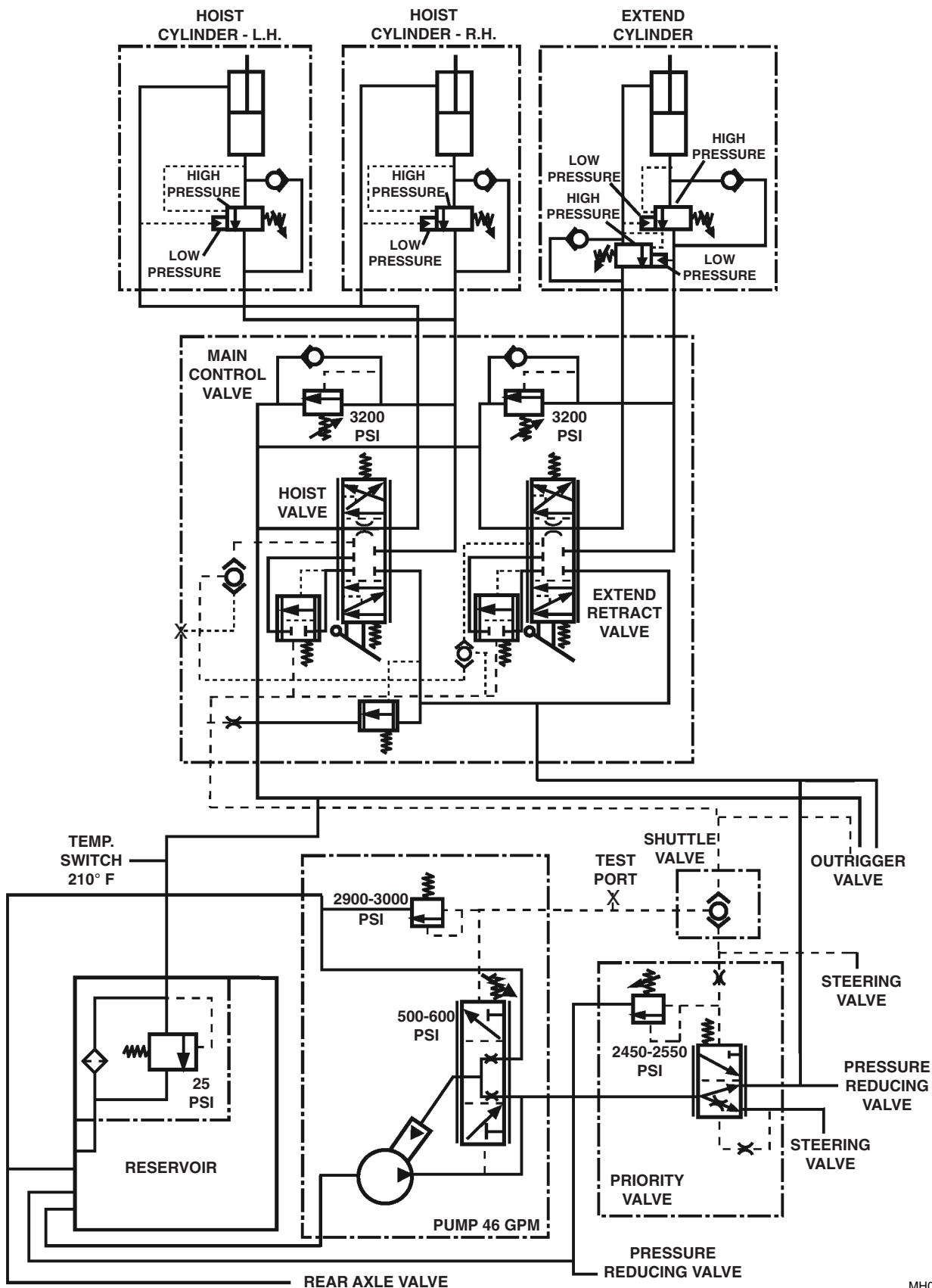

MH0620

10054 Hoist and Extend Circuits (S/N 9909 & After)

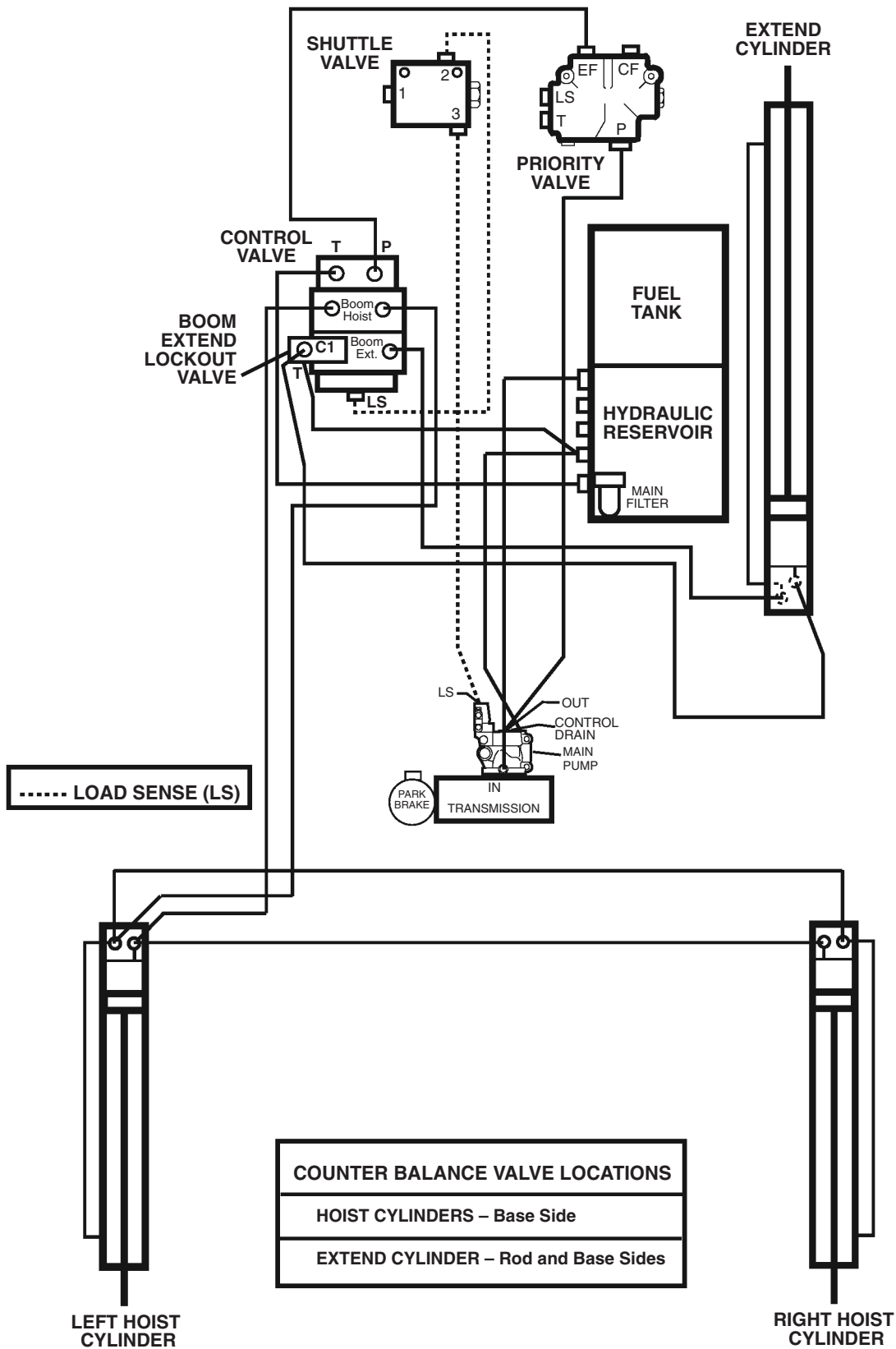

MH0570

10054 Hoist and Extend Schematic (S/N 9909 & After)

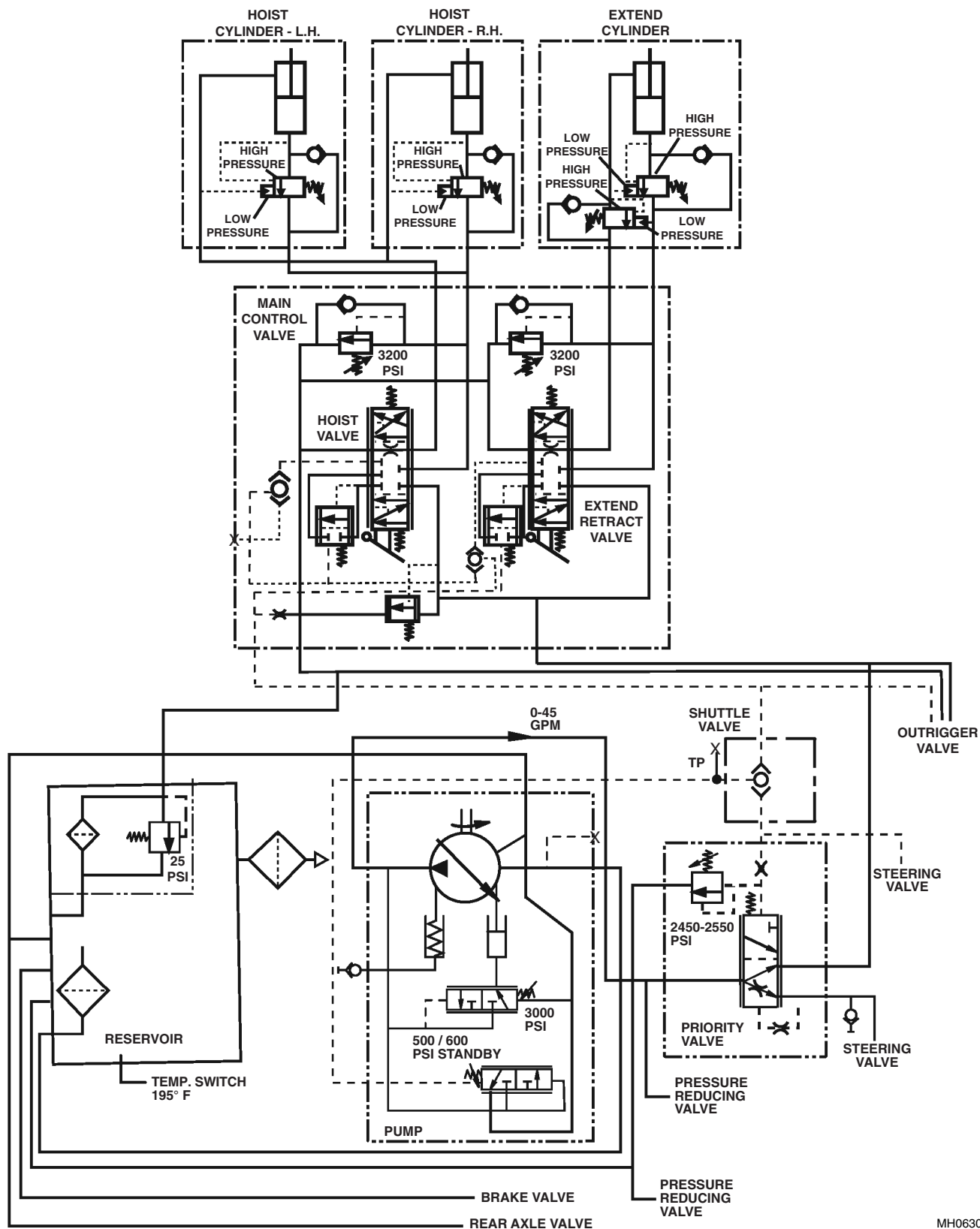

MH0630

8042/10042/10054 Frame Tilt, Attachment Tilt, Slave & Auxiliary Circuits (S/N 2194 & Before)

PILOT OPERATED CHECK VALVE LOCATIONS:	
FRAME TILT CYLINDER	- Rod & Base Sides
ATTACHMENT CYLINDER	- Base Side
COUNTER BALANCE VALVE LOCATION:	
ATTACHMET CYLINDER	- Base Side

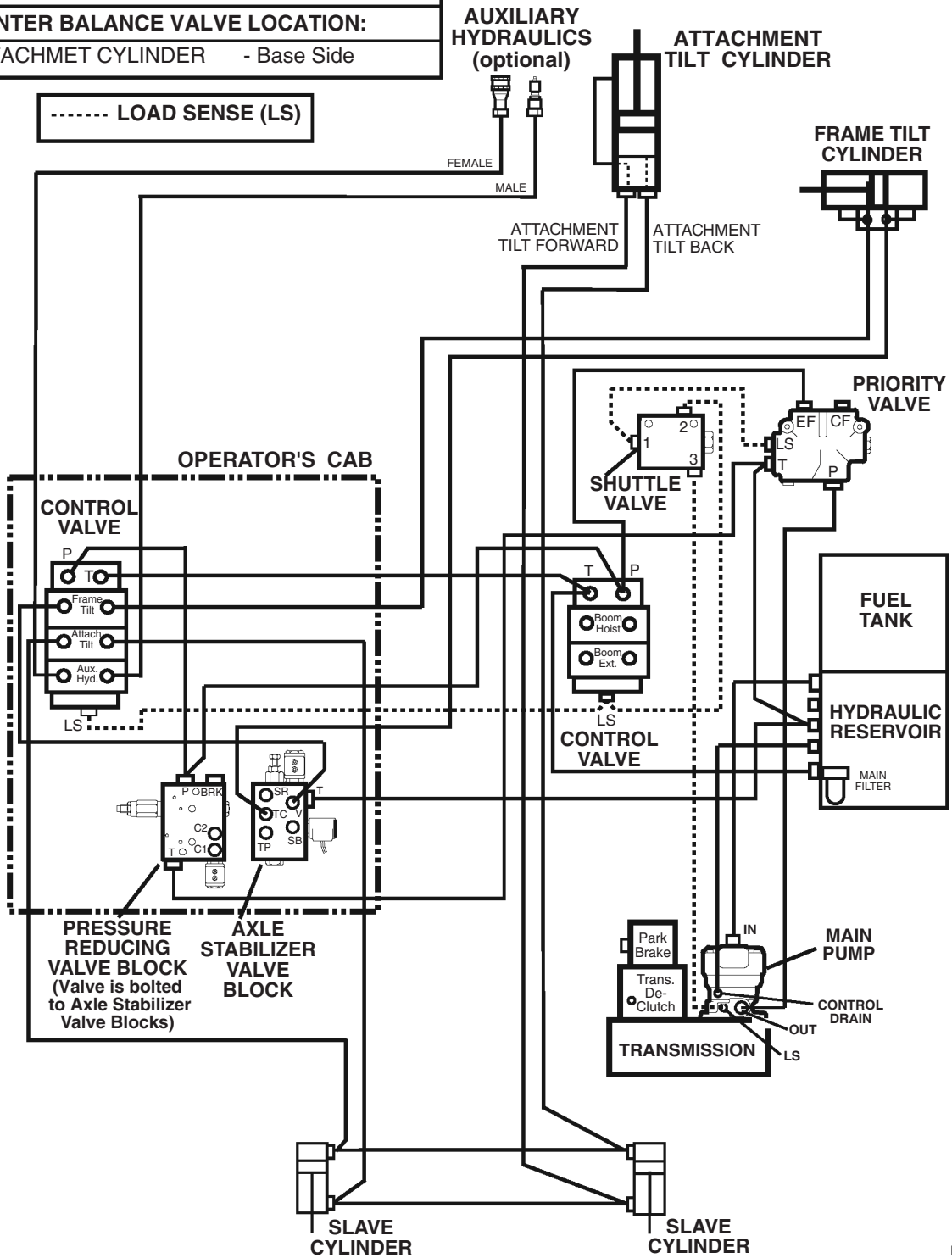

MH0750

8042/10042/10054 Frame Tilt, Attachment Tilt, Slave & Auxiliary Schematic (S/N 2194 & Before)

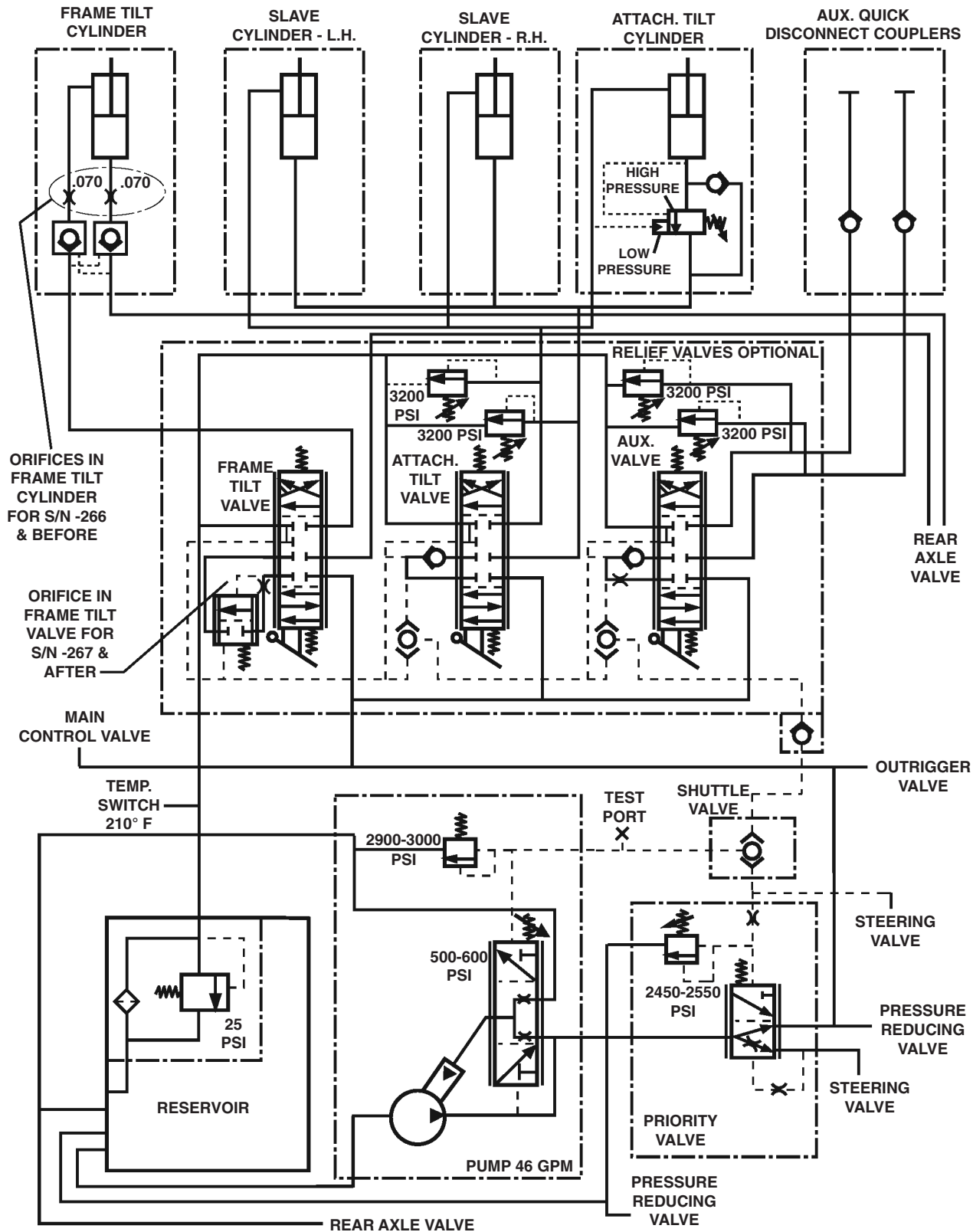

MH0321

8042/10042/10054 Frame Tilt, Attachment Tilt, Slave & Auxiliary Circuits (S/N 2195 thru 9908)

PILOT OPERATED CHECK VALVE LOCATIONS:	
FRAME TILT CYLINDER	- Rod & Base Sides
ATTACHMENT CYLINDER	- Base Side
COUNTER BALANCE VALVE LOCATION:	
ATTACHMET CYLINDER	- Base Side

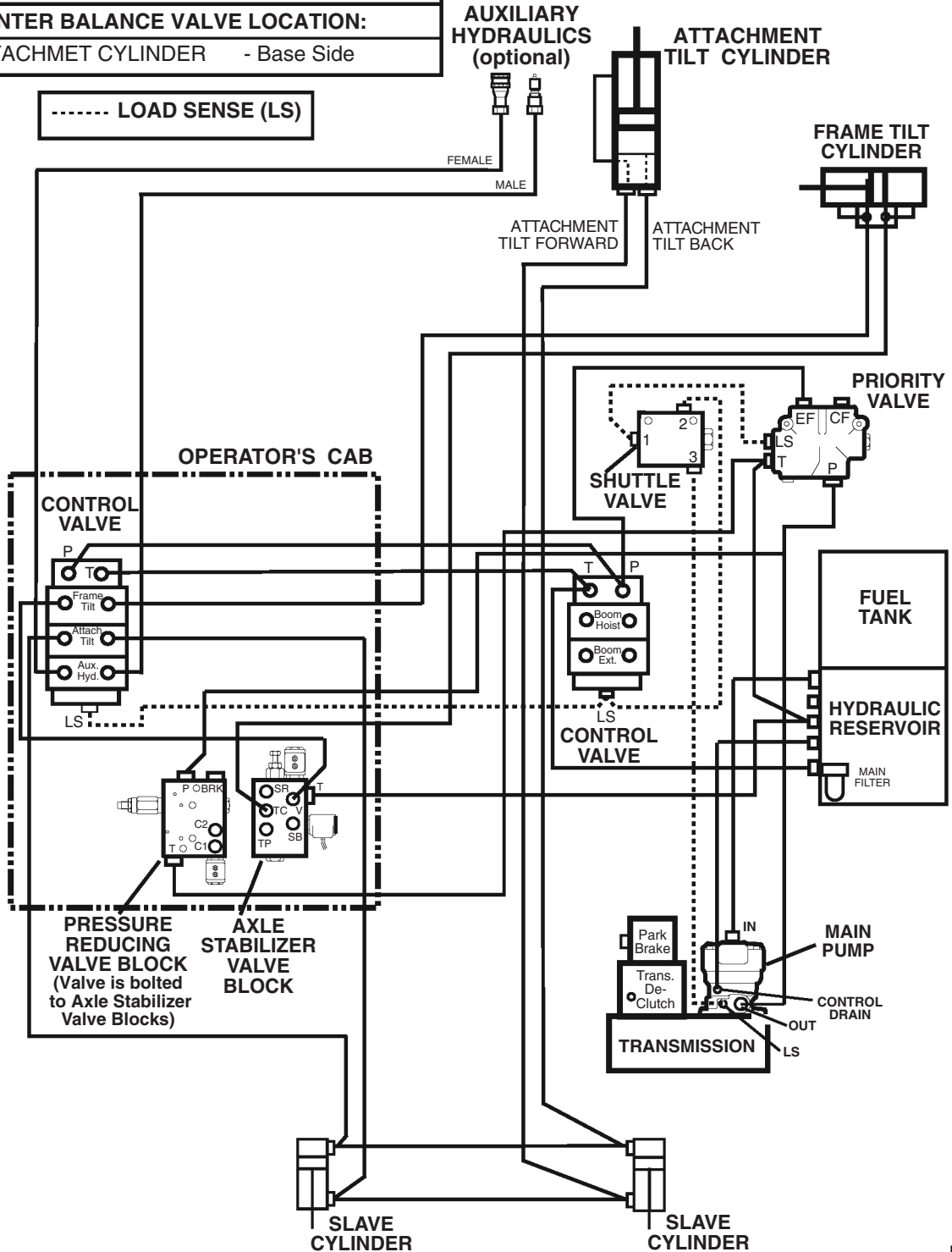

MH0760

8042/10042/10054 Frame Tilt, Attachment Tilt, Slave & Auxiliary Schematic (S/N 2195 thru 9908)

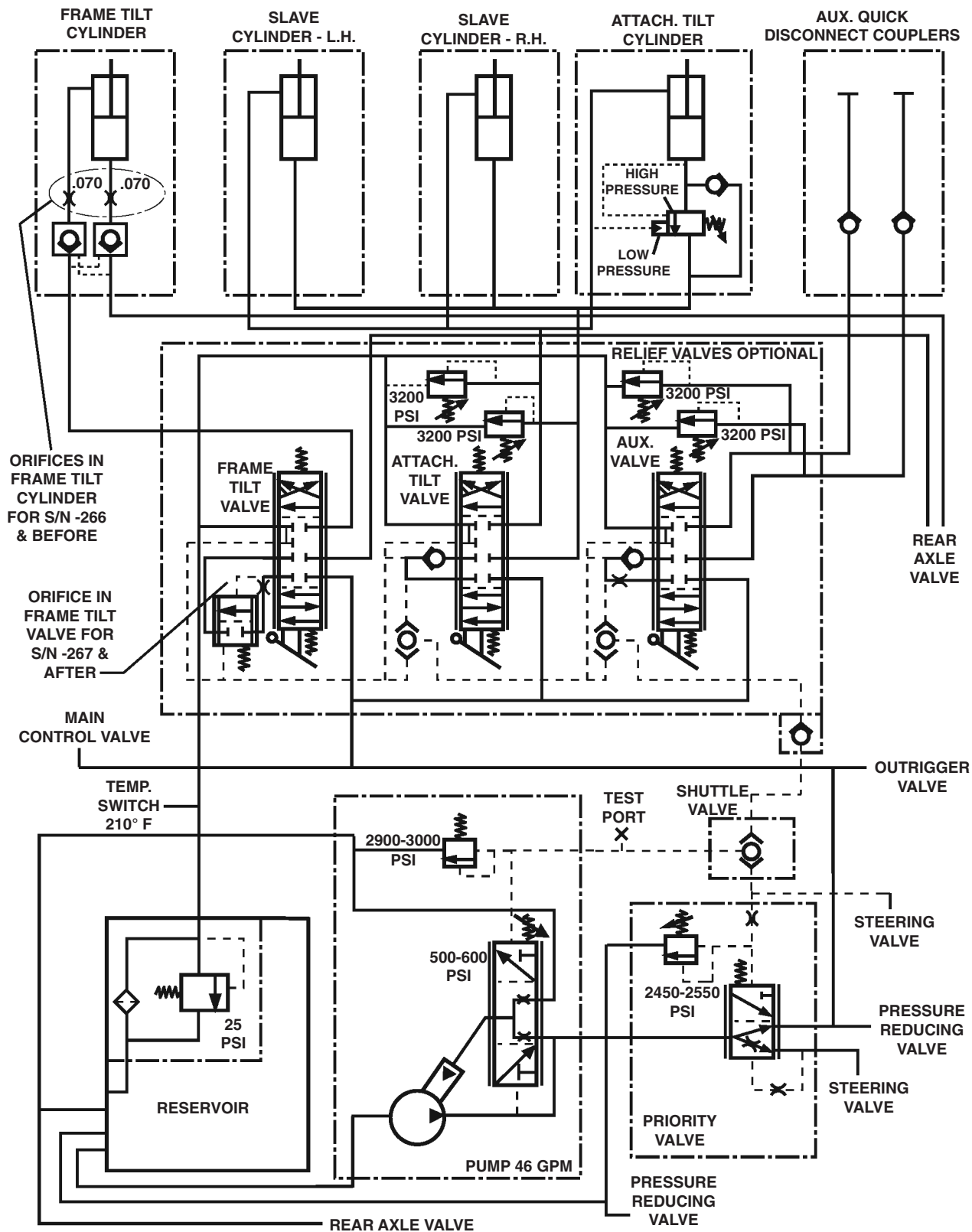

MH0321

8042/10042/10054 Frame Tilt, Attachment Tilt, Slave & Auxiliary Circuits (S/N 9909 & After)

PILOT OPERATED CHECK VALVE LOCATIONS:	
FRAME TILT CYLINDER	- Rod & Base Sides
ATTACHMENT CYLINDER	- Base Side
COUNTER BALANCE VALVE LOCATION:	
ATTACHMET CYLINDER	- Base Side

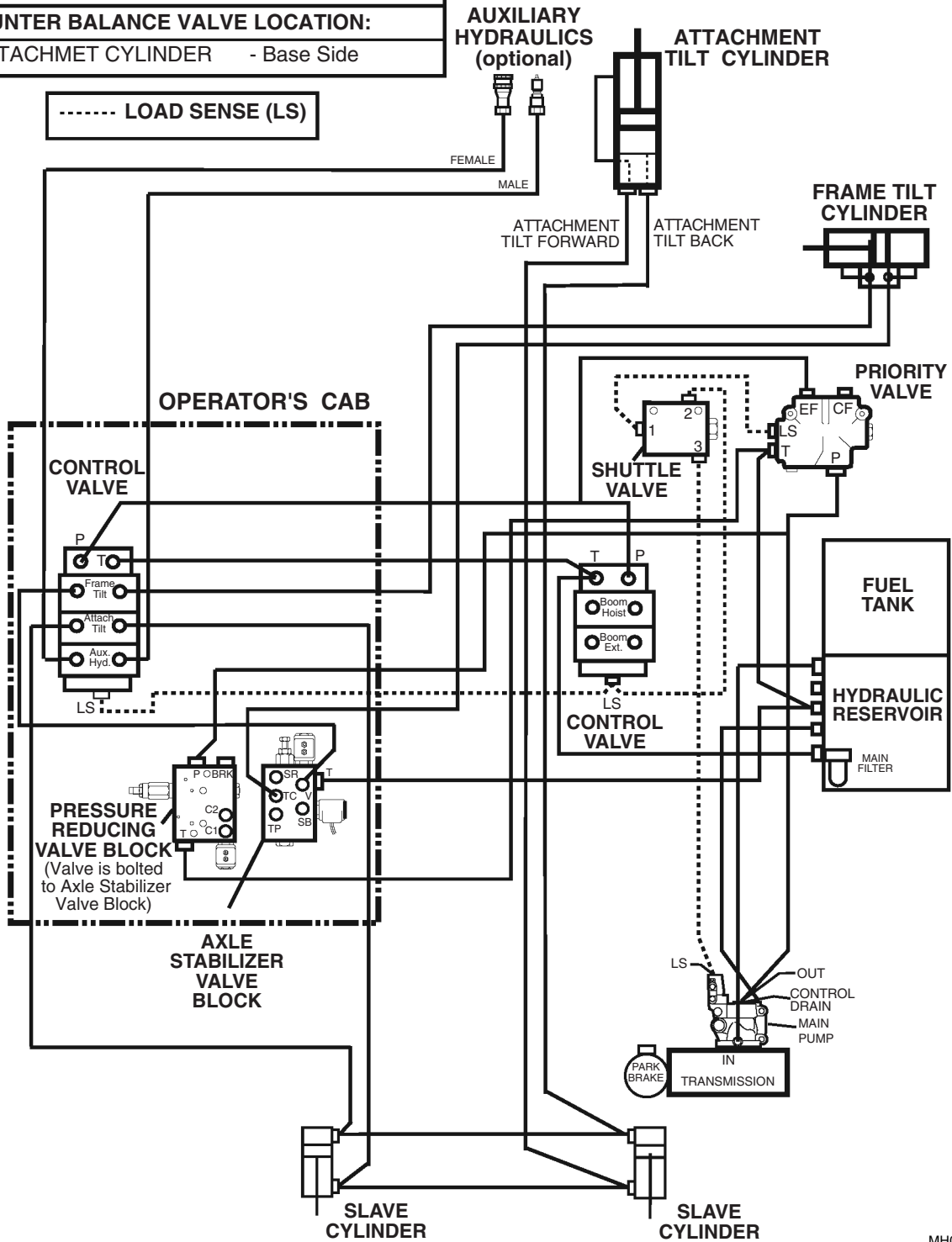

MH0740

8042/10042/10054 Frame Tilt, Attachment Tilt, Slave & Auxiliary Schematic (S/N 9909 & After)

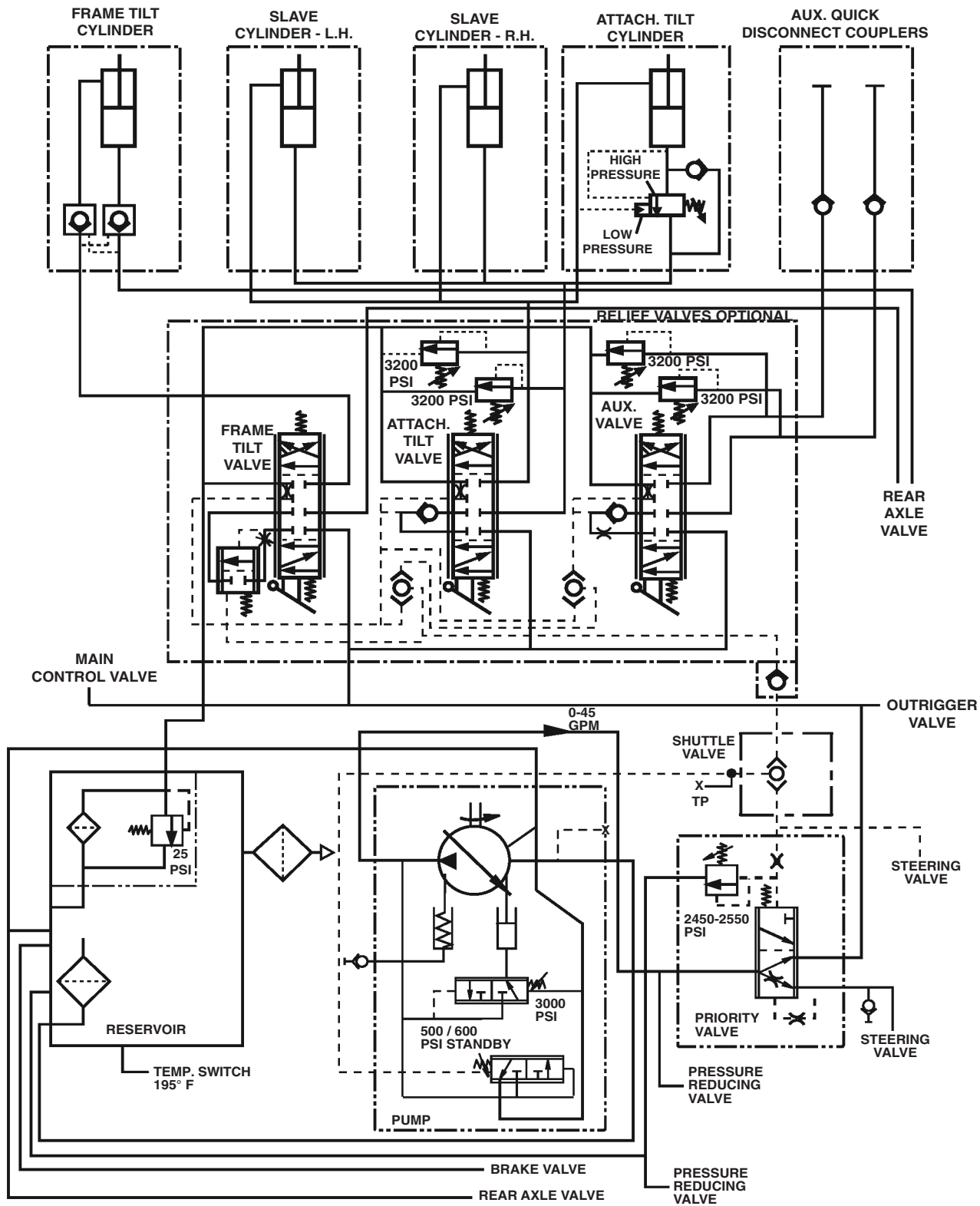

MH0640

8042/10042/10054 Steering Circuit (S/N 9908 & Before)

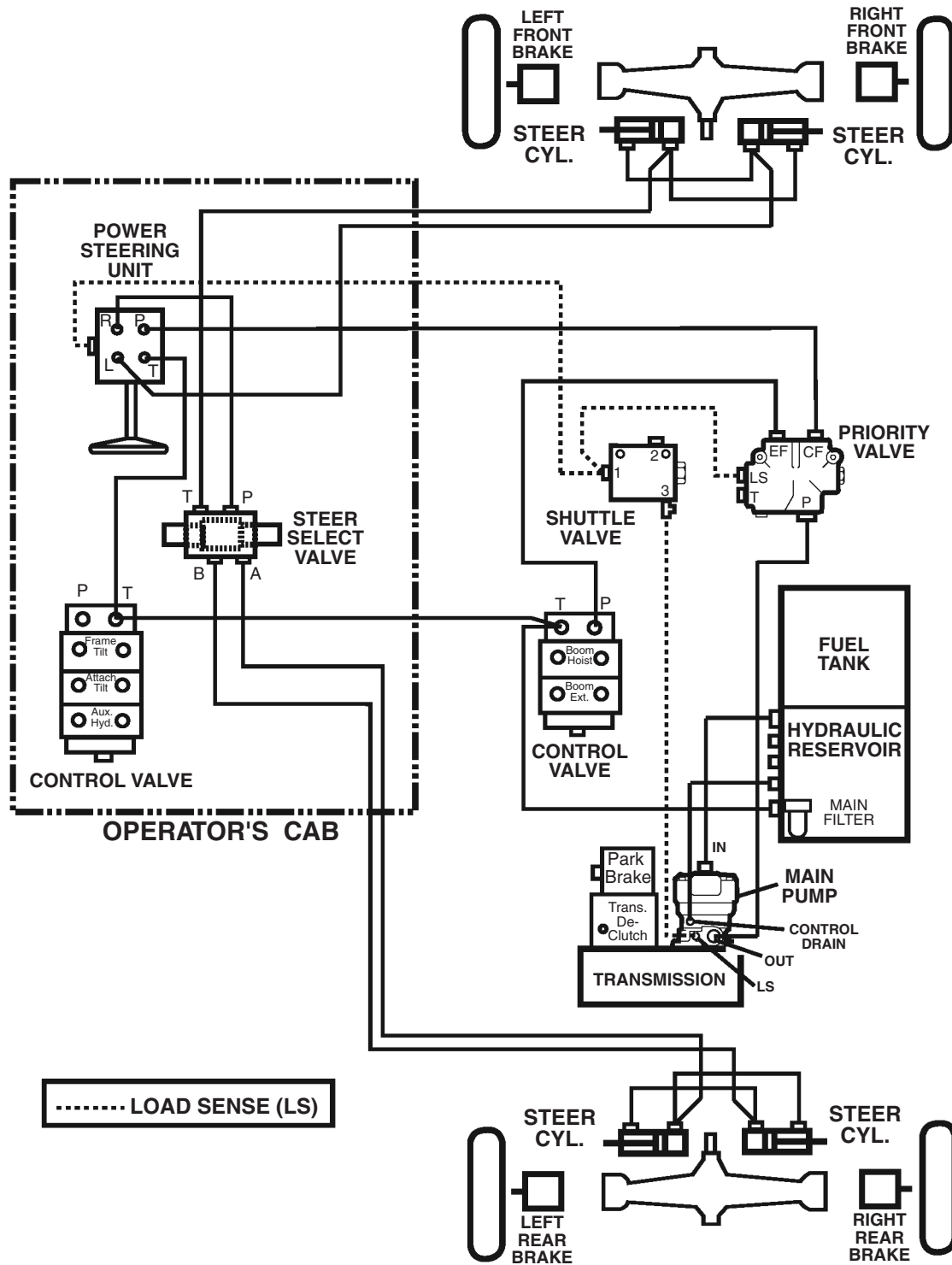

MH0132

8042/10042/10054 Steering Schematic (S/N 9908 & Before)

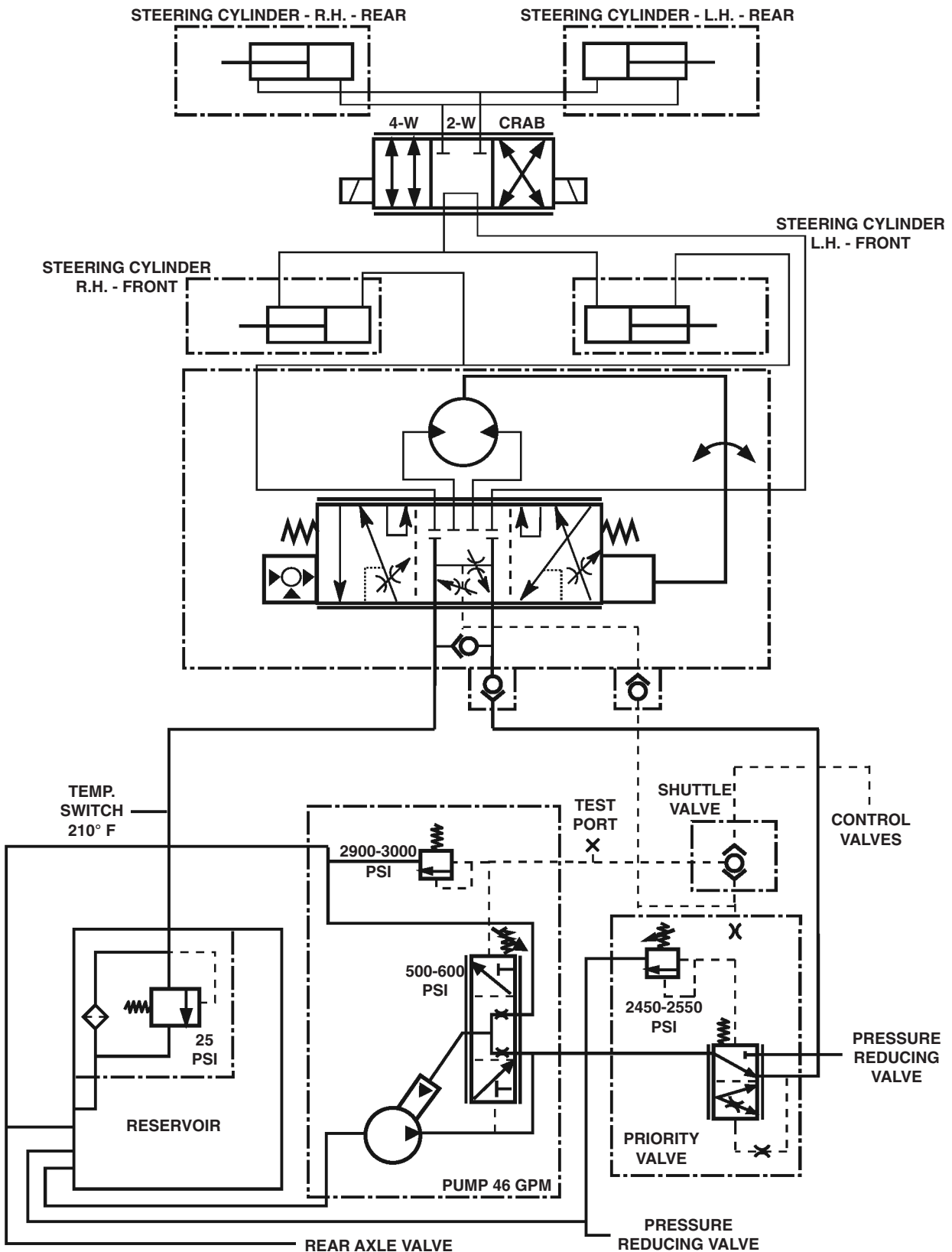

MH0331

8042/10042/10054 Steering Circuit (S/N 9909 & After)

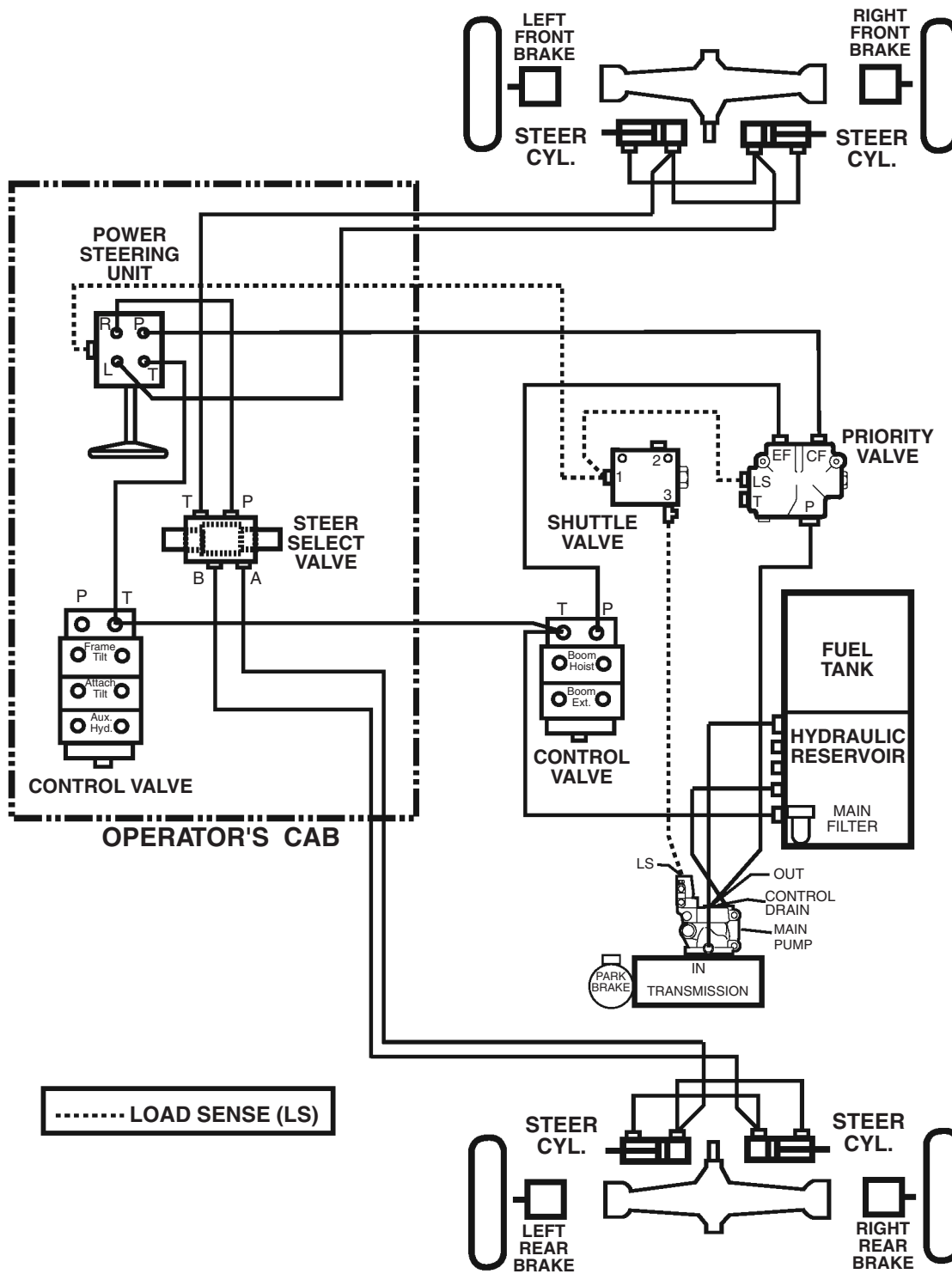

MH0600

8042/10042/10054 Steering Schematic (S/N 9909 & After)

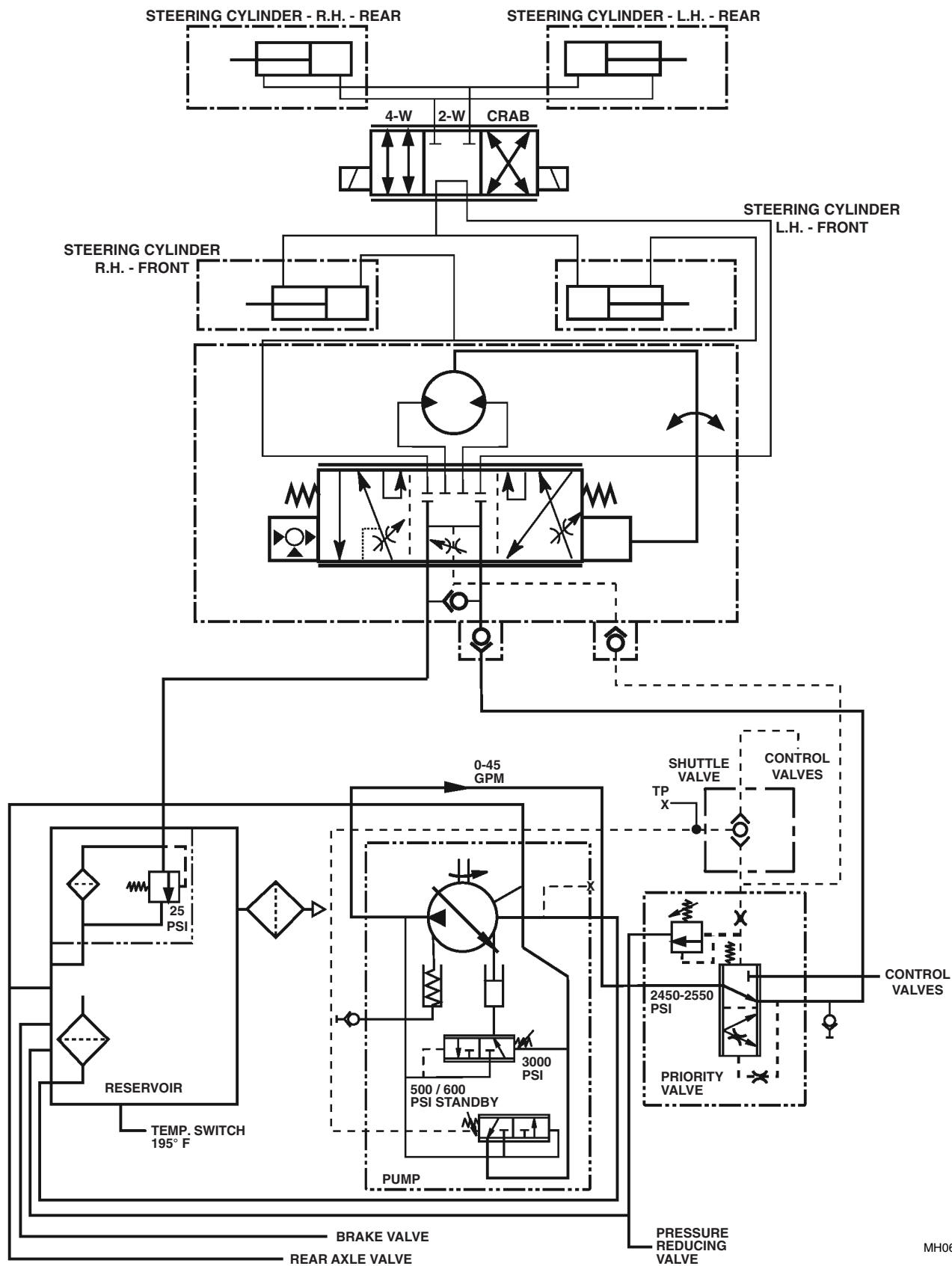

MH0650

8042/10042/10054 Service Brake & De-Clutch Circuits (S/N 9908 & Before)

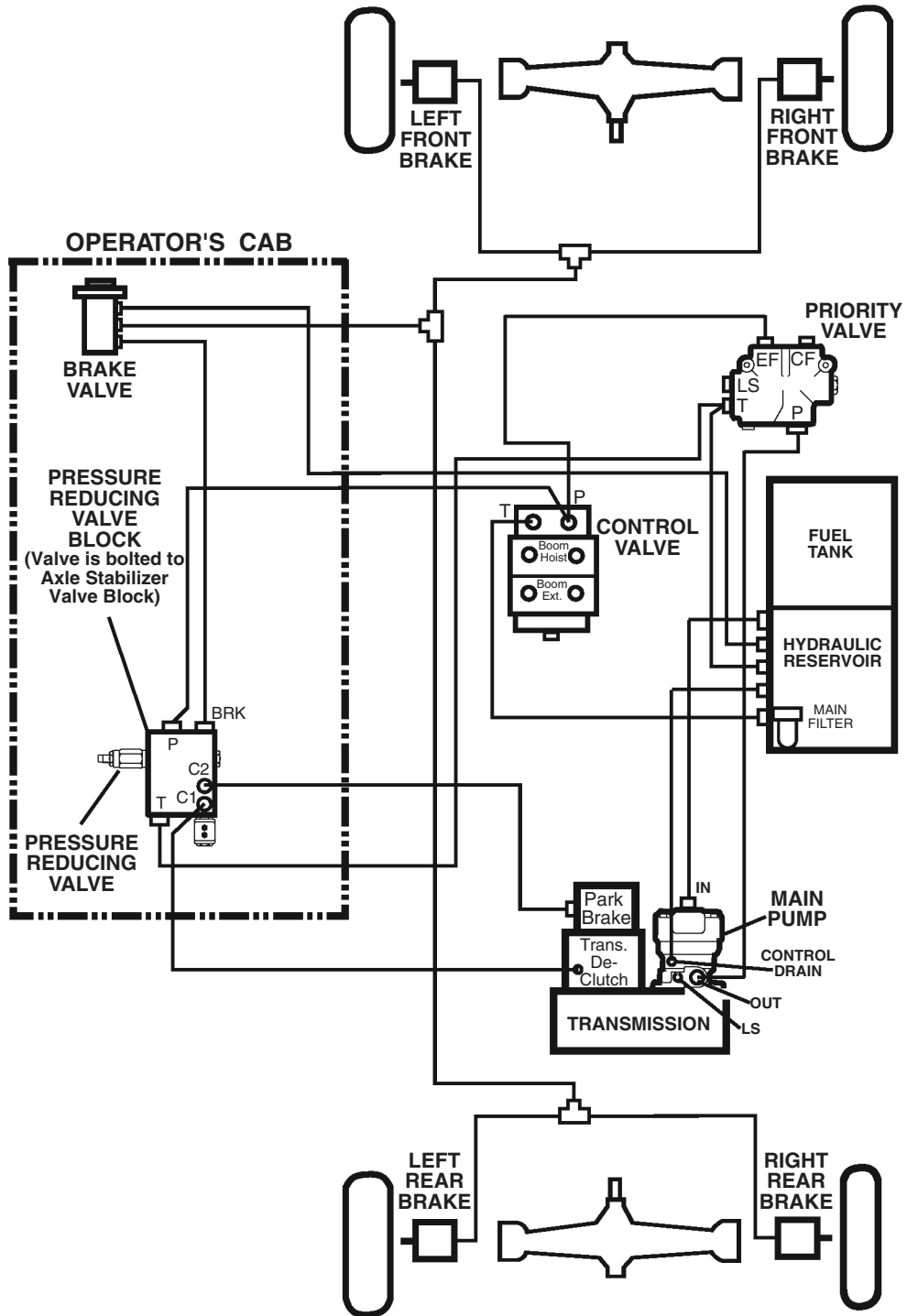

MH0141

8042/10042/10054 Service Brake & De-Clutch Schematic (S/N 9908 & Before)

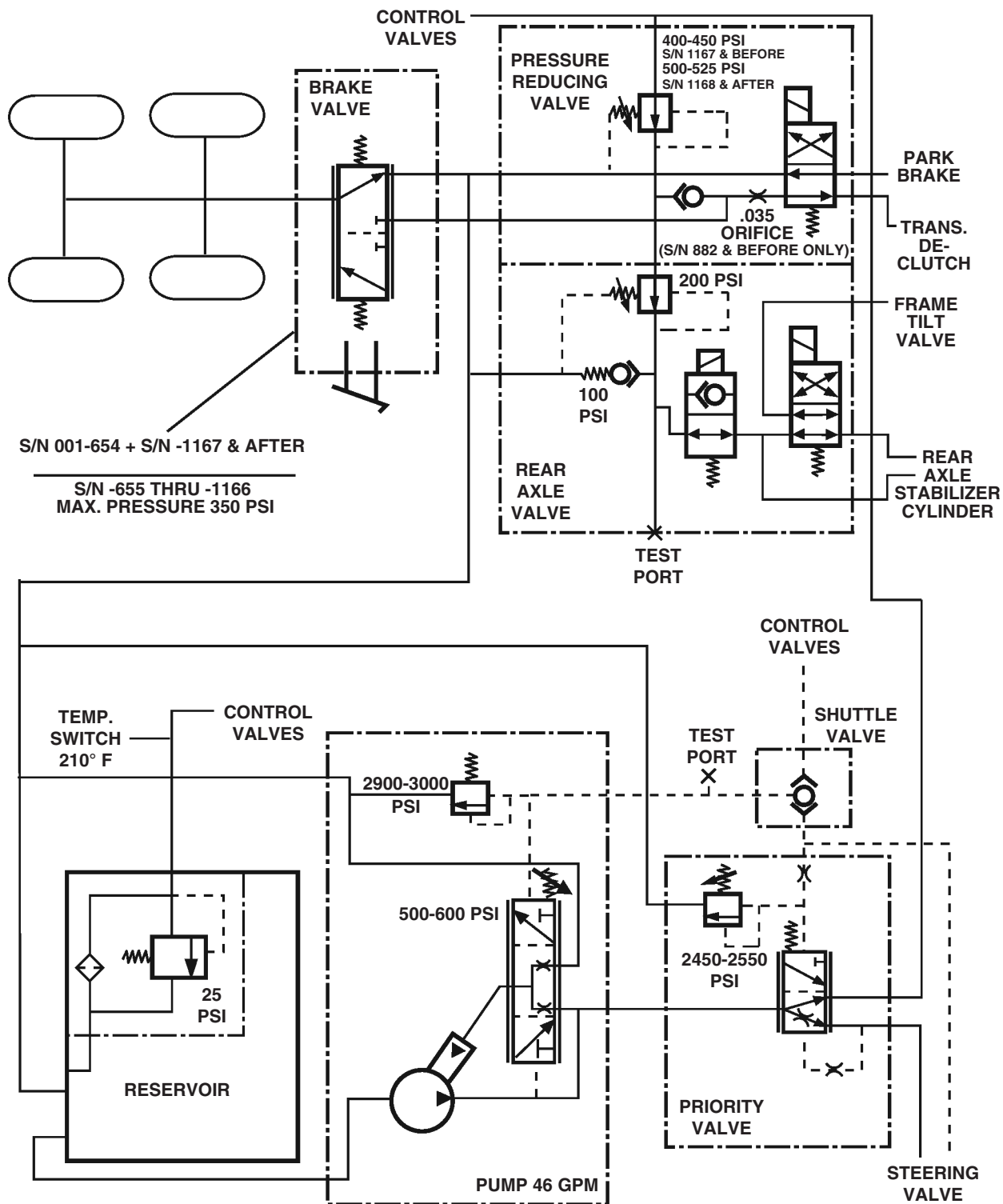

MH0341

8042/10042/10054 Service Brake Circuit (S/N 9909 & After)

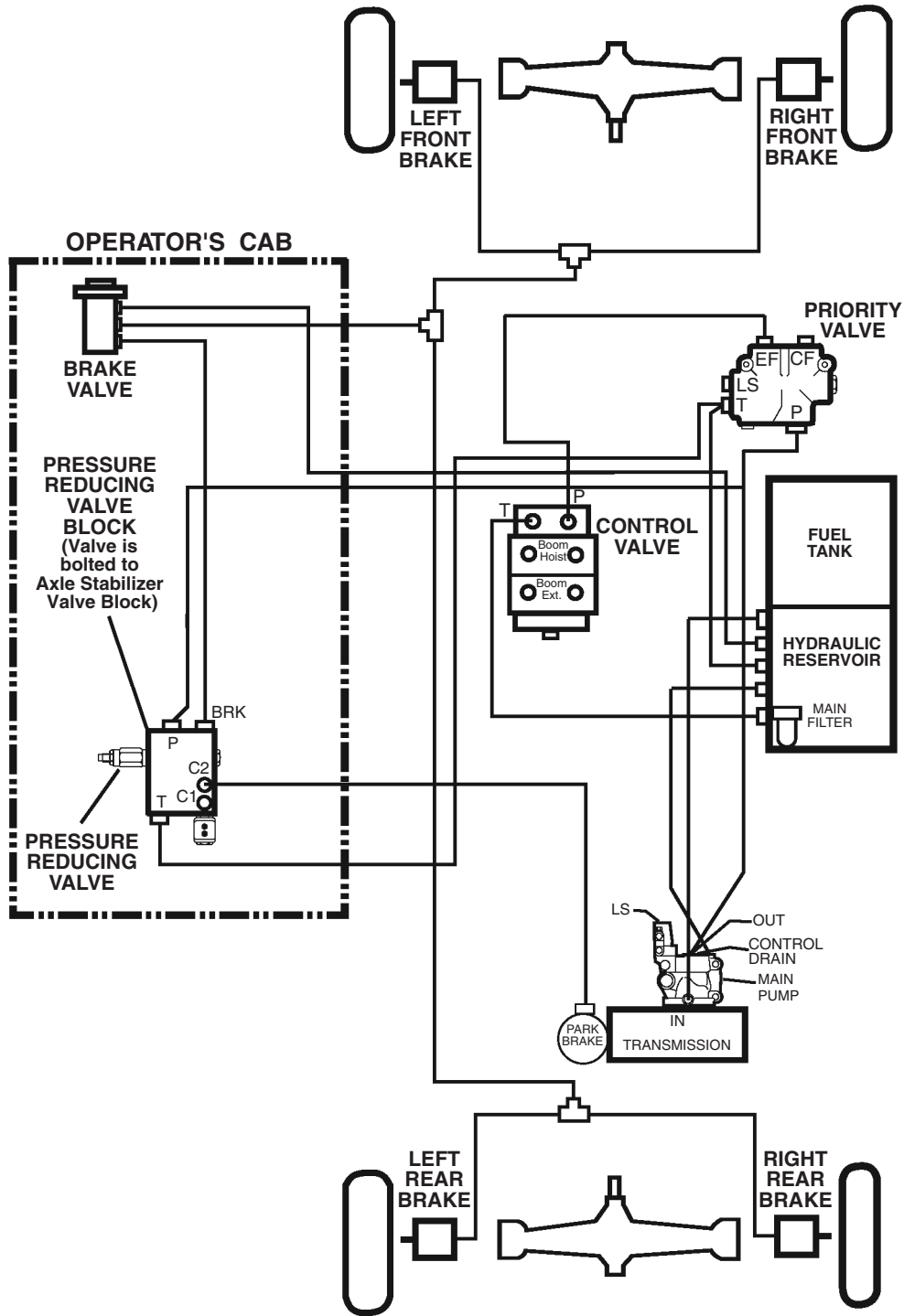

MH0610

8042/10042/10054 Service Brake Schematic (S/N 9909 & After)

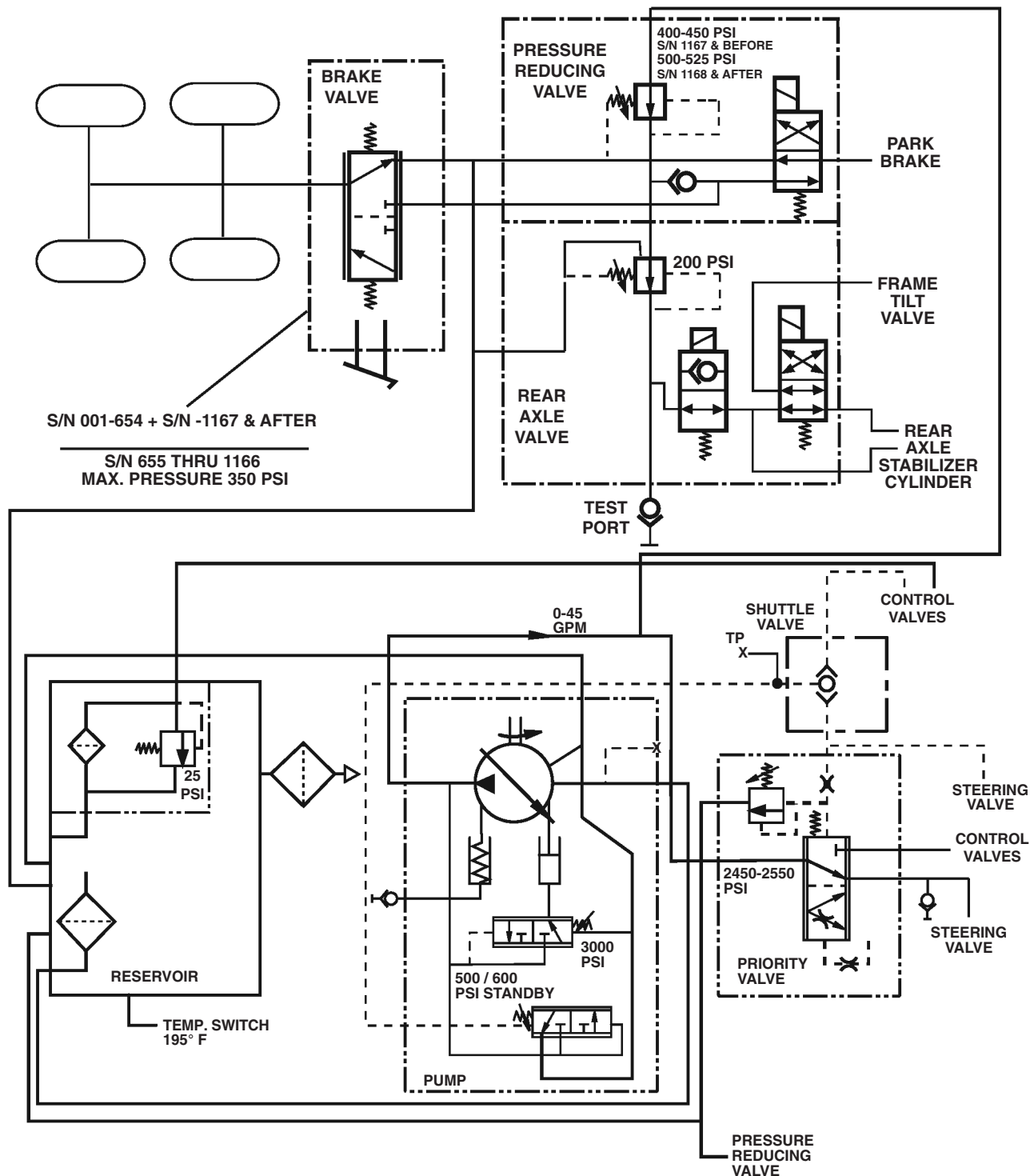

MH0660

10042/10054 Outrigger Schematic (S/N 10881 & Before)

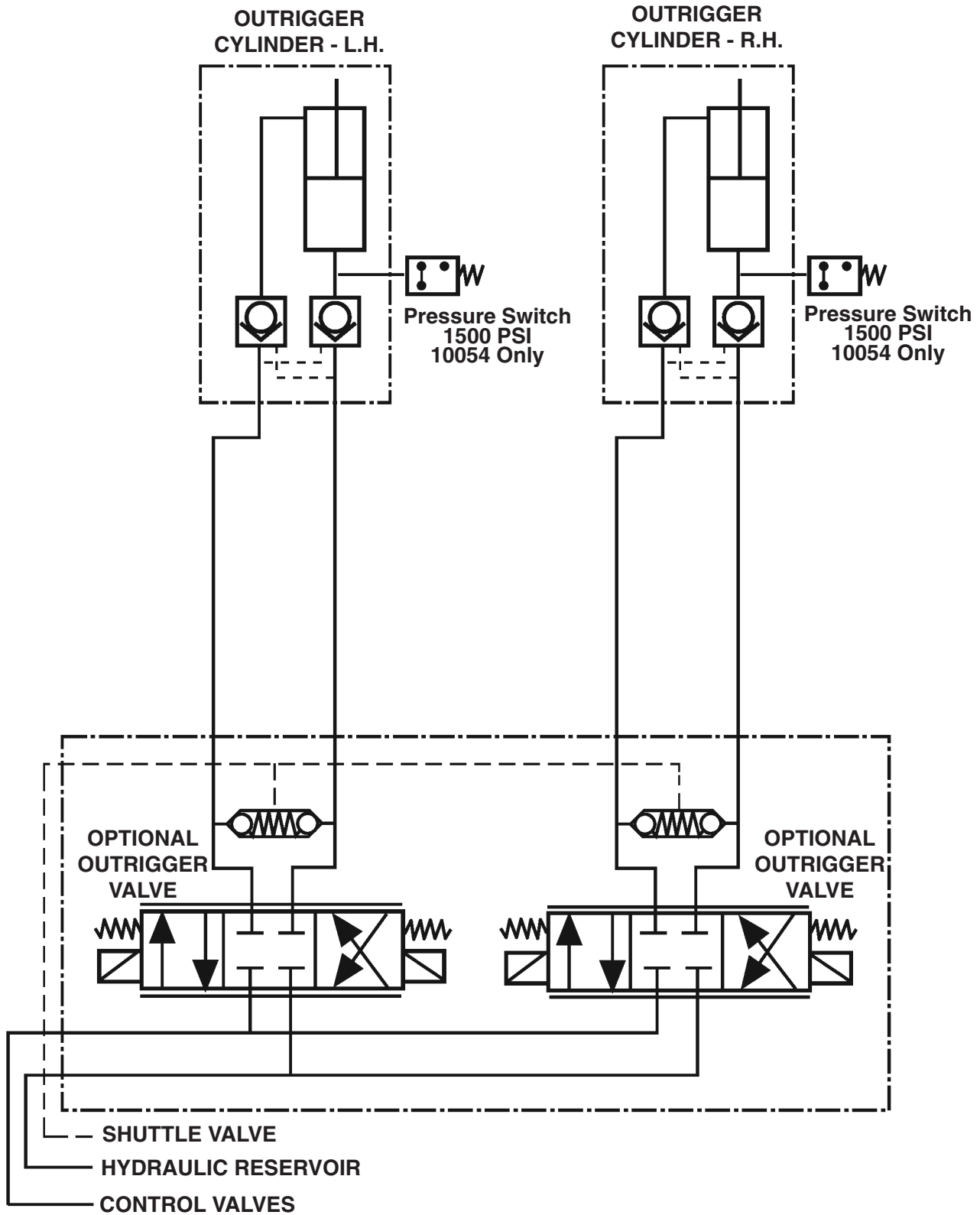

10042/10054 Outrigger Schematic (S/N 10882 & After)

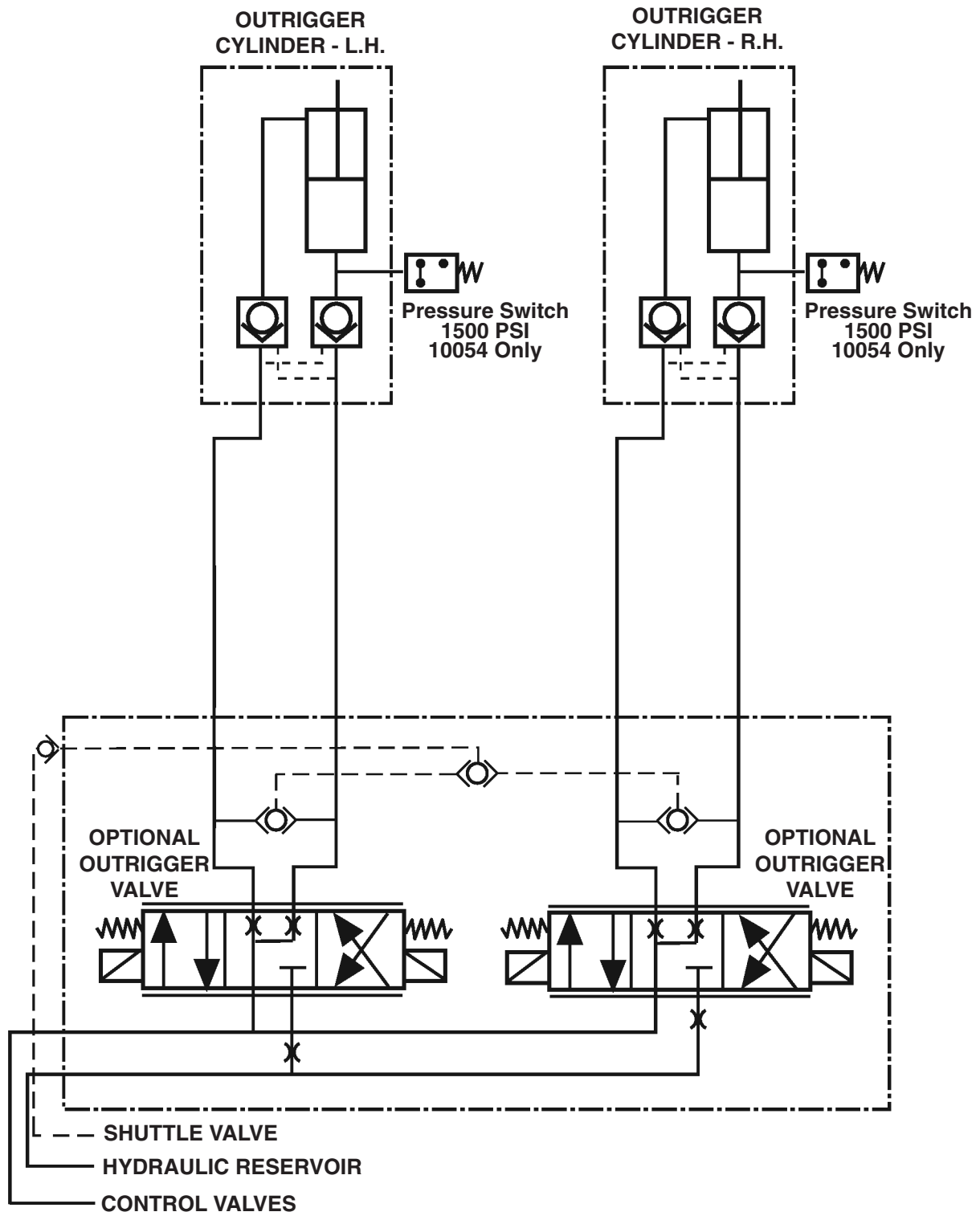

MH0670

8042/10042 Electrical Schematic (S/N 0292 thru 9908)

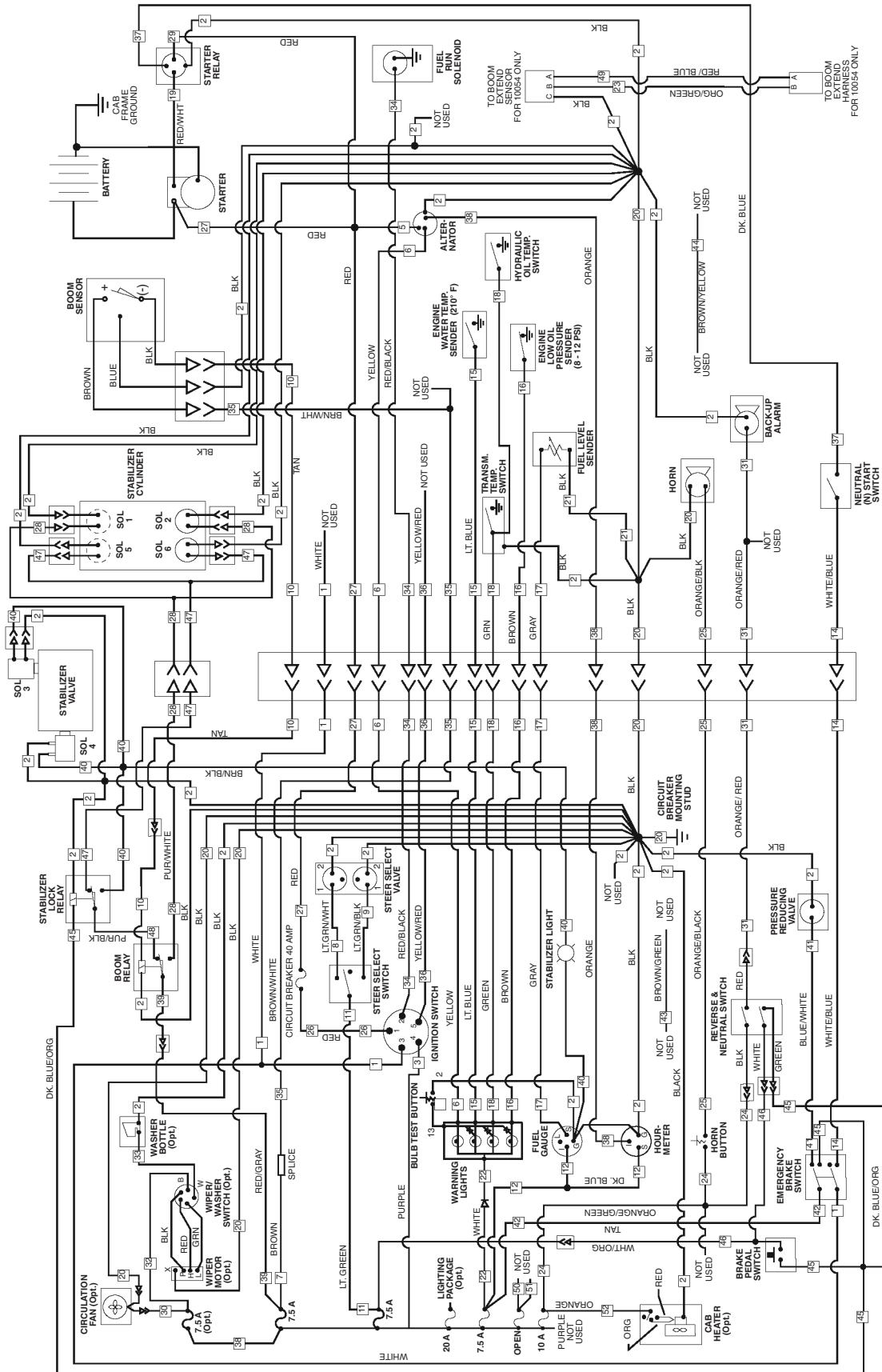

10054 Electrical Schematic (S/N 9908 & Before)

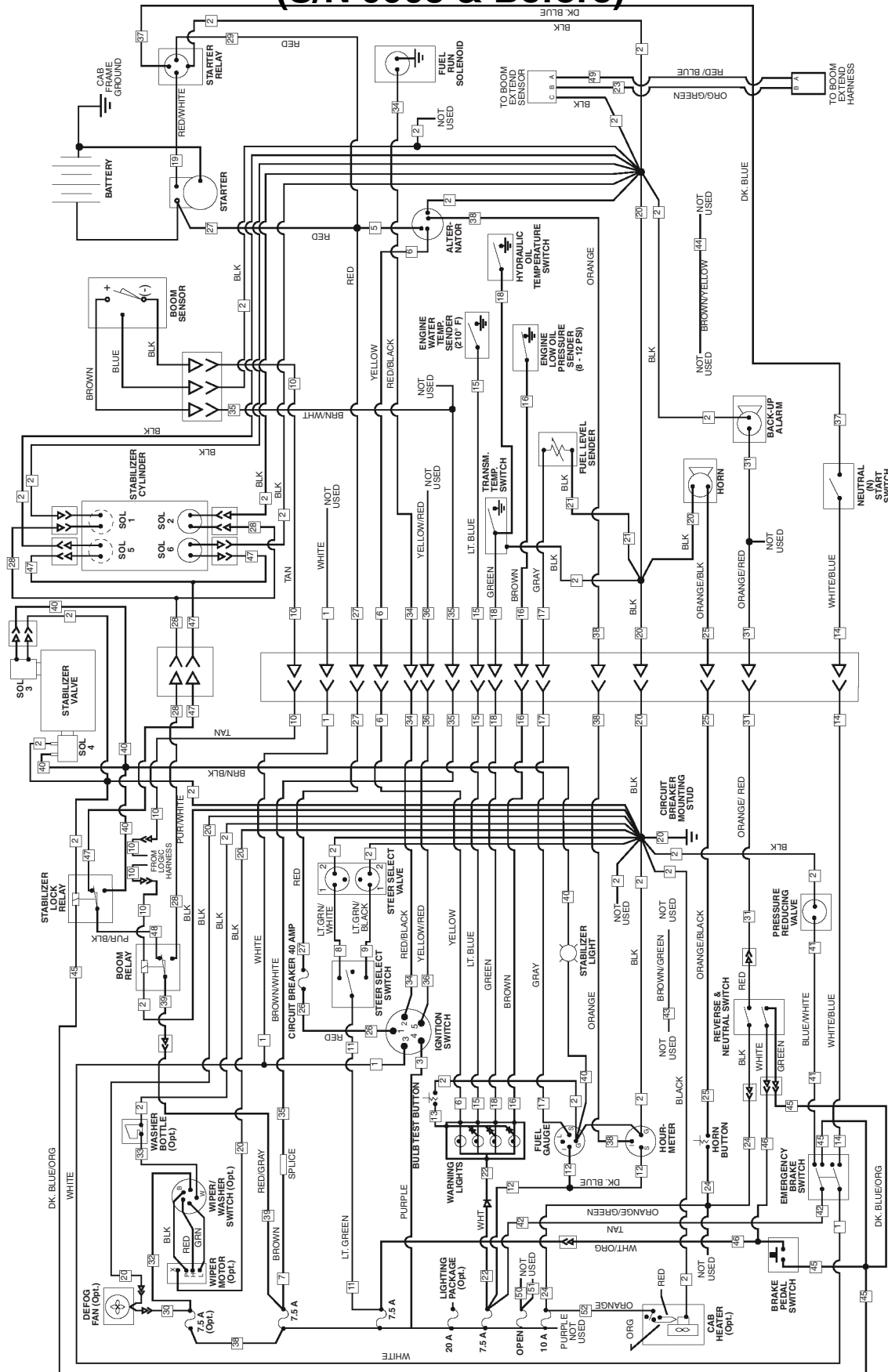

10042 Outrigger Logic Circuit

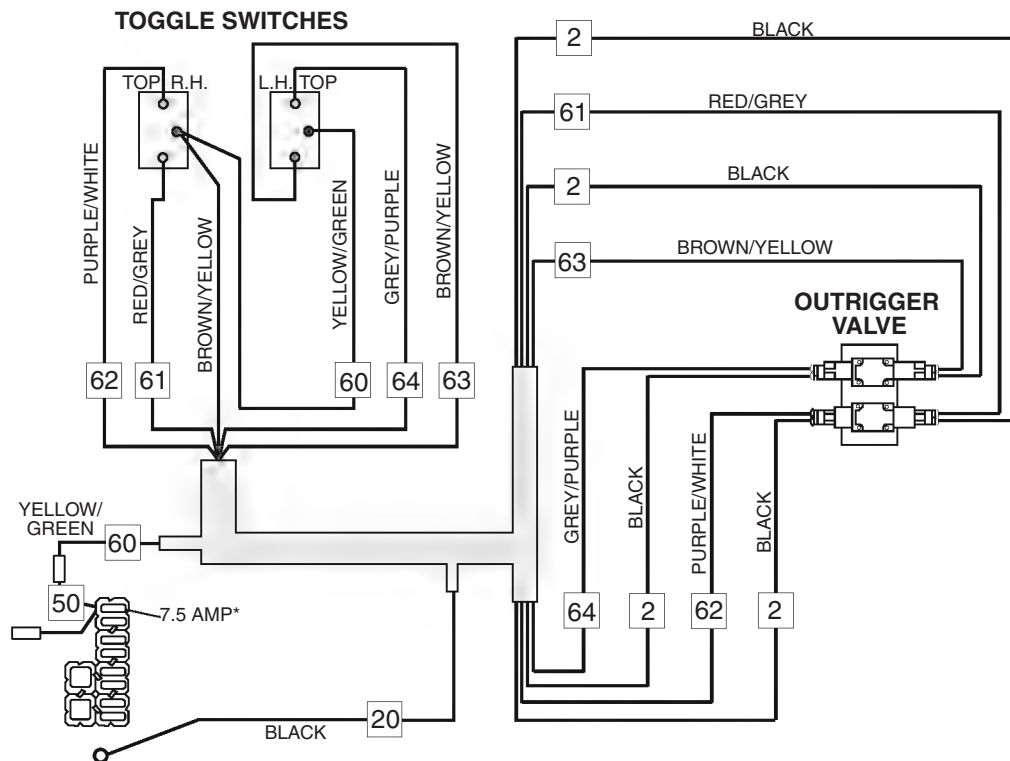

*7.5 AMP - S/N 0292 & After
 6.0 AMP - S/N 0291 & Before

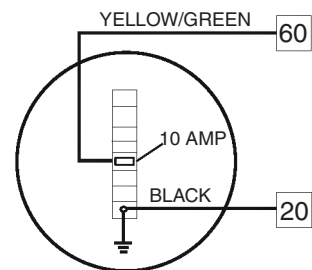

**FOR UNITS WITH
 CIRCUIT BREAKERS**

10054 Outrigger Logic Circuit (S/N 9909 & After)

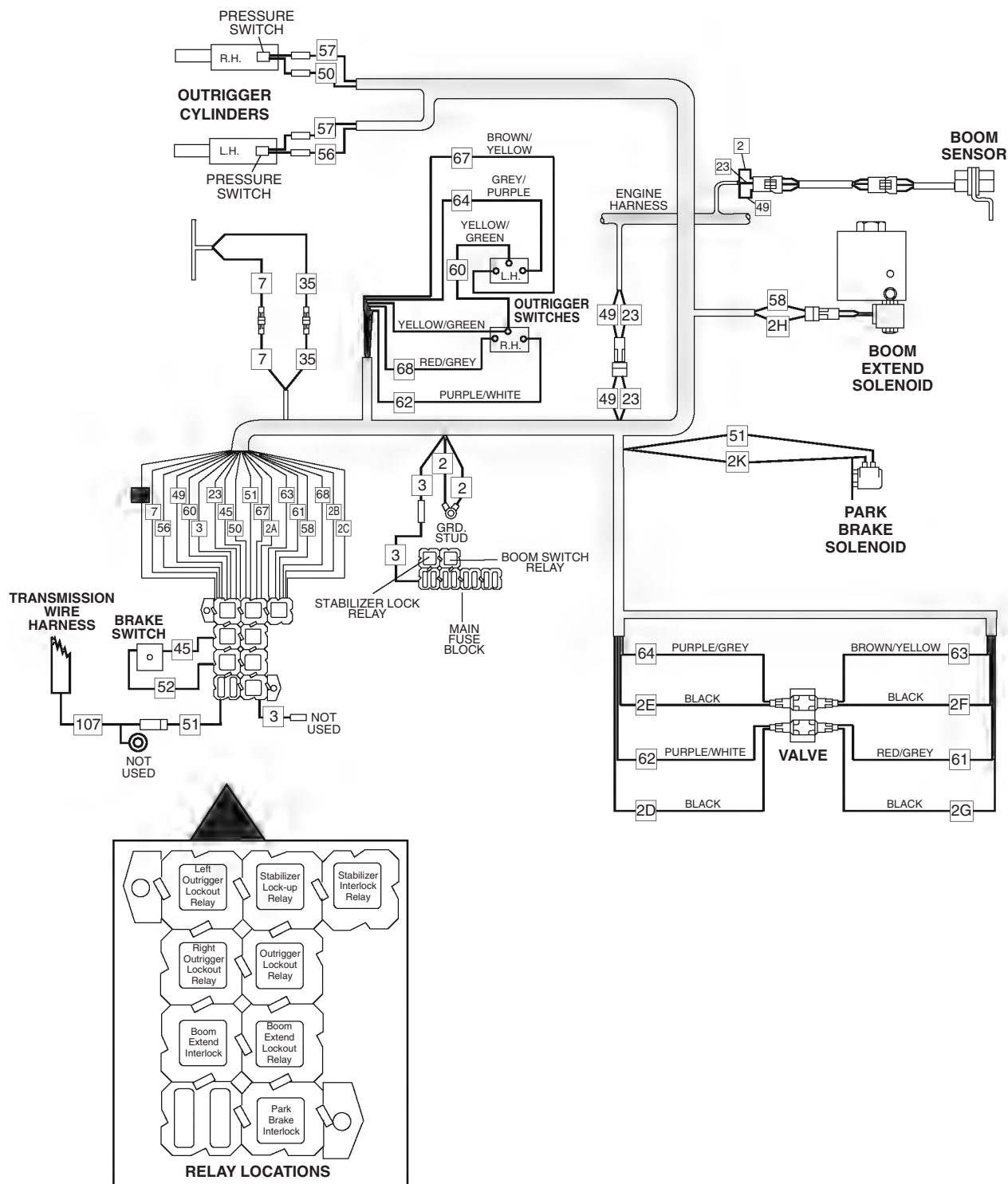

MH0710

8042/10042/10054 Lighting System Circuit (Optional)

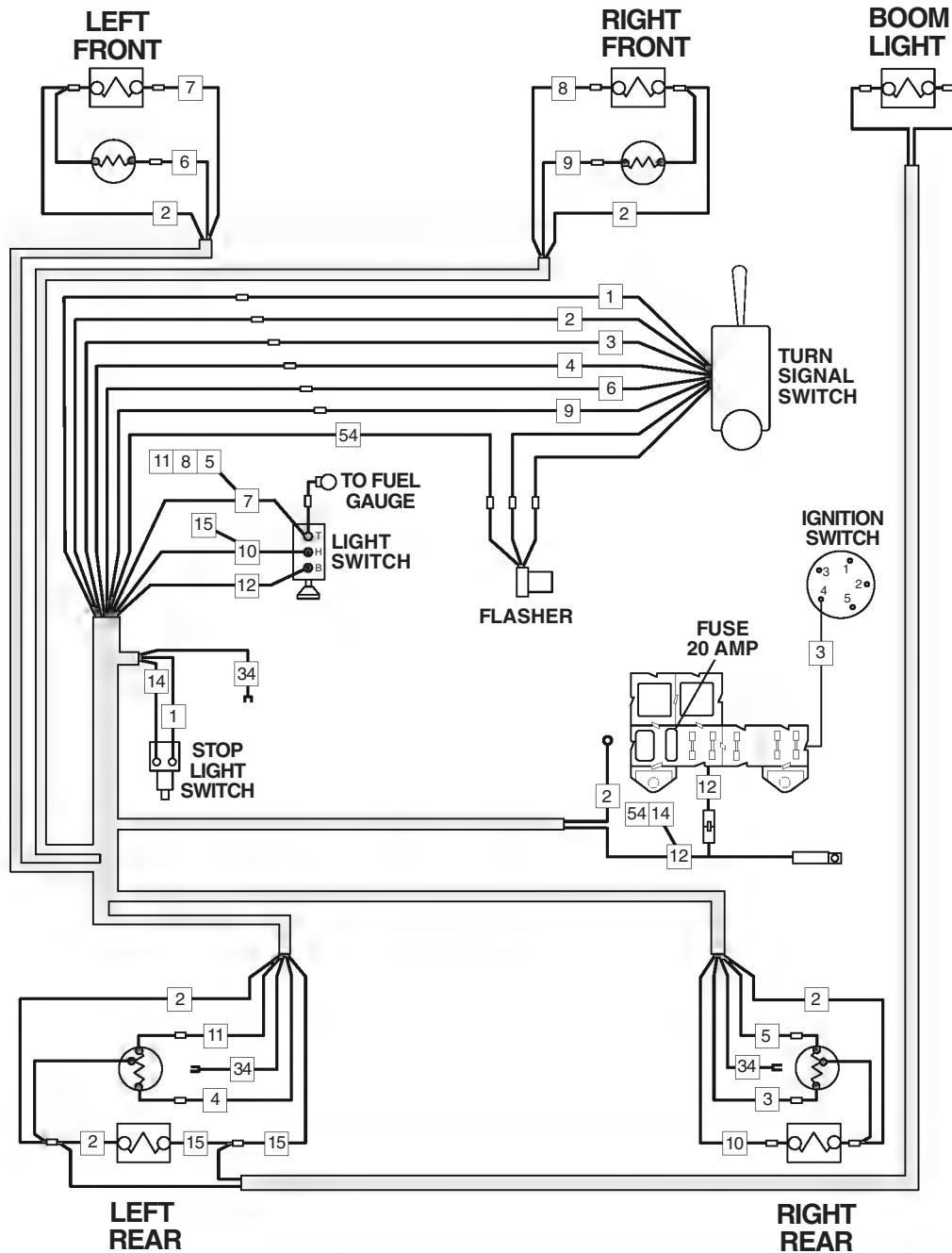

8042/10042/10054 Charging Circuit

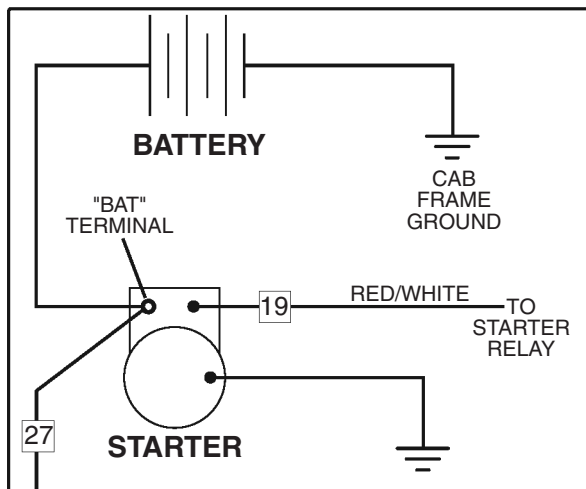

S/N 0292 & Before

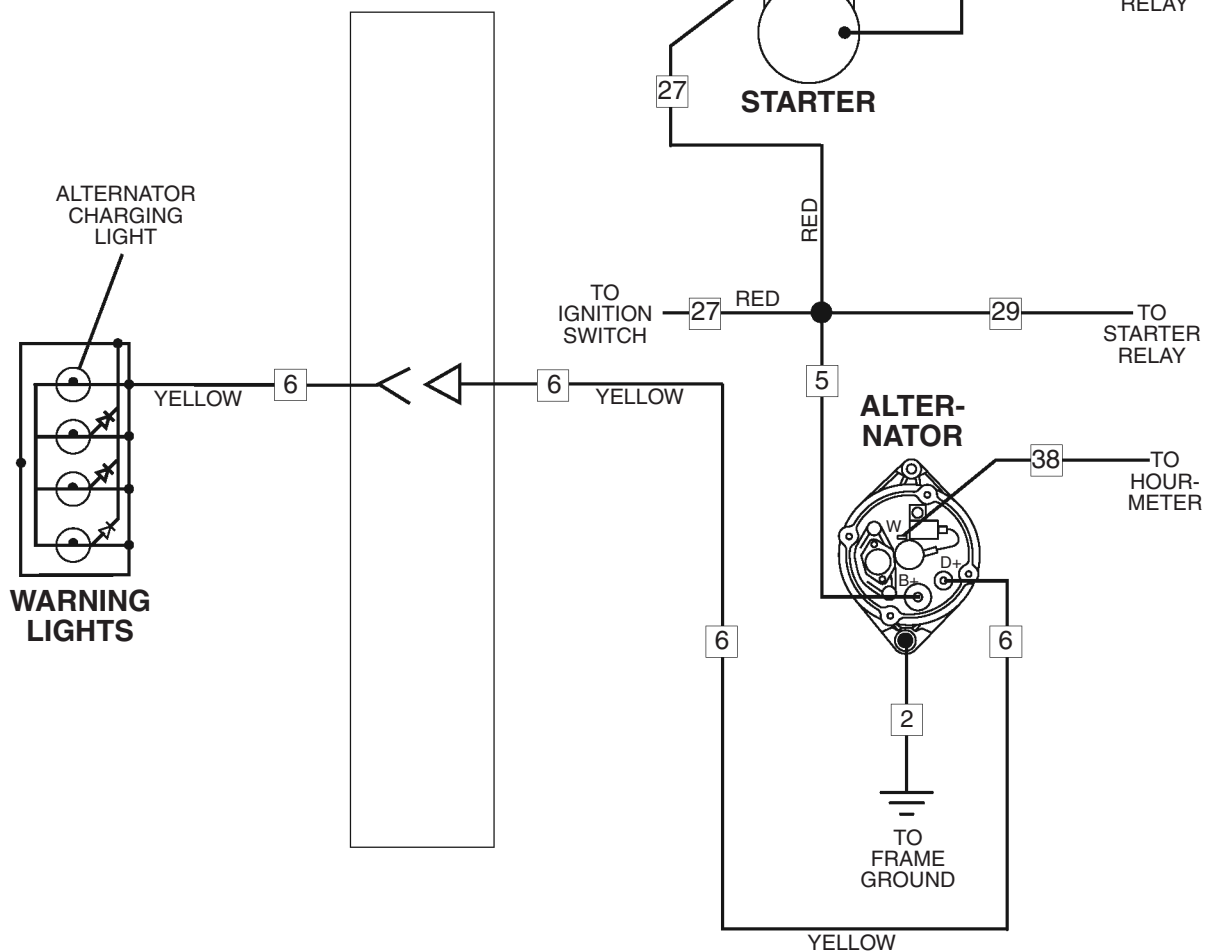
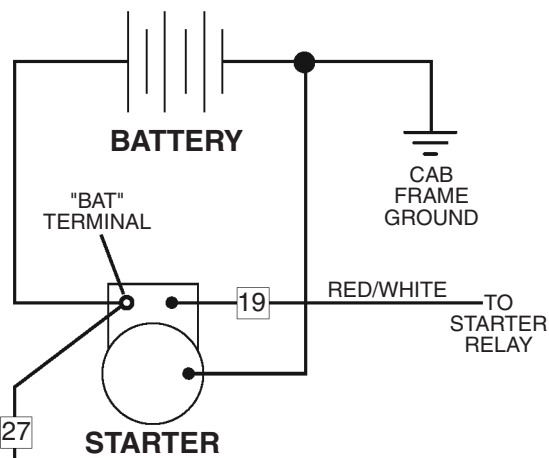

8042/10042/10054 Cranking Circuit (S/N 9908 & Before)

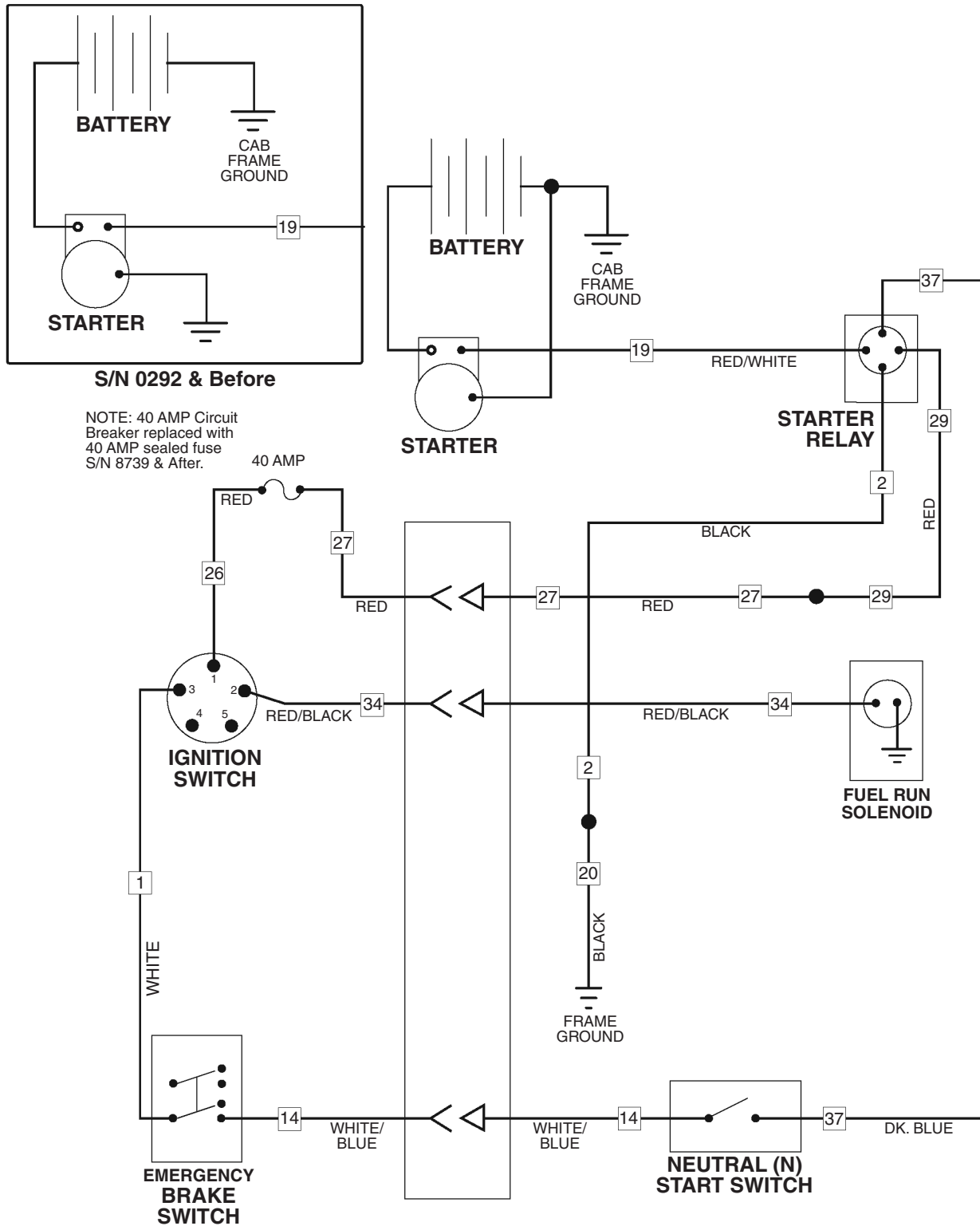

MH0221

8042/10042 Steer Select Circuit (S/N 0291 & Before)

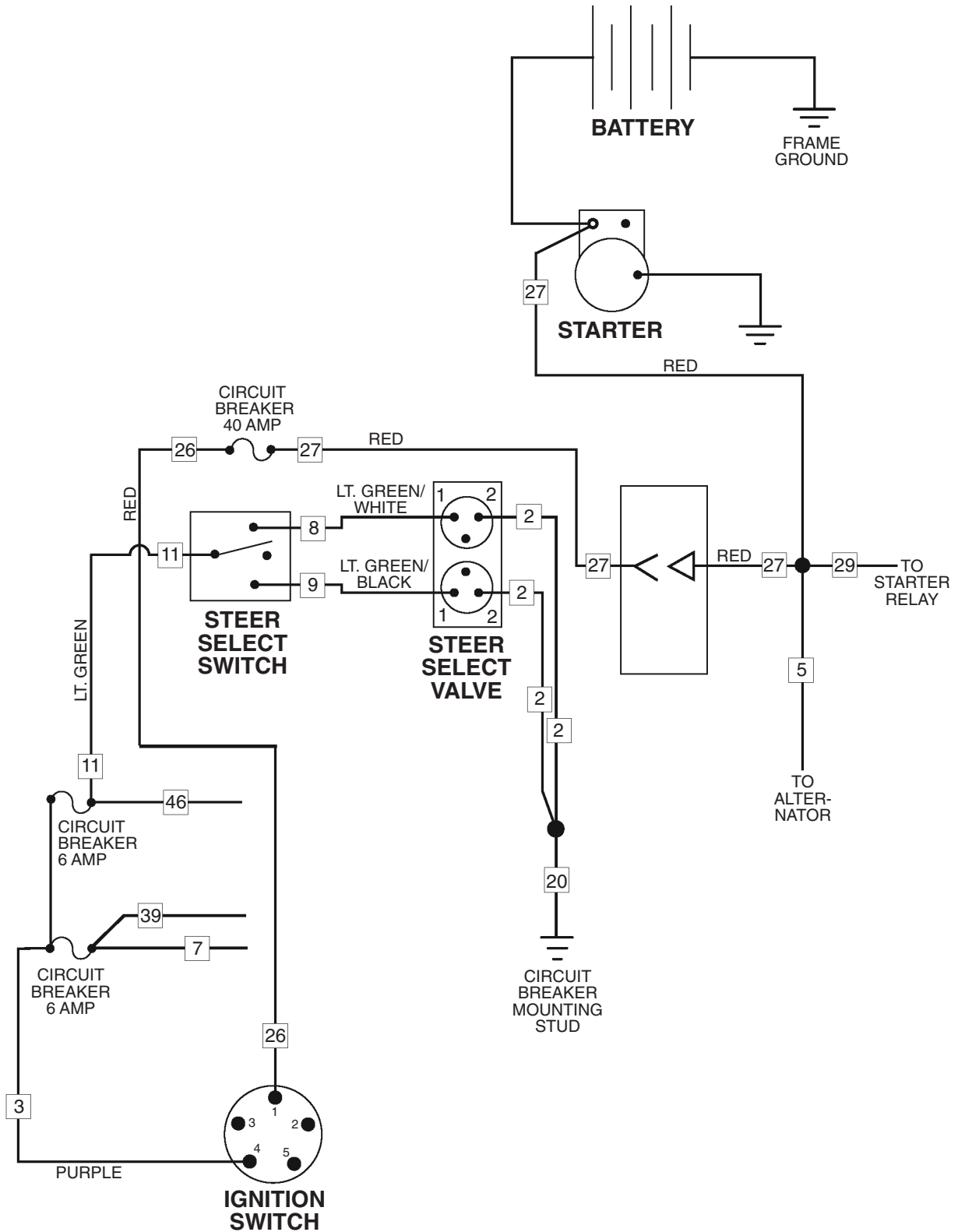

MH0231

8042/10042/10054 Steer Select Circuit (S/N 0292 & After)

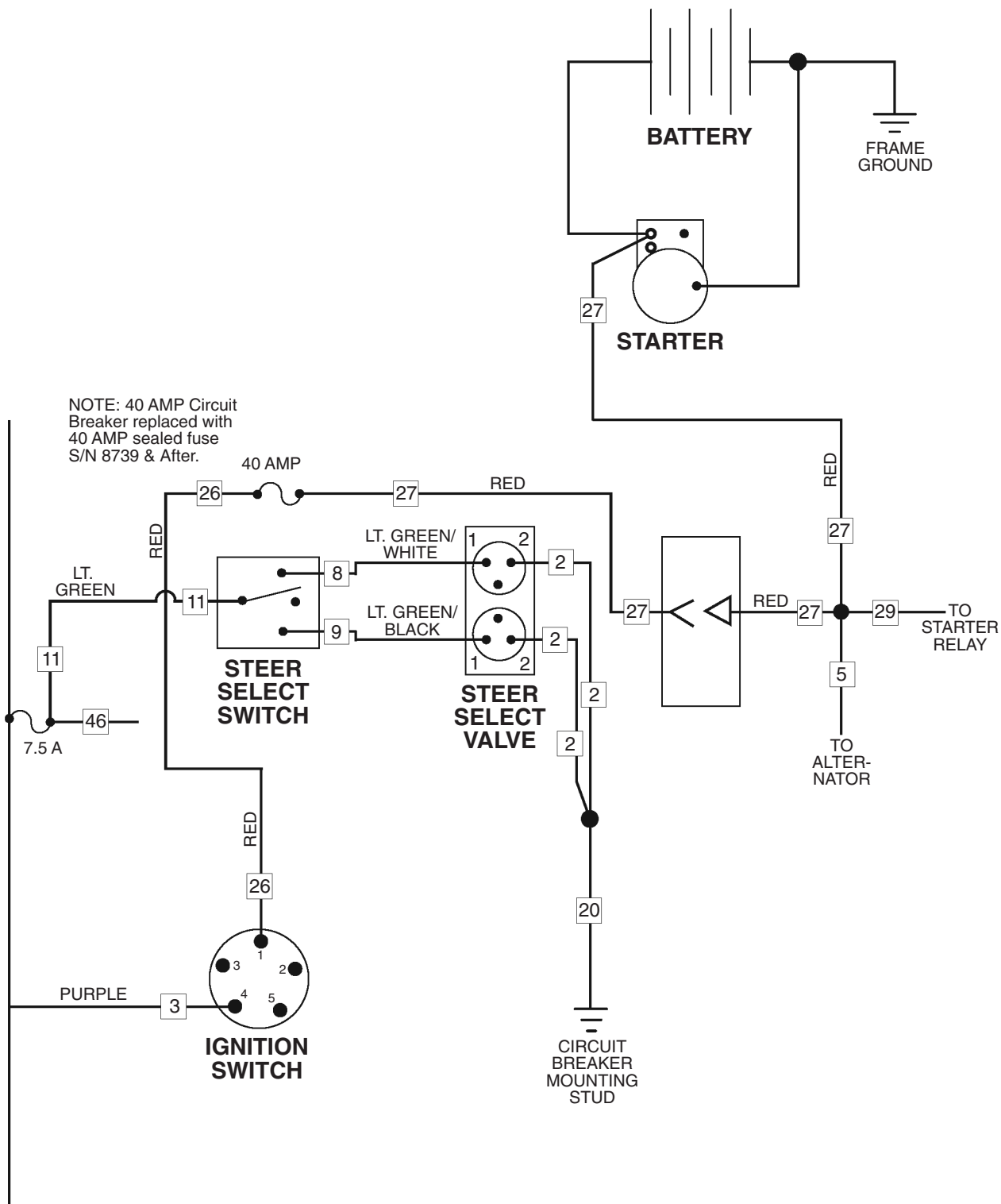

MH0241

8042/10042 Stabilizer Circuit (S/N 0291 & Before)

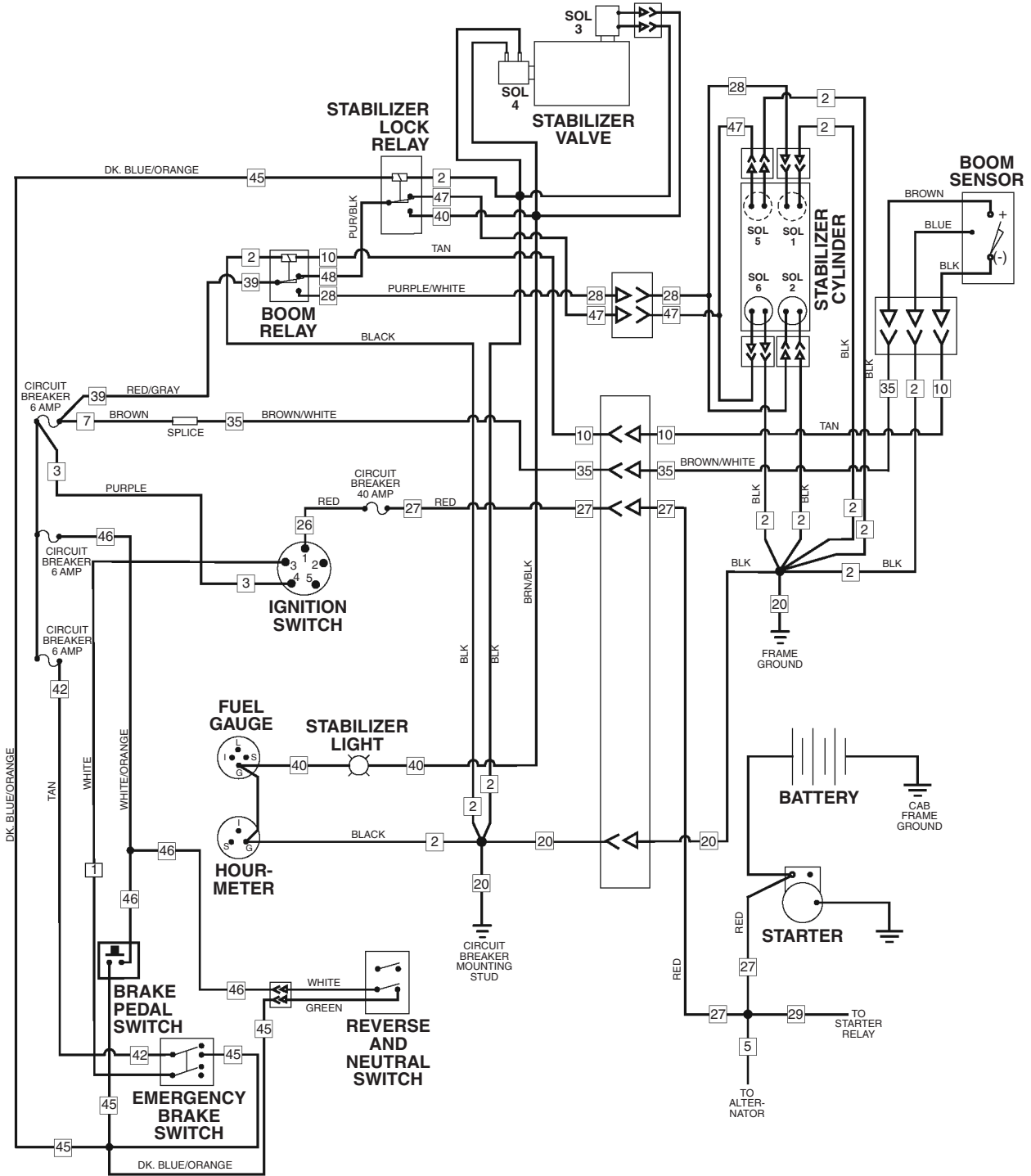

MH0251

8042/10042 Stabilizer Circuit (S/N 0292 thru S/N 9908)

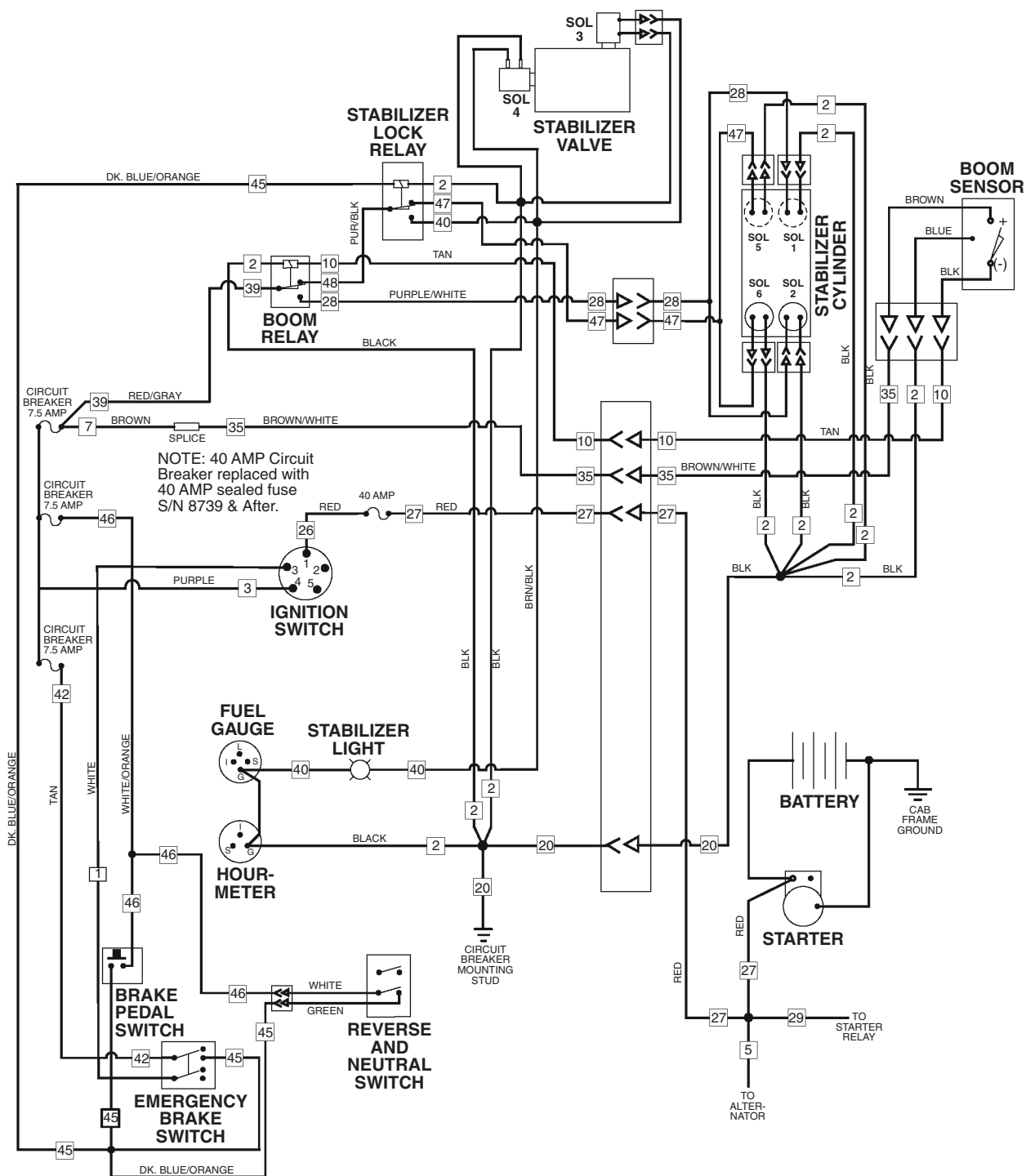

MH0261

10054 Stabilizer Circuit (S/N 9908 & Before)

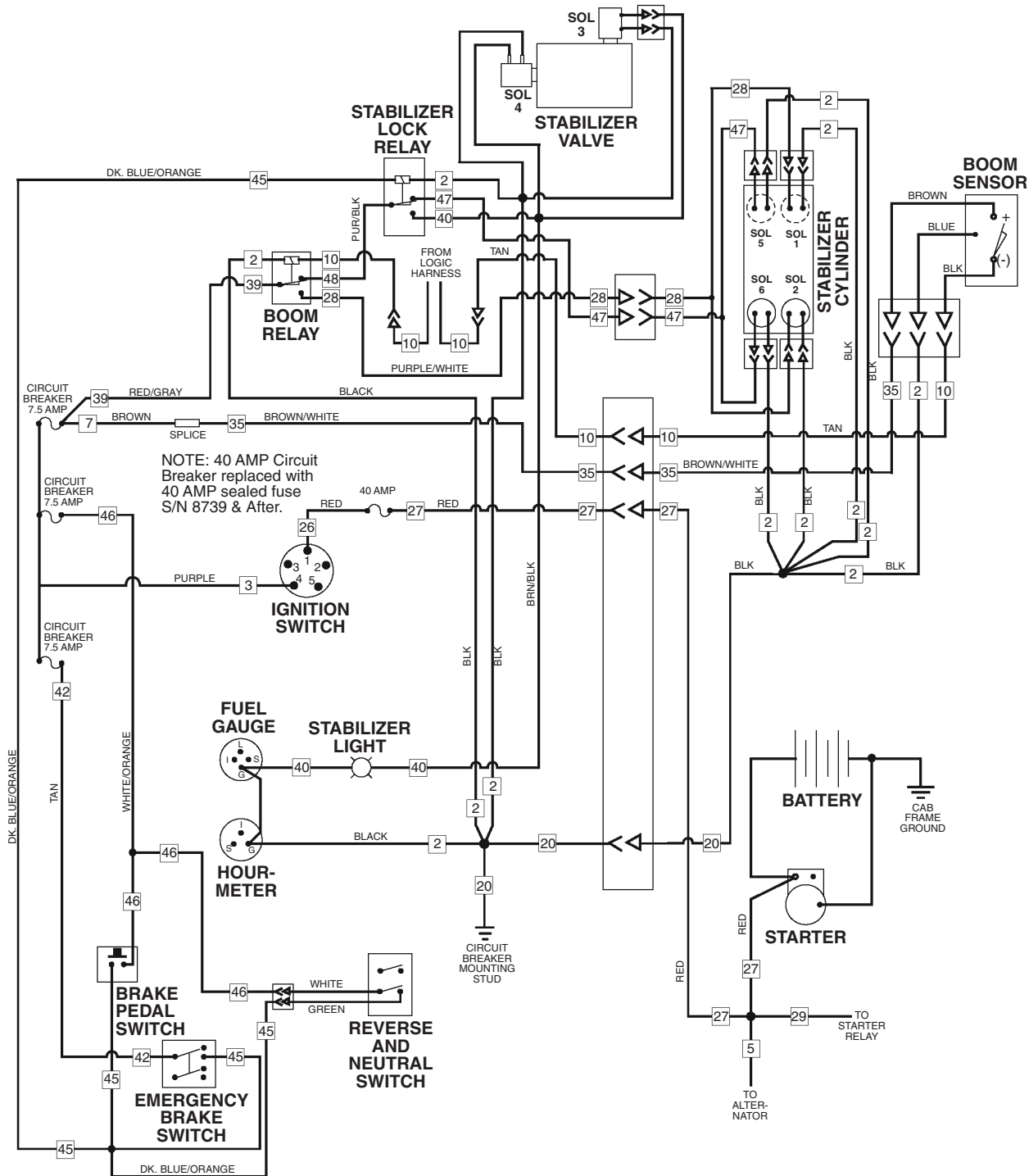

MH0271

10054 Stabilizer Circuit (S/N 9909 & After)

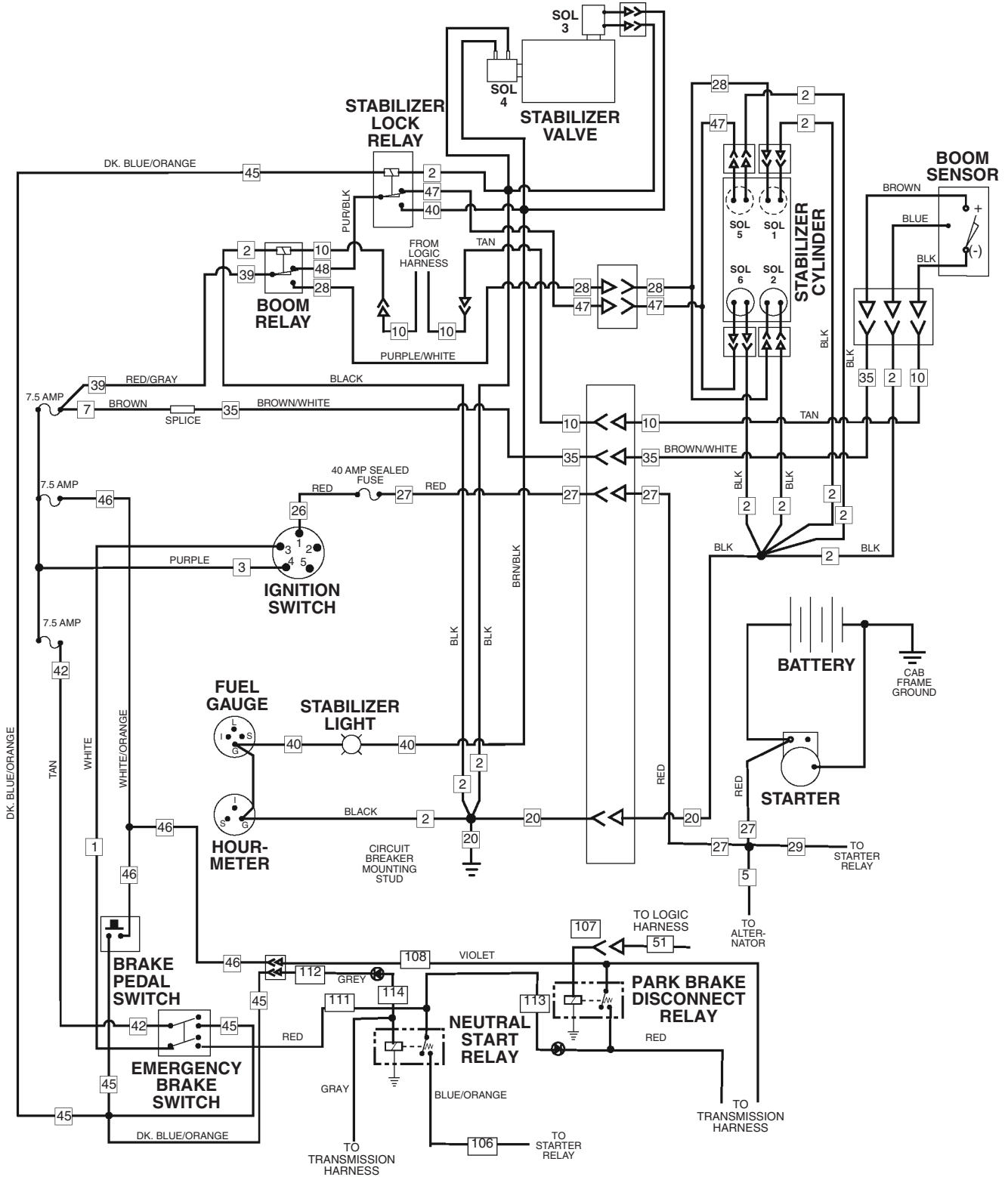

MH0730

NOTES

Stabil-TRAK System

The following information explains the difference between a typical telescopic handler and the benefits that the Stabil-TRAK System provides.

Most telescopic handlers operate within a 3 point stability triangle, as defined by points A, B, and C in the illustration to the right. Point 1 in the illustration represents the center of gravity of an unloaded vehicle. The load has its own center of gravity indicated by Point 3. When the vehicle is loaded, the vehicle and the load become one mass having a combined center of gravity represented by Point 2.

As the boom is lowered or extended, Point 2 will move forward in the 3 point stability triangle, or backward in the stability triangle as the boom is raised. Point 2 can also move left or right toward the edges of the stability triangle if the frame is tilted. As long as Point 2 remains within the boundaries of the 3 point stability triangle, the vehicle will remain stable. If Point 2 ever goes beyond the boundaries of the stability triangle, the vehicle can tip over.

In the locked mode, the exclusive Stabil-TRAK System provides a 4 point stability rectangle by positively locking the frame to the rear axle through the stabilizer cylinder. The vehicle is then supported at four points, A, B, D, and E. While in the locked mode, it is clear that Point 2 will remain within the entire boundary of the 4 point Stabil-TRAK stability rectangle, giving the operator more flexibility in positioning a load.

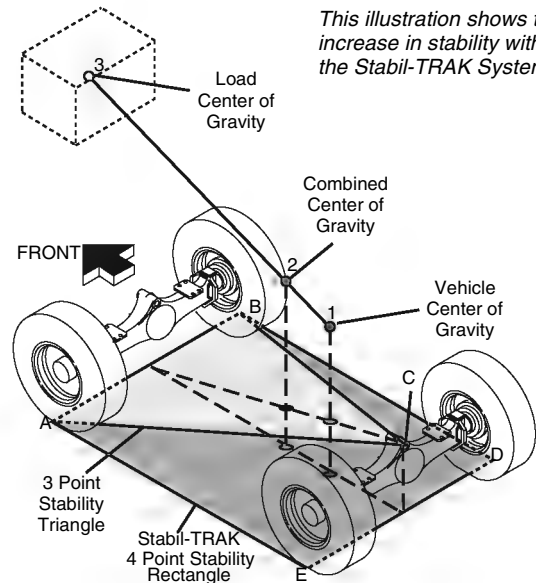

This illustration shows the increase in stability with the Stabil-TRAK System.

PH0712

The Stabil-TRAK System functions in the following three modes:

Free Pivot Mode

With the boom below 40°, the Stabil-TRAK System is in the free pivot mode and the rear axle is allowed to pivot freely.

The frame tilt functions normally, with or without the outriggers down.

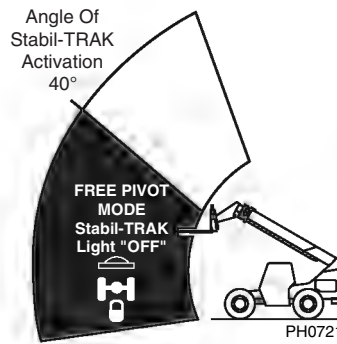

3 Point Stability

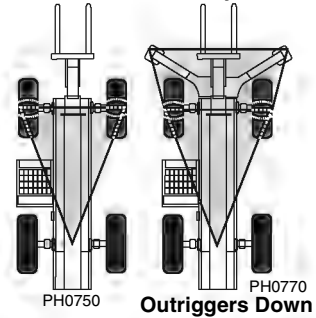

PH0770

Final Positioning Mode

With the boom above 40°, and the vehicle traveling, the Stabil-TRAK System is in the final positioning mode. In this mode the rear axle is unlocked and is allowed to pivot, but will respond SLOWLY to changes in terrain. The frame tilt functions normally in this mode.

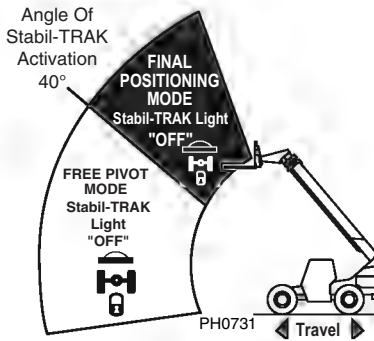

3 Point Stability

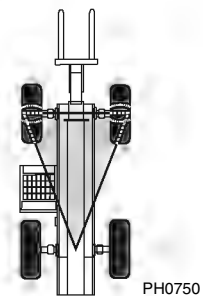

PH0750

Locked Mode

With the boom above 40°, and one or more of the following functions activated, the Stabil-TRAK System is in the locked mode and the rear axle is locked so it is rigid with the frame.

- Engaging the Emergency Brake Switch
- Placing the Travel Select Lever in NEUTRAL
- Depressing and holding the Service Brake Pedal

The frame tilt functions slower than normal in this mode, with or without the outriggers down.

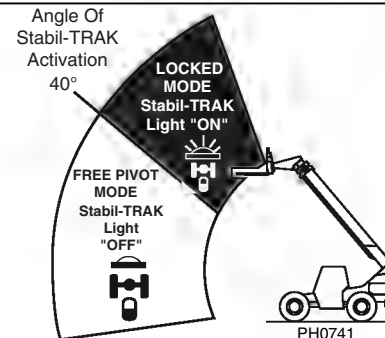

4 Point Stability

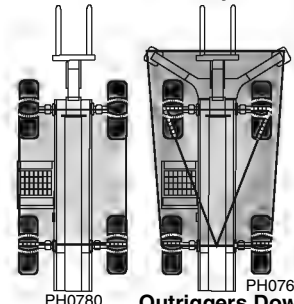

PH0760

Stabil-TRAK System

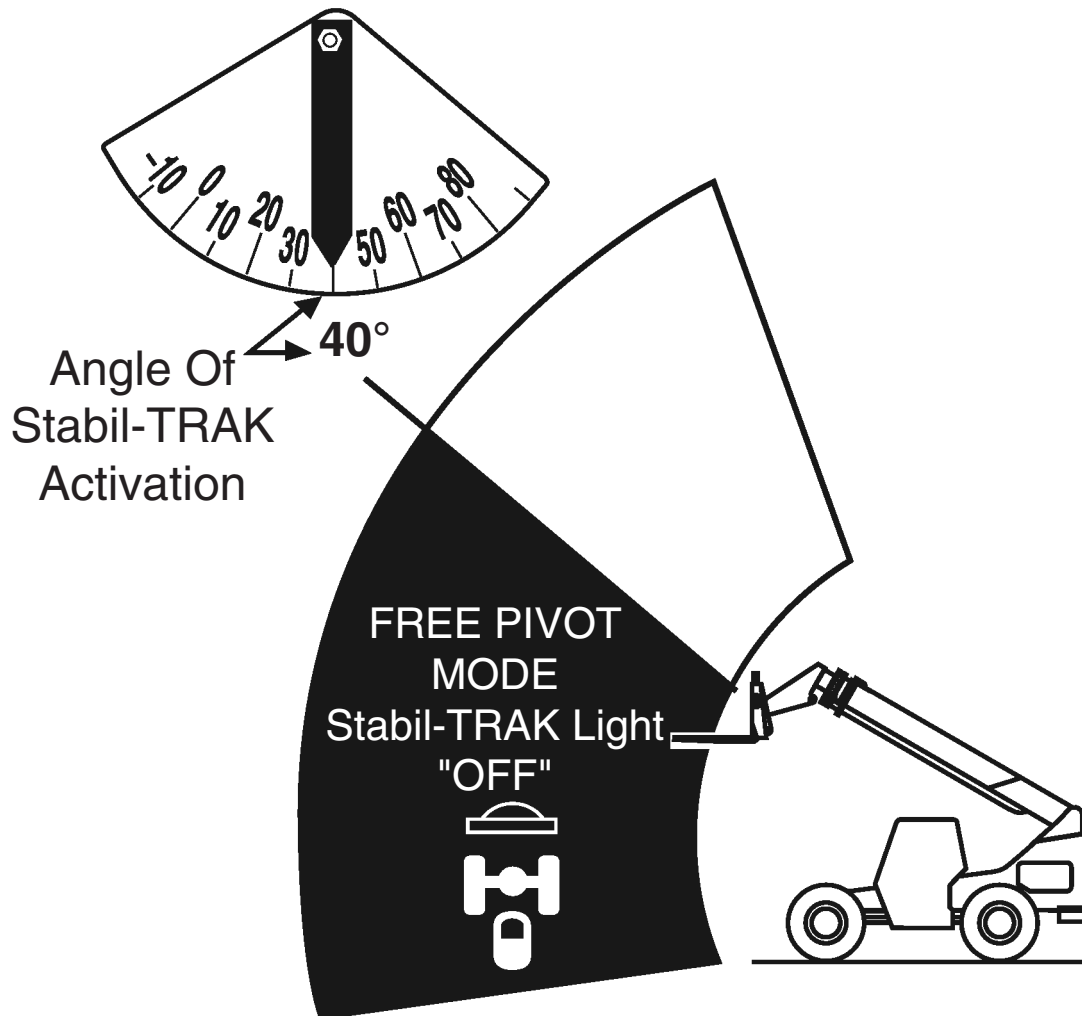

MH0362

Free Pivot Mode

Boom Angles are below 40°.
Rear Axle is allowed to pivot freely.

Stabil-TRAK System

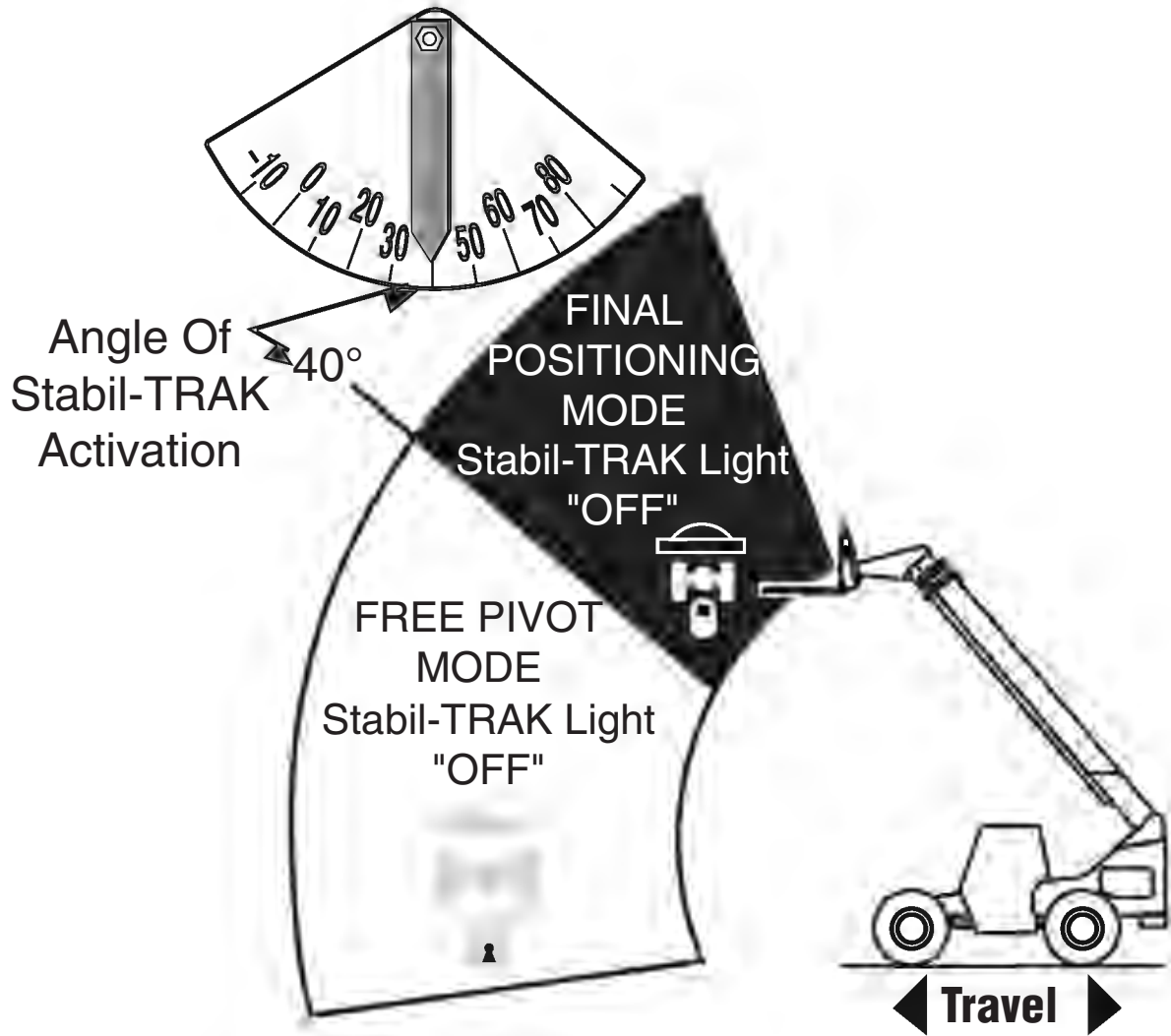

MH0372

Final Positioning Mode

Boom Angles are above 40° with vehicle traveling.

Rear axle is unlocked and is allowed to pivot, but will respond SLOWLY to changes in terrain.

Stabil-TRAK System

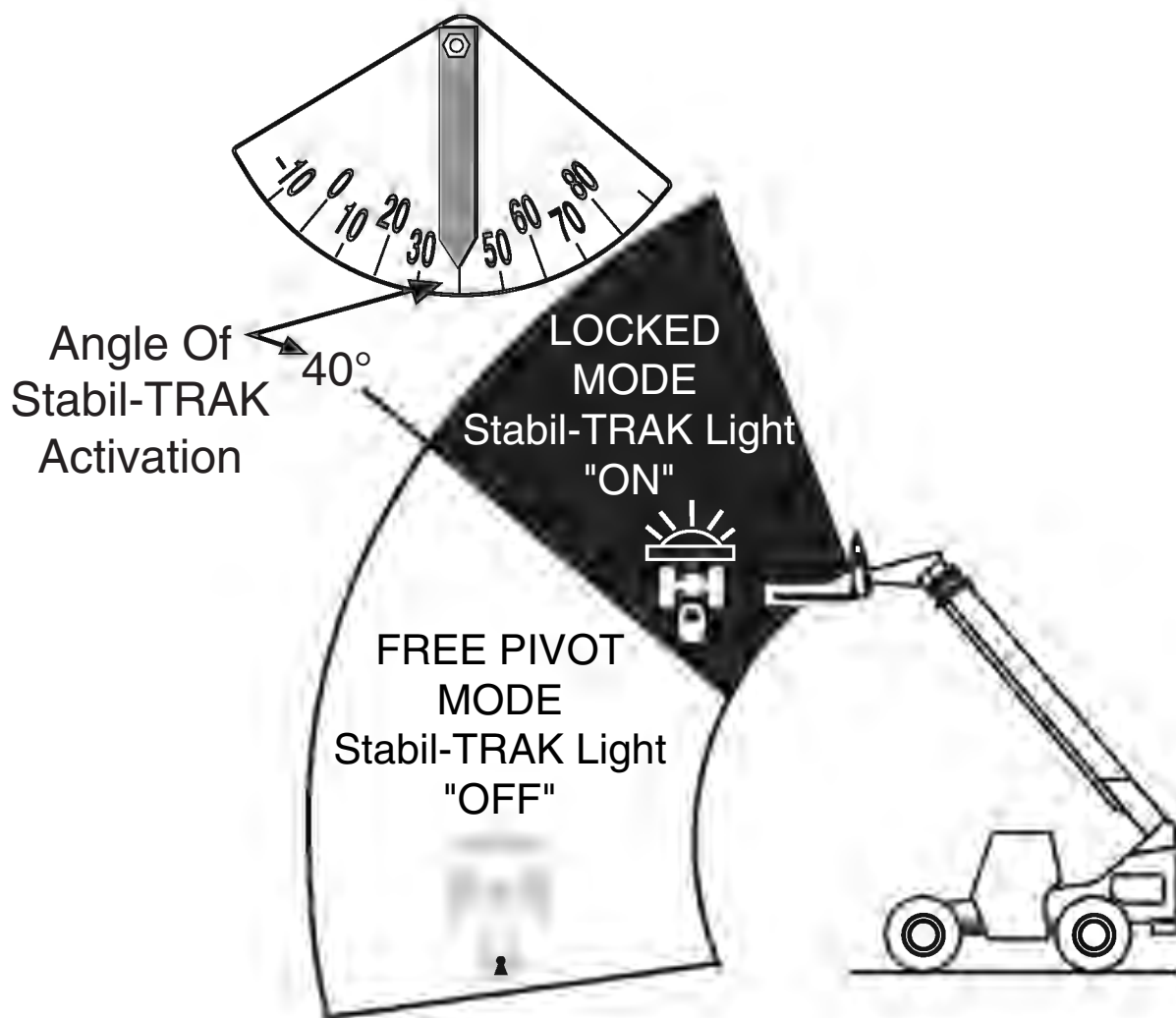

MH0382

Locked Mode

Boom Angles are above 40°.

Rear axle is locked so it is rigid with the frame.

Activated by one or more of these functions:

- Engaging the Emergency Brake Switch
- Placing Travel Select Lever in NEUTRAL
- Depressing and holding the Service Brake Pedal

8042/10042 Stabil-TRAK System Troubleshooting (S/N 9908 & Before)

	FREE PIVOT MODE	FINAL POSITIONING MODE	LOCKED MODE
	Reference page 370 & 371	Reference page 372 & 373	Reference page 374 & 375
Machine Conditions	Ignition On Boom Below 40° Trans. Fwd. or Rev.	Ignition On Boom Above 40° SB Released Trans. Fwd. or Rev.	Ignition On Boom Above 40° PB & SB Applied Trans. Neutral
Switch/ Relay Solenoid			
Solenoid 1	E	DE	DE
Solenoid 2	E	DE	DE
Solenoid 3	DE	DE	E
Solenoid 4	DE	DE	E
Solenoid 5	DE	E	DE
Solenoid 6	DE	E	DE
Boom Angle Sensor	C	O	O
Boom Switch Relay	E	DE	DE
Stabilizer Lock Relay	DE	DE	E
Stabilizer Light	Off	Off	On

Definitions:

PB = Park Brake

SB = Service Brake

DE = De-energized

E = Energized

C = Closed

O = Open

8042/10042
Stabil-TRAK Electrical Circuit
Ignition "OFF"
(S/N 9908 & Before)

Ignition "OFF"		

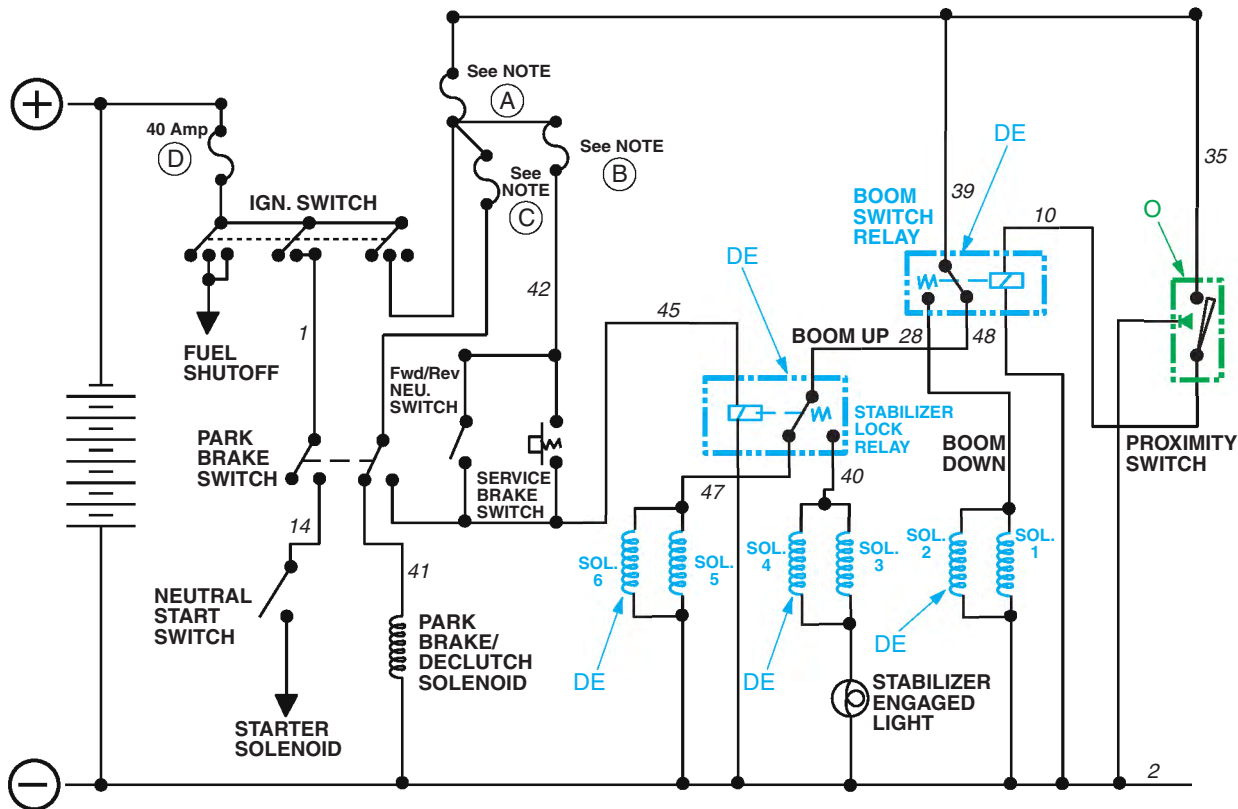

LEGEND

- DE = De-energized
- E = Energized
- O = Open
- PB = Park Brake
- SB = Service Brake

NOTE:

- 7.5 Amp - S/N 292 & After
- 6.0 Amp - S/N 291 & Before

S/N 8042/10042-0291 & Before

Boom Switch Relay located in Kick Panel.
Stabilizer Lock Relay located under Dash to the left side of the Steering Wheel

S/N 8042/10042-0292 & After

Boom Switch and Stabilizer Lock Relays located in Kick Panel

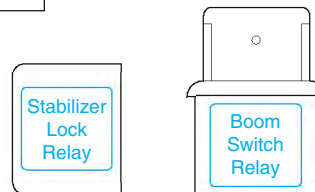
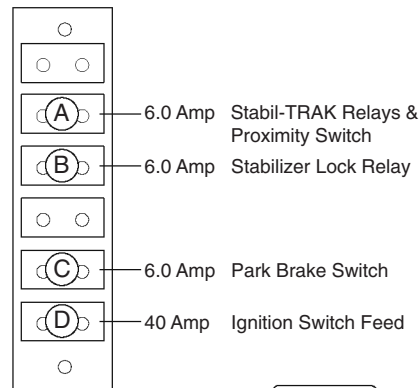
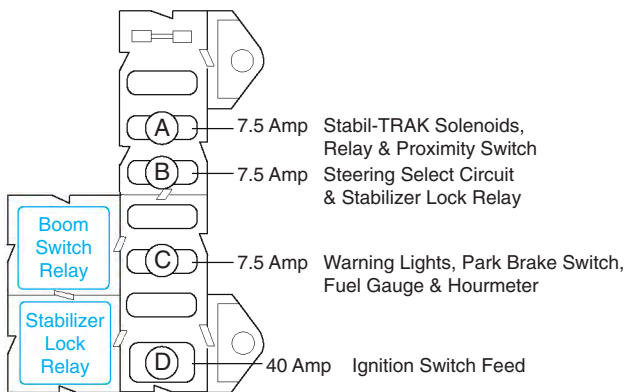

SH0402

SECTION 10

8042/10042
 Stabil-TRAK Electrical Circuit
 Free Pivot Mode
 (S/N 9908 & Before)

Free Pivot Mode	1.	Ignition "ON"	4.	SB & PB Released
	2.	Transmission in Fwd. or Rev.	5.	
	3.	Boom Below 40°	6.	

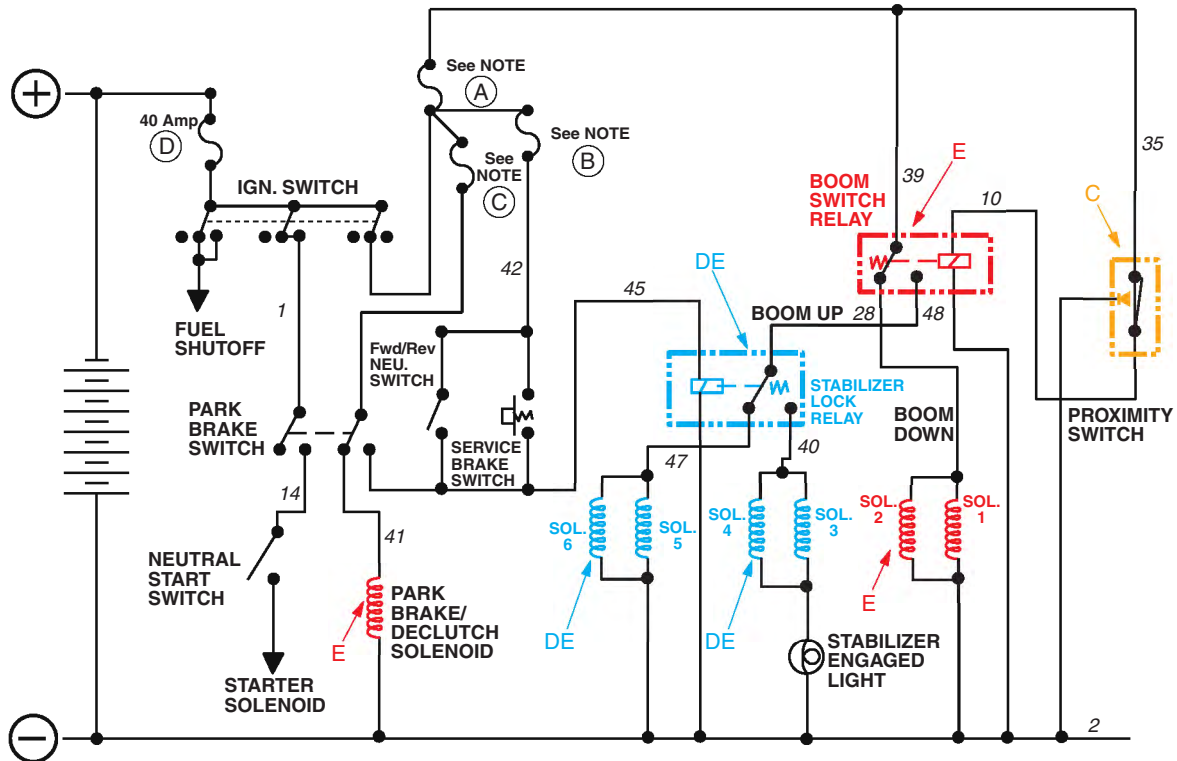

LEGEND

- DE = De-energized
- E = Energized
- C = Closed
- PB = Park Brake
- SB = Service Brake

NOTE:

7.5 Amp - S/N 292 & After
 6.0 Amp - S/N 291 & Before

S/N 8042/10042-0291 & Before

Boom Switch Relay located in Kick Panel.
 Stabilizer Lock Relay located under Dash to the left side of the Steering Wheel

S/N 8042/10042-0292 & After

Boom Switch and Stabilizer Lock Relays located in Kick Panel

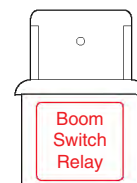
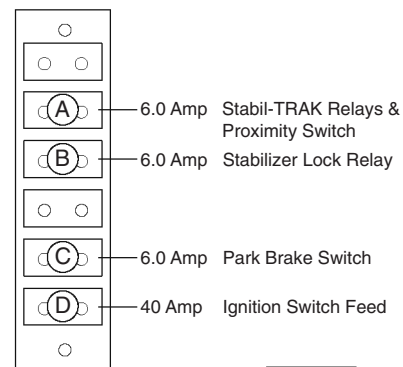
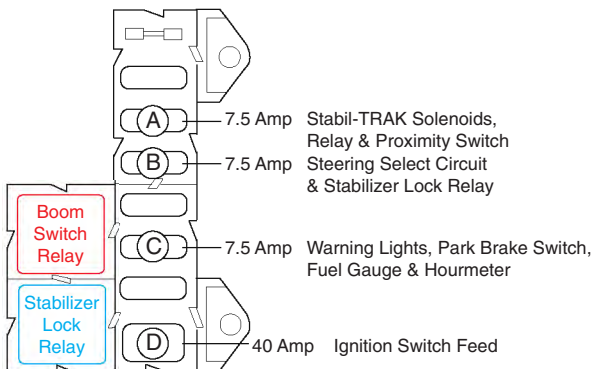

SH0581

8042/10042 Stabil-TRAK Hydraulic Circuit

Free Pivot Mode

(S/N 9908 & Before)

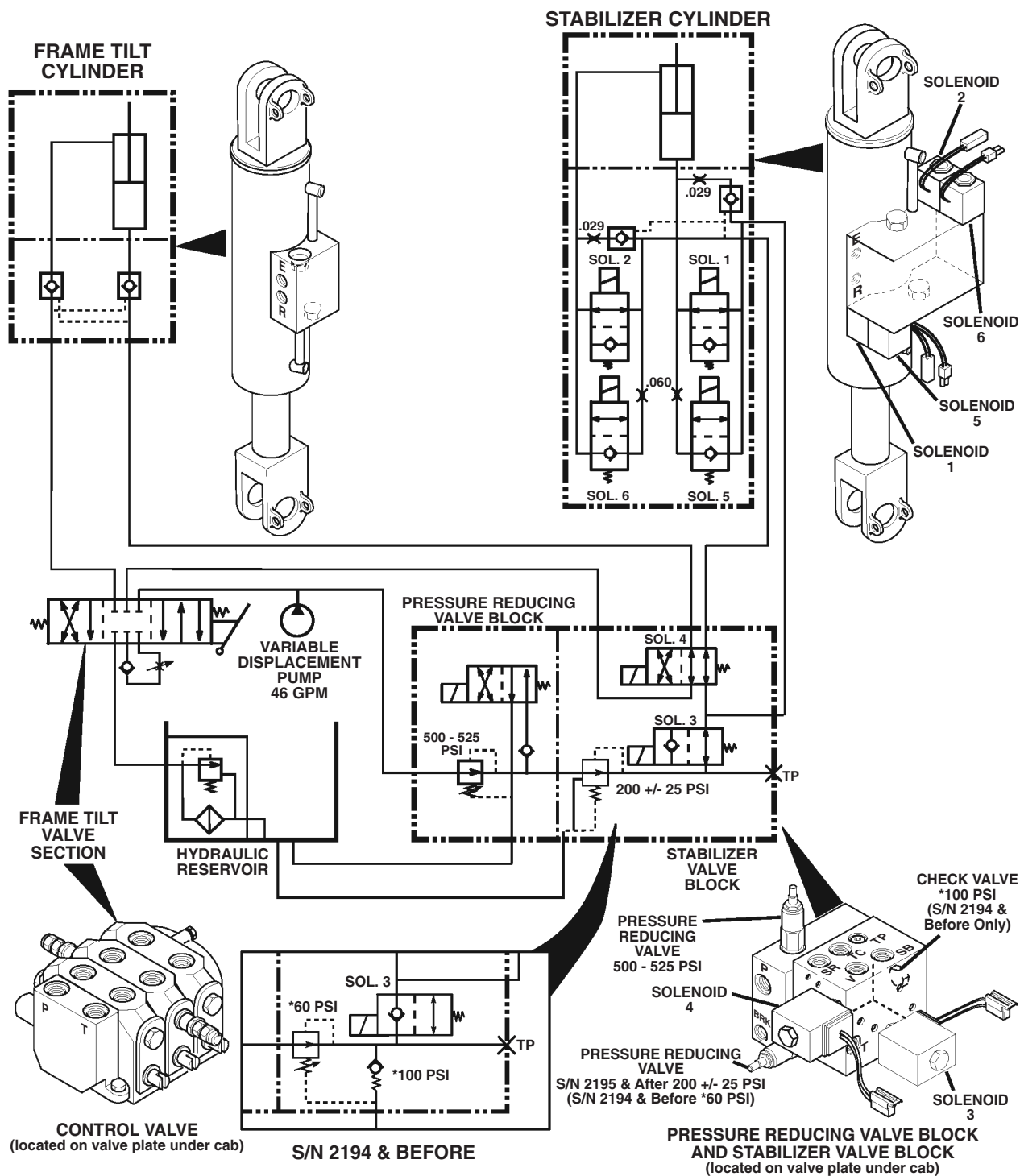

SH0570

CONDITIONS:

Boom below 40°, vehicle stopped, and transmission in forward or reverse.

Solenoids 1 and 2 are energized to permit flow of rear axle stabilizer cylinder oil to hydraulic reservoir and normal frame tilt.

Solenoids 3, 4, 5, and 6 are de-energized.

If vehicle is stopped by service brakes, or park brake switch, or transmission in neutral; the same conditions apply.

SECTION 10

**8042/10042
Stabil-TRAK Electrical Circuit
Final Positioning Mode
(S/N 9908 & Before)**

Final Positioning Mode	1.	2.	3.	4.	5.	6.
Conditions	Ignition "ON"	Transmission in Fwd. or Rev.	Boom Above 40°	SB Released		

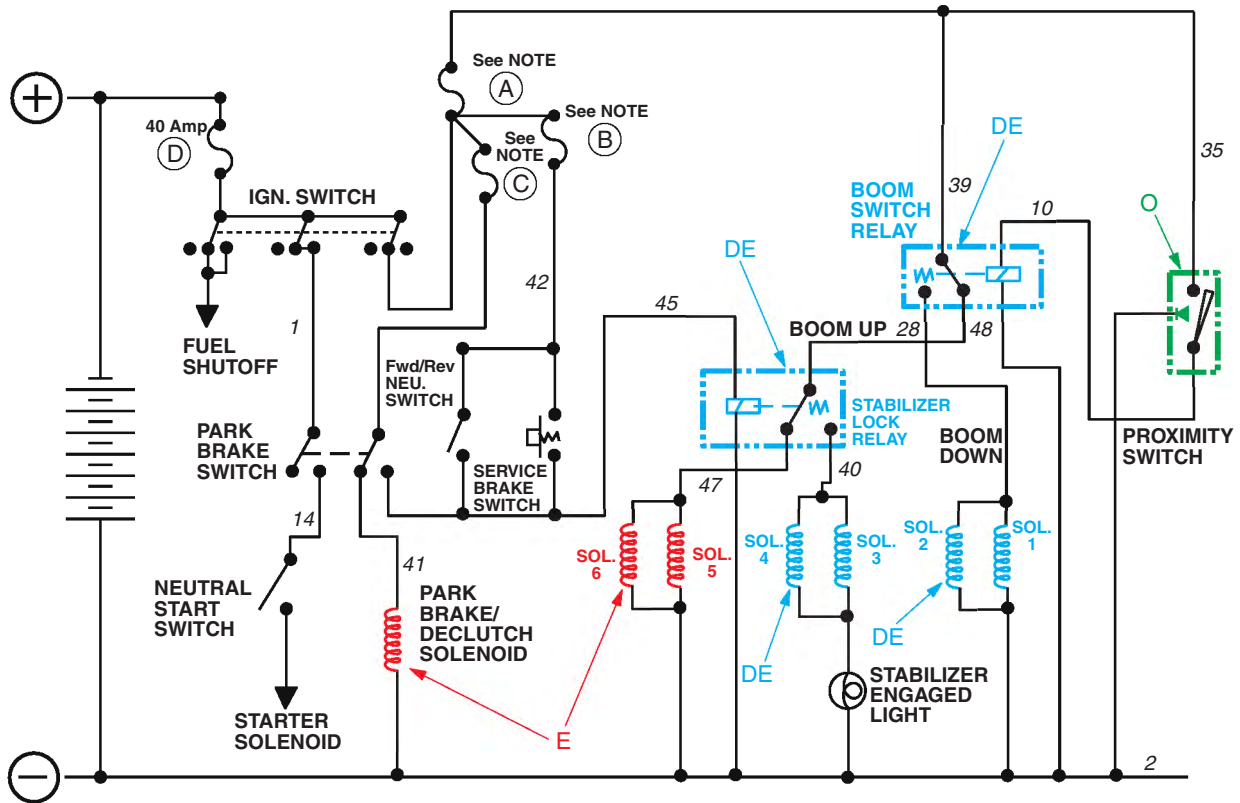

LEGEND

- DE = De-energized
- E = Energized
- O = Open
- PB = Park Brake
- SB = Service Brake

NOTE:

- 7.5 Amp - S/N 292 & After
- 6.0 Amp - S/N 291 & Before

S/N 8042/10042-0291 & Before

Boom Switch Relay located in Kick Panel.
Stabilizer Lock Relay located under Dash to the left side of the Steering Wheel

S/N 8042/10042-0292 & After

Boom Switch and Stabilizer Lock Relays located in Kick Panel

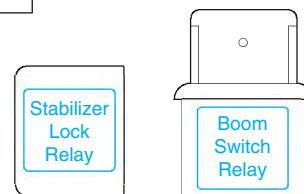
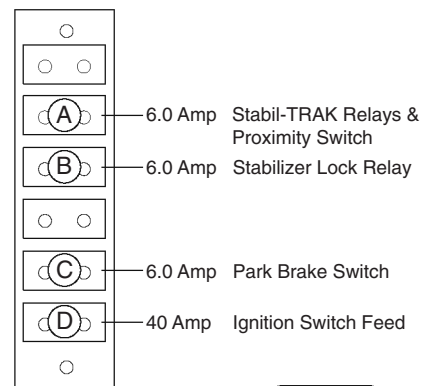
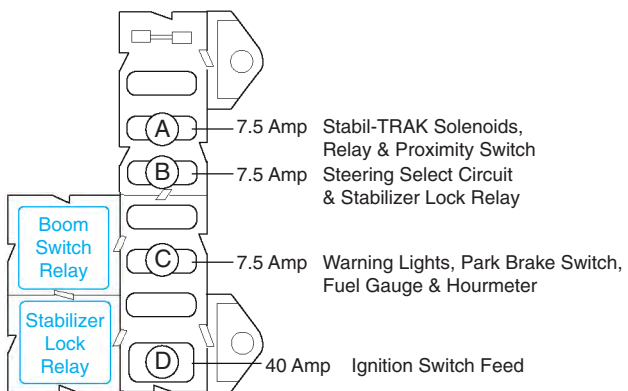

SH0561

SECTION 10

**8042/10042
Stabil-TRAK Electrical Circuit
Locked Mode
(S/N 9908 & Before)**

Locked Mode	1. Ignition "ON"	4. SB & PB Applied
Conditions	2. Transmission in Neutral	5.
	3. Boom Above 40°	6.

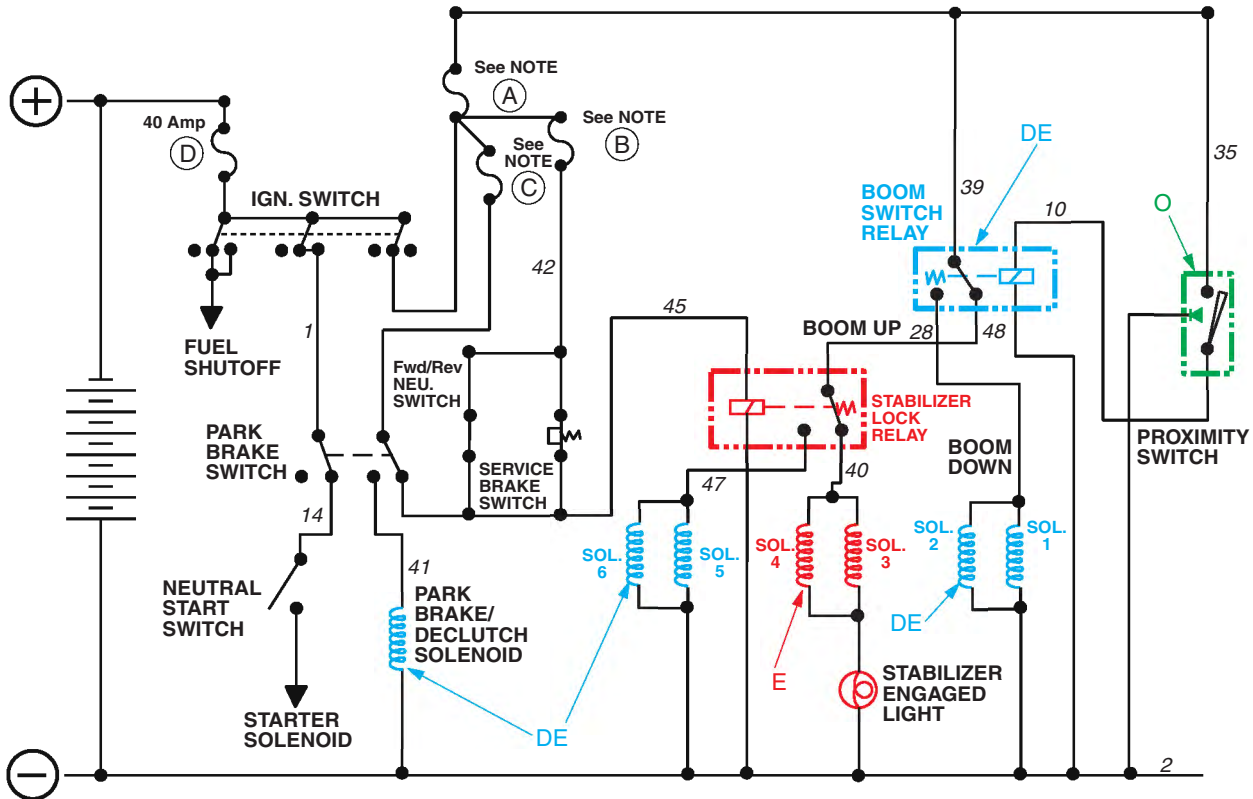

LEGEND

- DE = De-energized
- E = Energized
- O = Open
- PB = Park Brake
- SB = Service Brake

NOTE:

- 7.5 Amp - S/N 292 & After
- 6.0 Amp - S/N 291 & Before

S/N 8042/10042-0291 & Before

Boom Switch and Stabilizer Lock Relays located in Kick Panel.
Stabilizer Lock Relay located under Dash to the left side of the Steering Wheel

S/N 8042/10042-0292 & After
Boom Switch and Stabilizer Lock Relays located in Kick Panel

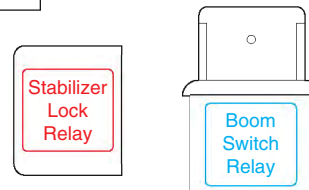
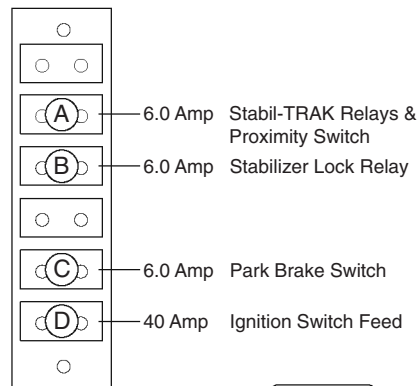
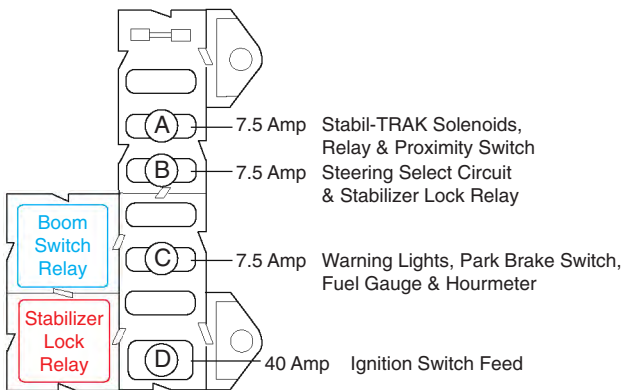

SH0541

8042/10042 Stabil-TRAK Hydraulic Circuit Locked Mode (S/N 9908 & Before)

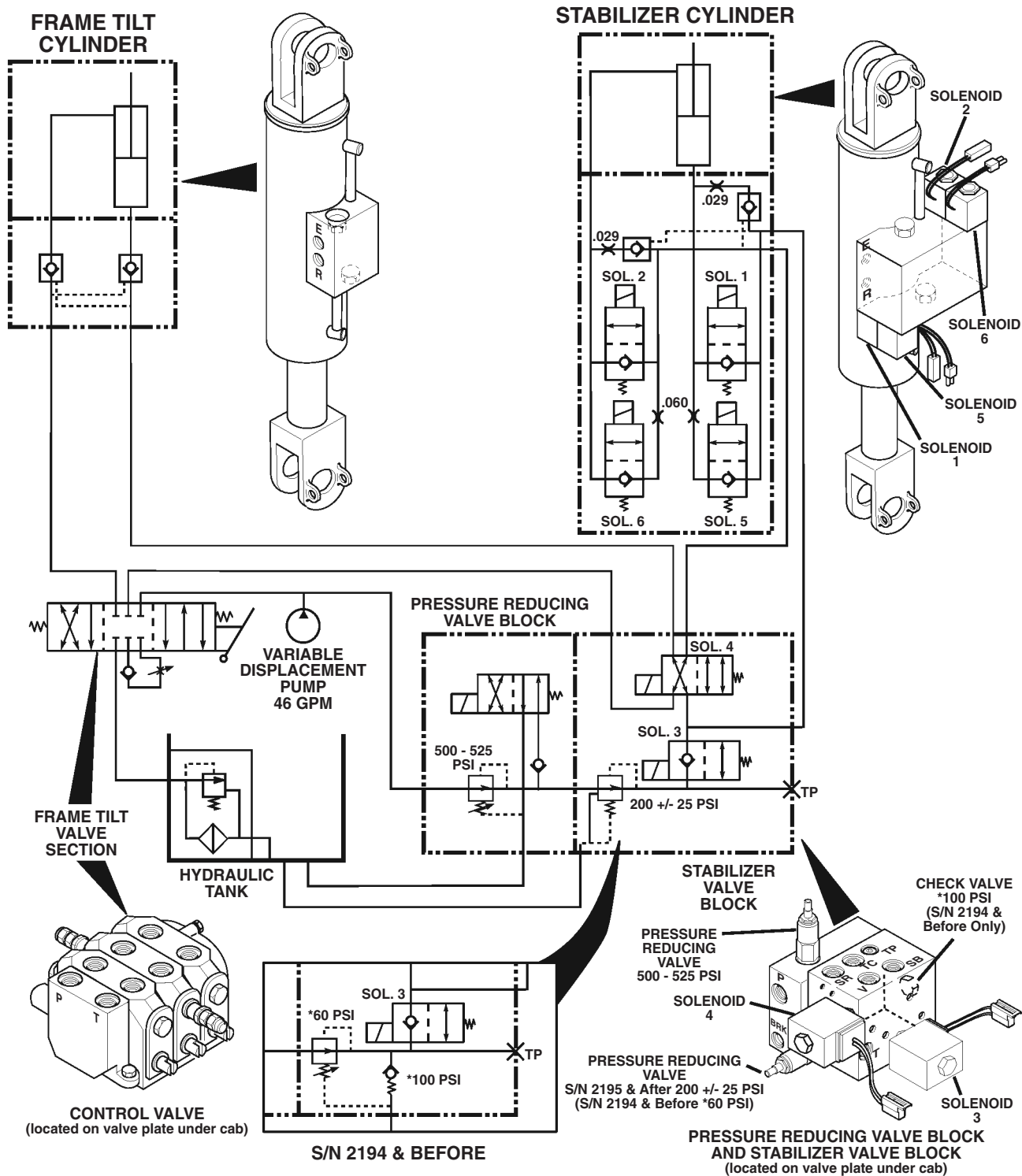

SH0530

CONDITIONS:

Boom raised above 40° and vehicle stopped with service brake on, or park brake switch engaged, or transmission in neutral.

Solenoids 1, 2, 5, and 6 de-energized and solenoids 3 and 4 energized.

Rear axle is locked. If the frame is tilted, the cylinders are slaved and tilt speed is slowed by .029 orifices.

8042/10042

Stabil-TRAK System Troubleshooting (S/N 9909 & After)

	FREE PIVOT MODE	FINAL POSITIONING MODE	LOCKED MODE
	Reference page 378 & 379	Reference page 380 & 381	Reference page 382 & 383
Machine Conditions	Ignition On Boom Below 40° Trans. Fwd. or Rev.	Ignition On Boom Above 40° SB Released Trans. Fwd. or Rev.	Ignition On Boom Above 40° PB & SB Applied Trans. Neutral
Switch/ Relay Solenoid			
Solenoid 1	E	DE	DE
Solenoid 2	E	DE	DE
Solenoid 3	DE	DE	E
Solenoid 4	DE	DE	E
Solenoid 5	DE	E	DE
Solenoid 6	DE	E	DE
Boom Angle Sensor	C	O	O
Boom Switch Relay	E	DE	DE
Stabilizer Lock Relay	DE	DE	E
Stabilizer Light	Off	Off	On
Park Brake Disconnect Relay	E	E	DE
Neutral Start Relay	DE	DE	E

Definitions:

PB = Park Brake

SB = Service Brake

DE = De-energized

E = Energized

C = Closed

O = Open

8042/10042
Stabil-TRAK Electrical Circuit
Ignition "OFF"
(S/N 9909 & After)

Ignition "OFF"		

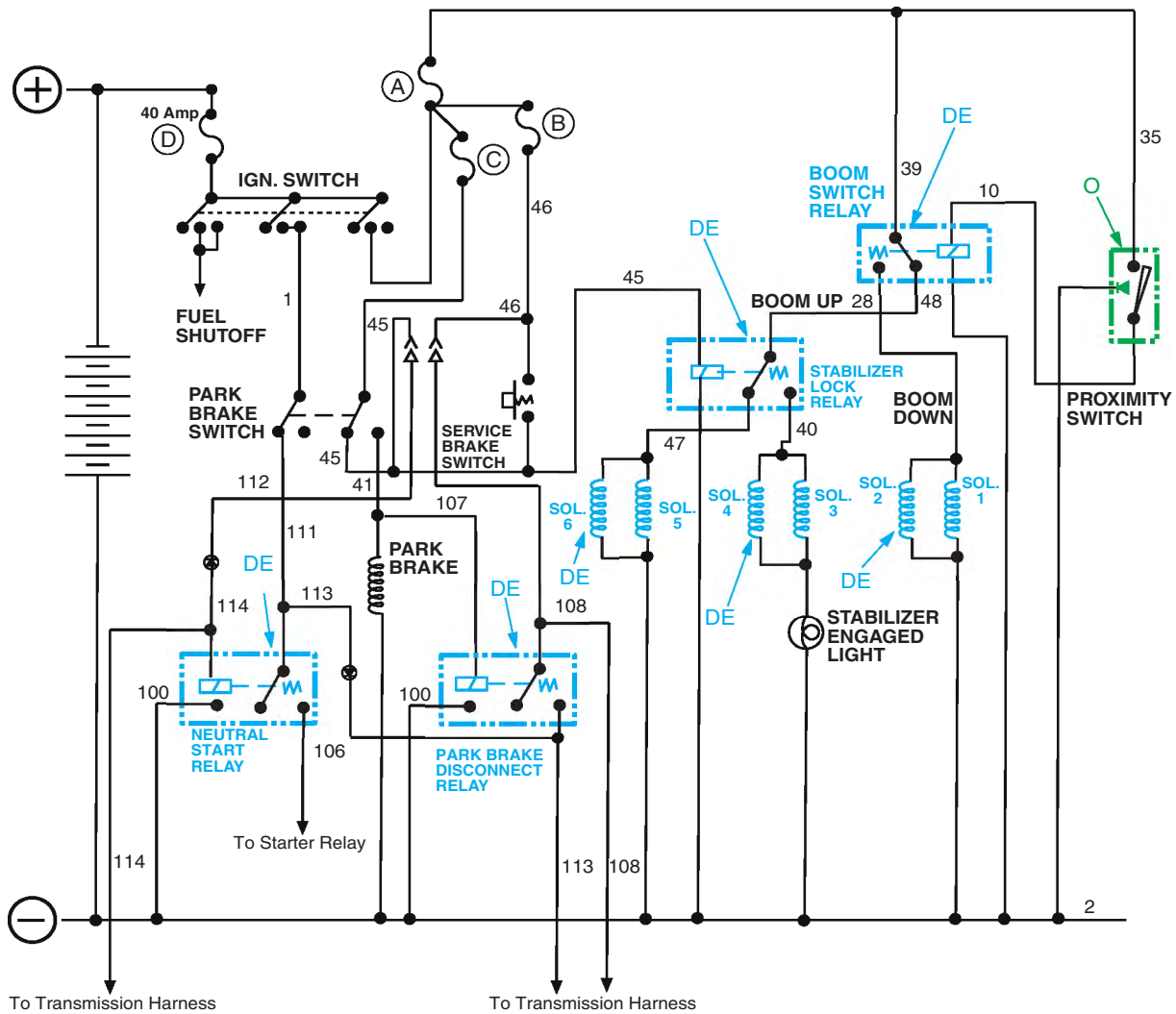

RELAY LOCATIONS

Relay Block located under Dash attached to Back of Bulkhead with Velcro

LEGEND

- DE = De-energized
- E = Energized
- O = Open
- PB = Park Brake
- SB = Service Brake



Boom Switch and Stabilizer Lock Relays located in Kick Panel

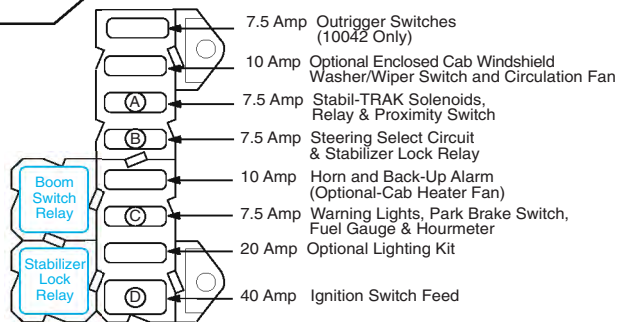

SECTION 10

8042/10042
 Stabil-TRAK Electrical Circuit
 Free Pivot Mode
 (S/N 9909 & After)

Free Pivot Mode	1.	Ignition "ON"	4.	SB & PB Released
	2.	Transmission in Fwd. or Rev.	5.	
	3.	Boom Below 40°	6.	
Conditions				

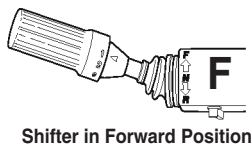
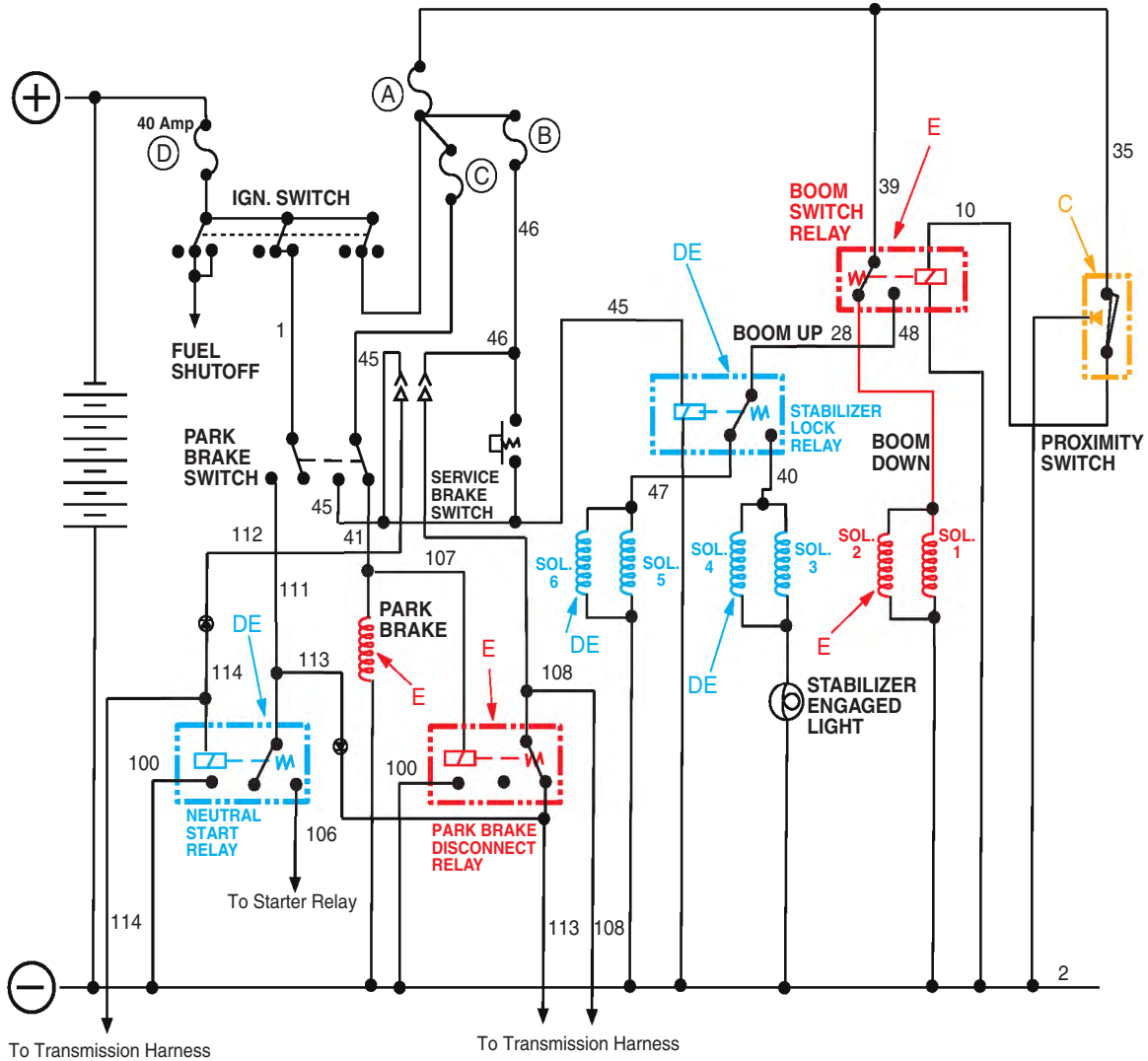

LEGEND
 DE = De-energized
 E = Energized
 O = Open
 C = Closed
 PB = Park Brake
 SB = Service Brake

RELAY LOCATIONS

Relay Block located under Dash and attached to Back of Bulkhead with Velcro



Boom Switch and Stabilizer Lock Relays located in Kick Panel

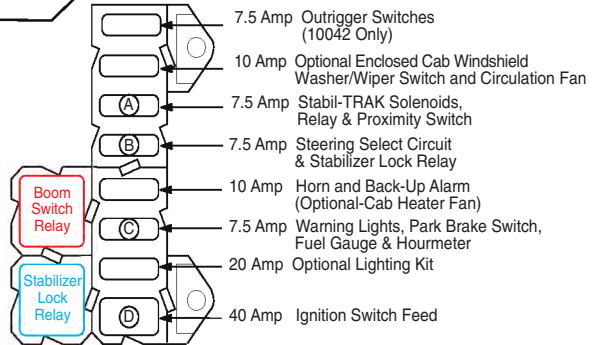

SH1300

8042/10042 Stabil-TRAK Hydraulic Circuit

Free Pivot Mode

(S/N 9909 & After)

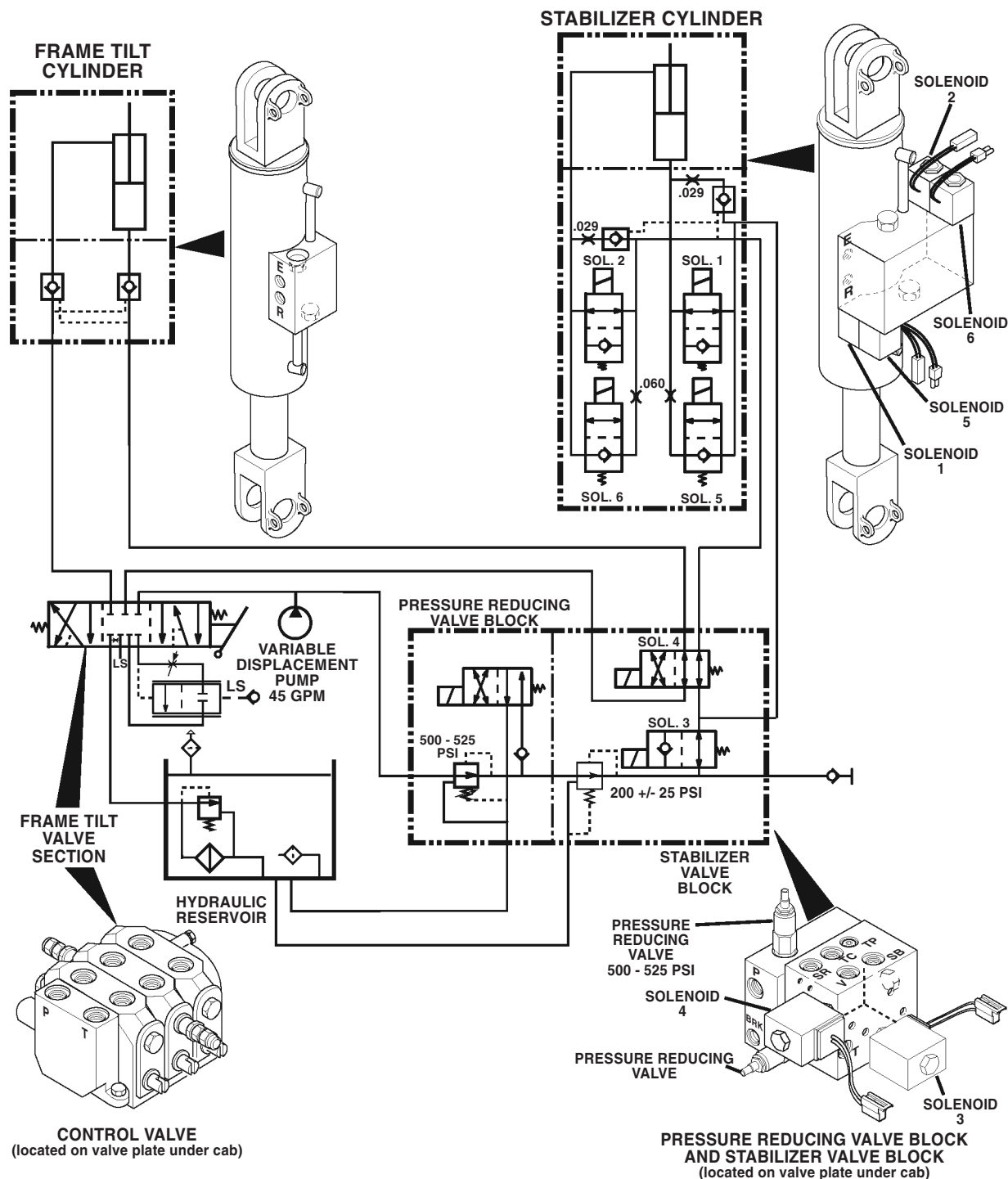

SH1170

CONDITIONS:

Boom below 40°, vehicle stopped, and transmission in forward or reverse.

Solenoids 1 and 2 are energized to permit flow of rear axle stabilizer cylinder oil to hydraulic reservoir and normal frame tilt.

Solenoids 3, 4, 5, and 6 are de-energized.

If vehicle is stopped by service brakes, or park brake switch, or transmission in neutral; the same conditions apply.

SECTION 10

**8042/10042
Stabil-TRAK Electrical Circuit
Final Positioning Mode
(S/N 9909 & After)**

Final Positioning Mode	1. Ignition "ON"	4. SB & PB Released
Conditions	2. Transmission in Fwd. or Rev.	5.
	3. Boom Above 40°	6.

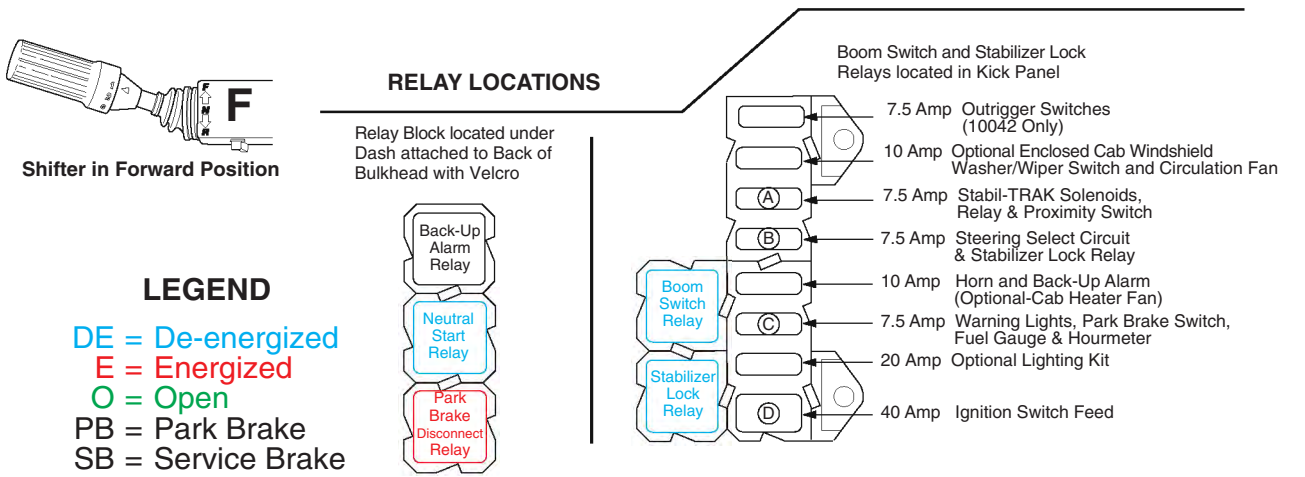
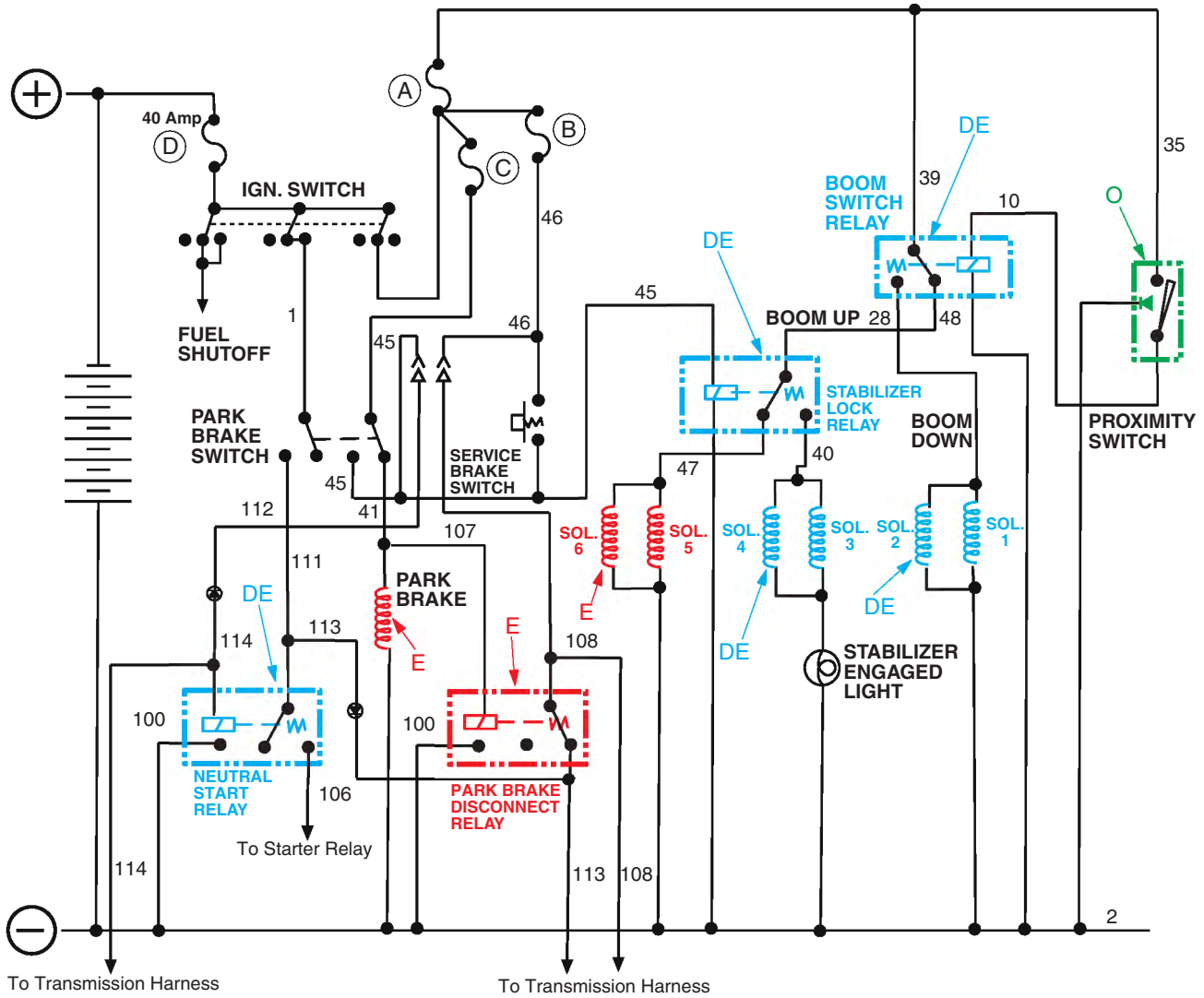

SH1310

SECTION 10

**8042/10042
Stabil-TRAK Electrical Circuit
Locked Mode
(S/N 9909 & After)**

Locked Mode	1. Ignition "ON"	4. SB & PB Applied
Conditions	2. Transmission in Neutral	5.
	3. Boom Above 40°	6.

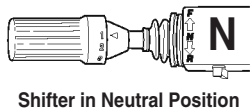
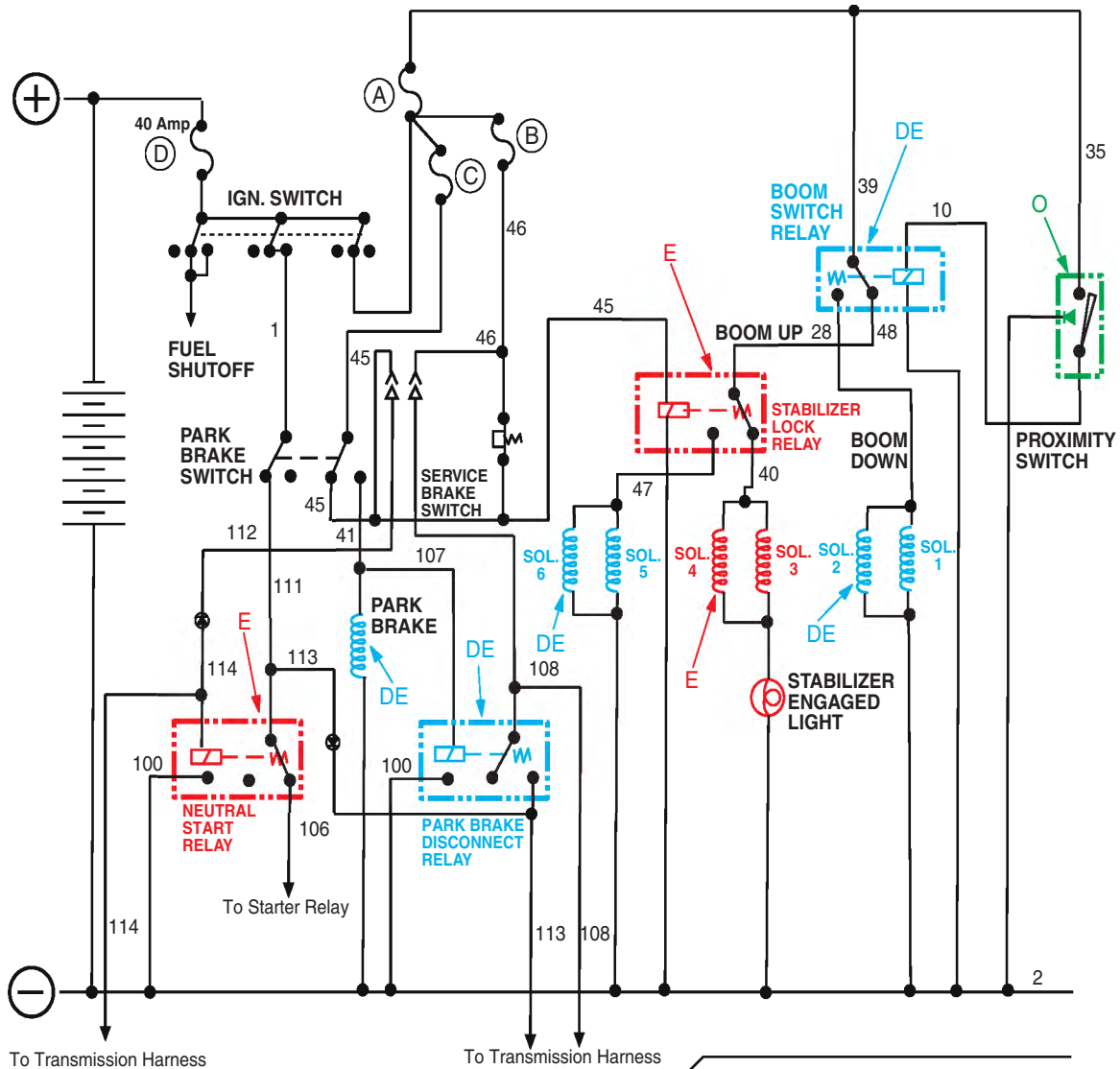

- LEGEND**
- DE = De-energized
 - E = Energized
 - O = Open
 - PB = Park Brake
 - SB = Service Brake

RELAY LOCATIONS

Relay Block located under Dash and attached to Back of Bulkhead with Velcro



Boom Switch and Stabilizer Lock Relays located in Kick Panel

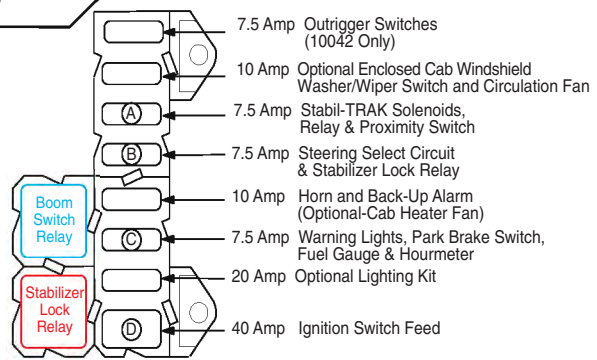

8042/10042 Stabil-TRAK Hydraulic Circuit Locked Mode (S/N 9909 & After)

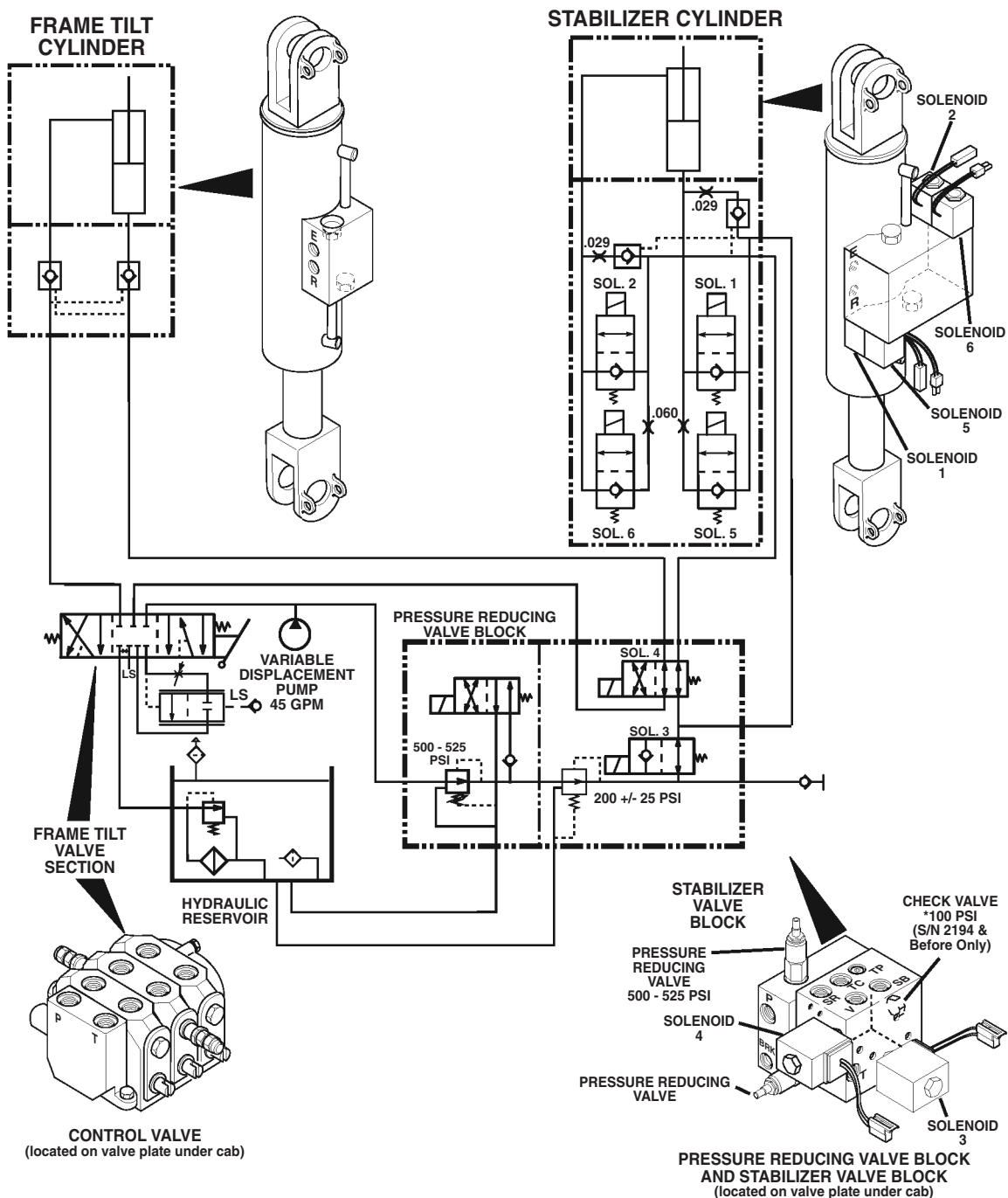

SH1190

CONDITIONS:

Boom raised above 40° and vehicle stopped with service brake on, or park brake switch engaged, or transmission in neutral.

Solenoids 1, 2, 5, and 6 de-energized and solenoids 3 and 4 energized.

Rear axle is locked. If the frame is tilted, the cylinders are slaved and tilt speed is slowed by .029 orifices.

SECTION 10

10054 Stabil-TRAK System Troubleshooting (S/N 9908 & Before)

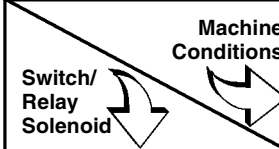
	BOOM EXTEND MODE 1	BOOM EXTEND MODE 2	BOOM EXTEND MODE 3	BOOM EXTEND MODE 4	BOOM EXTEND MODE 5
	Reference page 386	Reference page 387	Reference page 388	Reference page 389	Reference page 390
	Ignition On Boom Below 40° Boom Retracted PB & SB Released Trans. Fwd. or Rev. Outriggers Up	Ignition On Boom Below 40° Boom Extended PB & SB Released Trans. Fwd. or Rev. Outriggers Up	Ignition On Boom Below 40° Boom Extended PB & SB Applied Trans. Neutral Outriggers Down	Ignition On Boom Above 40° Boom Retracted PB & SB Released Trans. Fwd. or Rev. Outriggers Up	Ignition On Boom Above 40° Boom Retracted PB & SB Released Trans. Fwd. or Rev. Outriggers Down
Solenoid 1	E	E	E	DE	DE
Solenoid 2	E	E	E	DE	DE
Solenoid 3	DE	DE	DE	DE	DE
Solenoid 4	DE	DE	DE	DE	DE
Solenoid 5	DE	DE	DE	E	E
Solenoid 6	DE	DE	DE	E	E
Boom Angle Sensor	C	C	O	O	O
Boom Relay	E	E	E	DE	DE
Stabilizer Lock Relay	DE	DE	E	DE	DE
Stabilizer Light	Off	Off	On	Off	On

BOOM EXTEND INTERLOCK SYSTEM TROUBLESHOOTING

Boom Extend Proximity Switch	C	O	O	C	C
Boom Extend Interlock Relay	E	DE	DE	E	E
Boom Extend Lockout Relay	E	DE	DE	E	E
Outrigger Lockout Relay	E	DE	DE	E	E
Outrigger Pressure Switches	O	O	C	O	C
Left Outrigger Lockout Relay	DE	DE	E	DE	DE
Right Outrigger Lockout Relay	DE	DE	E	DE	DE
Stabilizer Interlock Relay	DE	DE	E	DE	E
Stabilizer Lock-Up Relay	DE	DE	E	DE	DE
Extend Circuit Solenoid Valve	E	DE	E	E	E
Park Brake Solenoid Valve	E	E	DE	E	E
Park Brake Interlock Relay	DE	DE	E	DE	DE

NOTE: If an outrigger is up or a pressure switch is defective, boom on 10054 will not extend beyond 42 series extension limit.

Definitions:

- Boom Retracted = Less than 42 series extension limit
- Boom Extended = Boom at 42 series extension limit or greater (See Figure)
- PB = Park Brake
- SB = Service Brake
- DE = De-energized
- E = Energized
- C = Closed
- O = Open

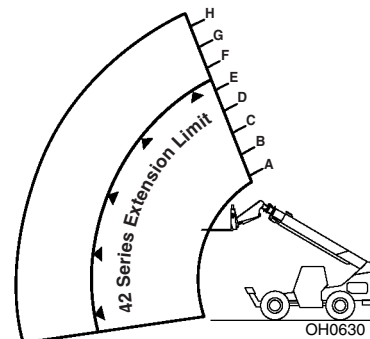

10054 Stabil-TRAK System Troubleshooting (S/N 9908 & Before)

	BOOM EXTEND MODE 6	BOOM EXTEND MODE 7	BOOM EXTEND MODE 8	BOOM EXTEND MODE 9	
	Reference page 391	Reference page 392	Reference page 393	Reference page 394	
Switch/ Relay Solenoid	Machine Conditions				
	Ignition On Boom Above 40° Boom Retracted PB & SB Applied Trans. Neutral Outriggers Up	Ignition On Boom Above 40° Boom Retracted PB & SB Applied Trans. Neutral Outriggers Down	Ignition On Boom Above 40° Boom Extended PB & SB Applied Trans. Neutral Outriggers Up	Ignition On Boom Above 40° Boom Extended PB & SB Applied Trans. Neutral Outriggers Down	
Solenoid 1	DE	DE	DE	DE	
Solenoid 2	DE	DE	DE	DE	
Solenoid 3	E	E	E	E	
Solenoid 4	E	E	E	E	
Solenoid 5	DE	DE	DE	DE	
Solenoid 6	DE	DE	DE	DE	
Boom Angle Sensor	O	O	O	O	
Boom Relay	DE	DE	DE	DE	
Stabilizer Lock Relay	E	E	E	E	
Stabilizer Light	On	On	On	On	
BOOM EXTEND INTERLOCK SYSTEM TROUBLESHOOTING					
Boom Extend Proximity Switch	C	C	O	O	
Boom Extend Interlock Relay	E	E	DE	DE	
Boom Extend Lockout Relay	E	E	DE	DE	
Outrigger Lockout Relay	E	E	DE	DE	
Outrigger Pressure Switches	O	C	O	C	
Left Outrigger Lockout Relay	DE	DE	DE	E	
Right Outrigger Lockout Relay	DE	DE	DE	E	
Stabilizer Interlock Relay	DE	E	DE	E	
Stabilizer Lock-Up Relay	DE	DE	DE	E	
Extend Circuit Solenoid Valve	E	E	DE	E	
Park Brake Solenoid Valve	DE	DE	DE	DE	
Park Brake Interlock Relay	DE	DE	DE	E	

NOTE: If an outrigger is up or a pressure switch is defective, boom on 10054 will not extend beyond 42 series extension limit.

Definitions:

Boom Retracted = Less than 42 series extension limit

Boom Extended = Boom at 42 series extension limit or greater (See Figure)

PB = Park Brake

SB = Service Brake

DE = De-energized

E = Energized

C = Closed

O = Open

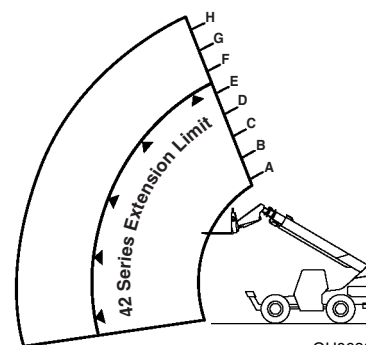

OH0630

SECTION 10

10054 Stabil-TRAK Electrical Circuit Boom Extend Mode 1 (S/N 9908 & Before)

MODE 1	1.	4.
Conditions	2.	5.
	3.	6.
	Ignition "ON"	Transmission in Fwd. or Rev.
	Boom Below 40°	PB & SB Released
	Boom Retracted	Outriggers Up

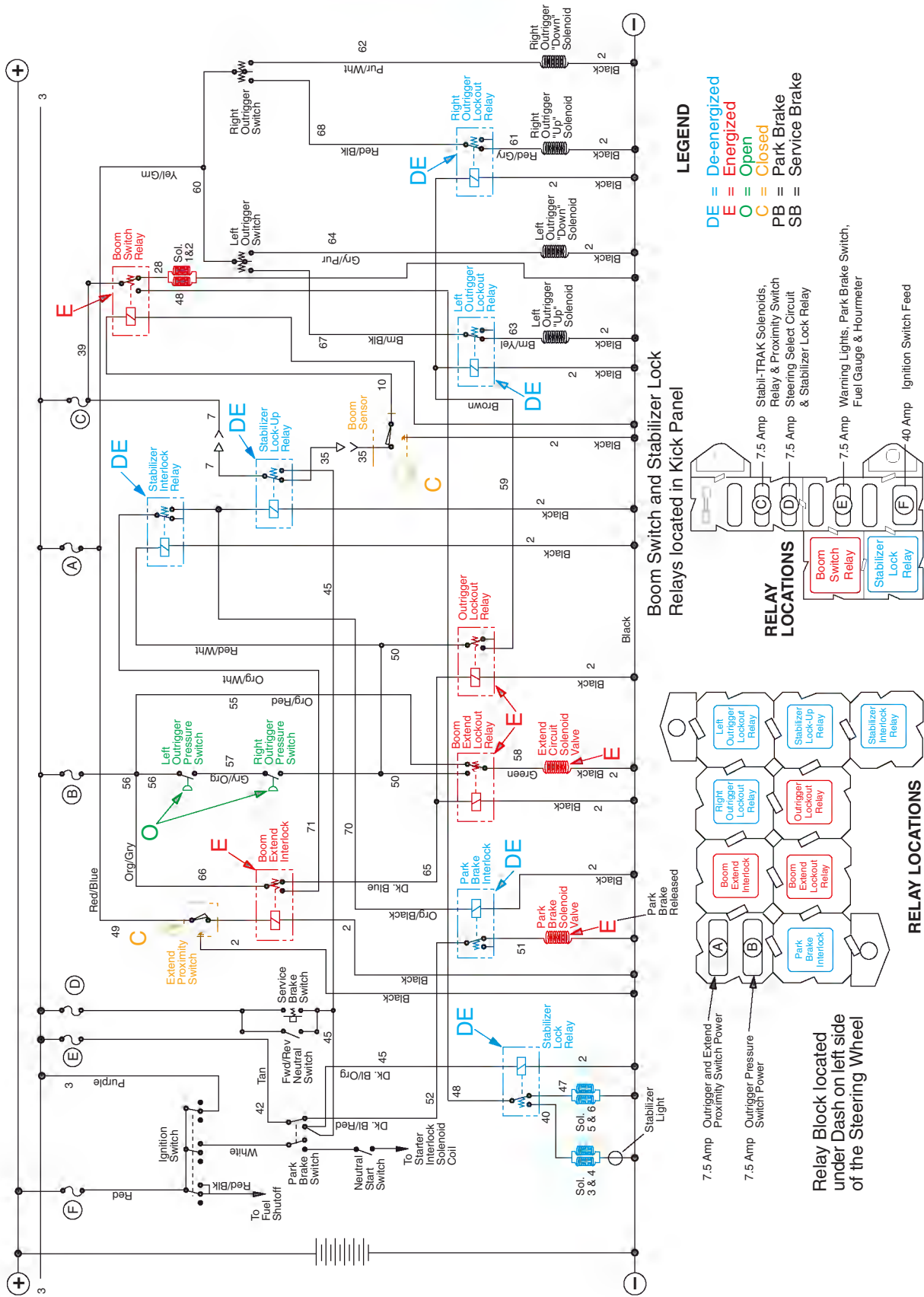

LEGEND

- DE = De-energized
- E = Energized
- O = Open
- C = Closed
- PB = Park Brake
- SB = Service Brake

Boom Switch and Stabilizer Lock Relays located in Kick Panel

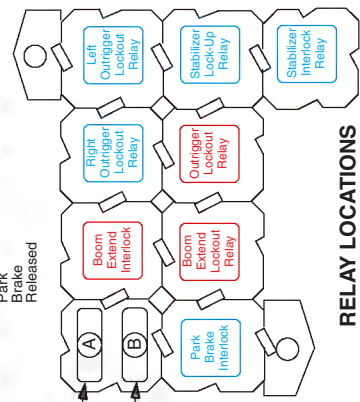

RELAY LOCATIONS

Relay Block located under Dash on left side of the Steering Wheel

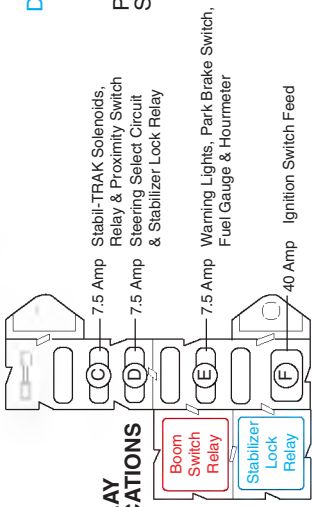

RELAY LOCATIONS

10054 Stabil-TRAK Electrical Circuit
 Boom Extend Mode 2
 (S/N 9908 & Before)

MODE 2	1.	2.	3.	4.	5.	6.
Conditions	Ignition "ON"	Boom Below 40°	Boom Extended	Transmission in Fwd. or Rev.	PB & SB Released	Outriggers Up

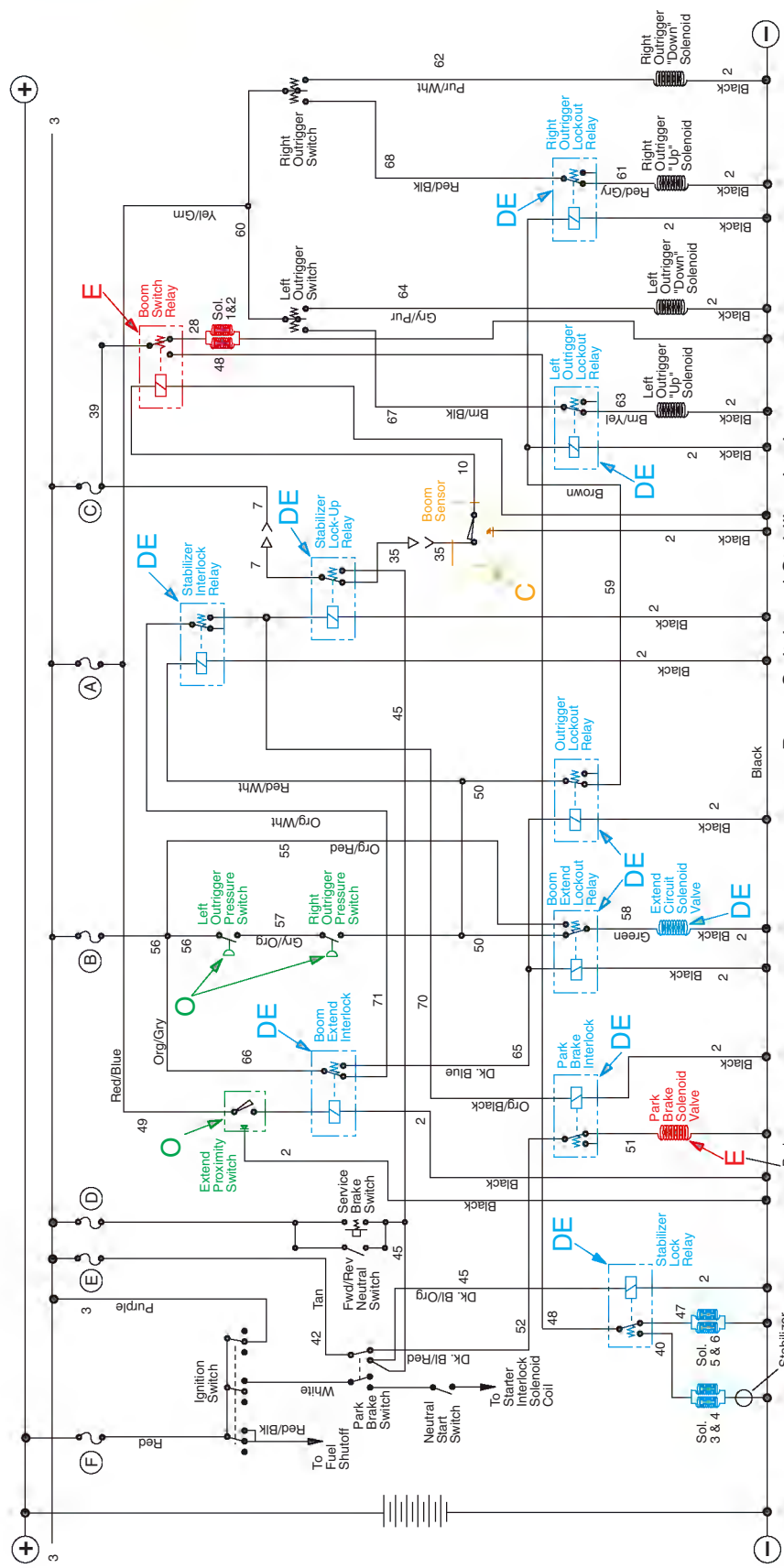

LEGEND

- DE = De-energized
- E = Energized
- O = Open
- C = Closed
- PB = Park Brake
- SB = Service Brake

Boom Switch and Stabilizer Lock
 Relays located in Kick Panel

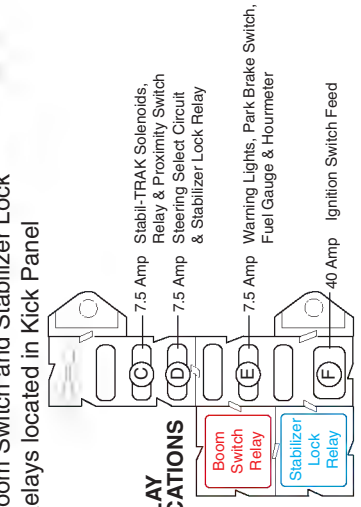

RELAY LOCATIONS

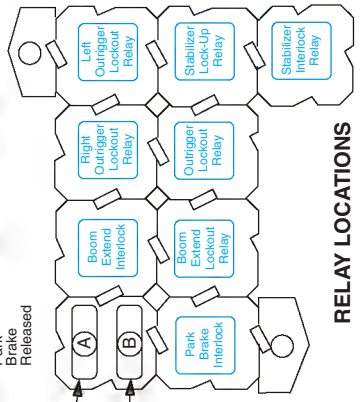

RELAY LOCATIONS

7.5 Amp Outrigger and Extend Proximity Switch Power
 7.5 Amp Outrigger Pressure Switch Power
 Relay Block located under Dash on left side of the Steering Wheel

SECTION 10

10054 Stabil-TRAK Electrical Circuit Boom Extend Mode 3 (S/N 9908 & Before)

MODE 3	1.	4.
Conditions	2.	5.
	3.	6.
	Ignition "ON"	Transmission in Neutral
	Boom Below 40°	PB & SB Applied
	Boom Extended	Outriggers Down

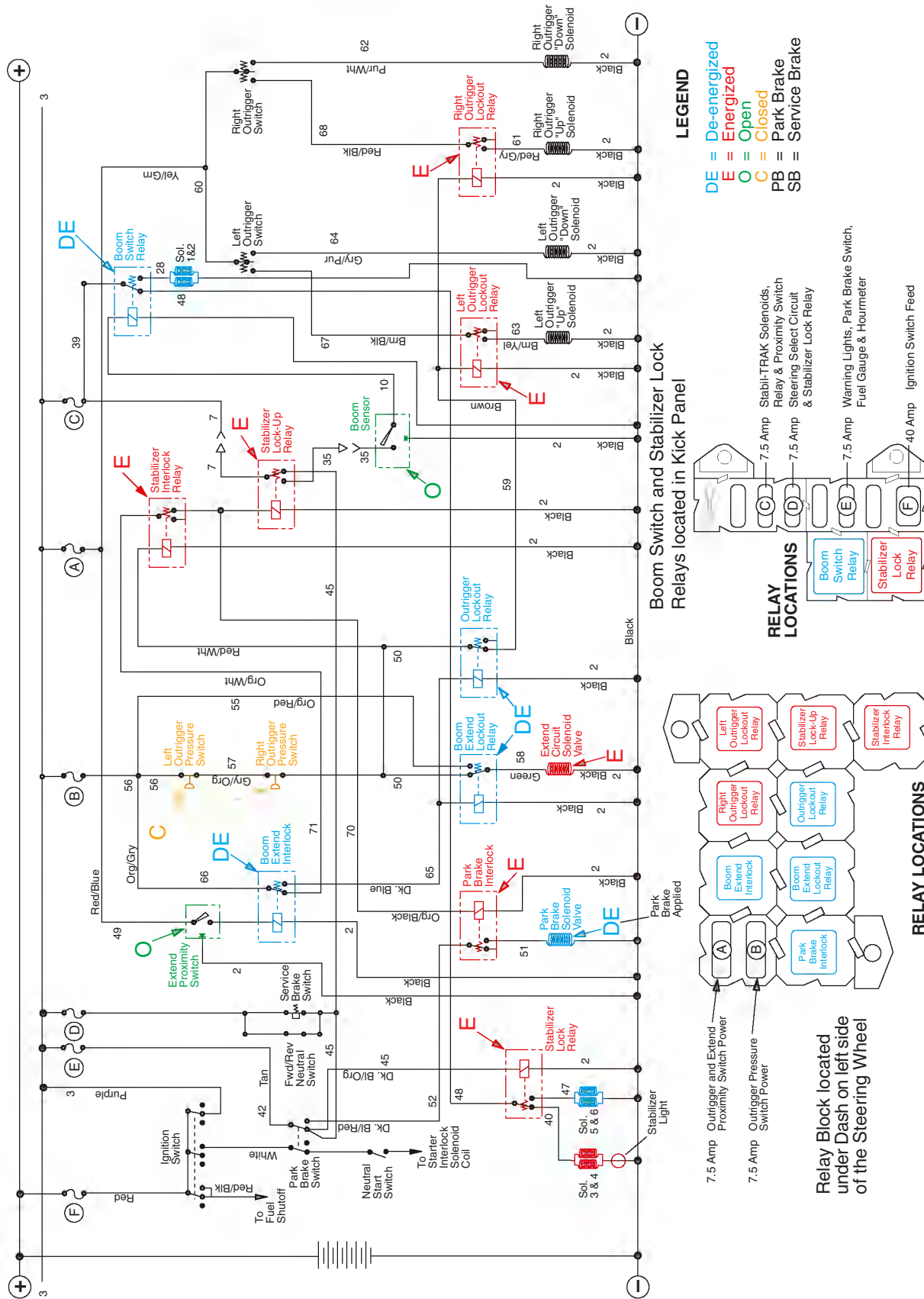

LEGEND

DE	= De-energized
E	= Energized
O	= Open
C	= Closed
PB	= Park Brake
SB	= Service Brake

Boom Switch and Stabilizer Lock Relays located in Kick Panel

RELAY LOCATIONS

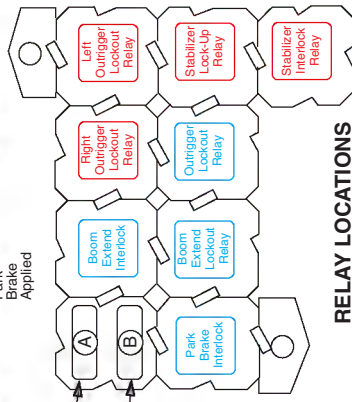

Relay Block located under Dash on left side of the Steering Wheel

RELAY LOCATIONS

MODE 4	1.	2.	3.	4.	5.	6.
Conditions	Ignition "ON"	Boom Above 40°	Boom Retracted	Transmission in Fwd. or Rev.	PB & SB Released	Outriggers Up

**10054 Stabil-TRAK Electrical Circuit
Boom Extend Mode 4
(S/N 9908 & Before)**

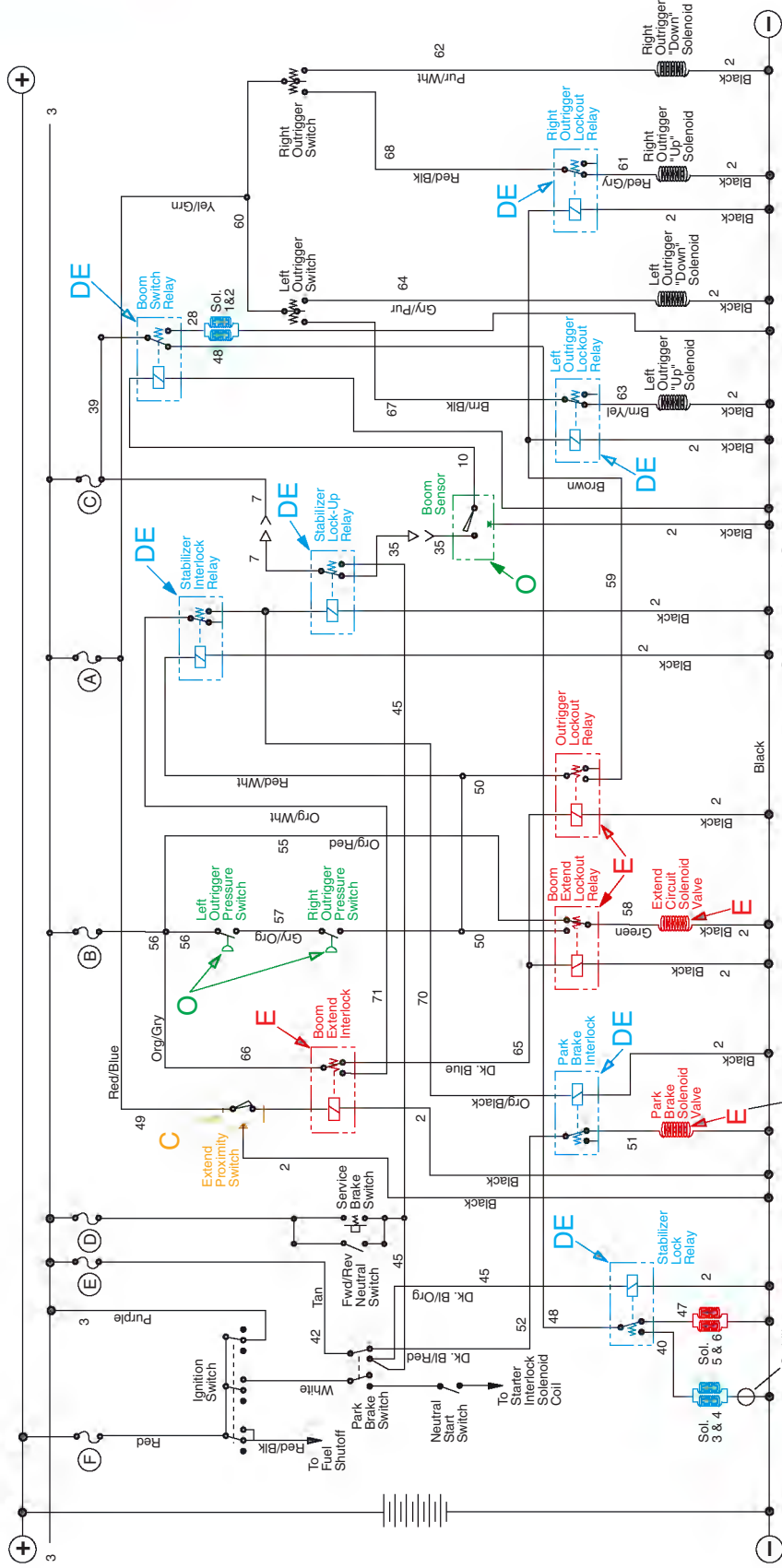

LEGEND

- DE = De-energized
- E = Energized
- O = Open
- C = Closed
- PB = Park Brake
- SB = Service Brake

Boom Switch and Stabilizer Lock Relays located in Kick Panel

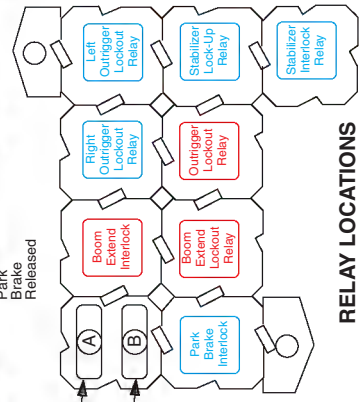

RELAY LOCATIONS

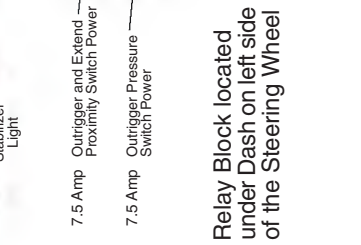

Relay Block located under Dash on left side of the Steering Wheel

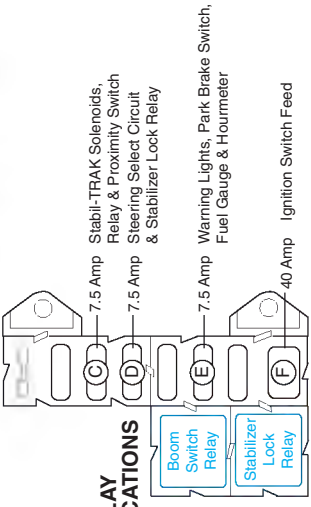

RELAY LOCATIONS

SECTION 10

10054 Stabil-TRAK Electrical Circuit
 Boom Extend Mode 5
 (S/N 9908 & Before)

MODE 5	1.	4.	
Conditions	2.	5.	6.
	3.		

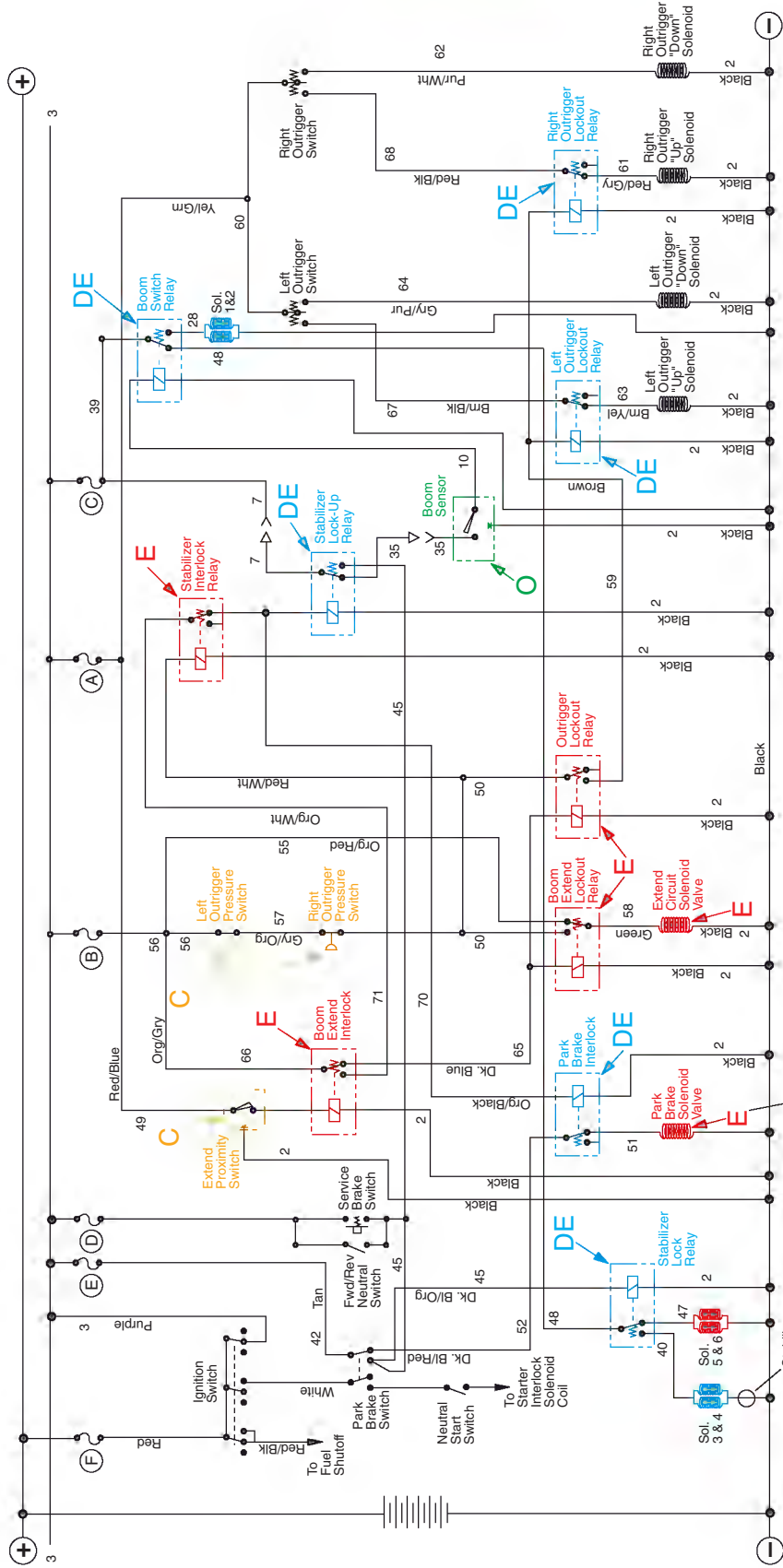

- LEGEND**
- DE = De-energized
 - E = Energized
 - O = Open
 - C = Closed
 - PB = Park Brake
 - SB = Service Brake

Boom Switch and Stabilizer Lock Relays located in Kick Panel

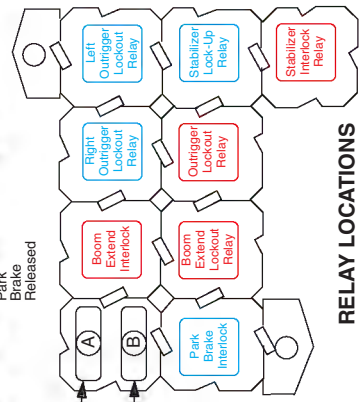

RELAY LOCATIONS

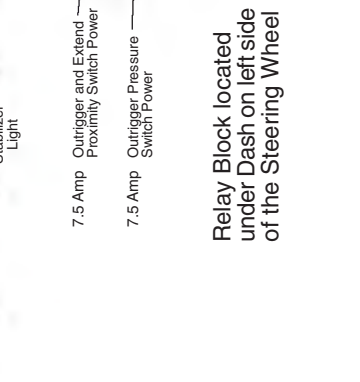

Relay Block located under Dash on left side of the Steering Wheel

RELAY LOCATIONS

MODE 6	1.	2.	3.	4.	5.	6.
Conditions	Ignition "ON"	Boom Above 40°	Boom Retracted	Transmission in Neutral	PB & SB Applied	Outriggers Up

**10054 Stabil-TRAK Electrical Circuit
Boom Extend Mode 6
(S/N 9908 & Before)**

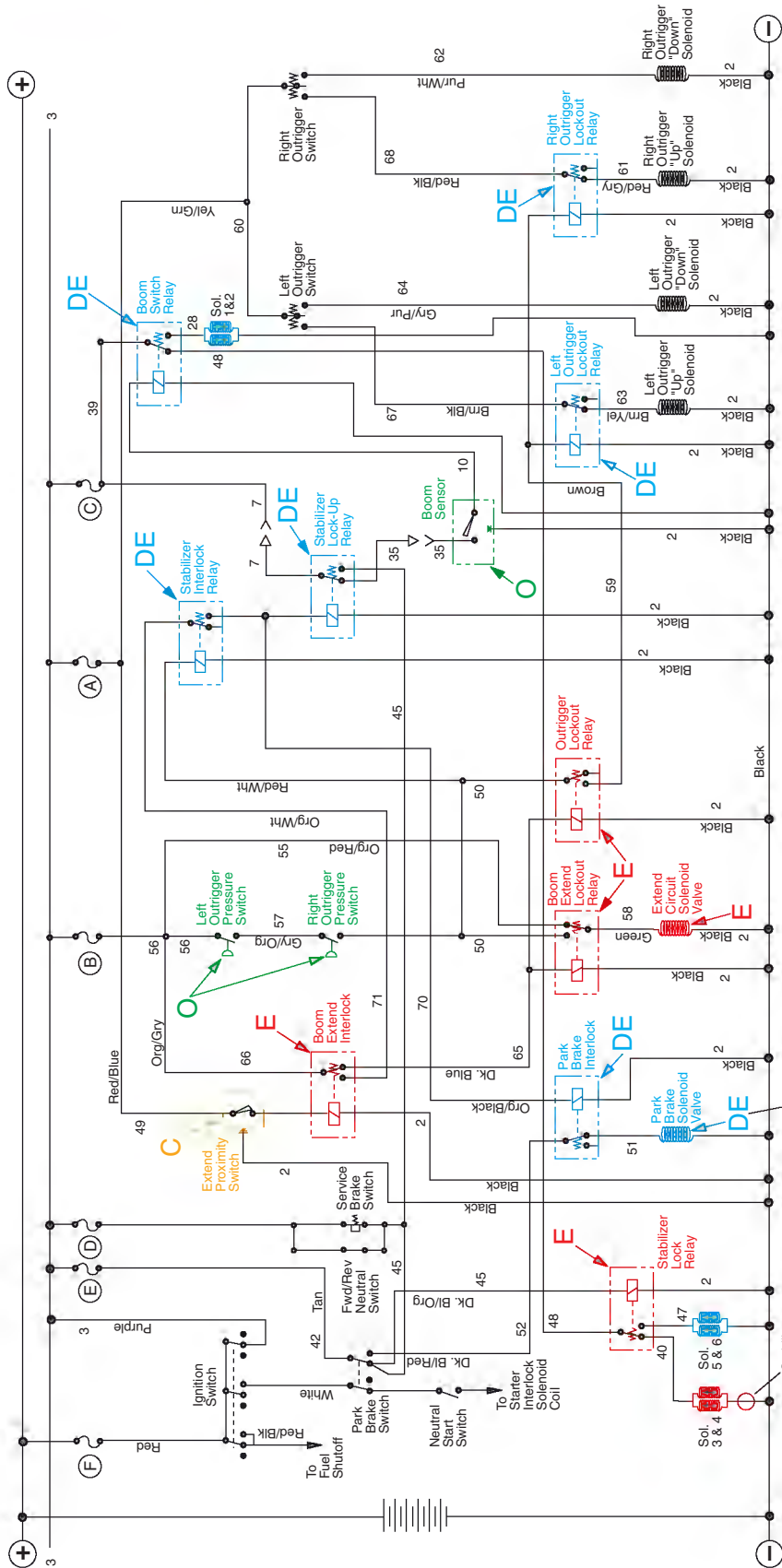

LEGEND

- DE = De-energized
- E = Energized
- O = Open
- C = Closed
- PB = Park Brake
- SB = Service Brake

**Boom Switch and Stabilizer Lock
Relays located in Kick Panel**

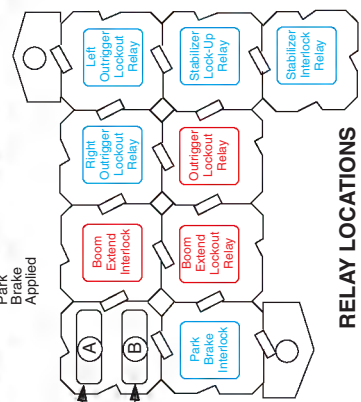
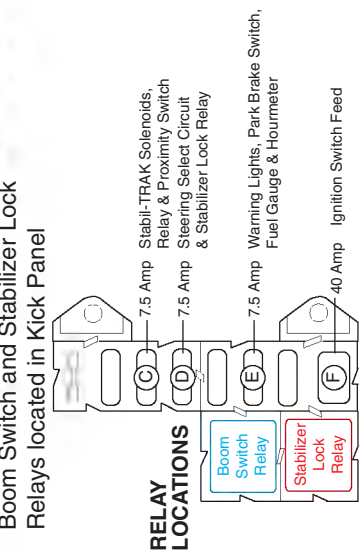

**Relay Block located
under Dash on left side
of the Steering Wheel**

SECTION 10

10054 Stabil-TRAK Electrical Circuit
Boom Extend Mode 7
(S/N 9908 & Before)

MODE 7	1.	2.	3.	4.	5.	6.
Conditions	Ignition "ON"	Boom Above 40°	Boom Retracted	Transmission in Neutral	PB & SB Applied	Outriggers Down

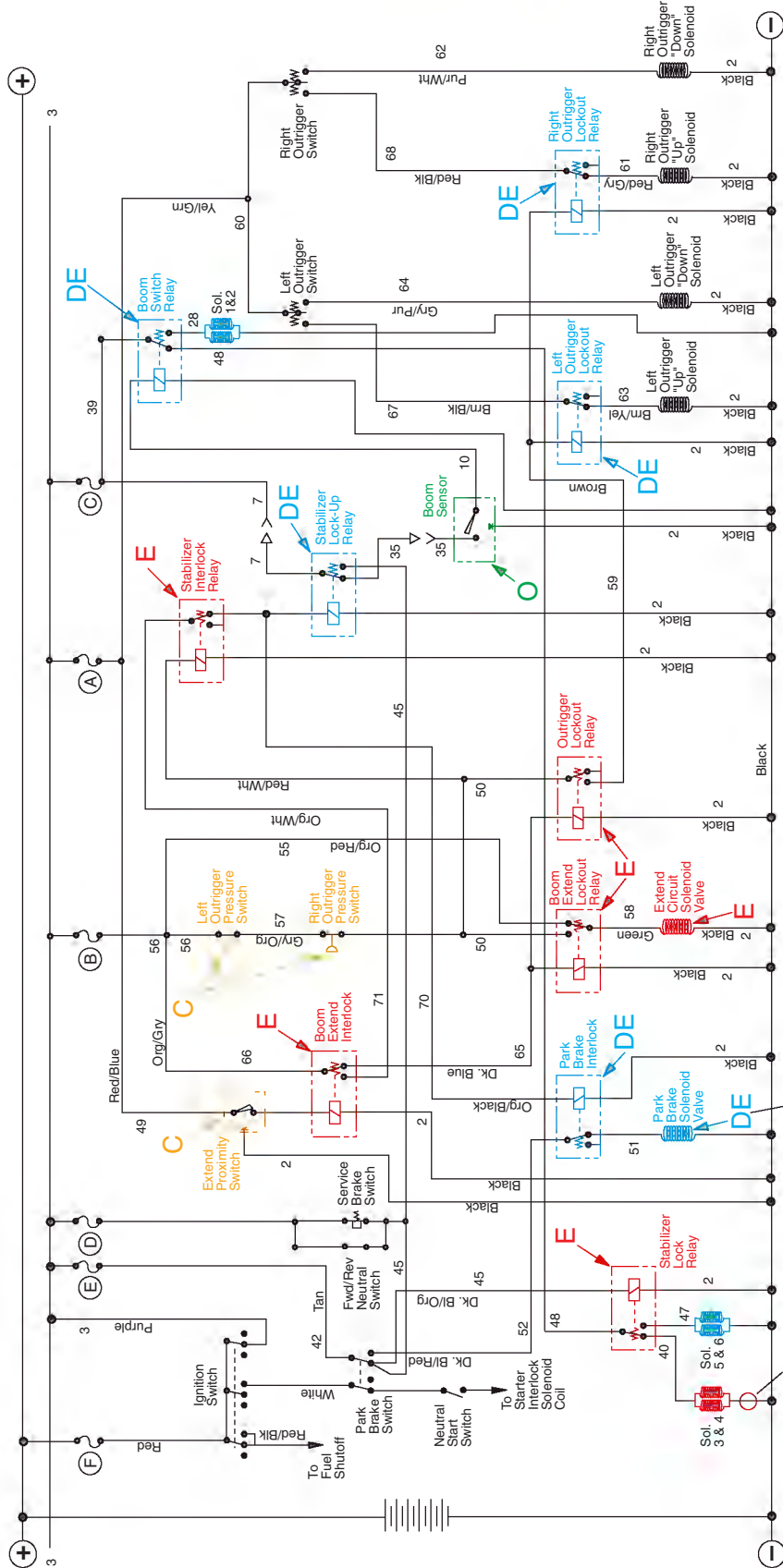

LEGEND

- DE = De-energized
- E = Energized
- O = Open
- C = Closed
- PB = Park Brake
- SB = Service Brake

Boom Switch and Stabilizer Lock Relays located in Kick Panel

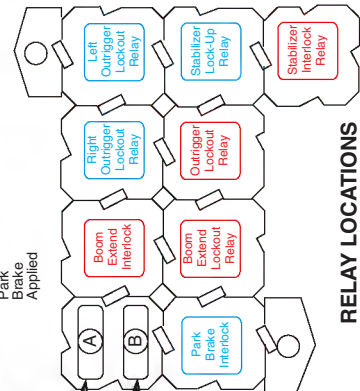
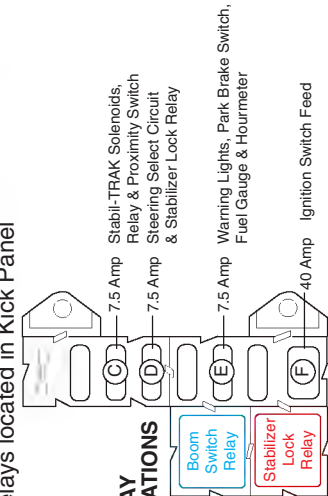

Relay Block located under Dash on left side of the Steering Wheel

RELAY LOCATIONS

MODE 8	1.	2.	3.	4.	5.	6.
Conditions	1.	Ignition "ON"		4.	Transmission in Neutral	
	2.	Boom Above 40°		5.	PB & SB Applied	
	3.	Boom Extended		6.	Outriggers Up	

**10054 Stabil-TRAK Electrical Circuit
Boom Extend Mode 8
(S/N 9908 & Before)**

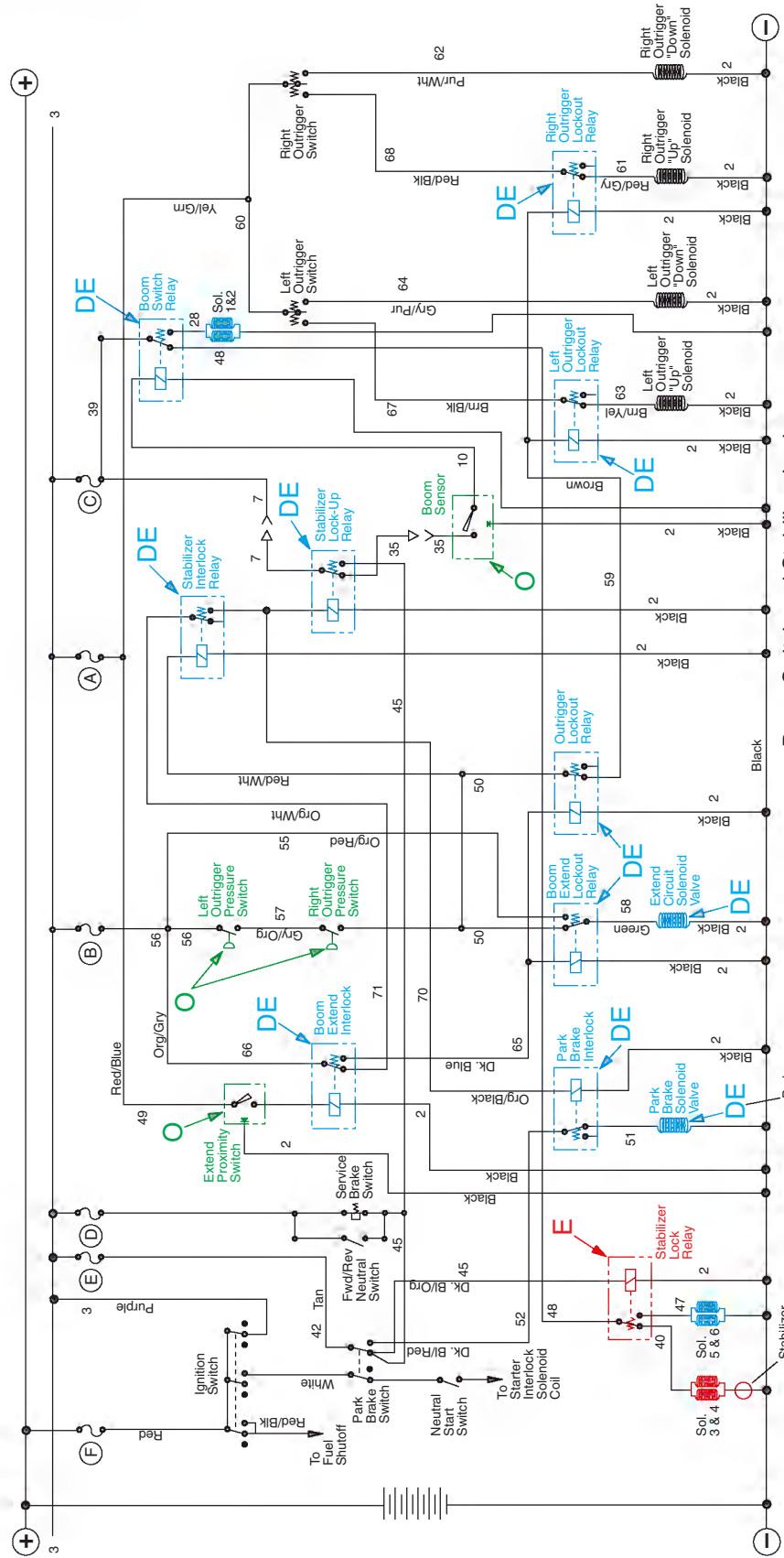

LEGEND

- DE = De-energized
- E = Energized
- O = Open
- C = Closed
- PB = Park Brake
- SB = Service Brake

Boom Switch and Stabilizer Lock
Relays located in Kick Panel

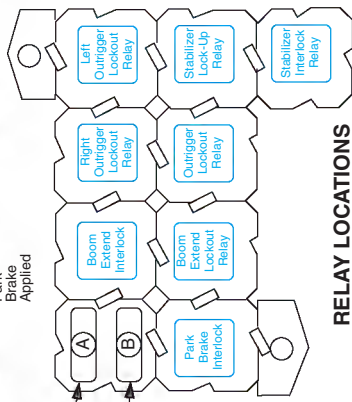
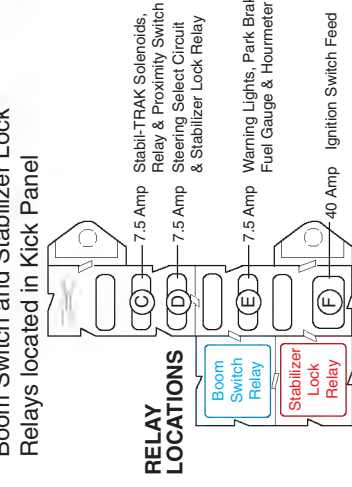

Relay Block located under Dash on left side of the Steering Wheel

SECTION 10

10054 Stabil-TRAK Electrical Circuit
Boom Extend Mode 9
(S/N 9908 & Before)

MODE 9	1.	4.
Conditions	2.	5.
	3.	6.
	Ignition "ON"	Transmission in Neutral
	Boom Above 40°	PB & SB Applied
	Boom Extended	Outriggers Down

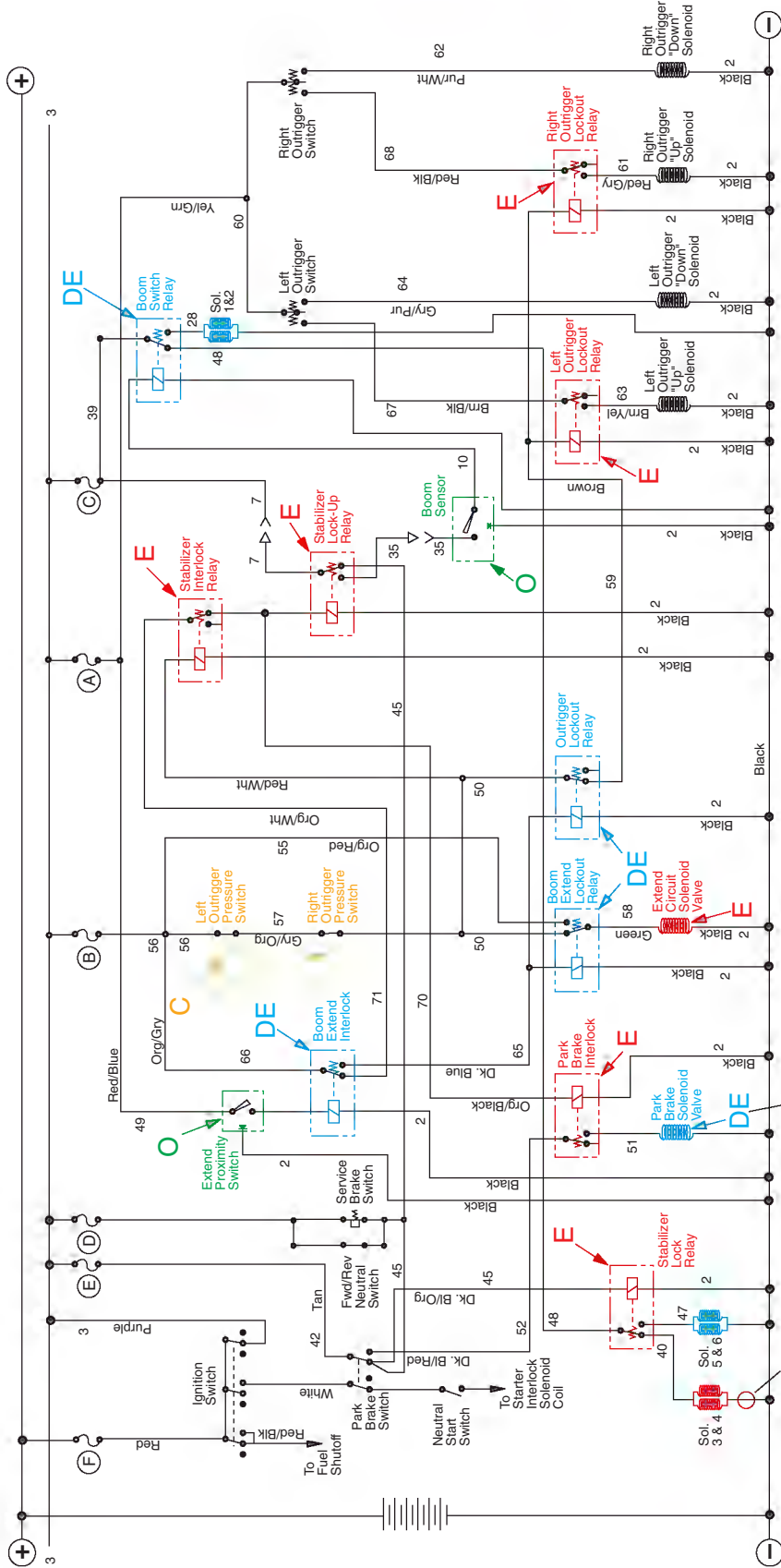

LEGEND
 DE = De-energized
 E = Energized
 O = Open
 C = Closed
 PB = Park Brake
 SB = Service Brake

Boom Switch and Stabilizer Lock Relays located in Kick Panel

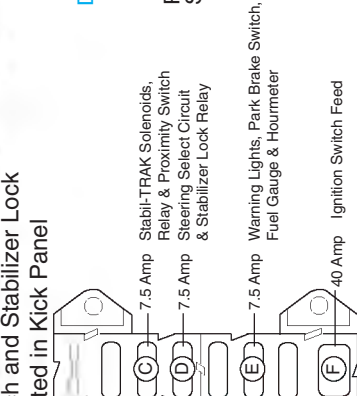

RELAY LOCATIONS

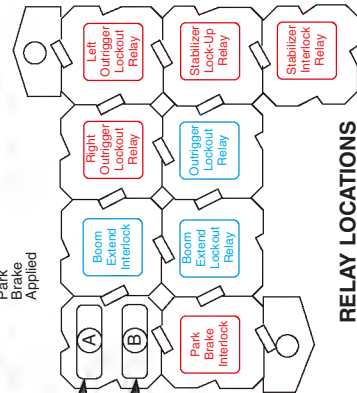

RELAY LOCATIONS

Relay Block located under Dash on left side of the Steering Wheel

7.5 Amp Outrigger and Extend Proximity Switch Power
 7.5 Amp Outrigger Pressure Switch Power

NOTES

SECTION 10

10054 Stabil-TRAK System Troubleshooting (S/N 9909 & After)

	BOOM EXTEND MODE 1	BOOM EXTEND MODE 2	BOOM EXTEND MODE 3	BOOM EXTEND MODE 4	BOOM EXTEND MODE 5
	Reference page 398	Reference page 399	Reference page 400	Reference page 401	Reference page 402
Machine Conditions	Ignition On Boom Below 40° Boom Retracted PB & SB Released Trans. Fwd. or Rev. Outriggers Up	Ignition On Boom Below 40° Boom Extended PB & SB Released Trans. Fwd. or Rev. Outriggers Up	Ignition On Boom Below 40° Boom Extended PB & SB Applied Trans. Neutral Outriggers Down	Ignition On Boom Above 40° Boom Retracted PB & SB Released Trans. Fwd. or Rev. Outriggers Up	Ignition On Boom Above 40° Boom Retracted PB & SB Released Trans. Fwd. or Rev. Outriggers Down
Switch/Relay/Solenoid					
Solenoid 1	E	E	E	DE	DE
Solenoid 2	E	E	E	DE	DE
Solenoid 3	DE	DE	DE	DE	DE
Solenoid 4	DE	DE	DE	DE	DE
Solenoid 5	DE	DE	DE	E	E
Solenoid 6	DE	DE	DE	E	E
Boom Angle Sensor	C	C	O	O	O
Boom Relay	E	E	E	DE	DE
Stabilizer Lock Relay	DE	DE	E	DE	DE
Stabilizer Light	Off	Off	On	Off	On

BOOM EXTEND INTERLOCK SYSTEM TROUBLESHOOTING

Boom Extend Proximity Switch	C	O	O	C	C
Boom Extend Interlock Relay	E	DE	DE	E	E
Boom Extend Lockout Relay	E	DE	DE	E	E
Outrigger Lockout Relay	E	DE	DE	E	E
Outrigger Pressure Switches	O	O	C	O	C
Left Outrigger Lockout Relay	DE	DE	E	DE	DE
Right Outrigger Lockout Relay	DE	DE	E	DE	DE
Stabilizer Interlock Relay	DE	DE	E	DE	E
Stabilizer Lock-Up Relay	DE	DE	E	DE	DE
Extend Circuit Solenoid Valve	E	DE	E	E	E
Park Brake Solenoid Valve	E	E	DE	E	E
Park Brake Interlock Relay	DE	DE	E	DE	DE
Park Brake Disconnect Relay	E	E	DE	E	E
Neutral Start Relay	DE	DE	E	DE	DE

NOTE: If an outrigger is up or a pressure switch is defective, boom on 10054 will not extend beyond 42 series extension limit.

Definitions:

- Boom Retracted = Less than 42 series extension limit
- Boom Extended = Boom at 42 series extension limit or greater (See Figure)
- PB = Park Brake
- SB = Service Brake
- DE = De-energized
- E = Energized
- C = Closed
- O = Open

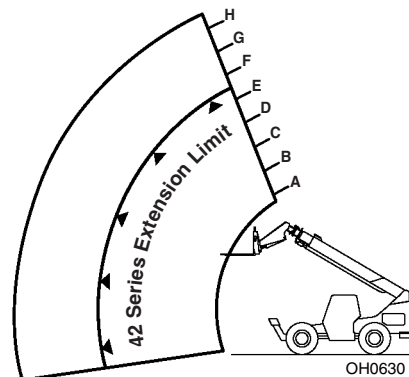

10054 Stabi-TRAK System Troubleshooting (S/N 9909 & After)

	BOOM EXTEND MODE 6	BOOM EXTEND MODE 7	BOOM EXTEND MODE 8	BOOM EXTEND MODE 9	
	Reference page 403	Reference page 404	Reference page 405	Reference page 406	
Switch/ Relay Solenoid					
Machine Conditions	Ignition On Boom Above 40° Boom Retracted PB & SB Applied Trans. Neutral Outriggers Up	Ignition On Boom Above 40° Boom Retracted PB & SB Applied Trans. Neutral Outriggers Down	Ignition On Boom Above 40° Boom Extended PB & SB Applied Trans. Neutral Outriggers Up	Ignition On Boom Above 40° Boom Extended PB & SB Applied Trans. Neutral Outriggers Down	
Solenoid 1	DE	DE	DE	DE	
Solenoid 2	DE	DE	DE	DE	
Solenoid 3	E	E	E	E	
Solenoid 4	E	E	E	E	
Solenoid 5	DE	DE	DE	DE	
Solenoid 6	DE	DE	DE	DE	
Boom Angle Sensor	O	O	O	O	
Boom Relay	DE	DE	DE	DE	
Stabilizer Lock Relay	E	E	E	E	
Stabilizer Light	On	On	On	On	
BOOM EXTEND INTERLOCK SYSTEM TROUBLESHOOTING					
Boom Extend Proximity Switch	C	C	O	O	
Boom Extend Interlock Relay	E	E	DE	DE	
Boom Extend Lockout Relay	E	E	DE	DE	
Outrigger Lockout Relay	E	E	DE	DE	
Outrigger Pressure Switches	O	C	O	C	
Left Outrigger Lockout Relay	DE	DE	DE	E	
Right Outrigger Lockout Relay	DE	DE	DE	E	
Stabilizer Interlock Relay	DE	E	DE	E	
Stabilizer Lock-Up Relay	DE	DE	DE	E	
Extend Circuit Solenoid Valve	E	E	DE	E	
Park Brake Solenoid Valve	DE	DE	DE	DE	
Park Brake Interlock Relay	DE	DE	DE	E	
Park Brake Disconnect Relay	DE	DE	DE	DE	
Neutral Start Relay	E	E	E	E	

NOTE: If an outrigger is up or a pressure switch is defective, boom on 10054 will not extend beyond 42 series extension limit.

Definitions:

Boom Retracted = Less than 42 series extension limit

Boom Extended = Boom at 42 series extension limit or greater (See Figure)

PB = Park Brake

SB = Service Brake

DE = De-energized

E = Energized

C = Closed

O = Open

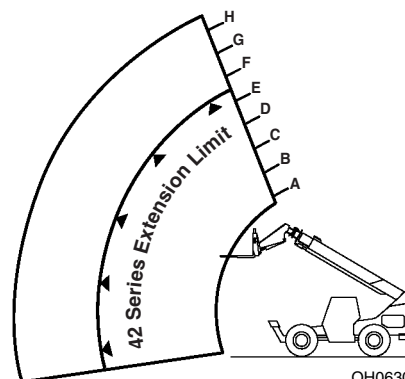

OH0630

SECTION 10

**10054 Stabil-TRAK Electrical Circuit
Boom Extend Mode 1
(S/N 9909 & After)**

MODE 1	1.	4.	
Conditions	2.	5.	6.
	Ignition "ON"	Boom Below 40°	Transmission in Fwd. or Rev.
	Boom Retracted	PB & SB Released	Outriggers Up

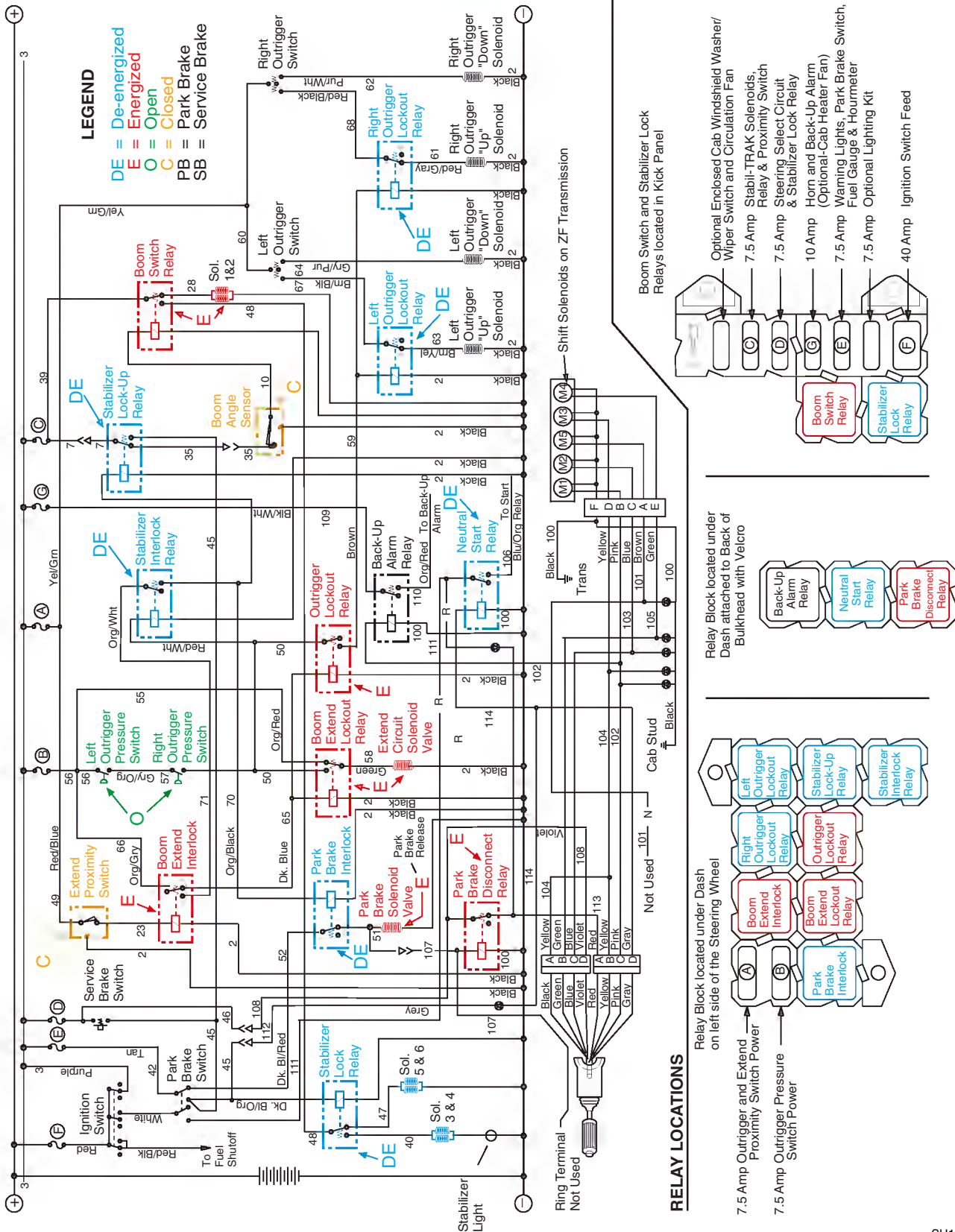

10054 Stabil-TRAK Electrical Circuit
 Boom Extend Mode 2
 (S/N 9909 & After)

MODE 2	1.	2.	3.	4.	5.	6.
Conditions	Ignition "ON"	Boom Below 40°	Boom Extended	Transmission in Fwd. or Rev.	PB & SB Released	Outriggers Up

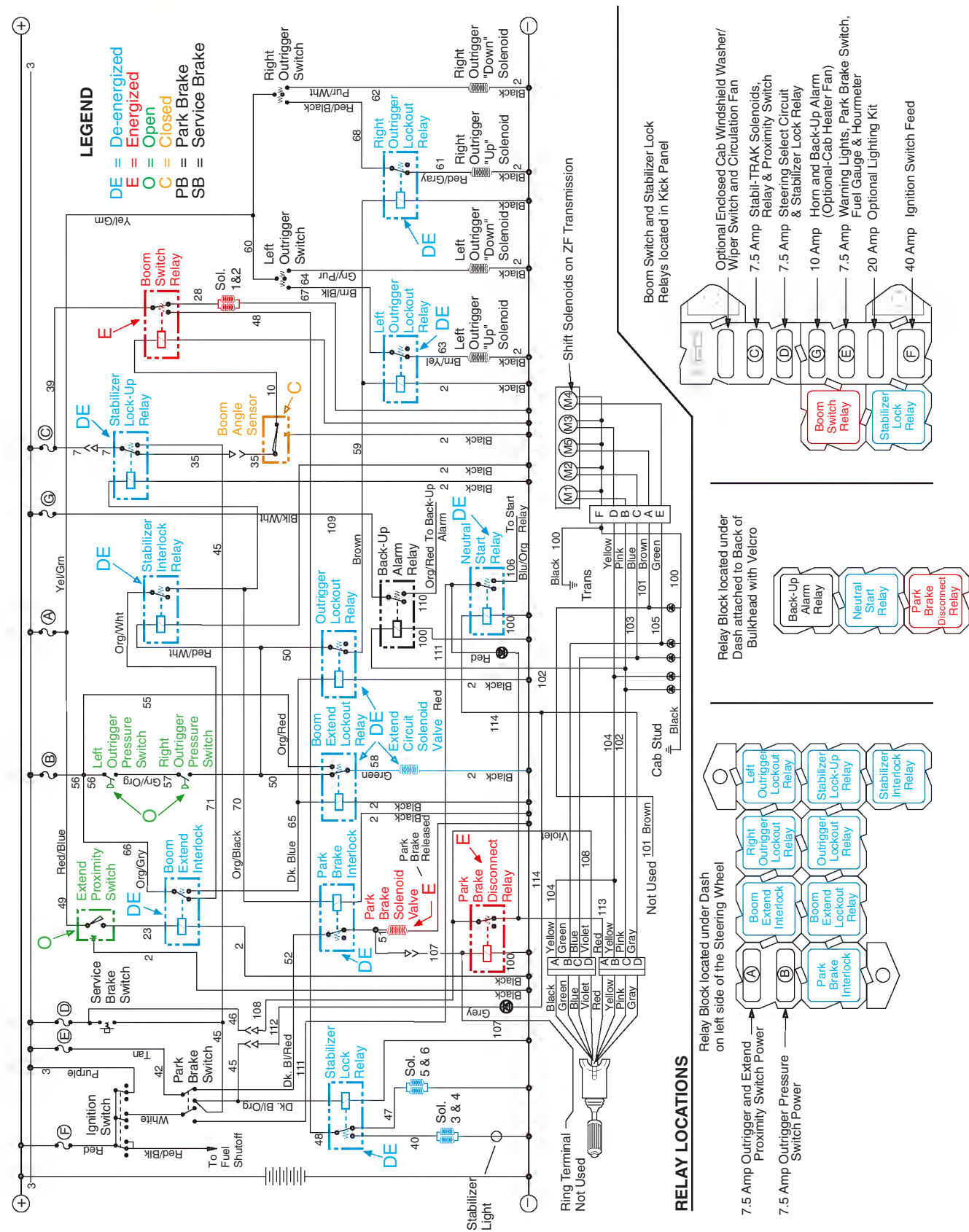

SECTION 10

**10054 Stabil-TRAK Electrical Circuit
Boom Extend Mode 3
(S/N 9909 & After)**

MODE 3	
Conditions	1. Ignition "ON"
	2. Boom Below 40°
	3. Boom Extended
	4. Transmission in Neutral
	5. PB & SB Applied
	6. Outriggers Down

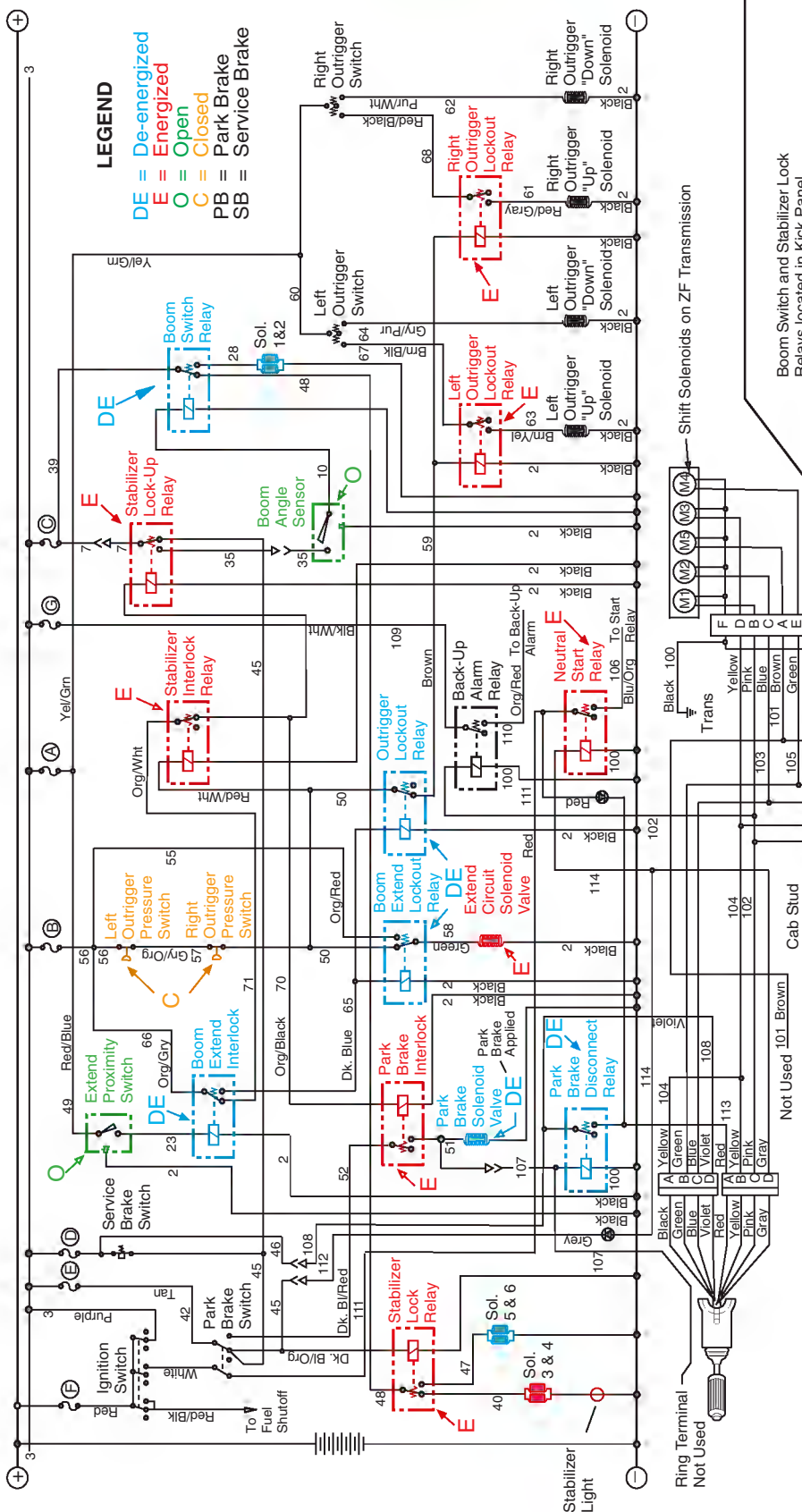

LEGEND

DE = De-energized
 E = Energized
 O = Open
 C = Closed
 PB = Park Brake
 SB = Service Brake

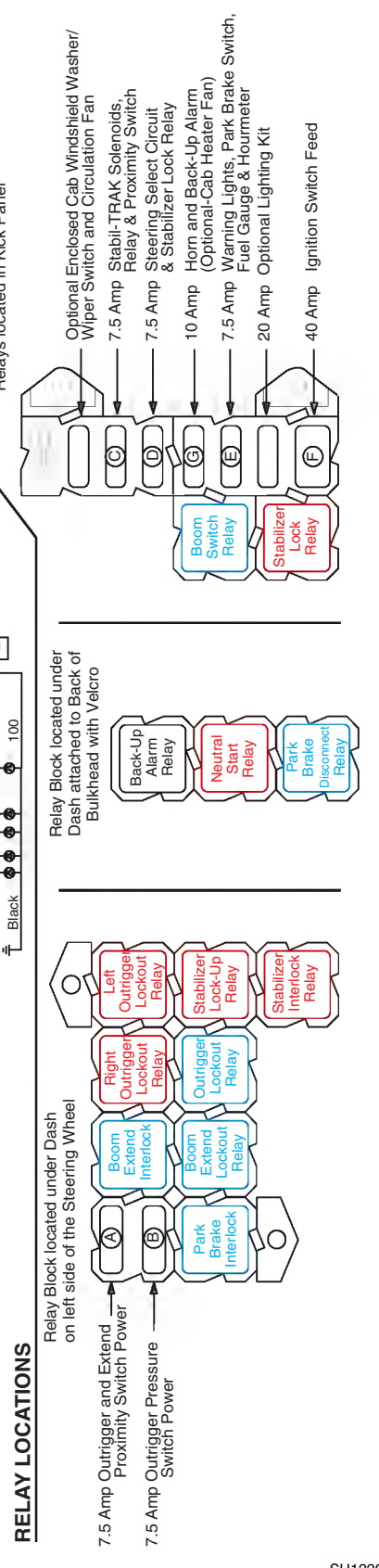

MODE 4	1.	2.	3.	4.	5.	6.
Conditions	Ignition "ON"	Boom Above 40°	Boom Retracted	Transmission in Fwd. or Rev.	PB & SB Released	Outriggers Up

**10054 Stabil-TRAK Electrical Circuit
Boom Extend Mode 4
(S/N 9909 & After)**

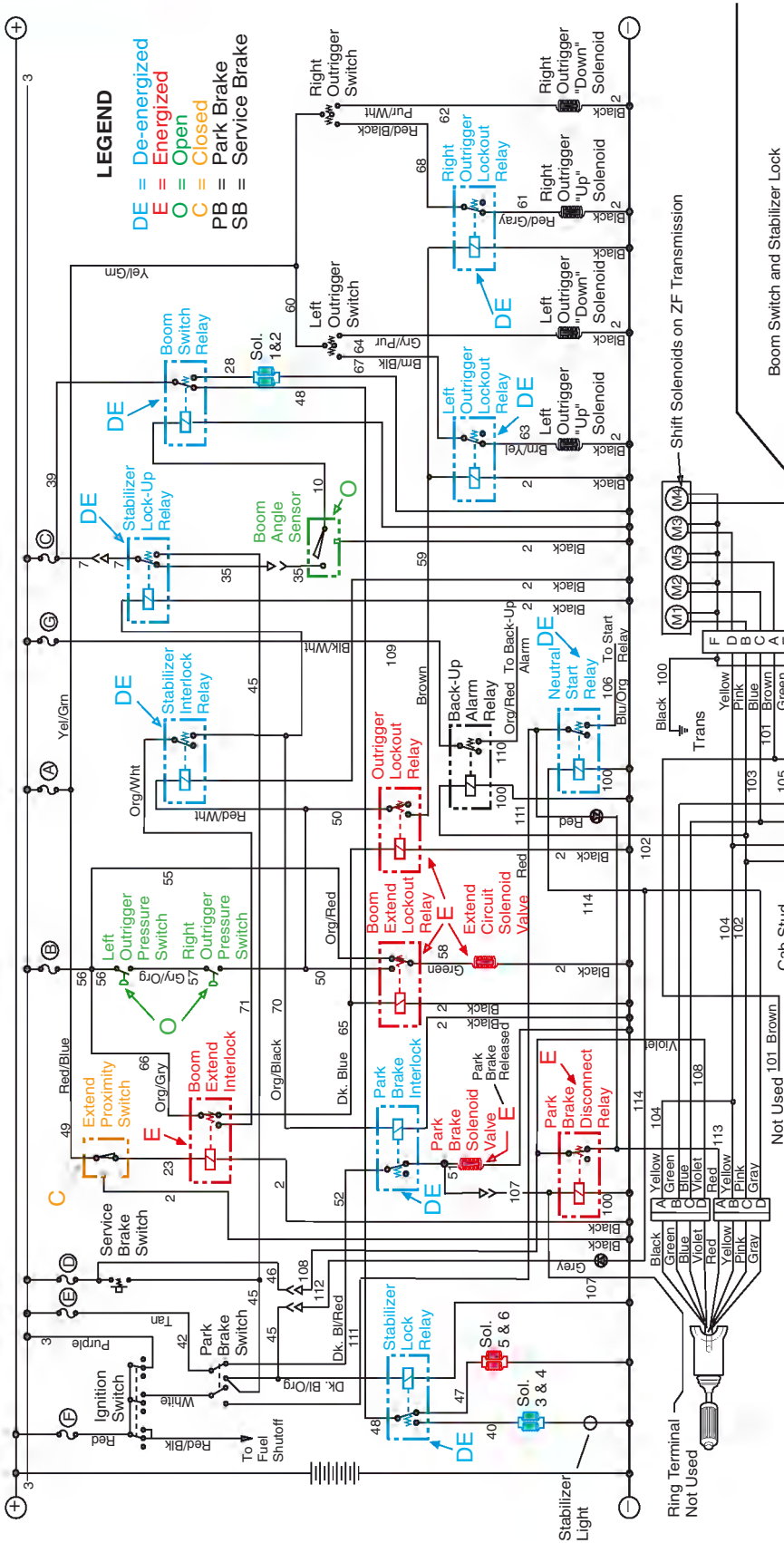

LEGEND
 DE = De-energized
 E = Energized
 O = Open
 C = Closed
 PB = Park Brake
 SB = Service Brake

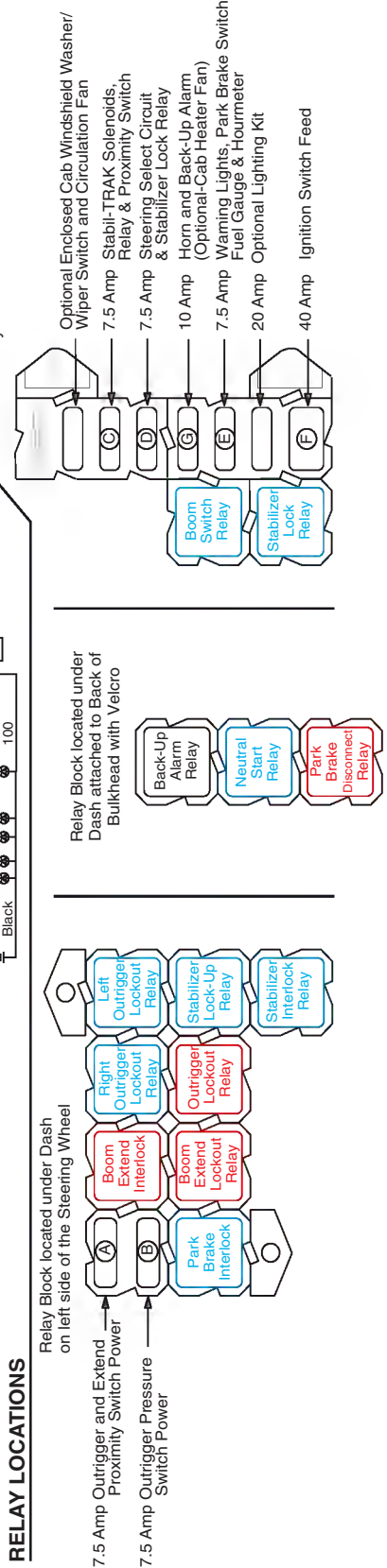

SECTION 10

10054 Stabil-TRAK Electrical Circuit
 Boom Extend Mode 5
 (S/N 9909 & After)

MODE 5	1.	4.	
Conditions	Ignition "ON"	Transmission in Fwd. or Rev.	
	Boom Above 40°	PB & SB Released	
	Boom Retracted	Outriggers Down	

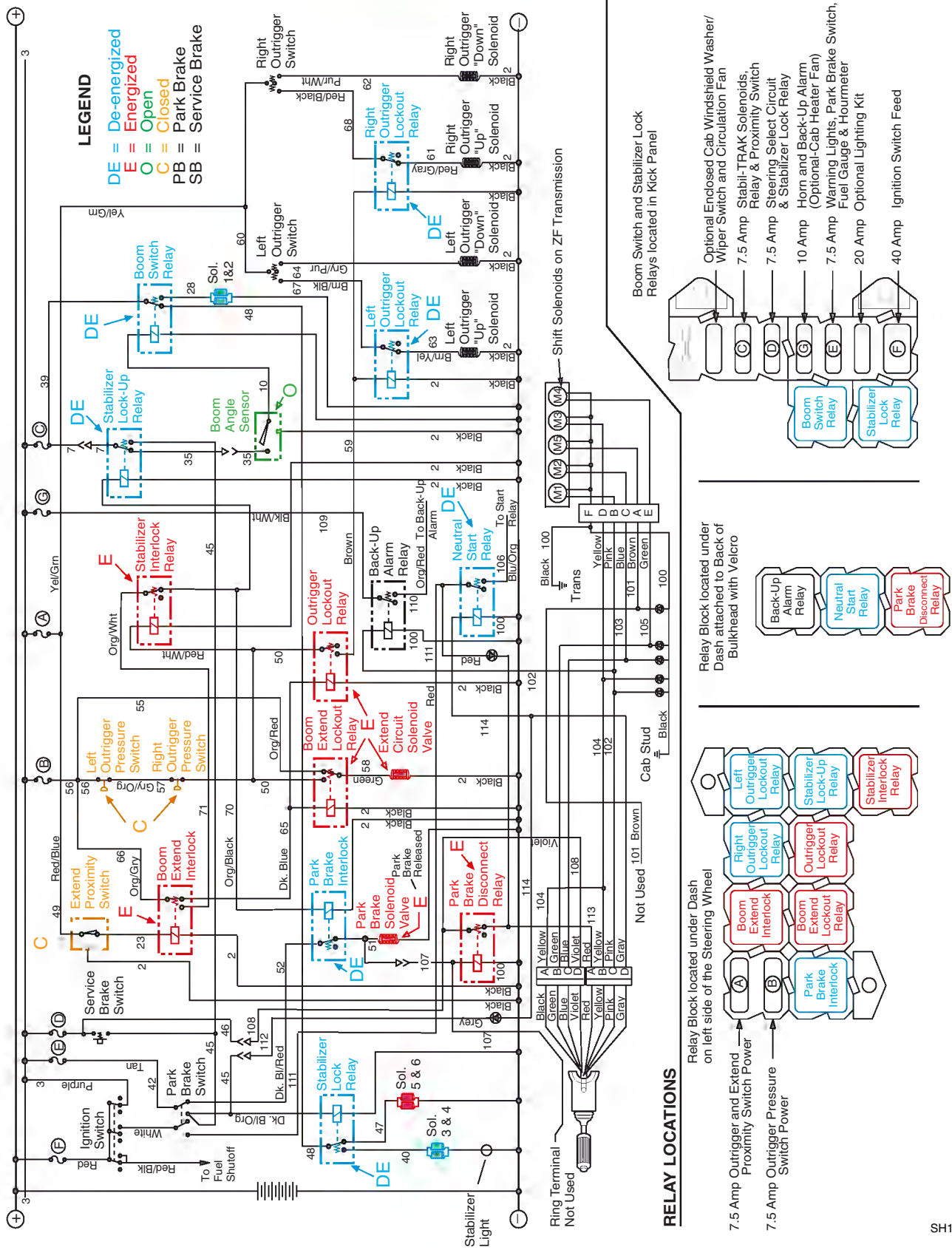

10054 Stabil-TRAK Electrical Circuit
 Boom Extend Mode 6
 (S/N 9909 & After)

MODE 6	1.	2.	3.	4.	5.	6.
Conditions	1.	Ignition "ON"	2.	Boom Above 40°	3.	Boom Retracted
	4.	Transmission in Neutral	5.	PB & SB Applied	6.	Outriggers Up

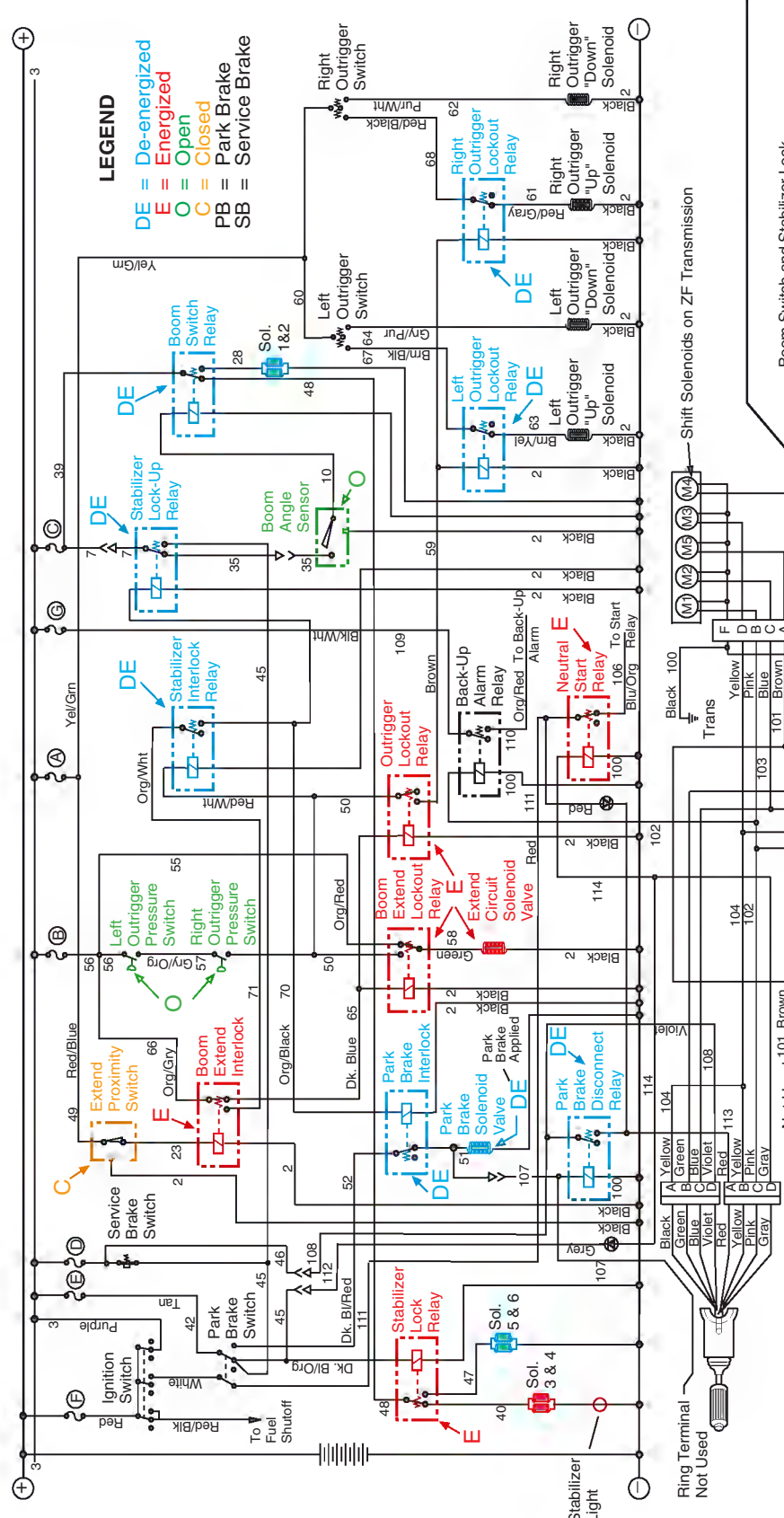

LEGEND
 DE = De-energized
 E = Energized
 O = Open
 C = Closed
 PB = Park Brake
 SB = Service Brake

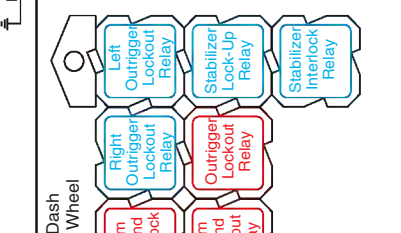
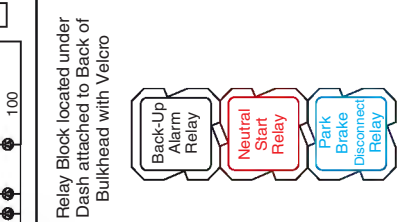
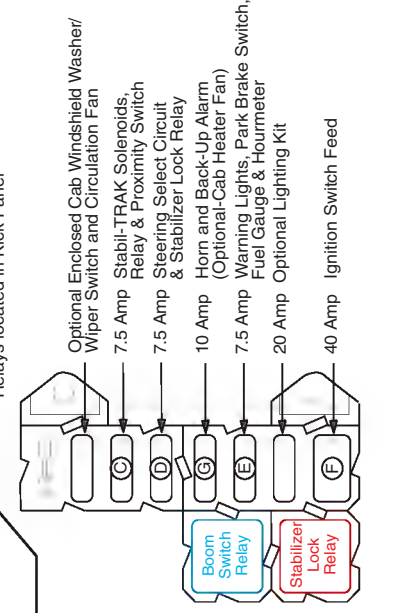

RELAY LOCATIONS

Relay Block located under Dash on left side of the Steering Wheel

7.5 Amp Outrigger and Extend Proximity Switch Power

7.5 Amp Outrigger Pressure Switch Power

Relay Block located under Dash attached to Back of Bulkhead with Velcro

Boom Switch and Stabilizer Lock Relays located in Kick Panel

Shift Solenoids on ZF Transmission

Not Used 101 Brown

SECTION 10

10054 Stabil-TRAK Electrical Circuit
Boom Extend Mode 7
(S/N 9909 & After)

MODE 7	1.	2.	3.	4.	5.	6.
Conditions	Ignition "ON"	Boom Above 40°	Boom Retracted	Transmission in Neutral	PB & SB Applied	Outriggers Down

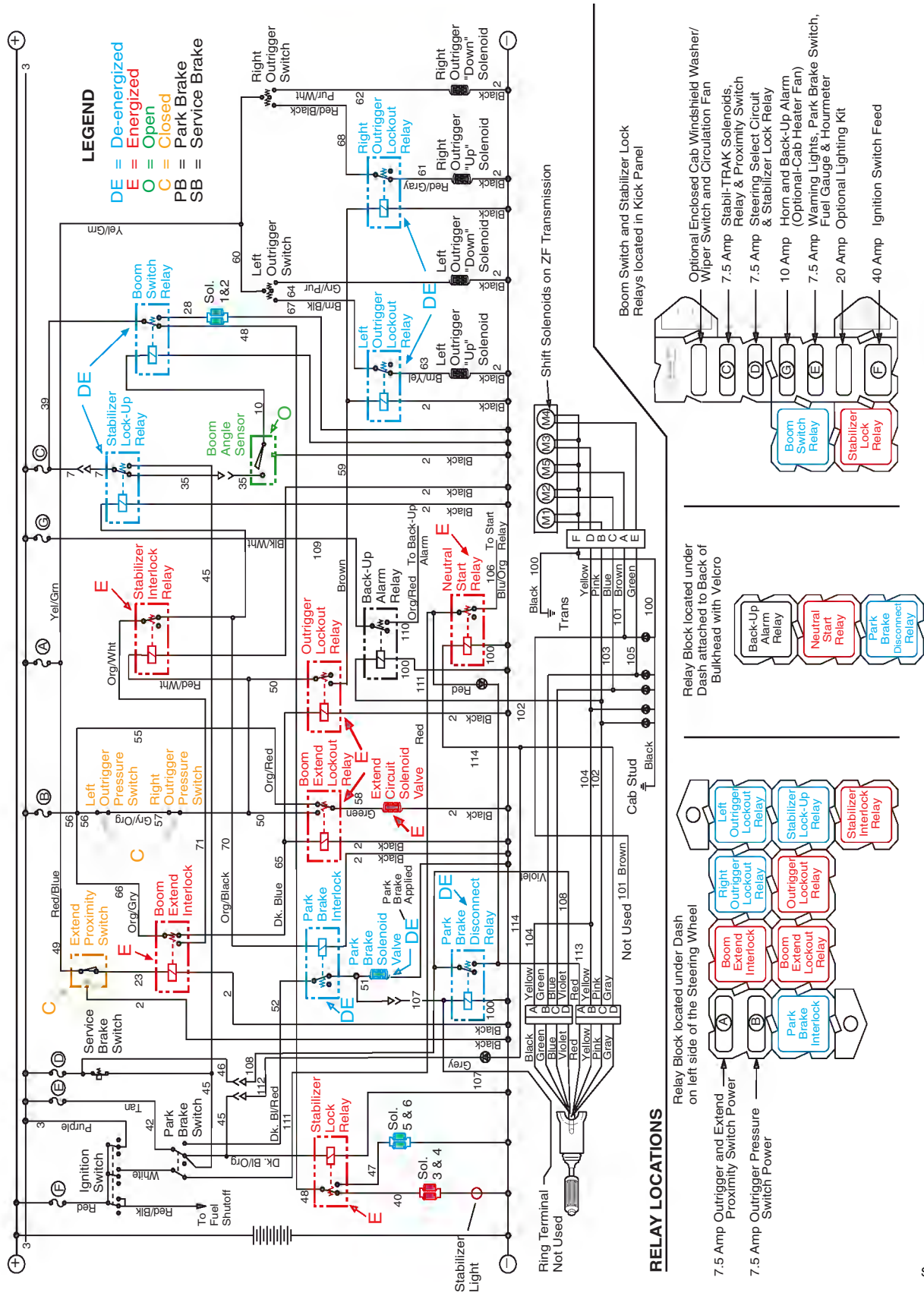

MODE 8	1.	2.	3.	4.	5.	6.
Conditions	Ignition "ON"	Boom Above 40°	Boom Extended	Transmission in Neutral	PB & SB Applied	Outriggers Up

**10054 Stabil-TRAK Electrical Circuit
Boom Extend Mode 8
(S/N 9909 & After)**

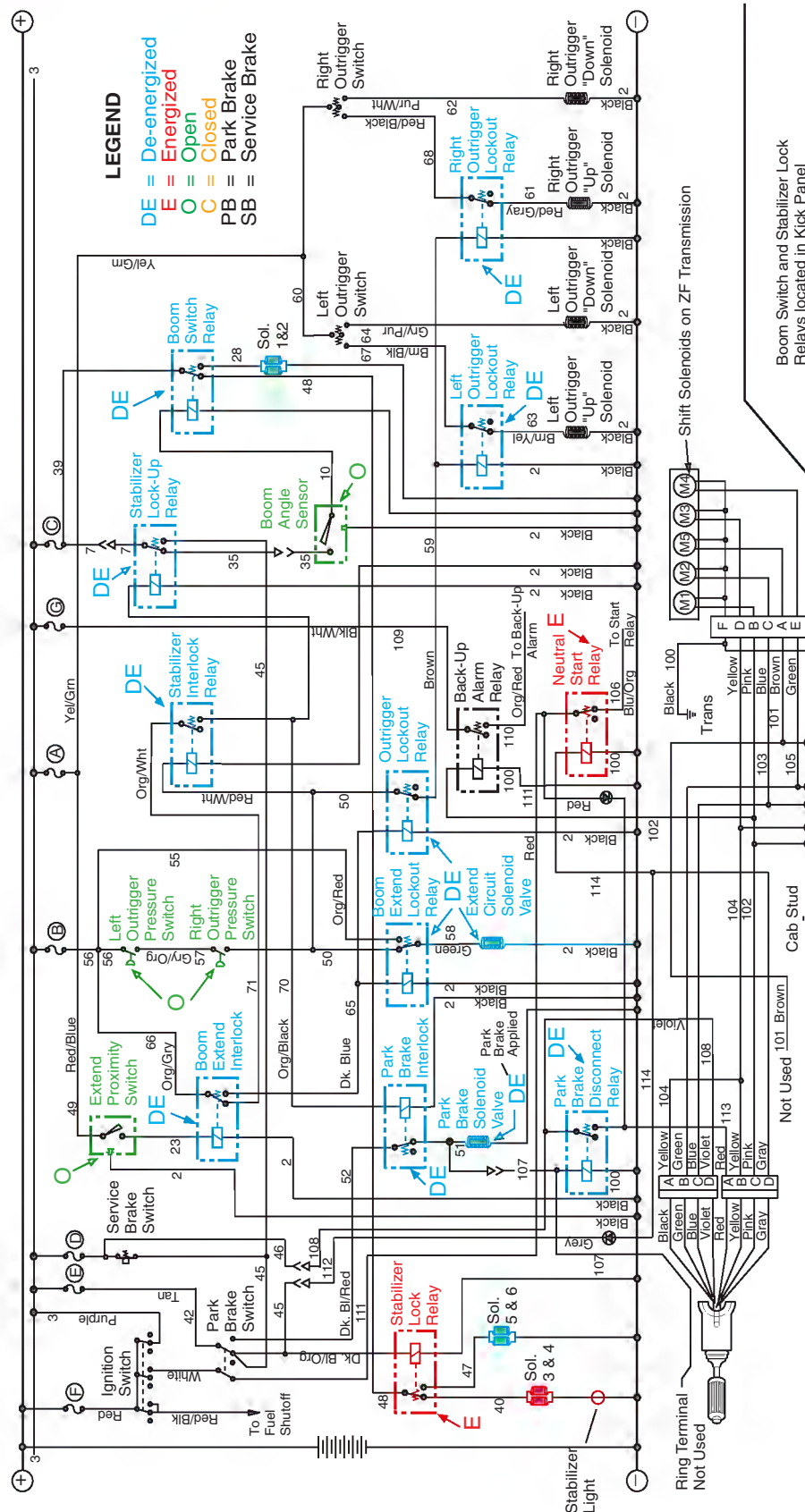

LEGEND
 DE = De-energized
 E = Energized
 O = Open
 C = Closed
 PB = Park Brake
 SB = Service Brake

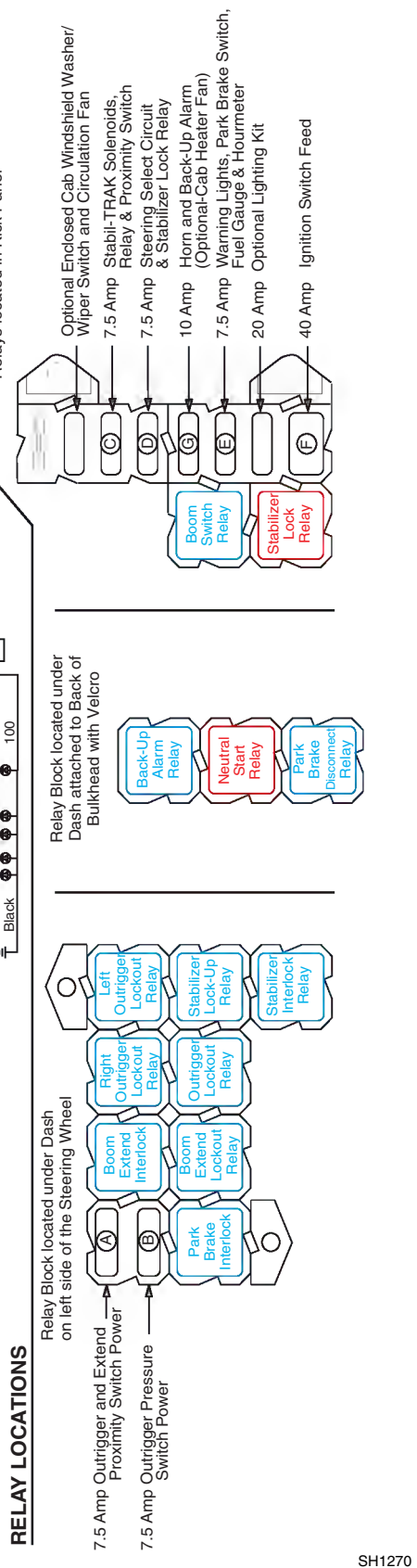

RELAY LOCATIONS

Relay Block located under the Dash on left side of the Steering Wheel

7.5 Amp Outrigger and Extend Proximity Switch Power

7.5 Amp Outrigger Pressure Switch Power

Relay Block located under Dash attached to Back of Bulkhead with Velcro

Boom Switch and Stabilizer Lock Relays located in Kick Panel

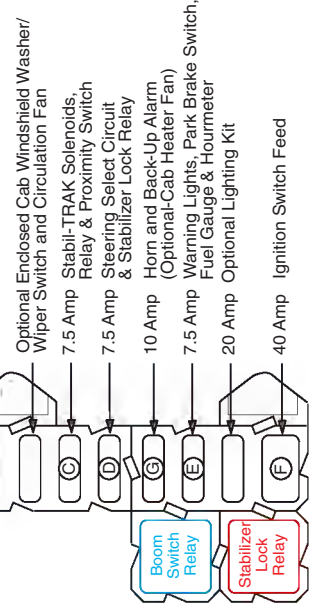

SECTION 10

10054 Stabil-TRAK Electrical Circuit
 Boom Extend Mode 9
 (S/N 9909 & After)

MODE 9	1.	2.	3.	4.	5.	6.
Conditions	Ignition "ON"	Boom Above 40°	Boom Extended	Transmission in Neutral	PB & SB Applied	Outriggers Down

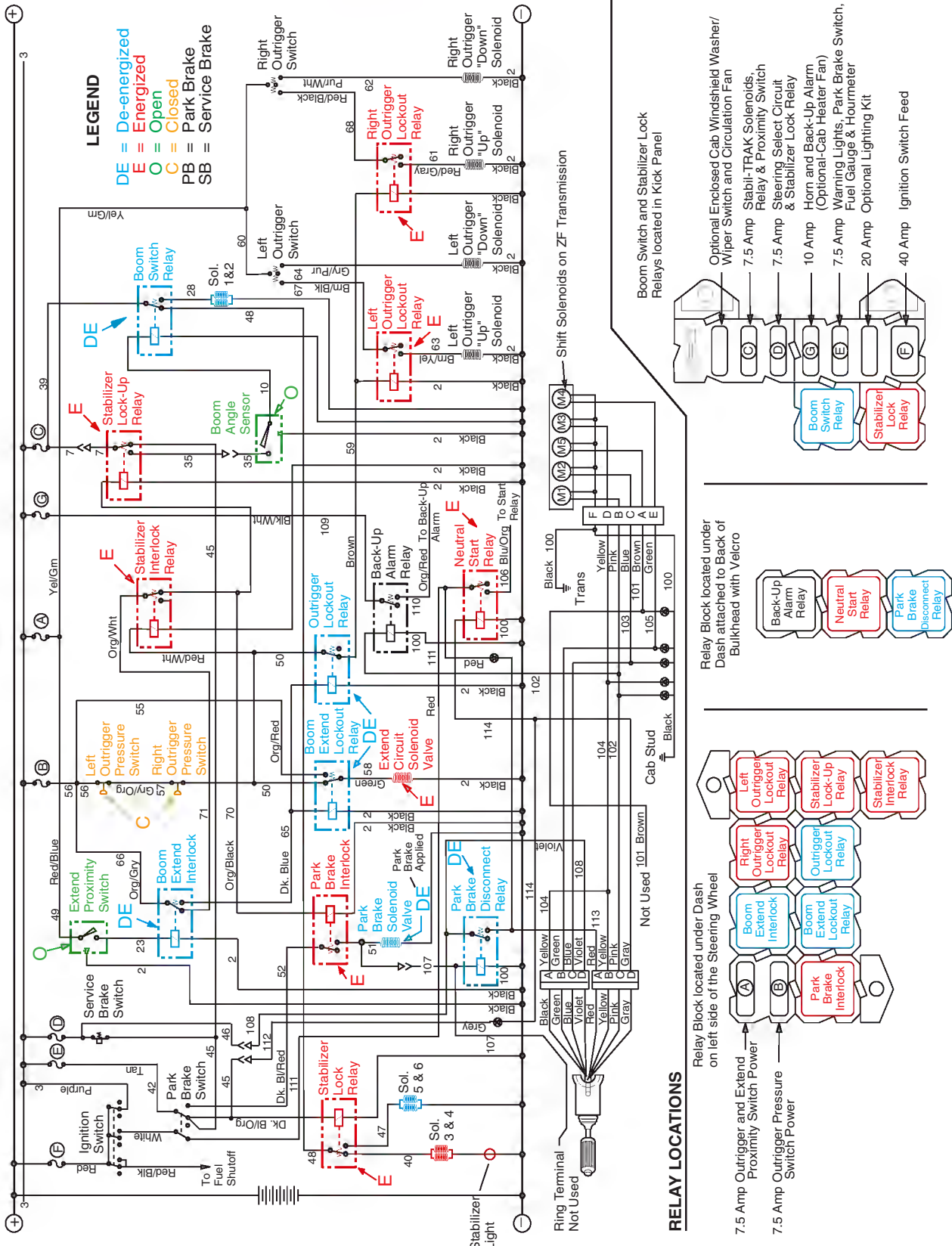

PART NUMBER INDEX

PART NUMBER INDEX

10136599.....	121	10731767.....	83	10731834.....	87, 97	10731900.....	95
10138907.....	121	10731768.....	83	10731835.....	87, 97	10731901.....	95
10701363.....	121	10731769.....	83	10731836.....	87, 97	10731902.....	95
10701562.....	121	10731770.....	83	10731837.....	87, 97	10731903.....	95
10713833.....	131	10731771.....	83	10731838.....	87, 97	10731904.....	95
10715335.....	121	10731772.....	83	10731839.....	87, 97, 101	10731905.....	95
10720643.....	61, 63	10731773.....	83	10731840.....	101	10731906.....	95
10724832.....	131	10731774.....	83	10731841.....	87, 101	10731907.....	95
10724869.....	131	10731775.....	83	10731842.....	87, 101	10731908.....	95
10725149.....	135	10731776.....	83	10731843.....	87, 101	10731909.....	95
10731702.....	73	10731777.....	83	10731844.....	87, 101	10731910.....	95
10731704.....	75	10731778.....	83	10731845.....	87, 101, 109	10731911.....	97
10731705.....	77	10731779.....	83	10731846.....	87, 101	10731912.....	97
10731706.....	77	10731780.....	83	10731847.....	87, 95, 101	10731913.....	97
10731707.....	77	10731781.....	83	10731848.....	87, 95, 101	10731916.....	101
10731709.....	77, 111, 113, 114	10731782.....	83	10731849.....	87, 95, 101	10731917.....	101
10731710.....	77, 111	10731783.....	83	10731850.....	87, 95, 101	10731918.....	101
10731711.....	79	10731784.....	83	10731851.....	87, 88, 95, 101, 102	10731919.....	101
10731712.....	79	10731785.....	83	10731852.....	101	10731920.....	101
10731713.....	79	10731786.....	83	10731854.....	91	10731921.....	101
10731715.....	79	10731787.....	83	10731855.....	91	10731923.....	117
10731716.....	79	10731789.....	83, 91, 97	10731856.....	91	10731924.....	117
10731717.....	79	10731790.....	83	10731857.....	91	10731925.....	117
10731718.....	79	10731791.....	83, 91, 97	10731858.....	91	10731926.....	117
10731719.....	79	10731792.....	83, 91, 97	10731859.....	91	10731928.....	101
10731720.....	79	10731793.....	83, 91, 97	10731860.....	91	10731929.....	101
10731721.....	79	10731794.....	83, 91, 97	10731861.....	91	10731930.....	101
10731722.....	79	10731795.....	83, 91, 97	10731862.....	91	10731931.....	101
10731723.....	79	10731796.....	83, 91, 97	10731863.....	91	10731932.....	101
10731724.....	79	10731797.....	83, 91, 97	10731864.....	91	10731933.....	101
10731725.....	79	10731798.....	83, 91, 97	10731865.....	91	10731934.....	101
10731726.....	79	10731799.....	83, 91, 97	10731866.....	91	10731935.....	101
10731727.....	79	10731800.....	83, 91, 97	10731867.....	91	10731936.....	101
10731728.....	79	10731801.....	83, 91, 97	10731868.....	91	10731937.....	101
10731729.....	79	10731802.....	83, 92, 97	10731869.....	91	10731938.....	101
10731730.....	79	10731803.....	83, 92, 97	10731870.....	91	10731953.....	105
10731731.....	79	10731804.....	83, 92, 97	10731871.....	91	10731954.....	105
10731732.....	79	10731805.....	83, 92, 97	10731872.....	91	10731955.....	105
10731734.....	79	10731806.....	84, 92, 97	10731873.....	91	10731956.....	105
10731736.....	81	10731807.....	84, 92, 97	10731874.....	91	10731957.....	105
10731737.....	81	10731808.....	84, 92, 97	10731875.....	91	10731958.....	105
10731738.....	81	10731809.....	84, 92, 97	10731876.....	91	10731959.....	105
10731739.....	81	10731810.....	84, 92, 97	10731877.....	91	10731960.....	105
10731741.....	81	10731811.....	87, 92, 97	10731878.....	91	10731961.....	105
10731742.....	81	10731812.....	87, 92, 97	10731879.....	91	10731962.....	105
10731743.....	81, 117	10731813.....	87, 92, 97	10731880.....	91	10731963.....	105
10731744.....	81	10731814.....	87, 92, 97	10731881.....	91	10731964.....	105
10731745.....	81	10731815.....	87, 92, 97	10731882.....	91	10731965.....	105
10731746.....	81	10731816.....	87, 92, 97	10731883.....	91	10731966.....	105
10731747.....	81	10731817.....	87, 92, 97	10731884.....	91	10731967.....	105
10731748.....	73, 81	10731818.....	87, 92, 97	10731885.....	91	10731968.....	105
10731749.....	81	10731819.....	87, 92, 97	10731886.....	91	10731969.....	105
10731750.....	81	10731820.....	87, 92, 98	10731887.....	92	10731970.....	105
10731751.....	73, 81, 107	10731821.....	87, 92, 98	10731888.....	92	10731971.....	105
10731752.....	81	10731822.....	87	10731889.....	95	10731972.....	105
10731753.....	81	10731823.....	87	10731890.....	95	10731973.....	105
10731754.....	81	10731824.....	87, 97	10731891.....	95	10731974.....	105
10731756.....	81	10731825.....	87, 95, 98	10731892.....	95	10731975.....	105
10731759.....	81	10731826.....	87, 95, 98	10731893.....	95	10731976.....	105
10731761.....	83, 91, 97	10731827.....	87, 95, 98	10731894.....	95	10731977.....	105
10731762.....	83	10731828.....	87, 95, 101	10731895.....	95	10731978.....	107
10731763.....	83	10731829.....	87, 95, 101	10731896.....	95	10731979.....	107
10731764.....	83	10731830.....	87, 95, 101	10731897.....	95	10731980.....	107
10731765.....	83	10731831.....	87, 95	10731898.....	95	10731981.....	107
10731766.....	83	10731832.....	87, 95, 101	10731899.....	95	10731982.....	107
		10731833.....	87			10731983.....	107

PART NUMBER INDEX

10731984	107	10732065	114	1319223.....	83	2712012	179, 181, 195
10731985	107	10732067	114	1319224.....	83, 91, 97	2712092	195
10731986	107	10732068	114	1319225.....	87, 97	2712112	179, 181
10731987	107	10732069	114	1319226.....	91	2712122	179, 181
10731988	107	10732070	114	1319227.....	91	2712142	179, 181
10731989	109	10732071	114, 117	1319230.....	97	2712332	195
10731992	109	10732072	114	1319234.....	101	2712872	191, 207
10731993	109	10732076	114, 117	1319235.....	101	2712942	179, 181, 183
10731994	109	10732078	117	1319237.....	107	2712952	209
10731995	109	10732081	117	1319238.....	109	2712973	239
10731996	109	10732082	117	1319240.....	109	2712983	235
10731997	109	10732083	117	1319241.....	109	2712993	155, 159, 163
10731998	109	10732085	119	1319242.....	109	2713054	163
10731999	109	10732089	119	1319243.....	109	2713082	207
10732000	109	10732090	119	1319244.....	109	2713212	207
10732001	109	10732091	119	1319245.....	109	2713222	191
10732002	109	10732092	119	1319246.....	109	2713242	179, 181
10732003	109	10732093	107	1319247.....	109	2713262	187
10732004	109	10732094	107	1319248.....	109	2713282	187
10732005	109	10732095	73, 107	1319249.....	109	2713292	183
10732007	111	10732097	107	1319250.....	109	2713322	199
10732009	111	10732098	107	1319251.....	109	2713332	179, 181, 193
10732011	111	10732099	107	1319252.....	109	2713333	233
10732012	111	10732101	107	1319253.....	109	2713363	245
10732013	111	10732103	97	1319254.....	109	2713432	179, 181
10732015	113	10732104	97	1319255.....	109	2713442	183
10732017	111, 114	10732105	97	1319256.....	111	2713452	191
10732018 ..	113, 114, 117	10732106	97	1319257.....	111	2713642	191, 207
10732021	111	10732107	87, 97	1319259.....	111	2713803	227, 229
10732022	111	10732110	75	1319260.....	111	2713853	231
10732023	111	10732111	75	1319261.....	111	2714973	237
10732024	111	10732112	75	1319262.....	113	2714993	229
10732025	111	10732113	75	1319263.....	113	2716163	243, 315
10732027	113	10732114	75	1319264.....	113	2716173	225
10732028	113	10732115	75	1319265.....	113	2716516	189
10732029	113	10732116	75	1319266.....	113	2716545	199
10732030	113	10732117	75	1319267.....	113	4100181	287
10732031	113	10732118	75	1319268.....	113	4105171	287
10732032	113	10732119	75	1319269.....	113	4105262	287
10732033	113	10732120	75	1319270.....	114	4105621	43, 287
10732034	113	10732121	75	1319271.....	117	4106561	321
10732035	113	10732122	75	1319272.....	117	4106681	287
10732036	113	10836774	131	1319273.....	117	4106761	287
10732037	113	10837660	111	1319274.....	117	4106781	287
10732038	113	10837728	113	1319275.....	119	4106872	287
10732039	113	10837948	256	1319276.....	119	4106991	287
10732040	113	10839156	105	1319277.....	119	4107001	287
10732041	113	1319203	73	1319278.....	119	4107182	335, 345
10732042	113	1319204	73	1319279.....	119	4107232	287
10732043	113	1319205	73	1319283.....	29	4107243	287
10732044	113	1319206	73	1319285.....	83	4107252	287
10732045	113	1319207	73	1319286.....	83	4107272	287
10732046	113	1319208	73	1319287.....	83	4107283	287
10732047	113	1319209	73	1319288.....	83	4107342	288
10732048	113	1319210	73	1319573.....	81	4107352	287
10732049	113	1319211	73	2220765.....	183	4107402	287
10732050	113	1319212	73	2705122.....	195	4107412	287
10732051	113	1319213	73	2710802.....	179, 181	4107442	287
10732053	113	1319214	77	2711613.....	247	4107452	287
10732054	113	1319215	79, 91	2711852.....	187, 189	4107462	287
10732055	113	1319216	79	2711872.....	183, 185	4107482	287
10732056	113	1319217	79	2711892.....	193	4107572	288
10732058	113	1319218	79, 109	2711972....	179, 181, 183,	4107601	287
10732060	113, 114	1319219	81	185		4107632	288
10732061	113	1319220	81, 97, 111	2711982.....	209	4107692	299, 317
10732063	113	1319221	81	2711992....	179, 181, 298,	4107702	299, 317
10732064	114	1319222	81	311, 313		4107712	299, 317

PART NUMBER INDEX

4107812.....335, 345	7081031 37	7096562 291	7110782.....281
4107822.....335, 345	7082292 25	7096592 123	7111122.....199
4107832.....335, 345	7082311 11, 291, 293, 297, 323, 327, 329	7096632 127	7111164.....11
4107901.....287	7082342 ... 291, 293, 294, 297, 323, 327, 329	7096692 155	7111191.....37, 281
4107922.....288	7082362 ... 291, 293, 297, 323, 327, 329	7096702 ... 294, 297, 323, 327, 329	7111203.....37
4107971.....25	7082971 15	7096772 291	7111402.....207
4107981.....25	7083054 297, 305	7096882 ... 291, 293, 297, 323, 327	7111473.....11
4107992.....288	7083963 23	7097174 11	7111572....291, 293, 297, 323, 327, 329
4108002.....288	7083992 297, 329	7097233 15	7111832.....25, 287
4108041.....287	7084792 11	7097323 171	7111842.....25, 287
4108081.....287	7084821 11	7097382 291	7111952.....71
4108161.....147, 148	7084902 25	7097452 169	7111994.....298, 317
4108181.....287	7085073 ... 297, 298, 299, 305, 307, 309, 311, 313, 317	7097523 ... 297, 298, 299, 305, 307, 309, 311, 313, 317	7112092.....17
4108201.....287	7085102 303	7097533 ... 297, 298, 299, 305, 307, 309, 311, 313, 317	7112102.....15
4108232.....298, 313	7085411 ... 298, 311, 313	7097543 ... 297, 298, 299, 305, 307, 309, 311, 313, 317	7112302.....281
4108302.....287	7085422 155, 159, 163	7097682 291	7112391.....288
4108441.....287	7085501 ... 298, 311, 313	7098142 33	7112422.....265, 267
4110113.....287	7085552 303	7098262 11	7112452.....191, 207
4110119.....287	7085562 303	7098271 213	7112511.....39, 265, 267, 269
4110120.....287	7085571 303	7098293 197, 199	7112523.....299, 319
4110123.....287	7086304 297, 307	7098342 15	7112533.....299, 319
4110124.....287	7086471 ... 297, 298, 299, 305, 307, 309, 311, 313, 317	7098354 297, 311	7112582.....283
4110125.....287	7086742 169	7098563 9	7112592.....283
5721202.....281	7088283 169	7098733 147, 151	7112642.....299, 319
5724284.....156	7088352 156, 160	7098762 ... 271, 273, 275	7112732.....327
5724302.....9	7088522 35	7098864 271	7112804.....335, 345
5724622.....291	7089044 298, 311	70988973 281	7113024.....335, 345
5724742.....11	7089054 297, 311	7099072 183, 216	7113952.....337
5746411.....329	7089722 239	7099312 9	7113982.....337
6604662.....299, 317	7089781 331, 337	7099324 17	7114032.....327
6604712.....195	7090634 315	7099332 25, 288	7114112.....293, 323
6604882....179, 181, 183, 185, 197, 200	7090751 23	7099352 25, 287	7114542.....273, 275
6604912.....203	7090814 309	7099362 288	7114604.....267
6604972.....195	7090822 315	7099522 147, 151	7114612.....271
6604982.....191	7090832 315	7099532 147, 151	7114754.....267
6605202.....183, 191	7090871 315	7099692 151	7114763.....265
6605652.....197, 199	7090891 315	7099702 151	7114922.....329
6605772.....195	7090951 315	7099742 15	7114941.....300, 319
6608621.....298, 317	7091323 43	7099832 127	7115114.....283
6611752....195, 299, 317	7091373 315	7099882 ... 271, 273, 275, 277, 279, 283	7115163.....265
6619261 123	7092292 9, 291	7099912 ... 156, 160, 164	7115432.....315
6620531 9	7092533 147, 148	7099923 283	7115652.....253
70020428.....245	7092612 147	7099943 156	7115662.....231
70023112.....233	7093772 ... 156, 160, 164	7110002 315	7115712....197, 199, 256
7010491-OM.....287	7093783 ... 156, 160, 164	7110022 169	7116152.....288
7024574.....245	7094562 213	7110042 323	7116162.....288
7029860.....39	7094592 155	7110172 329	7116632.....283
7047041.....265	7094682 11	7110333 151	7116642.....293, 323
705435171, 121, 155, 159, 163	7095272 ... 155, 159, 163	7110342 151	7116652.....293, 323
7054632....155, 159, 163	7095282 155, 159, 163	7110352 151	7116662.....293, 323
7057141155, 159, 163, 197	7095302 171	7110494 299, 317	7116691.....293, 323
7058372.....281	7095312 297, 329	7110694 298, 317	7116784.....293
7062922.....299, 317	7095342 71	7110702 299, 317	7116792.....291
7065482....298, 311, 313	7095352 297, 329	7110712 299, 317	7116812.....293, 323
7068651.....271	7095393 171	7110722 299, 317	7116854.....291
7070191.....298, 313	7095452 11	7110744 321	7117031....335, 341, 343
7075191.....41	7095522 297, 329	7110762 147	7117072.....293, 323
7075611.....291	70955831 ... 155, 159, 163	7110772 147	7117113.....297
7077481....298, 311, 313	7096471 71		7117133.....329
7077501....298, 311, 313	7096552 291		7117204.....298, 313
7077511....298, 311, 313			7117244.....298, 313
7079162.....169			7117254.....298, 313
7079442.....9			7117264.....298, 313
7080891.....37			7117282.....261
			7117292.....261

PART NUMBER INDEX

7117414.....	327	7127871.....	173, 175	7150412.....	179, 181	8032584.....	57
7117502....	293, 323, 327	7127881.....	173, 175	7150432.....	189	8032585.....	57
7117513.....	294	7128772... ..	297, 298, 305, 311, 313	7150442.....	189	8032586.....	57
7117523.....	294	7128782.....	299, 317	7150452.....	189	8032587.....	57
7117534.....	327	7128792... ..	297, 298, 307, 311, 313	7150472.....	25, 287	8032588.....	57
7117542.....	323	7128802... ..	298, 299, 309, 311, 313, 317	7150492.....	185	8032589.....	57
7117572.....	293, 323	7129261.....	15	7150502.....	185	8032592.....	57
7117582.....	327	7129313.....	9	7150521.....	279	8032593.....	57
7117692.....	261	7129323.....	9	7150523....	156, 160, 164	8032594.....	58
7117704.....	269	7129382.....	277, 279	7302077.....	15	8032595.....	57
7117812.....	191, 207	7129392.....	277, 279	77104027.....	57	8032604.....	63
7118222... ..	173, 175, 271, 273, 275, 277, 279	7130564.....	261	77104031.....	57	8032605.....	63
7118662.....	297	7130912.....	253	77104116.....	53	8032606.....	63
7118682.....	329	7131274.....	261	77104164.....	57	8032607.....	63
7118692.....	327	7131852.....	69	77104186.....	61, 63	8032608.....	63
7118854.....	323	7132912.....	155, 159	77104198.....	61	8032609.....	63
7118882... ..	297, 305, 307, 309	7133022.....	155, 159	77104215.....	61	8032611.....	63
7118892... ..	297, 305, 307, 309	7133802.....	187, 189	77104284.....	67	8032612.....	58
7118941.....	39, 47	7133812.....	187, 189	8032500.....	53	8032613.....	58
7119341.....	298, 313	7133823.....	191	8032501.....	53	8032615.....	61, 63
7119351....	335, 341, 343	7133833.....	191	8032502.....	53	8032620.....	57, 61, 63
7119362... ..	331, 333, 335, 337, 339, 341, 343	7133843.....	207	8032503.....	53, 54, 61	8032622.....	61
7119372... ..	331, 335, 337, 341, 343	7133853.....	207	8032504.....	53	8032623.....	61
7119632.....	147	7134832.....	277	8032505.....	53	8032624.....	61
7119642.....	147	7134894.....	279	8032506.....	53, 61	8032625.....	61
7119652.....	147	7135942.....	25	8032509.....	53	8032626.....	61
7119662.....	147	7136034....	173, 175, 213	8032510.....	53	8032627.....	63
7119813.....	195, 259	7136374.....	216	8032511.....	53	8032628.....	61, 63
7120191.....	333, 339	7137132.....	47	8032515.....	53	8032629.....	61
7120742.....	303	7137643.....	164, 167	8032517.....	53	8032631.....	61
7121013.....	183	7138164.....	213	8032518.....	53	8032632.....	61
7124331.....	9, 15, 281	7138186.....	121	8032521.....	53, 54	8032633.....	61
7124471.....	203	7138208.....	121	8032522.....	53	8032635.....	61
7124491.....	315	7138209....	173, 175, 213	8032523.....	53	8032637.....	61
7124531.....	41	7138240.....	147	8032526.....	53	8032638.....	61
7125251.....	41	7138241.....	148	8032528.....	54	8032640.....	61
7125271.....	41	7138290.....	164	8032532.....	54	8032641.....	61
7125421.....	173	7138291.....	156, 160	8032535.....	54	8032642.....	61
7125521.....	15	7138297.....	164	8032536.....	54	8032643.....	61, 63
7125691.....	15	7138301.....	156, 160	8032537.....	53	8032644.....	61
7125741... ..	298, 311, 313, 329	7138302.....	9	8032538.....	53	8032645.....	61
7125801.....	315	7138340.....	216	8032539.....	53	8032646.....	61
7125811.....	297, 329	7138468.....	283	8032541.....	53, 57	8032647.....	61
7125861.....	9	7138469.....	283	8032542.....	53, 57	8032648.....	61
7126662.....	323	7138614.....	11	8032543.....	53, 57	8032649.....	61
7126684....	273, 275, 277	7138714....	173, 175, 213	8032545.....	53, 57	8032650.....	61
7126922.....	169	7138738.....	331, 337	8032546.....	53	8032651.....	61
7126953.....	169	7138848.....	164	8032547.....	53	8032652.....	61, 63
7126962.....	169	7138980....	294, 324, 327	8032549.....	53	8032653.....	65
7126992.....	169	7139688.....	121	8032550.....	57	8032654.....	65
7127003....	155, 159, 163	7143900.....	23	8032552.....	57	8032655.....	65
7127013....	155, 159, 164	7144000.....	23	8032553.....	57	8032656.....	65
7127022.....	169	7150082.....	121	8032554.....	57	8032657.....	65
7127034.....	160, 163	7150182.....	121, 129	8032555.....	57	8032658.....	65
7127043.....	160, 163	7150192.....	121, 129	8032556.....	57	8032659.....	65
7127081.....	175	7150202.....	121, 125	8032558.....	57	8032661.....	65
7127091.....	35	7150282.....	205	8032559.....	57	8032663.....	65
7127102.....	35	7150302.....	185	8032560.....	57	8032665.....	65
7127282.....	17	7150312.....	181	8032563.....	57	8032666.....	67
7127852.....	329	7150361.....	15	8032566.....	57, 61	8032670.....	67
7127862.....	329	7150371.....	25, 287	8032567.....	57	8032672.....	67
		7150382.....	15	8032568.....	57	8032673.....	67
		7150393.....	11	8032573.....	57	8032674.....	67
		7150402.....	279	8032574.....	57	8032675.....	67
				8032579.....	57	8032676.....	67
				8032580.....	57	8032678.....	67
				8032581.....	57	8032679.....	67

PART NUMBER INDEX

8032680.....67	8033051 15	8033340 ... 156, 160, 164, 271, 273, 275, 277, 279	8033768.....261
8032681.....67	8033053 15	8033342 155, 159, 163	8033769.....261
8032682.....67	8033065 39, 47, 265, 267, 269	8033344 65	8033770.....261
8032702.....241	8033072 17	8033347 65	8033771.....69
8032714.....227, 239	8033075 39, 47	8033348 61	8033772.....69
8032726.....231, 233, 235	8033076 17	8033349 53	8033773.....69
8032728.....231, 233	8033077 17	8033351 63	8033774.....69
8032752.....216	8033078 17, 265, 267, 269	8033355 61	8033775.....69
8032753.....27	8033079 17	8033356 61	8033776.....69
8032756.....265, 267, 269	8033081 17, 49	8033357 61	8033777.....69
8032762.....171	8033082 18	8033358 61	8033778.....69
8032764.....171	8033084 17	8033359 63	8033779.....69
8032793.....41	8033085 17	8033360 63	8033780.....69
8032794.....41	8033086 17	8033361 63	8033781.....69
8032816.....145	8033087 17	8033362 63	8033782.....245
8032826.....137, 141	8033088 17	8033363 63	8033784.....245
8032875.....135	8033090 17	8033364 63	8033785.....245
8032876.....135	8033092 17	8033365 63	8033786.....245
8032877.....135	8033094 17	8033368 63	8033788.....245
8032880.....135	8033097 127	8033371 63	8033789.....245
8032881.....135	8033098 127	8033372 63	8033791.....69
8032882.....135	8033102 39	8033373 58, 63	8033796.....123
8032885.....135	8033103 39	8033374 63	8033797.....123
8032886.....135	8033104 39	8033375 63	8033798.....123
8032891.....138, 141	8033178 35	8033376 63	8033799.....138
8032892.....138, 142	8033188 53	8033384 57	8033801.....249
8032893.....138, 142	8033189 53	8033385 58	8033802.....132
8032894.....137, 141	8033190 57	8033386 58	8033803.....137, 141
8032895.....131, 137, 141	8033191 57	8033387 65	8033804.....135
8032896.....137, 141	8033192 57	8033406 ... 271, 273, 275	8033805.....135
8032897.....137, 141	8033193 53	8033479 17, 49	8033806.....131
8032898.....137, 141	8033194 57	8033652 125	8033809.....131
8032899.....137, 141	8033195 57	8033704 233	8033810.....131
8032900.....137, 141	8033196 57	8033715 233	8033811.....249
8032901.....137, 141	8033197 57	8033721 233	8033812.....249
8032902.....137, 141	8033198 53, 63	8033722 239	8033813.....249
8032903.....137, 141	8033201 25, 265, 267, 269	8033723 239	8033814.....249
8032904.....137, 141	8033202 67	8033724 239	8033815.....135
8032906.....137, 141	8033203 67	8033725 239	8033816.....135
8032910.....137, 141	8033204 67	8033727 227	8033817.....135
8032912.....137, 141	8033205 67	8033728 227	8033818.....135
8032913.....138, 141	8033228 131	8033729 227	8033820.....135
8032914.....138, 142	8033238 67	8033730 227	8033821.....135
8032920.....137	8033239 67	8033731 227	8033822.....135
8032922.....137, 141	8033240 27	8033732 223	8033823.....135
8032923.....137, 141	8033241 27	8033733 223	8033824.....135
8032930.....145	8033242 27	8033734 223	8033826.....137, 141
8032949.....137, 141	8033243 27	8033735 223	8033827.....137, 141
8032972.....137, 141	8033254 259	8033737 223	8033828.....137, 141
8032973.....137, 141	8033299 53	8033738 223	8033829 137, 141
8032974.....137, 141	8033302 53	8033740 235	8033831.....138, 141
8032979.....135	8033303 53	8033741 235	8033832.....138, 141
8032983.....138, 142	8033304 54	8033742 235	8033833.....17
8032984.....137, 141	8033305 54	8033744 231, 233	8033834.....17
8032985.....137, 141	8033306 54	8033745 231, 233	8033835.....18
8032993.....261	8033307 54	8033746 231	8033837.....18
8033003.....125	8033308 54	8033747 231, 233	8033838.....18
8033004.....125	8033309 54	8033748 241	8033839.....18
8033006.....127	8033310 54	8033749 241	8033840.....18
8033007.....123, 127	8033311 54	8033750 241	8033841.....21
8033008.....127	8033312 54	8033751 241	8033842.....21
8033009.....123, 127, 135	8033313 54	8033753 261	8033843.....21
8033012.....137, 141	8033314 53	8033756 233	8033844.....21
8033022.....15	8033318 58	8033760 261	8033845.....21
8033031.....15		8033761 261	8033846.....21
8033044.....17		8033763 261	8033847.....21
8033050.....15			

PART NUMBER INDEX

8033848.....	21	8033923.....	215	8034531.....	255	8034821.....	251
8033849.....	21	8033924.....	215	8034532.....	255	8034822.....	251
8033850.....	21	8033925.....	215	8034534.....	253	8034823.....	251
8033851.....	21	8033926.....	215	8034538.....	253	8034824.....	251
8033852.....	21	8033927.....	215	8034539.....	253	8035247.....	223
8033853.....	21	8033928.....	215	8034540.....	253	8035267.....	253
8033854.....	21	8033929.....	215	8034541.....	253	8035268.....	137, 141
8033855.....	21	8033930.....	215	8034542.....	255	8035269.....	137, 141
8033856.....	21	8033931.....	215	8034544.....	21	8035270.....	137, 141
8033857.....	21	8033932.....	215	8034545.....	21	8035271.....	137, 141
8033858.....	21	8033933.....	215	8034546.....	18, 21	8035272.....	137, 141
8033859.....	21	8033934.....	215	8034547.....	21	8035276.....	277, 279
8033860.....	21	8033935.....	215	8034548.....	21	8035308.....	229
8033861.....	21	8033936.....	215	8034549.....	255	8035315.....	225
8033862.....	21	8033937.....	215	8034550.....	255	8035322.....	243
8033863.....	21	8033938.....	215	8034551.....	253	8035386.....	229
8033864.....	21	8033939.....	215	8034552.....	253	8035387.....	253
8033865.....	21	8033952.....	215	8034554.....	255	8035513.....	223, 225
8033866.....	21	8033953.....	215	8034555.....	255	8035514.....	225
8033867.....	21	8033954.....	215	8034556.....	255	8035519.....	243
8033868.....	21	8033955.....	216	8034557.....	255	8035536.....	225
8033870.....	63	8033956.....	216	8034558.....	259	8035539.....	225
8033871.....	63	8033957.....	216	8034559.....	259	8035542.....	229
8033872.....	63	8033958.....	216	8034560.....	259	8035545.....	229
8033873.....	63	8033959.....	215	8034561.....	259	8035547.....	237
8033874.....	63	8033960.....	145	8034562.....	259	8035555.....	167
8033876.....	63	8033961.....	145	8034569.....	261	8035556.....	167
8033877.....	63	8033962.....	145	8034570.....	261	8035557.....	167
8033878.....	63	8033963.....	145	8034571.....	261	8035558.....	167
8033879.....	63	8033964.....	145	8034575.....	261	8035559.....	167
8033880.....	63	8033965.....	145	8034577.....	261	8035560.....	220
8033881.....	63	8033967.....	131	8034578.....	261	8035561.....	220
8033882.....	63	8033968.....	131	8034581.....	137	8035562.....	220
8033883.....	63	8033969.....	131	8034584.....	141	8035563.....	220
8033884.....	63	8033970.....	131	8034585.....	141	8035564.....	220
8033885.....	58, 63	8033973.....	131	8034586.....	141	8035565.....	220
8033886.....	53	8033974.....	131	8034590.....	142	8035566.....	220
8033887.....	53	8033975.....	131	8034593.....	125	8035567.....	219
8033888.....	53	8033976.....	131	8034684.....	251	8035568.....	219
8033889.....	53	8033977.....	131	8034688.....	138, 142	8035569.....	219
8033890.....	67	8033978.....	131	8034691.....	251	8035570.....	219
8033896.....	215	8033979.....	131	8034692.....	137, 141	8035571.....	219
8033897.....	215	8033980.....	131	8034693.....	137, 141	8035572.....	219
8033898.....	215	8033981.....	131	8034694.....	27	8035573.....	219
8033899.....	215	8033983.....	131	8034695.....	237	8035574.....	219
8033900.....	215	8033984.....	131	8034697.....	253	8035575.....	219
8033901.....	215	8033985.....	131	8034797.....	47	8035577.....	219
8033902.....	215	8033986.....	131	8034798.....	47	8035578.....	219
8033903.....	215	8033987.....	131	8034799.....	47	8035579.....	219
8033904.....	215	8033988.....	131	8034800.....	47	8035580.....	219
8033905.....	215	8033989.....	131	8034801.....	39, 47	8035581.....	219
8033906.....	215	8033990.....	131	8034803.....	47	8035582.....	219
8033907.....	215	8033991.....	131	8034804.....	47	8035583.....	219
8033908.....	215	8033994.....	131	8034805.....	47	8035584.....	219
8033909.....	215	8033995.....	131	8034806.....	47	8035585.....	219
8033910.....	215	8033996.....	131	8034807.....	47	8035586.....	219
8033911.....	215	8033997.....	131	8034808.....	47	8035587.....	219
8033912.....	215	8033999.....	131	8034809.....	47	8035588.....	219
8033913.....	216	8034500.....	131	8034810.....	47, 267, 269	8035589.....	219
8033914.....	215	8034501.....	131	8034811.....	47	8035590.....	220
8033916.....	215	8034502.....	131	8034812.....	215	8035591.....	220
8033917.....	215	8034503.....	131	8034813.....	271, 273, 275	8035592.....	220
8033918.....	215	8034504.....	131	8034814.....	137, 141	8035593.....	220
8033919.....	215	8034505.....	131	8034815.....	39	8035595.....	220
8033920.....	215	8034527.....	255	8034817.....	47	8035596.....	220
8033921.....	215	8034528.....	255	8034818.....	215	8035597.....	220
8033922.....	215	8034530.....	255	8034819.....	138, 142	8035598.....	220

PART NUMBER INDEX

8035607.....229	8180308.....156	8262143.....163	8303638.....15, 303
8035608.....229	8205506.....235	8270014 271, 273, 275	8303655.....9, 291, 315
8035609.....229	8205514.....247	8270134.....277, 279	8303656.....11
8035610.....229	8205545.....247	8270220 155, 159, 163	8303664.....71
8035611.....237	8205546.....247	8270221 ... 155, 159, 163,	8303666.....297, 329
8035612.....237	8205547.....247	271, 273, 275, 277, 279	8303675.... 181, 197, 199,
8035613.....237	8205548.....247	8270602 271, 273, 275	294, 297, 323
8035615.....225	8205640.....235	8270617 ... 271, 273, 275,	8303679.... 156, 160, 164,
8035616.....225	8205655 ... 231, 233, 241,	277, 279	207, 294, 297, 323,
8035617.....125	245, 247, 259, 261	8270625 277, 279	327, 329
8035618.....125	8205656 227, 229, 239	8272009 155, 159	8303681.... 291, 293, 297,
8035620.....125	8205657 223, 225	8272017 163	323, 327, 329
8035621.....125	8205661 247	8273013 171	8303697 23, 43, 159, 163,
8035622.....125	8205726 227	8273237 171	171, 271, 291
8035623.....125	8220008 41, 265, 267,	8273238 171	8303702.... 155, 159, 163
8035624.....125	269	8273240 171	8303705.....15
8035625.....125	8220050 ... 265, 267, 269,	8273241 171	8303715.... 291, 299, 317
8035727.....243	281	8273272 171	8303717.....315
8035728.....243	8220073 39, 271, 273,	8274022 173, 175	8303724.. 9, 71, 121, 155,
8035729.....243	275, 277, 279	8275212 169	159, 163
8035730.....243	8220882 ... 265, 267, 269,	8275240 169	8303729.....11, 15
8035731.....243	283	8275247 169	8303735.....293
8035732.....243	8223016 281	8275248 169	8303738.....283
8035733.....117	8223024 41, 265, 267,	8277161 156, 160, 164	8303739.... 191, 298, 311,
8035734.....117	269	8277162 ... 155, 159, 163,	313
8035773.....129	8223025 ... 265, 267, 269,	271, 273, 275, 277, 279	8303742 35, 37, 155, 159,
8035780.....239	281	8278007 71, 121, 155,	163
8035800.....225	8223216 ... 271, 273, 275,	159, 163	8303744.....155
8035805.....279	277, 279	8278008 ... 155, 159, 163,	8303745.....23
8035806.....279	8223217 ... 213, 271, 273,	197, 199	8303752.....191
8036001.....237	275, 277, 279	8278012 155, 159, 163	8303757.....207
8036243.....261	8223220 25, 265, 267,	8278017 71	8303758.....43
80364021.....21	269	8301002 35	8303770.... 298, 311, 313
8037206.....21	8223221 283	8301402 35	8303772.....297, 329
80384207.....39	8223226 213	8301439 31	8303776.....17, 41
8040258.....9	8223405 25, 265, 267,	8301443 33, 43	8303782.....9, 291
8065062.....299, 317	269	8301456 300, 319	8303784.... 155, 159, 163
8065063.....315	8223419 281	8302147 15	8303790.... 35, 155, 159,
8065214.....294, 323	8223424 281	8302406 37	163
8065634.... 298, 311, 313	8223436 265, 267, 269	8302449 35	8303794.....315
8065639.....15	8223438 265, 267, 269	8302470 .. 31, 33, 43, 121	8303799.....35
8065640.....9, 291	8223442 25, 265, 267,	8303034 11, 15, 25, 33	8303835.....39, 265
8065641.....9	269	8303041 291	8303837.....35, 281
8080613.... 155, 159, 163	8223444 25, 265, 267,	8303106 27, 155, 159,	8303839.....39
80963058.....233	269	163	8303982.....17
8124126.... 331, 333, 335,	8223445 25, 265, 267,	8303519 ... 121, 155, 159,	8303987.... 67, 271, 273,
337, 339, 341, 343	269	164, 185	275, 277
8124131.....337	8223510 271, 273	8303534 15, 23, 37	8303995.....41
8127008.... 339, 341, 343	8223517 265	8303540 ... 17, 27, 33, 39,	8304042.....197, 199
8127009.....337	8223525 283	47, 329	8304608.....197, 199
8127014.....331, 337	8223532 ... 275, 277, 279	8303550 163	8304624.....183
8140309.... 156, 160, 164	8224026 33	8303604 23	8304631.... 197, 199, 259
8160042.....27	8224027 31	8303618 171	8304660.....11
8160046.....35	8225117 ... 267, 269, 283	8303620 57, 58, 291, 293,	8305002 35, 39, 265, 267,
8160059.....43	8229215 265	323, 327, 329	269, 283
8160060.....33	8229216 265	8303621 ... 169, 291, 293,	8305003.....265
8160062.....31	8229218 265	323, 327, 329	8305004.... 11, 25, 35, 37,
8160205.....27	8229226 265	8303622 ... 156, 159, 164,	43, 265, 267, 271, 273,
8160406.....43	8229232 265	207	275, 277, 279
8160417.....27	8229233 ... 267, 269, 283	8303624 323, 327	8305005.....33, 39
8160418.....43	8229234 267, 269	8303626 185, 299, 319	8305006 23, 39, 179, 181,
8160419.....31, 33	8229235 267, 269, 281	8303628 315	271
8160610.....35	8229238 267, 269	8303629 315	8305008. 15, 23, 197, 199
8160617.....33, 43	8262131 155	8303632 281	8305012.... 183, 185, 299,
8160621.....265, 267	8262137 159	8303634 ... 297, 298, 299,	319
8162003.....35	8262138 159	305, 307, 309, 311,	8305014.....213, 281
8180307.... 156, 160, 163	8262142 163	313, 317, 323, 327	8305018.....333, 339

PART NUMBER INDEX

8305021 9	8307026 265, 267	8310112.....15	8405404 171
8305038 279	8307027 269	8310113.....283	8406101 155, 159, 163
8305043 ... 271, 273, 275, 277, 279	8307046 39	8310116.....71	8406105 179, 181, 195
8305201 ... 271, 273, 275, 277, 279	8307047 121	8310129.....213	8410009..... 173, 175
8305402 27, 31, 35, 43	8307052 39	8310136.....11	8420053... 207, 298, 299, 311, 313, 317
8305405 37, 281	8307104 37, 303, 331, 333, 335, 337, 339, 341, 343	8310137..... 197, 199	8420055... 207, 298, 299, 311, 313, 317
8305410 37	8307106 23, 155, 163, 267, 269, 271, 283, 291	8310138.....199	8430005... 207, 298, 299, 311, 313, 317
8305438 ... 271, 273, 275, 277, 279	8307107 315	8310143.....31	8430006... 207, 298, 299, 311, 313, 317
8305601 17, 27	8307109 ... 15, 33, 35, 39, 47, 155, 159, 163, 265, 267	8310144.....31	8430007 173, 175
8305619 303	8307110 11, 37, 156, 163	8310151.....315	8430032 181, 195
8305624 ... 15, 35, 39, 47, 155, 159, 163, 197, 199, 327, 329	8307111 ... 267, 269, 281, 283	8310153..... 197, 200, 261	8430034 173, 175
8305626 23, 155, 159, 163, 171, 173, 175, 187, 189, 191, 197, 199, 213, 298, 311, 313	8307112 ... 300, 319, 335, 345	8310158..... 179, 181	8430035 173
8305627 281	8307113 17, 23, 291	8310159..... 179, 181	8430037 181
8305643 9, 291, 297, 298, 299, 305, 307, 309, 311, 313, 315, 317, 323, 327, 329, 337	8307201 17	8310160.....299, 317	8430046 195
8305644 9, 155, 159, 163, 291, 293, 297, 300, 315, 319, 323, 329, 331, 335, 337, 345	8307202 11	8310161.....299, 317	8430048 41
8305645 15, 155, 159, 163, 169, 197, 199, 291, 293, 298, 311, 313, 323, 329, 331, 335, 337, 341, 343	8307203 11, 39, 159, 164, 171, 207, 298, 313	8310163..... 173, 175	8430064 175
8305646 ... 331, 333, 335, 337, 339, 341, 343	8307204 17, 160, 169, 199, 291, 293, 294, 297, 323, 327, 329	8310170.....37	8444223 215
8305647 17, 291	8307206 17, 183, 185, 281, 293, 323	8310178..... 183, 185	8444227 219
8305650 35	8307207 17, 281	8310195..... 335, 345	8464012 213
8305906 11, 43, 291	8307220 121, 185	8310202....273, 275, 277, 279	8464212 25, 265, 267, 269
8305916 15	8307222 155, 159, 163	8310205.....337	8466305 25, 265, 267, 269
8307002 ... 11, 15, 17, 25, 35, 37, 41, 265, 271, 273, 275, 277, 279	8307904 ... 297, 299, 317, 329	8310209.....293, 323	8466306 15
8307003 17, 35, 265, 267, 269, 283	8307910 291	8310210.....337	8467014 25, 265, 267, 269
8307004 11, 43, 155, 159, 163, 179, 181, 191, 207, 271, 291	8307911 291	8310235.....293, 323	8469028 265, 267, 269
8307005 ... 11, 15, 23, 27, 37, 53, 57, 58, 67, 181, 197, 199, 283, 291, 293, 294, 297, 323, 327, 329	8307912 9, 315	8310245.....293, 323	8469030 25
8307006 23, 121, 125, 271	8307913 9, 315	8310257.....37	8500009 281
8307007 ... 183, 185, 293, 299, 319, 323, 327	8307918 ... 297, 299, 317, 329	8310258.....37	8500036 281
8307009 213, 281	8310001 33	8310259.....9	8500201 281
8307010 15, 71	8310002 39, 155, 159, 163	8310266....297, 305, 307, 309	8520001 293, 323, 327
8307012 9, 15	8310019 ... 331, 335, 337, 341, 343	8310276....297, 305, 307, 309	8520013 9, 225, 247, 291, 297, 315, 329
8307022 ... 271, 273, 275, 277, 279	8310020 331, 337	8310337..... 183, 185	8520021 9, 297, 329
8307023 ... 155, 159, 163, 271, 273, 275, 277, 279	8310026 327	8310344.....15	8520043 138, 142
8307024 35	8310028 155, 159	8310425..... 121, 125	8520045 138, 142
8307025 35, 121, 155, 159, 163, 171, 185	8310029 39	8310427.....121	8520048 138, 142
	8310036 15	8320250.....173	8526035 11, 269
	8310041 ... 271, 273, 275, 277, 279	8320253.....173	8526036... 291, 293, 297, 323, 327, 329
	8310049 15	8320254.....53	8526044 131
	8310050 15	8320262.... 155, 159, 163	8526048 191
	8310051 9, 71	8320265.....213	8526052 81, 107
	8310058 281	8320270.....175	8528071 287
	8310066 9, 337	8322029..... 175, 213	8528074 287
	8310067 .9, 71, 121, 155, 159, 163, 315	8324029.....213	8528085 287
	8310070 15, 197, 199	8340025.....145	8528086 287
	8310077 ... 271, 273, 275, 277, 279	8340034.....35	8528100 287
	8310078 ... 271, 273, 275, 277, 279	8342413.....17	8528101 287
	8310081 199, 207	8342416.....11	8530030 181
	8310093 297, 329	8342807..... 11, 15	8540023 41
	8310111 9	8342808..... 11, 21	8541433 298, 311, 313
		8344010.....11	8541435 173, 175, 213
		8346008.....21	8546407 185
		8346009.....17	8554008 39, 47
		8346010.....17	8580110 31, 33, 43
		8346011.....17	8580111 27
		8360005.....41	8580115 17
		8360008.....41	8580213 11
		8382017..... 335, 345	8580309 41
		8403224 156, 160	8580311 25, 265, 267, 269
		8405007 41	
		8405009..... 173, 175	
		8405104 156, 160, 164	
		8405203.... 156, 160, 163	
		8405209.....185	
		8405305.....171	
		8405307.....171	

PART NUMBER INDEX

8580312.....25, 265, 267, 269	8760037 191, 207	8760459 199	8864041.....23
8580315.....17, 299, 317	8760039 187, 189	8760460 179, 181, 200	8864043.....23
8581007.....11	8760045 207	8760474 179, 181, 183	8864044.....23
8582007.....267, 269	8760102 213	8760475 299, 317	8864045.....23
8582413.....11	8760107 ... 183, 185, 191, 197, 199, 207, 213	8760477 191	8864046.....23
8584001.....41, 191, 197, 199, 207, 209, 265, 267, 269, 271, 273, 275, 277, 279, 281, 298, 299, 311, 313, 317	8760109 ... 179, 181, 187, 203	8760482 183, 185	8866341..... 155, 159, 163
8584003.....41, 209, 265, 267, 269, 281	8760110 ... 179, 181, 193, 195, 197, 199, 213, 298, 311, 313	8760483 187, 189	8866347.....45
8584007.... 179, 181, 183, 185, 187, 189, 195, 203	8760111 187, 189	8760488 179, 181	8866348.....45
8584018.....281	8760113 ... 195, 197, 199, 299, 317	8760493 ... 181, 183, 185, 191	8866350.....45
8585133.....18, 49	8760117 ... 183, 197, 199, 200, 298, 311, 313	8760495 185	8866351.....45
8585134.....17	8760118 179, 183, 213	8760501 ... 179, 181, 185, 195, 213	8866364.....45
8585135.....17	8760134 ... 179, 181, 189, 193	8760504 ... 179, 181, 183, 185	8866381.....39
8585138.....17	8760136 197, 199	8760510 199	8866382.....39
8585139.....17	8760138 189	8760529 185	8866437.....39
8585155.....49	8760140 179, 181	8765204 179, 181, 185	8866492.....39
8585156.....49	8760141 ... 179, 181, 183, 185, 199	8769122 191, 207	8866525.....49
8630000.....197, 200	8760142 207	8769123 191	8866526.....49
8630012.....173, 175	8760143 ... 179, 181, 191, 200, 207	8769127 187, 189	8866527.....49
8630016.....121, 185, 220	8760254 205	8769128 187, 189	8880218-OM.... 121, 123, 127
8630017.....205	8760264 207	8769132 299, 317	8880219-OM.... 121, 125
8640017.....259	8760268 193, 197, 199	8769140 191	8882009..... 121, 127
8640019.....261	8760276 185, 193, 195	8769149 191	8902095.....256
8640028....207, 298, 299, 311, 313, 317	8760302 185	8769158 315	8902111..... 197, 199
8640029....207, 298, 299, 311, 313, 317	8760303 179, 197	8769159 315	8902137.... 197, 199, 259
8640032....207, 298, 299, 311, 313, 317	8760305 187, 189, 205	8769160 315	8902140.....259
8640123.....181	8760307 181, 191	8769161 191, 207	8902141..... 199, 259
8640208.....185	8760308 185	8770012 ... 187, 193, 299, 317	8902152.... 197, 199, 255
8640405.....183	8760311 ... 179, 181, 185, 197, 199, 209, 299, 317	8770016 ... 179, 181, 299, 317	8902186.....253
8640903.... 173, 175, 213	8760313 ... 179, 181, 197, 199, 299, 317	8770030 187	8902193..... 199, 259
8642001....298, 311, 313	8760317 185, 187	8770157 189, 205	8902222..... 195, 259
8642207.....299, 317	8760351 213	8770158 205	8902251.... 187, 189, 259
8642224....291, 297, 329	8760401 ... 179, 181, 183, 185	8770159 185	8902255..... 197
8642235....298, 311, 313	8760407 181, 197, 200	8780031 147	8902260.....239
8642237....331, 333, 335, 337, 339, 341, 343	8760409 299, 317	8780035 151	8902261.....223
8688026....265, 267, 283	8760415 185	8780036 147	8902266.... 197, 199, 261
8700116.....35	8760419 197, 199, 213	8780037 147, 151	8902267.... 197, 199, 261
8700120.....37	8760420 255	8780045 147, 148	8902511.... 231, 233, 241, 247
8720014.....15	8760431 205	8780264 147	8902512.....255
8720015.....15	8760449 179, 181	8786514 147, 148, 151	8902688.....261
8721023.....15	8760451 185, 213, 253	8786516 138, 142	8902690.....261
8721029.....179, 181	8760455 195	8786559 151	8902838.... 179, 181, 259
8750003.....191, 207	8760457 183	8825174 67	8902846.....259
8760011.....195	8760458 197, 200	8841025 71	8903011.....253
8760029.....209		8841040 121	8904001.... 155, 159, 163
		8841314 67	8904047.... 179, 181, 259
		8864036 23	8904049.....259
		8864037 23	8990147..... 15
		8864038 15	90204748.....57
		8864039 23	90204767.....57
		8864040 23	90204788..... 53, 57
			90204793.....57
			90204799.....53
			91334035.....39



8990187



An Oshkosh Corporation Company

Corporate Office
JLG Industries, Inc.
1 JLG Drive
McConnellsburg PA. 17233-9533
USA

☎ (717) 485-5161

📠 (717) 485-6417

JLG Worldwide Locations

JLG Industries (Australia)
P.O. Box 5119
11 Bolwarra Road
Port Macquarie
N.S.W. 2444
Australia
☎ +61 2 65 811111
📠 +61 2 65 813058

JLG Latino Americana Ltda.
Rua Eng. Carlos Stevenson,
80-Suite 71
13092-310 Cam inas-SP
Brazil
☎ +55 19 3295 0407
📠 +55 19 3295 1025

JLG Industries (UK) Ltd
Bentley House
Bentley Avenue
Middleton
Greater Manchester
M24 2GP - England
☎ +44 (0)161 654 1000
📠 +44 (0)161 654 1001

JLG France SAS
Z.I. de Baulieu
47400 Fauillet
France
☎ +33 (0)5 53 88 31 70
📠 +33 (0)5 53 88 31 79

JLG Deutschland GmbH
Max-Planck-Str. 21
D - 27721 Ritterhude - Ihlpohl
Germany
☎ +49 (0)421 69 350 20
📠 +49 (0)421 69 350 45

JLG Equipment Services Ltd.
Rm 1107 Landmark North
39 Lung Sum Avenue
Sheung Shui N. T.
Hong Kong
☎ (852) 2639 5783
📠 (852) 2639 5797

JLG Industries (Italia) s.r.l.
Via Po. 22
20010 Pregnana Milanese - MI
Italy
☎ +39 029 359 5210
📠 +39 029 359 5845

Oshkosh-JLG Singapore
Technology Equipment Pte Ltd
29 Tuas Ave 4,
Jurong Industrial Estate
Singapore, 639379
☎ +65-6591 9030
📠 +65-6591 9031

Oshkosh-JLG (Tianjin) Equipment
Technology, Ltd
Pudong Kerry Parkside
Room 3705
1155 Fang Dian Road
Pudong, Shanghai 201204
China
☎ +0086 21 60311575
📠 +0086 21 60311599

Plataformas Elevadoras
JLG Iberica, S.L.
Trapadella, 2
P.I. Castellbisbal Sur
08755 Castellbisbal, Barcelona
Spain
☎ +34 93 772 4700
📠 +34 93 771 1762

JLG Sverige AB
Enkopingsvagen 150
Box 704
SE - 176 27 Jarfalla
Sweden
☎ +46 (0)850 659 500
📠 +46 (0)850 659 534

www.jlg.com