



PUMA™ SERIES

142 - 213HP RATED POWER
170 - 242HP MAXIMUM POWER - POWER MANAGEMENT



FOR THOSE

EVERY SINGLE DAY, YOU DEMAND MORE. MORE FROM THE LAND. MORE FROM YOURSELF. MORE FROM YOUR EQUIPMENT. WHICH IS WHY WE ALSO DEMAND MORE. MORE POWERFUL ENGINES. MORE PRODUCTIVITY-BOOSTING FEATURES. MORE APPROACHABLE AND KNOWLEDGEABLE DEALERS. WE DEMAND MORE TO BETTER SERVE YOU AND THE NEEDS OF YOUR OPERATION.

LET'S FACE IT. GOALS CHANGE. NEEDS CHANGE. THE WORLD CHANGES. BUT THE NUMBER OF HOURS IN THE DAY NEVER DOES. THAT'S WHY WE'VE DEVELOPED AN EFFICIENT, MULTI-PURPOSE TRACTOR LINE WITH JUST THE RIGHT AMOUNT OF POWER FOR BOTH ROW-CROP AND LIVESTOCK APPLICATIONS – THE NEW PUMA™ SERIES TRACTORS. THEY'RE RELIABLE. THEY'RE DURABLE. THEY'RE FUEL EFFICIENT. THEY'RE PUMA™.



WHO DEMAND MORE



4	MADE IN AUSTRIA
6	CAB ENVIRONMENT
8	OPERATOR CONTROLS
10	ENGINES
12	TRANSMISSION AND PTO
14	DRIVING COMFORT
16	HYDRAULIC SYSTEM
18	SERVICEABILITY
20	OUR SYSTEMS APPROACH
22	SPECIFICATIONS

► **Sculpted front end** means you can make tight turns even with large tyres.

► **A-post instruments** and optional performance monitor keep important functions and vehicle performance data centrally located.

► **Ergonomic Surround Vision cab** delivers an unobstructed 360-degree panoramic view.

INCREASED EFFICIENCY. HIGHER RETURNS.



► **Adjustable Multicontroller V armrest** is ergonomically perfect and includes a fully integrated joystick for control of tractor hydraulics.

► **Noise levels** as low as 70dB(A) provides stress-free operation for a long working day.

► **Suspended cab system** with fully adjustable air suspension seat reduce vibration and enhance operator comfort.

► **Active front axle suspension** continuously monitors terrain changes and reacts in conjunction with hitch settings, brake status, throttle position, and more to create a neutral handling environment.

PUMA™ - MADE IN AUSTRIA

The new Puma™ tractor series is all about efficiency. With six models, ranging from 142 to 213 horsepower (CV), Puma™ tractors provide the right amount of power for primary tillage, cultivation, drilling and transport. Whether it's spring or autumn work or pulling trailers, the Puma™ tractors' outstanding power-to-weight ratio will deliver the precise power you need for top efficiency and fuel savings.

Model	Engine power Unboosted	Engine power Boosted
	Rated hp(CV)/kW @ 2,200rpm	Max. hp(CV)/kW @ 1,900-2,000rpm
Case IH Puma 140	142/104	170/125
Case IH Puma 155	160/117	178/131
Case IH Puma 165	167/123	215/158
Case IH Puma 180	182/134	234/172
Case IH Puma 195	197/145	241/177
Case IH Puma 210	213/157	242/178



► **Power Management** provides up to 37 additional horsepower under specific conditions for road transporting and PTO applications.

► **19th 50kph @ 2,060rpm gear**, enhances fuel efficiency, productivity and minimises noise at top road speeds.

► **Case IH Tier III 6.7L engine** delivers fuel-efficient power up to 242hp.

► **Spacious Surround Vision cab** features curved glass, low noise level and an unobstructed view of your surroundings.

► **Remote-adjustable and heated electric mirror** option lets you change side views at the touch of a button.

► **Automatic climate control** option lets you select the perfect temperature for continuous comfort.

► **Suspended cab** is also available for the ultimate in ride comfort.



CAB ENVIRONMENT

LESS NOISE. LESS FATIGUE.

OUR SURROUND VISION CAB COMBINES PANORAMIC VIEWS WITH THE LOWEST NOISE LEVELS TO REDUCE FATIGUE AND INCREASE PRODUCTIVITY, SEASON AFTER SEASON.

Unsurpassed sight lines and perfect ergonomic controls are all part of the Puma™ cab evolution. Designed with operator comfort and productivity in mind, the cab features Surround Vision with 5.87 square metres of glass and an optional high-visibility cab roof window for unobstructed views in all directions. Noise levels of just 70dB(A) are similar if not better than modern cars!

We have integrated our Multicontroller V armrest into the seat so long days at the wheel become less of a drain on you. All seats are fully adjustable with lumbar support, there is an option of a Low Frequency Seat with heating. The steering wheel can also be tilted and adjusted telescopically so you can always be sure to adopt the healthiest driving posture. We recommend cab suspension for the ultimate in ride comfort.

- ▶ Turn night to day with up to 10 lights. A Xenon High-Intensity Discharge (HID) lighting package is available as dealer installed accessories.

- ▶ High-visibility roof panel option lets you monitor overhead conditions.



► **Ergonomically positioned controls** for maximum comfort. Multicontroller V puts all the tractor's key functions in the palm of your hand.

► **A-post instrument cluster** with a performance monitor tracks important functions and data for convenient, at-a-glance monitoring.

► **AFS 200 or AFS PRO 600 monitor** for controlling major tractor functions and providing up-to-the-second overview of machine status.

► **HMC - Headland Management Control** can program and control up to 30 headland operations.



OPERATOR CONTROLS

TECHNOLOGY THAT IS EASY TO USE.

ALL THE CONTROLS ARE WITHIN EASY REACH AND THE INSTRUMENTATION DISPLAYS ARE CONCENTRATED ON THE RIGHT-HAND A-POST. CASE IH ADVANCED ELECTRONIC TECHNOLOGY AND ENHANCED ERGONOMIC DESIGNS PUT YOU IN CONTROL, RELAXED AND READY FOR THOSE LONG DAYS.

Designed for your convenience and to help you save time, the Multicontroller V puts all the key tractor controls at your fingertips. It is integrated into the seat so when you move, so does your armrest. The electro-hydraulic joystick has multiple functionality and can be used to control the front hitch, mid mount valves or a loader depending on your vehicle configuration.

The A-post instrument cluster displays important tractor and implement data within your line of sight meaning less strain searching for information and more time maximising productivity. The main components of Puma™ tractors are networked using ISOBUS-compatible technology.

- ▶ Standard armrest control with electro-hydraulic joystick, with two or three functions, integrates with armrest controller for added convenience.

(Available on Puma 165, 180, 195 and 210.)

- ◀ Multicontroller V functionality includes all those regularly used functions in one place, gear changes, engagement of transmission modes, direction changes, throttle, Headland Management Control, electronic remote valves and front & rear hitch controls.



- ▶ Fitting a GPS receiver and the AFS Pro 600 colour touchscreen monitor will give you on-the-move performance mapping, and you can improve driving accuracy in combination with an AccuGuide™ auto-steering system.

(Only available on 165, 180, 195 & 210 models.)



▶ Constant Engine Speed mode delivers a constant engine rpm and PTO speed, regardless of load variation, for optimum fuel economy. Two different rpm settings may be stored in memory.

▶ Auto shutdown feature shuts off the engine if sensors indicate high temperatures or low oil pressure.

▶ Power Management is standard on all Puma™ models, providing up to 37 additional horsepower during mobile PTO applications over 1kph or in gear 16 and above during transport.

▶ High horsepower internal components drive up to 242 horsepower.

▶ Electronic injector control on the power stroke minimizes noise.

▶ 600-hour engine oil/filter service interval saves maintenance time and costs.

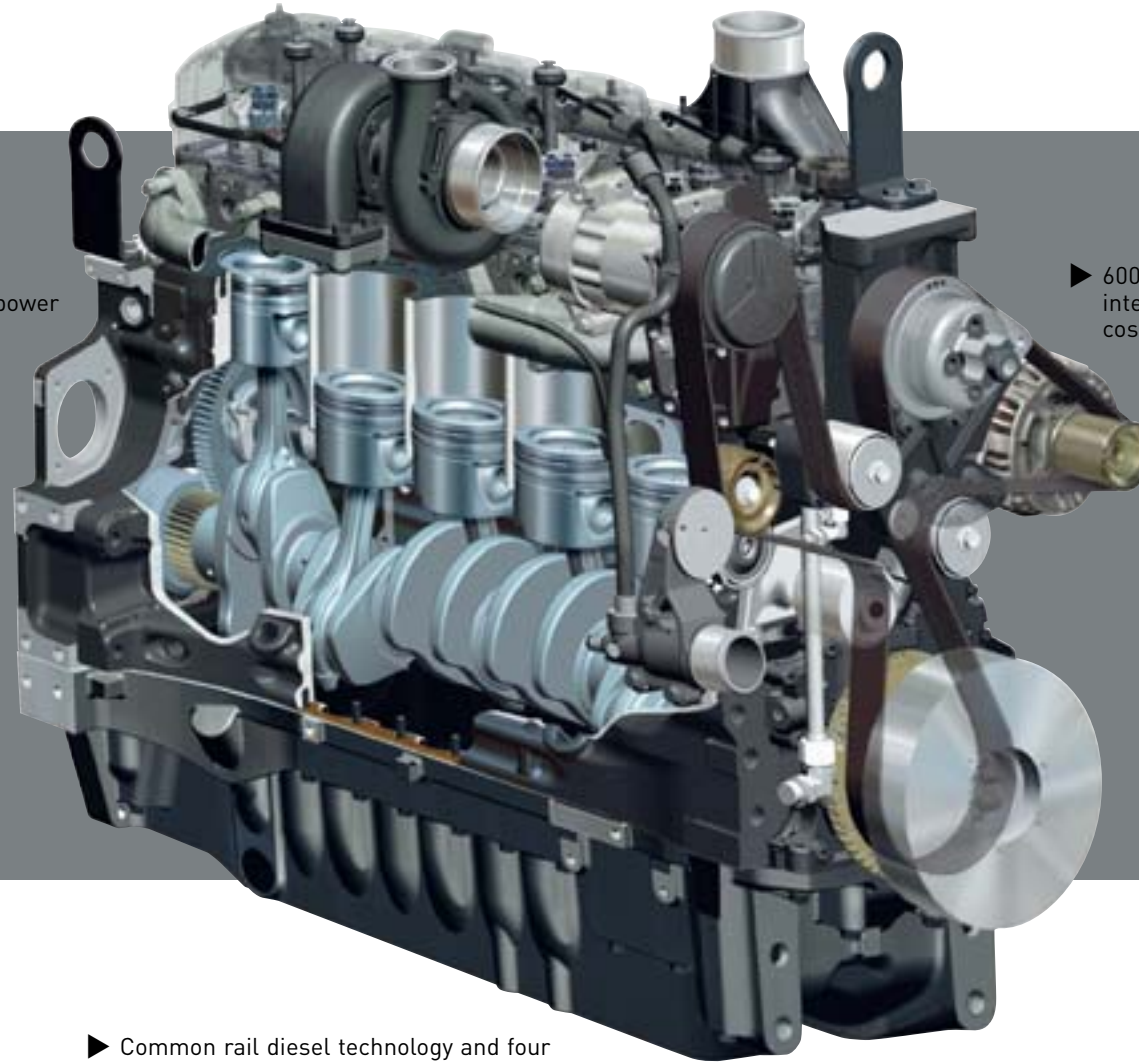

▶ Approved for use with up to 100 percent biodiesel fuel blends (B100).

▶ Vistronic fan.

▶ Common rail diesel technology and four valves per cylinder provide optimal performance and low engine emissions.



FUEL SAVINGS. DURABLE PERFORMANCE.

THE NEW-GENERATION COMMON RAIL TIER III ENGINE FEATURES OUTSTANDING FUEL ECONOMY AND LONG-LASTING DURABILITY.

Rated between 142 and 213 horsepower, all six Puma™ tractors are built with rugged, high performance engines to deliver a reliable source of power. High pressure common rail diesel technology combined with electronic fuel management ensures cost-effective operation for all farming applications.

To ensure both power and efficiency, Puma™ tractors are equipped with a four-valve 5 litre turbocharged, intercooled, low-emission diesel engine. They supply their maximum torque at engine speeds as low as 1400rpm in draft applications and 1600rpm in PTO and transport applications when Power Management is active. The power delivery has been designed so that you have more power at 1900rpm than at 2200rpm. This power growth means you have more lugging ability in tough conditions.

We also provide you with a constant power range of up to 600rpm so work rates can be maintained with lower engine speed, less noise and more efficiency.

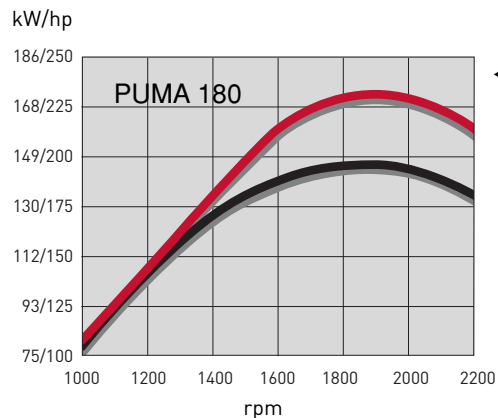

◀ Up to 52hp more can be delivered in addition to your tractor's rated power!

POWER MANAGEMENT

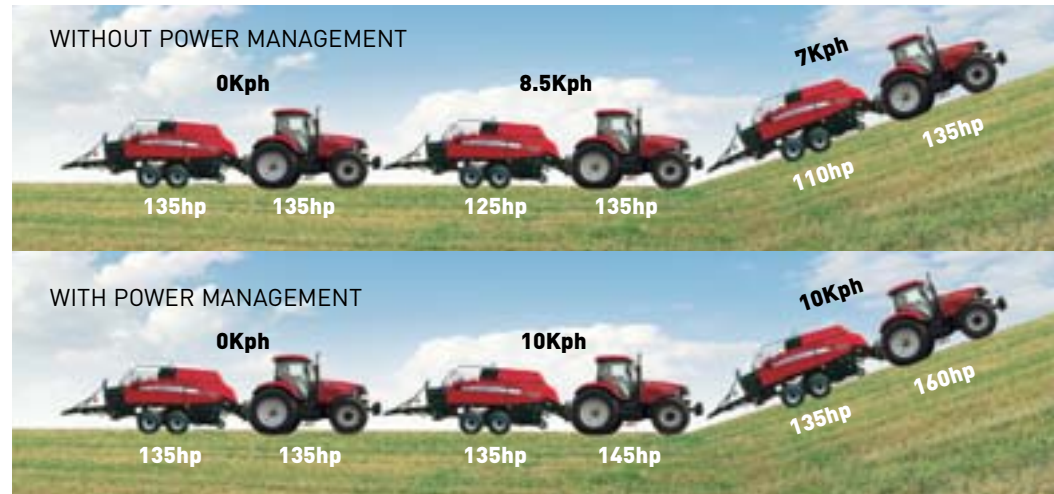

▶ **Power Management** maintains productivity by increasing engine power in tough conditions.

▶ **EGR** – Exhaust gas re-circulation for better efficiency and lower environmental impact.



► **Full Powershift transmission**, provides seamless smooth shifting from zero to 40 or 50kph.

► **Creep gears** offer an additional 10 speeds from 225m/h to 1.6kph @ 2,200rpm.

► **Field mode and Road mode** automatic shifting, leaving the driver free to concentrate on the work.

► Soft Start PTO gradually increases torque to ensure a smooth startup and to protect implement drive shafts.

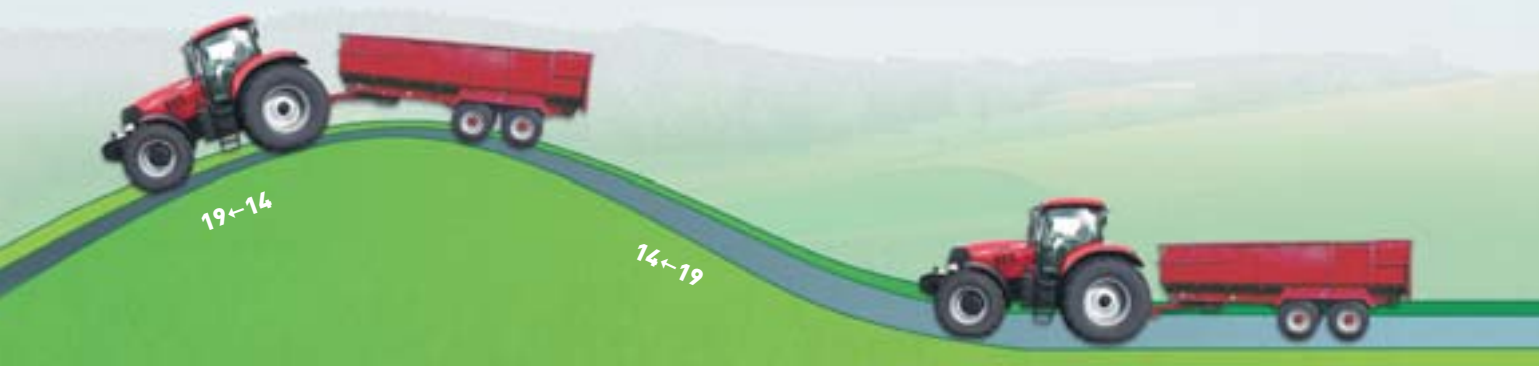
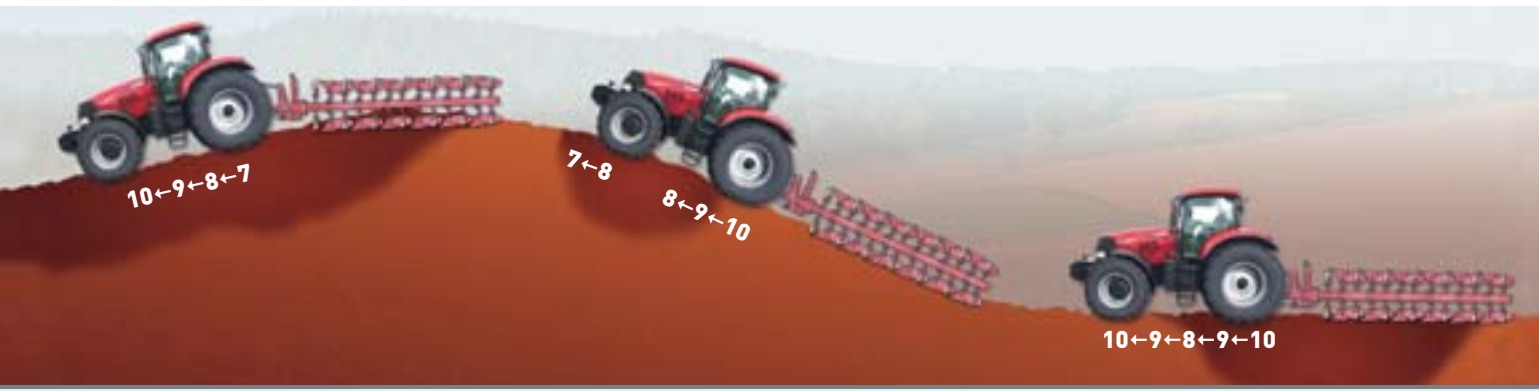

◀ AutoField and AutoRoad modes optimize the transmission and provide automatic shifting based on load for increased productivity and fuel savings.

Gear shifts are smooth because they are based on load. Small loads and shifts will be slow, large and they will be fast.

▼ The Multicontroller V puts full transmission controls at your fingertips.



TRANSMISSION AND PTO

SMOOTH SHIFT QUALITY FOR OPTIMUM PERFORMANCE.

YOUR PUMA FEATURES A TRANSMISSION AND PTO ENGINEERED TO EASILY COPE WITH THE AWESOME OUTPUT OF THE ENGINE, PUTTING YOU IN CONTROL OF THE POWER.

The Puma™ provides you with just the right level of automation you need to step your operation up a gear. There is a choice of transmissions for the range of work you specialise in. Whatever your needs, the transmission technology and optimised operator interface are designed to give you higher operating efficiency and greater ease of operation.

All Pumas are available with an 18 x 6 transmission which is 40kph or a 19 x 6 transmission which can be either 50kph or 40kph at reduced engine revs (approx 1700). The transmissions features field and road modes which automatically shift gears using advanced torque sensing technology for optimum performance and efficiency.

The rear PTO on Puma 140 - 155 features a 540/540E/1000rpm system whereas the 165 - 210 models feature a 540 Economy/1000 or 540/1000rpm system. Drive is direct from the engine flywheel for maximum efficiency. Should you require, a 1000rpm front PTO is available for extra versatility.

The Puma™ PTO management system automatically disengages power to the implements as soon as they are raised, re-engaging when the hitch is lowered again. Designed to protect implement driveshafts and reduce operator fatigue, it can also be programmed into the headland management.



◀ Both the standard and Multicontroller versions are fitted with a steering column-mounted Powershuttle lever, providing smooth direction changes.



► **Auto 4WD and Diff-lock** disengage and engage automatically e.g. on tight corners, when braking and depending on hitch position and forward speed.

► **Active front suspension** for a smooth ride and improved traction.

► **Pneumatic or hydraulic trailer brakes** are available for working with large trailers.



DRIVING COMFORT

MAXIMUM POWER TO THE GROUND.

PUMA™ TRACTORS GIVE YOU POWER AND THE CAPABILITY TO CONTROL IT WITH EASE. IN ADDITION TO THE TRACTION MANAGEMENT SYSTEM, YOUR PUMA™ TRACTOR IS EQUIPPED WITH A RANGE OF FRONT AXLE FEATURES TO IMPROVE STEERING, BRAKING AND SAFETY BOTH ON THE ROAD AND AROUND THE YARD.

Four wheel drive and differential lock management is provided on all Puma™ models. With controls to switch between manual and automatic mode, the operator is able to harness true traction with both mounted and trailed equipment.

Front suspension is available on all models, it improves ride comfort at the same time as providing more control. Less pitching is experienced when travelling at speed with mounted implements, or manoeuvring with a loader. It has 105mm of travel and damping is then controlled via an advanced accumulator and regenerative valve system for a smoother ride. It also has automatic self-levelling according to load.

Puma™ models 165, 180, 195 and 210 have an “Active” suspension system which creates a neutral handling environment due to electronic sensors monitoring acceleration, gear changes, braking, terrain conditions, direction changes and hitch loads. The result is the smoothest ride with no more “nodding” or “pitching”.

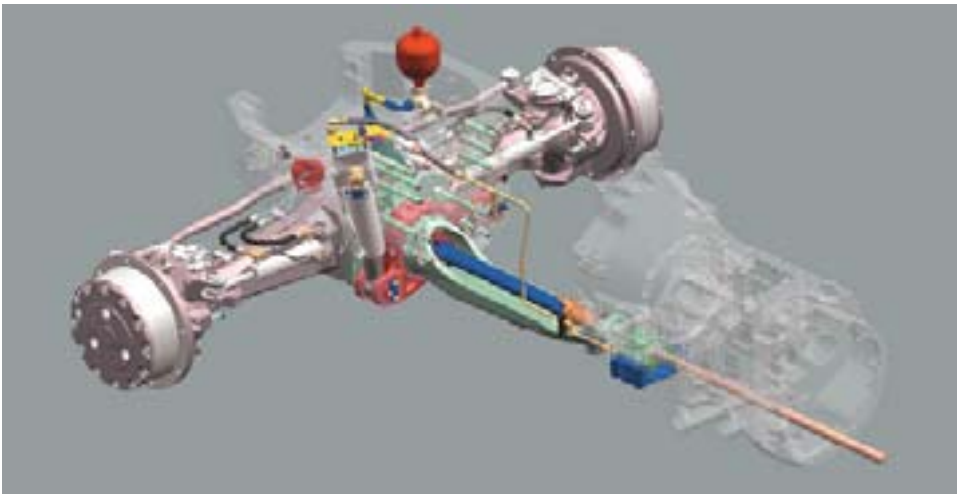

◀ Impressive turning circle. Due to their compact engine dimensions Puma™ tractors have an extremely tight turning radius. Steerable fenders, fitted as standard, give these tractors an additional 30% in steering angle for really superb handling characteristics.

► **Up to 150 litres** per minute pump capacity for excellent response and control even at low engine revs.

► **Hitch Ride Control** is a shock damping system to reduce bounce and improve stability of heavy implements during transport.

► **Up to 8 remote valves** and a power beyond connection are available for even the most complex of implements.

► **Front hitch and 1000rpm PTO** available for multi-task applications.



HYDRAULIC SYSTEM

PUMA™ FOR PRECISION POWER.

THE HYDRAULIC SYSTEM ON A PUMA™ GIVES YOU OUTSTANDING POWER WITH PRECISE CONTROL. THE PRESSURE AND FLOW COMPENSATING (PFC) SYSTEM DELIVERS THE POWER AND FLOW NEEDED FOR TOMORROWS IMPLEMENTS TODAY.

The powerful hitch is designed to make things as straightforward as possible for the operator. The hydraulic system is powered by a variable displacement piston pump delivering up to 150 litres per minute. Up to 4 mechanical standard and 4 electronic remote valves are available and you can choose up to 4 electronic mid mount valves too. All valves are power beyond ready and have capped ports from the factory. Up to 8,650kg can be lifted by the rear hitch, over which you have fingertip control – even outside the cab, thanks to the fender-mounted control buttons.

All Puma™ tractors feature advanced electronic draft control. This system is easy to operate and very effective.



- ▶ Fender-mounted hitch and PTO controls for single-handed implement attachment.



► **Minimum scheduled maintenance** e.g. engine oil can be checked and topped up without lifting the hood.

► **Easy daily checks and cleaning** with maintenance points located at ground level and new simple to clean swing out coolers.

► **Quick and easy trouble shooting** using a service tool plug-in for the laptop.

► **Dealer Installed Accessories** for choice, plus the quality and reliability you demand from Case IH.



► In addition to the extensive range of standard equipment; Case IH offers a comprehensive choice of dealer installed accessories. For example, AFS 200 monitor, AccuGuide™ automatic steering systems and state-of-the-art HiFi sound systems.



SERVICEABILITY

PUMA™ – MAXIMUM UPTIME.

KEEP DRIVING! DAILY CHECKS TAKE NEXT TO NO TIME AND SCHEDULED MAINTENANCE SESSIONS ARE FEW AND FAR BETWEEN. WITH PLENTY OF ADVANCE WARNING FROM THE PERFORMANCE MONITOR TOO, YOU GET SUFFICIENT OPPORTUNITY TO PLAN THEM IN.

Routine servicing is so straightforward on Pumas, daily checks are completed in the time it takes you to fill-up. With the hood raised on gas cylinders, access to the engine and cooling components from the ground is quick and easy.

Pumas are engineered to last. The on-board performance monitor not only notifies operators of routine service and maintenance requirements, it detects critically high engine and transmission temperatures and low oil pressure, and will automatically shut the engine down, if necessary.



► With the hood open, the radiator is completely accessible for easy cleaning and maintenance.

► Troubleshooting is straightforward, but if necessary your Case IH dealer can perform full systems diagnostics on site with a laptop computer.

► **Advanced Farming Systems** available on Puma™ tractors are an essential ingredient for efficiency.

► **AccuGuide™ automatic steering systems** with GPS receiver improve precision farming accuracy a step further.

► **ISOBUS a powerful communication tool** to control ISOBUS compatible implements for highest productivity.

INTEGRATED PRECISION FOR MAXIMUM PRODUCTION



A powerful tool for professional farming.

Increasing yield with the same input or maintaining yield with reduced input, that is what is done with Precision Farming. With the DGPS based system on the

Case IH Axial-Flow® combines, you permanently register your yield and store it, linked to the precise location. That information - in combination with other DGPS based data like crop moisture content and soil variations - is used to

prepare application maps for accurate, site-specific seeding and spraying, thus increasing your overall performance. Precision Farming also reduces labour costs and fuel consumption.

ISOBUS compatibility.

Having defined a communication protocol used across the industry, ISOBUS extends the possibilities of precision farming through more intelligent functions and efficient GPS data integration.

The Case IH AFS AccuGuide™ Autoguidance System.

Operators can concentrate fully on the performance of their implement, while the steering of the tractor or combine is managed by AccuGuide™ Automatic Steering System, designed and developed by Case IH. In combination with DGPS technology this system ensures parallel passes when working in straight lines, curves, pivots, or on undulating ground. When planting, seeding, cultivating or tilling, there is no risk of overlap or missed ground, even in difficult weather conditions or at night.



AFS Pro 600 Display.

This industry-leading user interface system displays data in the cab, stores it for analysis and makes adjustments on the go.

OUR SYSTEMS APPROACH

PARTS & SERVICE

Maintain the productivity of your investment. Case IH and its dedicated dealer network provide excellent support when you take delivery of your new machine and whilst it remains in your ownership. On the farm, you can rely on trained service professionals to maintain the productivity of your investment. Protect the value of your investment. Behind every Case IH product stands an extensive European parts logistics organisation, stocking more than 700,000



part numbers for products old and new. Choosing to fit genuine Case IH parts will maintain the safety, value and performance of your original investment.

- **MAX - the new premium service from Case IH.** We are always ready for you, around the clock, the whole year. Express delivery: when and where you need it. You get top priority during the season because your harvest cannot wait.

The call is free. However some European Operators may apply a charge, if the call is made from a mobile phone. For any information about charge rate, please enquire in advance from your provider.

MAX
00800 227344 00
00800 CASE IH 00
100% Support
100% Availability

FINANCE



Your local Case IH dealer can work with CNH Capital to offer solutions that best fit your budget and business goals.

At CNH Capital, we understand that no two farms or agricultural businesses are the same. That's why we work so hard to understand your needs first. We make it our job to know your business inside and out – your goals, your ideas, and your unique outlook on the future. Then we can put together financial solutions and services that are right for you.



- Extended protection programme. Case IH is at your side giving you the best professional solution: Safeguard from Covéa Fleet. This is the personalised insurance coverage for your Case IH machinery. Please contact your dealer for more details. Subject to status and availability. Terms and conditions apply.



DEALER

Skilled business advisor at your dealership.
Demand more from your Case IH dealership.

Purchasing a stand-alone piece of new equipment? Keeping a whole fleet up-to-date? Whatever your size of operation, contact your local Case IH dealership for professional advice on finance and future-safe business investment. Case IH knows your farming needs best.

MODELS	PUMA 140	PUMA 155	PUMA 165	PUMA 180	PUMA 195	PUMA 210
ENGINE						
Number of cylinders / type	6 turbo, intercooled					
Capacity (litres)	6.75	6.75	6.75	6.75	6.75	6.75
Bore x stroke mm	104 x 132	104 x 132	104 x 132	104 x 132	104 x 132	104 x 132
Rated power ECE R120 ³⁾ (kW/hp[CV])	104 / 142	117 / 160	123 / 167	134 / 182	145 / 197	157 / 213
Rated power ECE R120 ³⁾ Power Management (kW/hp[CV])	123 / 167	123 / 167	150 / 204	160 / 218	172 / 234	175 / 238
Rated engine speed (rpm)	2200	2200	2200	2200	2200	2200
Maximum power ECE R120 ³⁾ (kW/hp[CV])	112 / 152	124 / 168	132 / 180	147 / 200	156 / 212	164 / 223
Maximum power ECE R120 ³⁾ Power Management (kW/hp[CV])	125 / 170	131 / 178	158 / 215	172 / 234	177 / 241	178 / 242
... at engine speed (rpm)	1900 - 2000	1900 - 2000	1900 - 2000	1900 - 2000	1900 - 2000	1900 - 2000
Maximum torque (Nm/rpm)	643 / 1400	690 / 1400	774 / 1400	844 / 1400	860 / 1400	866 / 1400
Maximum torque - Power Management (Nm/rpm)	678 / 1600	690 / 1400	874 / 1600	938 / 1600	965 / 1600	984 / 1600
Torque rise Standard / Power Management (%)	42 / 27	37 / 27	45 / 35	45 / 35	37 / 30	27 / 30
Fuel tank (litres)	300	300	410	410	410	410
TRANSMISSION						
18x6 Full Powershift 40kph	●	●	●	●	●	●
19x6 Full Powershift 50kph	○	○	○	○	○	○
Powershuttle	●	●	●	●	●	●
Creeper	○	○	○	○	○	○
Rear axle Diff-lock type	Multi disc wet plate with management system					
Service brake	Hydraulically operated multiple wet disc brake, self adjusting					
FOUR-WHEEL DRIVE AND STEERING						
Type	Electro-hydraulic with management system					
Front axle suspension	○	○	○ Active	○ Active	○ Active	○ Active
Steering angle (°)	55	55	55	55	55	55
Min. turning radius ¹⁾ track setting 1829mm (m)	5.45	5.45	6.1	6.1	6.1	6.1
POWER TAKE OFF						
Type	Electro-hydraulic with Auto PTO control available					
Speeds Standard / Option	540/1000 or 540/540E/1000		540E/1000 or 540/1000			
Engine speeds Standard / Option (rpm)	1969/2120 or 1969/1546/2120		1550/2178 / 1950/2178			
Shaft type	1 3/8" 21 splines / 1 3/8" 6 splines		1 3/8" 21 splines / 1 3/8" 6 splines / 1 3/4" 20 splines			
Front PTO with 1000rpm	○	○	○	○	○	○

SPECIFICATIONS

MODELS	PUMA 140	PUMA 155	PUMA 165	PUMA 180	PUMA 195	PUMA 210
HYDRAULIC SYSTEM						
Max. pump flow Standard/Optional and system type main hydraulic (l/min)	113 PFC / -	113 PFC / -	120 / 150 PFC	120 / 150 PFC	120 / 150 PFC	120 / 150 PFC
System pressure (bar)	210	210	215	215	215	215
Control type	EHC with ride control					
Max. lift capacity (kg)	8257	8257	8650	8650	8650	8650
Max. number of remote valves Standard/Multicontroller V	- / 4 electr.			4 mechan. / 4 electr.		
Max. number of mid mount valves with electronic joystick	4 electr.	4 electr.	4 electr.	4 electr.	4 electr.	4 electr.
Category type	Cat II / III	Cat II / III	Cat. III	Cat. III	Cat. III	Cat. III
Front hitch lift capacity (kg)	3568	3568	3900	3900	3900	3900
WEIGHT						
Minimum weight (kg)	5400	5600	6850	6850	6850	6850
Permissible total weight (kg)	10500	10500	12000	12000	12000	12000
Max. permissible weight front (kg)	4500	4500	5200	5200	5200	5200
Max. permissible weight rear (kg)	7300	7800	9500	9500	9500	9500
DIMENSIONS ¹⁾						
A: Total length (mm)	4449	4449	4916	4916	4916	4916
B: Total height (mm)	2985	2985	3040	3040	3100	3100
C: Total width (across rear fenders with 150mm extension) (mm)	2682	2682	2682	2682	2682	2682
D: Wheel base (mm)	2789	2789	2884	2884	2884	2884
E: Height at centre of rear axle / highest point (mm)	2180	2180	2240	2240	2240	2240
F: Track setting front (mm)	1560-2256	1560-2256	1552 - 2269	1552 - 2269	1552 - 2269	1552 - 2269
rear (mm)	1470-2294	1470-2294	1524 - 2438	1524 - 2438	1524 - 2438	1524 - 2438
STANDARD TYRES ²⁾						
Front	480/70 R28	480/70 R28	540/65 R28	540/65 R28	600/65 R28	600/65 R28
Rear	580/70 R38	580/70 R38	650/65 R38	650/65 R38	650/65 R42	650/65 R42

● Standard Equipment ○ Optional Equipment ¹⁾ With standard tyres ²⁾ Other tyres on request ³⁾ ECE R120 correspond to ISO 14396 and 97/68/EC

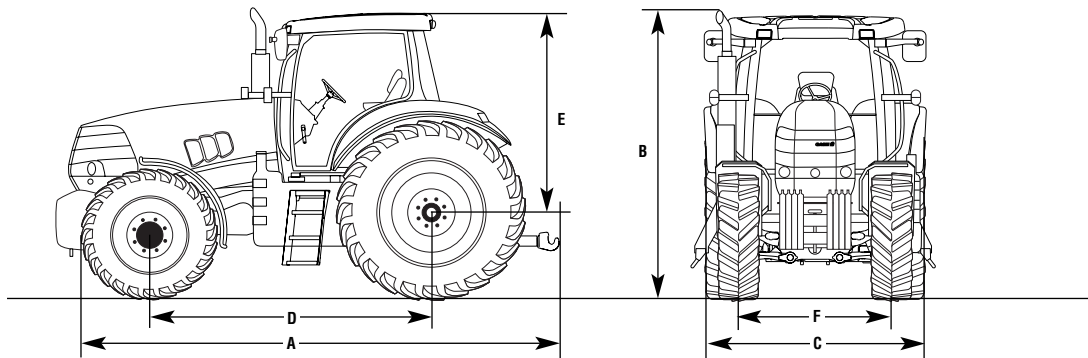

DIMENSIONS

CASE IH: FOR THOSE WHO DEMAND MORE

WWW.CASEIH.COM

 Safety never hurts! Always read the Operator's Manual before working with any equipment. Inspect equipment before using it, and be sure it is operating properly. Follow the product safety signs, and use any safety features provided.

This literature has been published for worldwide circulation. The standard and optional equipment and the availability of individual models may vary from one country to the next. Case IH reserves the right to undertake modifications without prior notice to the design and technical equipment at all times without this resulting in any obligation whatsoever to make such modifications to units already sold. Whilst every effort is made to ensure that the specifications, descriptions and illustrations in this brochure are correct at the time of going to press, these are also subject to change without prior notice. Illustrations may show optional equipment or may not show all standard equipment.

Case IH recommends **AKCELA**™ lubricants

CNH UK Ltd - Cranes Farm Road - Basildon - Essex - SS14 3AD

© 2007 CASE IH - www.caseih.com - PUMA™ SERIES-UK-BR - Free phone 0800 015 1953 (UK) or 1 800 523 128 (ROI) - Printed in Italy - 11/07 - TP01



7C0009/INB

