

5090M, 5100M, 5115M, and 5125M (FT4) Tractors Operator's Manual (North American, November 2021)



JOHN DEERE

OPERATOR'S MANUAL

5M Series Tractors (North American,
November 2021)

OMSU60197 ISSUE F3 (ENGLISH)

CALIFORNIA

Proposition 65 Warning

Diesel engine exhaust and some of its constituents are known to the State of California to cause cancer, birth defects, and other reproductive harm.

If this product contains a gasoline engine:

WARNING

The engine exhaust from this product contains chemicals known to the State of California to cause cancer, birth defects or other reproductive harm.

The State of California requires the above two warnings.

John Deere India Pvt. Ltd
North American Edition
PRINTED IN U.S.A.



* D C Y *

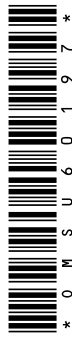

* 7 9 1 0 6 U S O M S O M S *

Introduction

Foreword

READ THIS MANUAL carefully to learn how to operate and service your machine correctly. Failure to do so could result in personal injury or equipment damage. This manual and safety signs on your machine may also be available in other languages. (See your John Deere dealer to order.)

THIS MANUAL SHOULD BE CONSIDERED a permanent part of your machine and should remain with the machine when you sell it.

MEASUREMENTS in this manual are given in both metric and customary U.S. unit equivalents. Use only correct replacement parts and fasteners. Metric and inch fasteners may require a specific metric or inch wrench.

RIGHT-HAND AND LEFT-HAND sides are determined by facing in the direction of forward travel.

WRITE PRODUCT IDENTIFICATION NUMBERS (P.I. N.) in the Specification or Identification Numbers section. Accurately record all the numbers to help in tracing the machine should it be stolen. Your dealer also needs these numbers when you order parts. File the identification numbers in a secure place off the machine.

WARRANTY is provided as part of John Deere's support program for customers who operate and maintain their equipment as described in this manual. The warranty is explained on the warranty certificate or statement which you should have received from your dealer.

This warranty provides you the assurance that John Deere will back its products where defects appear within the warranty period. In some circumstances, John Deere also provides field improvements, often without charge to the customer, even if the product is out of warranty. Should the equipment be abused, or modified to change its performance beyond the original factory specifications, the warranty will become void and field improvements may be denied. Setting fuel delivery above specifications or otherwise overpowering machines will result in such action.

THE TIRE MANUFACTURER'S warranty supplied with your machine may not apply outside the U.S.

If you are not the original owner of this machine, it is in your interest to contact your local John Deere dealer to inform them of this unit's serial number. This will help John Deere notify you of any issues or product improvements.

DX,IFC1-19-03APR09

with the instructions provided in this manual to maintain the emissions performance of the engine within the requirements applicable to the engine's category/certification.

Tampering

No deliberate tampering with or misuse of the engine emissions control system shall take place; in particular with regard to deactivating or not maintaining an exhaust gas recirculation (EGR) or a DEF dosing system. Tampering with an engine's emissions control system will void the European Union (EU) type approval and applicable emissions-related warranties.

DX,EMISSIONS,PERFORM-19-12JAN18

Emissions Performance and Tampering

Operation and Maintenance

The engine, including the emissions control system, shall be operated, used, and maintained in accordance

Contents

	Page		Page
General Information		Park Machine Safely	00A-16
Product View	00-1	Transport Tractor Safely	00A-16
Deere & Company Trademarks	00-1	Service Cooling System Safely	00A-16
Registered Trademarks	00-2	Service Accumulator Systems Safely	00A-17
Glossary of Terms	00-2	Service Tires Safely	00A-17
Regions and Country Versions	00-4	Service Front-Wheel Drive Tractor Safely	00A-17
How to Use This Manual	00-5	Tightening Wheel Retaining Bolts/Nuts	00A-17
Safety Precautions		Avoid High-Pressure Fluids	00A-18
Recognize Safety Information	00A-1	Do Not Open High-Pressure Fuel System	00A-18
Understand Signal Words	00A-1	Store Attachments Safely	00A-18
Follow Safety Instructions	00A-1	Decommissioning — Proper Recycling and Disposal of Fluids and Components	00A-18
Prepare for Emergencies	00A-1	Safety Signs	
Wear Protective Clothing	00A-2	Replace Safety Signs	00B-1
Protect Against Noise	00A-2	Operators Manual	00B-1
Handle Fuel Safely—Avoid Fires	00A-2	Use Seat Belt Properly	00B-2
Handle Starting Fluid Safely	00A-2	Instructional Seat	00B-2
Fire Prevention	00A-3	PTO Shield	00B-3
In Case of Fire	00A-3	3 Speed 540/540E/1000 PTO Shield	00B-3
Avoid Static Electricity Risk When Refueling	00A-4	Tow Implement Properly	00B-4
Keep ROPS Installed Properly	00A-4	Front End Loader	00B-4
Use Foldable ROPS and Seat Belt Properly	00A-4	Engine Coolant Heater	00B-5
Stay Clear of Rotating Drivelines	00A-5	AutoTrac Detected	00B-5
Use Steps and Handholds Correctly	00A-5	Controls and Instruments	
Read Operator's Manuals for ISOBUS Controllers	00A-6	Front Console Controls	10-1
Use Seat Belt Properly	00A-6	Foot-Operated Controls	10-1
Operating the Tractor Safely	00A-6	Console Controls	10-2
Avoid Backover Accidents	00A-7	Transmission Controls	10-3
Limited Use in Forestry Operation	00A-7	Mid-Mount SCV Joystick Controls	10-3
Operating the Loader Tractor Safely	00A-8	Rear SCV Controls	10-4
Keep Riders Off Machine	00A-8	Rear Hitch Controls	10-4
Instructional Seat	00A-8	Rear PTO Controls	10-4
Use Safety Lights and Devices	00A-9	Front PTO Controls	10-5
Use a Safety Chain	00A-9	Heat and Air Conditioning Controls	10-5
Transport Towed Equipment at Safe Speeds	00A-9	Engine Operation	
Use Caution on Slopes, Uneven Terrain, and Rough Ground	00A-10	Required Machine Stop Warning	20-1
Freeing a Mired Machine	00A-10	Engine Menu	20-1
Avoid Contact with Agricultural Chemicals	00A-11	Engine Fuel System and Power Rating	20-2
Handle Agricultural Chemicals Safely	00A-11	Check Engine Indicators and Gauges	20-3
Handling Batteries Safely	00A-12	Operate Key Switch	20-4
Avoid Heating Near Pressurized Fluid Lines	00A-13	Start Engine	20-4
Remove Paint Before Welding or Heating	00A-13	Cold Weather Start	20-5
Handle Electronic Components and Brackets Safely	00A-13	Run Engine	20-5
Practice Safe Maintenance	00A-14	Engine Speeds and Operational Procedures	20-6
Avoid Hot Exhaust	00A-14	Stop Engine	20-7
Clean Exhaust Filter Safely	00A-14	Restart Engine That Has Run Out of Fuel	20-7
Work In Ventilated Area	00A-15	Engine Block Coolant Heater	20-7
Support Machine Properly	00A-15		
Prevent Machine Runaway	00A-16		

Continued on next page

Original Instructions. All information, illustrations and specifications in this manual are based on the latest information available at the time of publication. The right is reserved to make changes at any time without notice.

COPYRIGHT © 2023
DEERE & COMPANY
Moline, Illinois
All rights reserved.
Previous Editions
Copyright © 2021,2022

Contents

	Page		Page
Air Intake, Fuel, Coolant, and Exhaust Operation		Drivetrain Operation	
Aftertreatment Indicators Overview	30-1	Drivetrain Information	50-1
Selective Catalytic Reduction (SCR) System Overview	30-3	Off Level Operation	50-1
US EPA Qualified Emergency Use — SCR Derate Override Option	30-4	Transmission Operation	
Fuel and Diesel Exhaust Fluid (DEF) Level Gauges	30-5	Transmission Menu	50A-1
Fill Fuel Tank	30-6	Transmission Settings	50A-1
Fill Diesel Exhaust Fluid (DEF) Tank	30-6	Transmission Indicators	50A-2
Reduce Fuel Consumption	30-7	16/16 Speed PowrQuad PLUS Transmission	50A-2
Engine Menu	30-7	32/16 Speed Powr8 Transmission	50A-4
Exhaust Filter Cleaning Overview	30-8	Creeper Gear Operation	50A-5
		Downhill Operation in Slippery Conditions	50A-5
		16/16 Speed Transmission Ground Speed Chart	50A-5
		32/16 Speed Transmission Ground Speed Chart	50A-6
		32/16 Speed Transmission Creeper Ground Speed Chart	50A-7
		Correction Factors for Other Tire Sizes	50A-7
Electrical and Lighting Operation		MFWD and Front Axle Operation	
Battery Disconnect Switch	40-1	Mechanical Front-Wheel Drive (MFWD On/ Auto/Brake Assist)	50B-1
Light Switch	40-2		
Headlights	40-2	Differential and Rear Axle Operation	
Loader Headlights	40-3	Differential Lock	50C-1
Bucket Lights	40-3		
Tail and Brake Lights	40-4	Power Take-Off (PTO) Operation	
Turn Signals	40-4	Match Machine Power to Implement	50D-1
Warning Lights	40-5	PTO Guard	50D-1
Beacon Light	40-6	PTO Shield	50D-1
Worklights	40-6	PTO Drive Shaft Shield	50D-1
Dome Light	40-7	Select PTO Drawbar Position	50D-2
Map Light	40-8	Exchangeable 540/10001rpm PTO Shaft	50D-3
Right-Hand Console Light	40-8	Attach PTO-Driven Implement	50D-3
Horn	40-8	Select Correct PTO Speed	50D-4
Backup Alarm	40-8	Operate Rear PTO	50D-5
Front Wiper and Washer	40-9	Operate Rear Remote PTO	50D-5
Rear Wiper and Washer	40-9	Operate Front PTO	50D-6
Radio	40-10	PTO Automatic Disengage	50D-7
Auxiliary Input and USB Port	40-10	PTO Alarm	50D-7
Bluetooth Microphone	40-10		
Speakers	40-10	Steering and Brake Operation	
Radio Antenna	40-11	Service Brakes	60-1
Satellite Module and Antenna	40-11	AutoTrac Steering System with GreenStar Display	60-1
Implement Connector	40-11	AutoTrac Basic Steering System with Front Console Display	60-2
Power Outlet	40-12	Operate Guidance Systems Safely	60-3
Convenience Outlets	40-12	Enable AutoTrac Basic	60-3
Auxiliary Power Strip	40-12	Disable AutoTrac Basic	60-4
ISO Cab Connectors	40-13	AutoTrac Resume Switch	60-4
ISOBUS Connectors	40-13	Activate AutoTrac Basic	60-5
ISOBUS Shortcut Button (ISB)	40-13	Disengage AutoTrac Basic	60-5
Service Advisor Connector	40-14	Reactivate AutoTrac Basic on Next Pass	60-5
Operator Presence	40-14	AutoTrac Basic Menu	60-6
JDLINK	40-14	AutoTrac Basic Map	60-7
		AutoTrac Status Pie	60-8
		AutoTrac Basic Track Setup	60-8
		AutoTrac Basic Track Width	60-10
		AutoTrac Basic Shift Size	60-11
		AutoTrac Basic Vehicle	60-12
		AutoTrac Basic Tuning	60-13
Displays, Software, and Electronics Operation			
Primary Display	41-1		
Information Display Navigation Controls	41-2		
Basic Menu Navigation	41-3		
Run Pages	41-4		
Layout Manager Menu	41-5		
Layout Manager Settings	41-6		
Display Settings Menu	41-6		
Display Settings	41-7		
Work Monitor Menu	41-7		
Work Monitor Operation	41-8		
Maintenance Menu	41-8		
Maintenance Counters and Intervals	41-8		

	Page		Page
StarFire Correction Mode	60-14	Adjust Flow Control	70B-8
AutoTrac Basic TCM Calibration	60-14	Power Beyond	70B-8
StarFire USB Drive	60-16	Case Drain	70B-9
StarFire GPS Status	60-17	Motor Return	70B-9
AutoTrac Basic Settings Locked	60-18	Fast Return-to-Sump	70B-9
AutoTrac Basic About	60-18	Rear SCV Oil Collection	70B-10
Autotrac Basic SF3000 Functionality	60-19		
GPS Receiver Offset Values	60-19	Wheels and Tires Operation	
AutoTrac Universal Information	60-20	Wheels and Tires Information	80-1
Hydraulics Operation		Ballasting	
Warm Transmission/Hydraulic Oil	70-1	Ballasting Information	80A-1
Open Center Hydraulics	70-1		
		Additional Equipment	
Hitch and Drawbar Operation		Tool Box	80B-1
Match Machine Power to Implement	70A-1	Front Loader	80B-1
Rear Hitch Controls	70A-1	Front Loader Suspension Activation	80B-1
Rear Hitch Components	70A-2	Lockable Fuel Fill Cap	80B-2
Operate Electrohydraulic Position Control	70A-2	Hood Latch	80B-2
Operate Electrohydraulic Draft Control	70A-4		
Operate Electrohydraulic Rate-of-Drop Control	70A-4	Operator's Station Operation	
Operate Electrohydraulic Height Limit Control	70A-5	Doors	90-1
Operate Electrohydraulic Hitch Fender Switch	70A-5	Grab Handles	90-1
Rear Hitch Menu	70A-5	Windows	90-2
Load Depth Control	70A-6	Window Shades	90-2
Implement Float	70A-7	Mirrors	90-2
Upper Limit	70A-8	Cab Seats	90-3
Drop Rate	70A-8	Adjust Seat Armrests	90-5
Raise Rate	70A-8	Instructional Seat	90-6
Manually Lower Electrohydraulic Hitch	70A-8	Steering Wheel	90-6
Prepare Implement	70A-9	Heat, Defrost, and Air Conditioning	90-6
Hitch Conversion - Category II to I	70A-9	Storage Drawer	90-8
Position Center Link	70A-10	General Storage	90-8
Adjust Lateral Float	70A-10	Field Office	90-8
Attach Implement to Rear Hitch - Ball End	70A-10	Monitor Mounts	90-9
Level Hitch - Ball End	70A-12	Rear Window Cable Routing	90-9
Attach Implement to Rear Hitch - Hook-End	70A-13	Coat Hook	90-9
Level Hitch - Hook-End	70A-15	Ash Tray and Cigarette Lighter	90-10
Adjust Hitch Side Sway	70A-16		
Quick-Coupler	70A-17	Transport and Storage	
Front Hitch Components	70A-18	Keep Machines Secure	100-1
Front Implement Connection	70A-19	Deliver Safely	100-1
Operate Front Hitch with Rear SCV Controls	70A-20	Road Transportation	100-2
Front Hitch and Coupler Operation	70A-20	Towing Loads	100-2
Drawbar Settings	70A-22	Come Home Mode	100-3
Clevis Drawbar	70A-22	Tow Machine	100-3
Drawn Implement Connection	70A-22	Front Tow Points	100-4
		Rear Tow Points	100-5
		Machine Storage	100-5
		Remove Machine from Storage	100-6
Selective Control Valve Operation		Maintenance Intervals	
Rear SCV Controls and Components	70B-1	Maintain Daily Before Start-Up	200-1
Mid-Mount SCV Controls and Components	70B-2	Maintenance Interval Chart	200-2
Connect Hydraulic Hoses	70B-3		
Connect to Rear SCVs	70B-4	Fuels, Lubricants, and Coolants	
Connect to Mid-Mount SCVs	70B-4	Alternative and Synthetic Lubricants	200A-1
Correct Reversed Cylinder Response	70B-4	Diesel Engine Coolant (engine with wet sleeve cylinder liners)	200A-1
Single-Acting Cylinders	70B-5	Operating in Warm Temperature Climates	200A-2
Implements Requiring Large Volumes of Oil	70B-5	John Deere COOL-GARD™ II Coolant Extender	200A-2
Set SCV Detents	70B-5		
Operate Hydraulic Motor with Rear SCV	70B-6		
Operate Power Beyond with Rear SCV	70B-7		
Operate Loader with Rear SCV	70B-7		

Contents

	Page		Page
Water Quality for Mixing with Coolant Concentrate	200A-2	Change Diesel Exhaust Fluid (DEF) Dosing Unit Filter	230-1
Testing Coolant Freeze Point	200A-3	Change Diesel Exhaust Fluid (DEF) Tank Header Suction Screen	230-2
Diesel Exhaust Fluid (DEF) — Use in Selective Catalytic Reduction (SCR) Equipped Engines	200A-3	Clean Diesel Exhaust Fluid (DEF) Tank	230-7
Disposal of Diesel Exhaust Fluid (DEF)	200A-4	Drain Diesel Exhaust Fluid (DEF) Tank	230-7
Refilling Diesel Exhaust Fluid (DEF) Tank	200A-4	Service Air Cleaner Elements	230-8
Storing Diesel Exhaust Fluid (DEF)	200A-4	Check and Tighten Air Intake System and Coolant System Hose Clamps	230-9
Testing Diesel Exhaust Fluid (DEF)	200A-5	Clean Air Filter Dust Unloading Valve	230-10
Diesel Engine Oil Service Interval for Operation at High Altitude	200A-5	Clean Grille Screens and Cooling Package	230-10
Diesel Engine Oil — Interim Tier 4, Final Tier 4, Stage IIIB, Stage IV, and Stage V	200A-6	Do Not Modify Fuel System	230-11
Engine Oil and Filter Service Intervals — Interim Tier 4, Final Tier 4, Stage IIIB, Stage IV, and Stage V Engines	200A-6	Drain Water and Sediment from Fuel Filter	230-11
John Deere Break-In Plus™ Engine Oil — Interim Tier 4, Final Tier 4, Stage IIIB, Stage IV, and Stage V	200A-7	Bleed Fuel System	230-12
Oil Filters	200A-7	Change Fuel Filters	230-13
Fuel Filters	200A-7	Clean Fuel Tank Vent Filter	230-14
Diesel Fuel	200A-8	Check Coolant Level	230-14
Handling and Storing Diesel Fuel	200A-8	Electrical and Lighting Maintenance	
Lubricity of Diesel Fuel	200A-9	Use Booster Battery or Charger	240-1
Testing Diesel Fuel	200A-9	Check Battery and Connections	240-1
Biodiesel Fuel	200A-9	Access and Replace Battery	240-2
Minimizing the Effect of Cold Weather on Diesel Engines	200A-10	Replace Fusible Link	240-2
Supplemental Diesel Fuel Additives	200A-11	Replace Fuses	240-3
Multipurpose Extreme Pressure (EP) Grease	200A-12	Handle Halogen Light Bulbs Safely	240-5
Mixing of Lubricants	200A-12	Replace Halogen Headlight Bulb	240-5
Lubricant Storage	200A-12	Replace LED Headlight	240-6
OilScan™ and CoolScan™	200A-12	Headlight Adjustment	240-7
Transmission, Steering, Brake, Hydraulic, and Gear Case Oil	200A-13	Replace Loader Headlight Bulb	240-7
As Required Maintenance		Replace Bucket Light	240-8
Service As Required	200B-1	Replace Tail/Turn/Brake Light Bulb	240-8
Paint and Finish Care	200B-2	Replace Warning Light Bulb	240-8
Wash Machine	200B-2	Replace Halogen Worklight Bulb	240-9
Controls and Instruments Maintenance		Replace LED Worklight	240-9
General Controls and Instruments Maintenance	210-1	Replace LED Beacon Light	240-10
Engine Maintenance		Replace Dome Light Bulb	240-10
Break-In Maintenance	220-1	Replace Map Light Bulb	240-10
Break-In Checks	220-1	Replace Right-Hand Console Light Bulb	240-11
Check Engine Oil Level	220-1	Drivetrain Maintenance	
Change Engine Oil and Filter	220-2	Drivetrain Information	250-1
Clean Open Crankcase Vent	220-3	Transmission Maintenance	
Change Open Crankcase Ventilation Filter	220-3	Change Transmission/Hydraulic Oil and Filter	250A-1
Check Fan Belt Tensioner	220-3	Check Neutral Start System	250A-1
Change Fan Belt	220-4	Check Transmission Park System	250A-1
Adjust Engine Valve Clearance	220-5	Change Transmission Dampener	250A-2
Air, Fuel, Coolant, and Exhaust Maintenance		MFWD and Front Axle Maintenance	
Required Emission-Related Information	230-1	Lubricate MFWD Axle Trunnion	250B-1
Recommended Dealer Performed Service	230-1	Change MFWD Axle Wheel Hub Oil	250B-1
Check Engine and Exhaust Compartments for Debris	230-1	Change MFWD Axle Housing Oil	250B-2
Clean Diesel Particulate Filter (DPF)	230-1	Differential and Rear Axle Maintenance	
		Lubricate Rear Axle Bearings	250C-1
		Power Take-Off (PTO) Maintenance	
		Adjust PTO Speed Shift Lever	250D-1
		Lubricate Exchangeable 540/1000 rpm PTO Shaft (If Equipped)	250D-1
		Change Front PTO Oil	250D-1

Contents

	Page		Page
Steering and Brake Maintenance		Check Air Conditioning System	290-1
Check Manual Brakes	260-1	Change Wiper Blade	290-2
Hydraulics Maintenance		Check Seat Belts	290-2
Check Transmission/Hydraulic System Oil		Keep Cab Protection System Installed	
Level	270-1	Properly	290-2
Change Transmission/Hydraulic Filter	270-1	StarFire Receiver Mount	290-3
Change Transmission/Hydraulic Oil and		Troubleshooting	
Filter	270-2	Engine	300-1
Hitch and Drawbar Maintenance		Heat and Air Conditioning	300-5
Lubricate Draft Sensing Shaft Seal	270A-1	Electrical	300-8
Lubricate Rear Hitch	270A-1	Transmission	300-9
Lubricate Front Hitch	270A-2	Brakes	300-10
Check Hitch and Drawbar for Excessive		Hydraulics	300-10
Wear	270A-2	Hitch	300-11
Selective Control Valve Maintenance		Selective Control Valves (SCV)	300-12
Adjust Mechanical SCV Cables	270B-1	On-Board Diagnostics	
Empty Rear SCV Oil Collection Bottle	270B-1	STOP, Service, Information Alert Indicators,	
Wheels and Tires Maintenance		and Alarms	300A-1
Inspect Tires	280-1	Diagnostics Menu	300A-2
Adjust and Check Clearance	280-1	Diagnostic Trouble Codes	300A-2
Check Tire Inflation Pressure	280-1	Addresses	300A-3
Tire Pressures	280-1	CAN Bus	300A-4
Tire Inflation Pressure Guidelines	280-2	Specifications	
Tire Sidewall Information	280-2	Metric Bolt and Screw Torque Values	400-1
Use Correct Tire Combinations	280-3	Unified Inch Bolt and Screw Torque Values	400-2
Correct Tire Selection	280-3	Fluid Capacities	400-3
Changing Tire Sizes	280-4	Machine Dimensions	400-3
Select Front Tire Rolling Direction	280-4	Machine Weight	400-4
Dual Wheel Usage	280-4	Engine and PTO Power	400-4
Rear Wheel Tread Width Limitations	280-5	Engine Specifications	400-4
Set Tread—Two-Position MFWD Wheels	280-5	Electrical Specifications	400-5
Set Tread—Multi-Position MFWD Wheels	280-6	PTO Engine Speeds	400-5
Set Tread—Multi-Position Rear Wheels	280-8	Hydraulics Specifications	400-5
Tighten Wheel Bolts Correctly	280-10	Rear Hitch Lift Capacities	400-5
Install Wheel Spacer	280-10	Front Hitch Lift Capacities	400-6
Tighten Wheel Bolts—MFWD Axle	280-11	Drawbar Capacities	400-6
Tighten Wheel Bolts—Rear Axle	280-11	Weight Distribution	400-6
Jacking Up Machine	280-12	Permissible Load	400-6
Check Toe-In—MFWD Axle	280-13	Ballast Capacities	400-7
Adjust Toe-In—MFWD Axle	280-13	Sound Level	400-7
Set Steering Stops	280-13	Identification Numbers	
Ballasting Maintenance		Record Product Identification Number	400A-1
General Ballast Information	280A-1	Record Front Axle Serial Number	400A-1
Select Ballast Carefully	280A-1	Record Engine Serial Number	400A-2
Front-End Ballast	280A-2	Record Transmission Serial Number	400A-2
Rear Wheel Ballast	280A-3	Record Cab Serial Number	400A-2
Control Power Hop - MFWD	280A-3	Keep Proof of Ownership	400A-3
Add Liquid Ballast to Tires	280A-4	Certification and Warranty	
Remove Liquid Ballast from Tires	280A-4	Cab ROPS Certificate	400B-1
Measure Wheel Slip	280A-4	Limited Battery Warranty	400B-1
Additional Equipment Maintenance		Emissions Control System Certification Label ..	400B-2
Front Loader Bracket Installation	280B-1	Carbon Dioxide Emissions (CO ₂)	400B-3
Set Pivoting Fender Brackets	280B-2	CARB Non-road Emissions Control Warranty	
Set Fender Position	280B-2	Statement—Compression Ignition	400B-3
Operator's Station Maintenance		EPA Non-road Emissions Control Warranty	
Clean Cab Air Filters	290-1	Statement—Compression Ignition	400B-11

Page

Maintenance Records

Daily or Every 10 Hours	500-1
Weekly or Every 50 Hours	500-2
First 100 Hours	500-3
Every 250 Hours	500-3
Every 500 Hours	500-5
Every 1000 Hours or Annually	500-6
Every 1500 Hours	500-7
Every 3000 Hours or 3 Years	500-7
Every 4500 Hours or 5 Years	500-8
Every 6000 Hours or 6 Years	500-8
Change of Ownership	500-9
Change of Ownership	500-9
Change of Ownership	500-9

General Information

Product View



Cab Machine

RXA0152060—UN—11MAY16

HV12280,000096C-19-11FEB21

Deere & Company Trademarks

NOTE: The following are trademarks of Deere & Company.

AutoClutch	Hy-Gard
AutoTrac	iTEC
Bio Hy-Gard	JDLINK
Break-In	Oilscan
CommandQuad	Plus-50
Command8	Powr8
CommandARM	PowrQuad
Cool-Gard	PowrReverser
CoolScan	PowerTech
Deere & Company	Quik-Tatch
Efficiency Manager	SeedStar
Field Cruise	Service ADVISOR
Field Office	SERVICEGARD
Grease-Gard	StarFire
GreenStar	

D3K5H22,00005E9-19-04MAY21

General Information

Registered Trademarks

*Bluetooth is a trademark of Bluetooth SIG
Teflon is a trademark of DuPont Co.*

Bluetooth®
Teflon®

DP51502.0000FBC-19-26JUL21

Glossary of Terms

ITEM	ABBREVIATION	DESCRIPTION
Air Conditioning	A/C	System used for cooling the air in the cab
Alternating Current	AC	Electrical current that reverses its direction at regularly recurring intervals
Accessory	ACC	Secondary electrical system
Armrest Interface Control	AIC	Electronic control unit
Agricultural Management System	AMS	Used with machine automatic guidance system
AutoTrac Universal	ATU	Automatic guidance system
Battery	Bat	A device used to furnish electrical current
Controller Area Network	CAN	A communication system linking on-board electronics
Cold Cranking Amperes	CCA	Measured capability of battery to perform during cold-weather operation
Chassis Control Unit	CCU	Electronic control unit
Counterclockwise	CCW	Direction opposite the rotation of the hands of a clock
Cab Load Center	CLC	Electronic control unit
Cab Switch Module	CSM	Electronic control unit
Clockwise	CW	Direction in which the hands of a clock rotate
Direct Current	DC	Electrical current flowing in one direction only
Diagnostic Receptacle	DR	A connection where hydraulic pressure can be measured
Engine Control Unit	ECU	Electronic control unit
Economic Commission for Europe	ECE	Abbreviation
Electrohydraulic	EH	Hydraulic valve function that is controlled electrically
Engine Interface Control	EIC	Electronic Control Unit
Electronic Components Relay	ELX	Relay powering most of the electronic components
Front Console Control	FCC	Electronic control unit
Forward/Neutral/Reverse	FNR	Abbreviation
Forward	FWD	Direction of movement
Gallons per Minute	gpm	Amount of fluid displaced over a period of one minute
GreenStar Display	GSD	Abbreviation
Heating, Ventilating, and Air Conditioning	HVAC	Abbreviation
Hitch Control Unit	HCC	Electronic control unit
Hitch Valve Control	HV1	Electronic control unit
Inside Diameter	ID	Abbreviation
Ignition	IGN	Control for starting and stopping the machine
International Standards Organization	ISO	Standards organization
JDLINK Control Unit	JDL	Electronic control unit
Joint Industry Council Organization	JIC	Standards organization
Left-Hand	LH	Abbreviation
Liquid Crystal Display	LCD	A technology used for displaying information
Mechanical	Mech	Abbreviation
Mechanical Front-Wheel Drive	MFWD	A mechanically powered front axle
Multi-Function Control	MFC	Electronic control unit
Negative	Neg (—)	Electrical ground circuit
Number	No.	Abbreviation
Open Center Hydraulics	OC	Abbreviation
Outside Diameter	OD	Abbreviation

General Information

ITEM	ABBREVIATION	DESCRIPTION
Original Equipment Manufacturer	OEM	Abbreviation
Operator Interface Control	OIC	Electronic control unit
O-ring Face Seal	ORFS or ORS	A type of seal used in hydraulic connections
Primary Display Unit	PDU	Electronic control unit
Product Identification Number	PIN	Serial number relating to machine identification
Positive	Pos (+)	Charged part of an electrical circuit
Front PTO Control	PTF	Electronic Control Unit
Power Take-Off	PTO	Abbreviation
PowerTech E	PTE	Electronically controlled fuel injection
Power Transmission Utility	PTU	Electronic control unit
Reverse	Rev	Direction of movement
Right-Hand	RH	Abbreviation
Revolutions per Minute	rpm	Abbreviation
Rear PTO Control	RPT	Electronic control unit
Society of Automotive Engineers	SAE	Engineering Standards Organization
Selective Control Valve	SCV	Device used to control remote hydraulic functions
SCV Sequence Control	SMB	Electronic control unit
Slow Moving Vehicle	SMV	Warning sign on the rear of the machine
Specification	Spec	Abbreviation
Tachometer	Tach	Abbreviation
Temperature	Temp	Abbreviation
Transmission Interface Utility	TIU	Electronic control unit
Transmission	Trans	Abbreviation
Voltage (Volts)	V	Abbreviation
Vehicle Load Center	VLC	Electronic control unit
Virtual Terminal Vehicle	VTV	Electronic control unit
Without	W/O	Abbreviation
Wide-Open Throttle	WOT	Full throttle
AutoTrac Main Control	XMC	Electronic control unit
AutoTrac Supervisor Control	XSC	Electronic control unit

GS25068.0001710-19-21JUN21

Regions and Country Versions

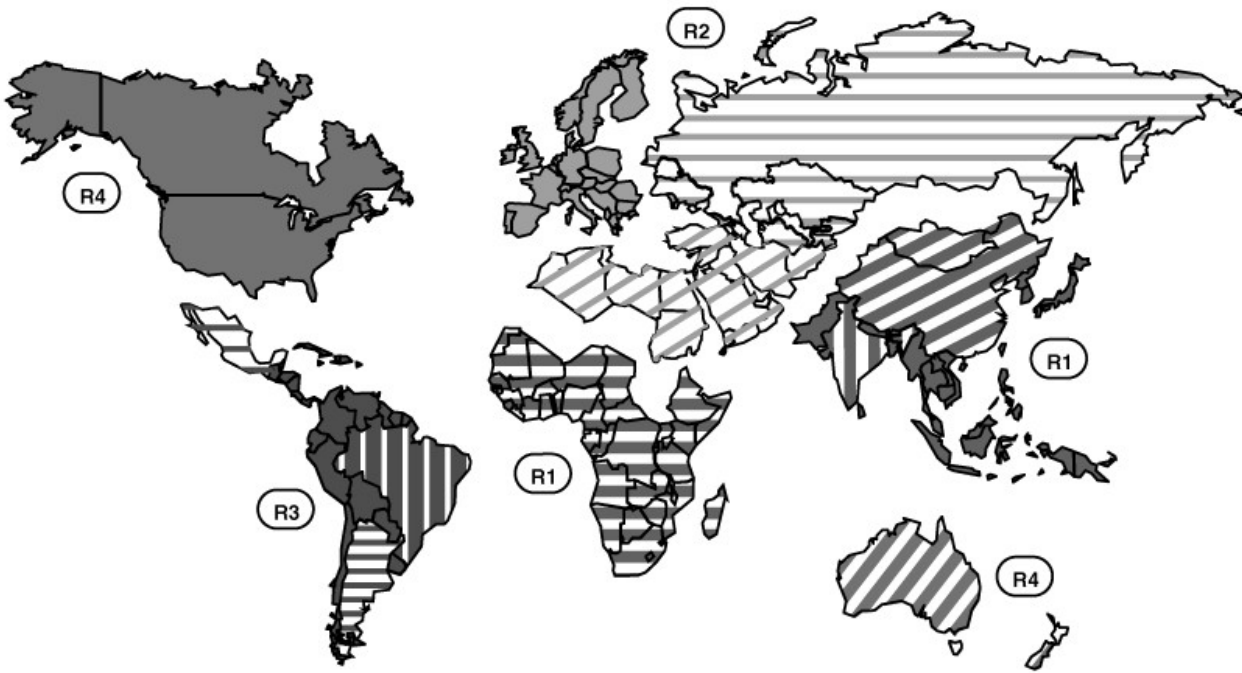

RXA0150915—UN—01FEB16

R1—Asia and Sub-Saharan Africa
R1A—Far East, Sri Lanka, and Pakistan
R1B—China
R1C—India
R1D—Sub-Saharan Africa
R2—Europe, North Africa, Mid East, CIS
R2A—European Union (EU 28+)
R2B—North Africa and North Middle East (NANME)
R2C—Common Wealth of Independent States (CIS)

R3—Central and South America
R3A—Latin America (JDLA)
R3B—Brazil
R3C—Mexico
R3D—Argentina
R4—North America
R4A—USA and Canada
R4B—Oceania (Australia and New Zealand)

Regions 1, 2, and 3 equipment is traditionally manufactured with Economic Commission for Europe (ECE) features or systems.

Region 4 equipment is traditionally manufactured with Society of Automotive Engineers (SAE) features or systems.

Drive and signal lighting, traffic signs, safety signs, and braking features are some of the systems that differ between ECE and SAE. For example, Text-Free (pictorial only) safety signs are used for ECE while Text-with-Picture safety signs are used on SAE. Use information above, if equipment information is identified by regions, countries, trade federations, industry standards, or governmental regulations.

NOTE: Australia and New Zealand (R4B) are available as either region 4 and/or region 2 configurations, only using text-free safety signs.

GS25068,0005397-19-18SEP18

How to Use This Manual

IMPORTANT: READ THIS MANUAL carefully to learn how to operate and service your machine correctly. Failure to do so could result in personal injury or equipment damage. This manual and safety signs on your machine may also be available in other languages. (See your John Deere dealer to order.)

Review manual sections for Controls and Instruments identification, Steering and Brakes, Transmission, and Transportation before operation on the road or in the field.

Operating the Machine Introduction:

- Sit in the operator seat and fasten seat belt.
- Start engine. (See Engine Operation section.)
- Turn on lights or signals as required. (See Electrical and Lighting Operation section.)
- Operate transmission to move machine. (See Transmission Operation section.)
- Use steering and brakes as required. (See Steering and Brake Operation section.)
- Activate features and implements as required. (See Operational sections.)

Preliminary Overview

Use the following list as a reminder to inspect items before operation. Detailed operation and service information is available in the relevant Operational and Maintenance sections.

- Review manual and machine for safety information and safety signs.
- Review manual for proper operation, adjustment, and service.
- Review manual for engine and drivetrain operations. (Throttles, brakes, steering, transmission gears, MFWD, and differential lock.)
- Review manual for control devices (hitch, hydraulic, and electrical).
- Review manual for regular lubrication points and intervals.
- Check for visual signs of leaks, damage, failures, and flat tires.
- Prepare machine hardware, fuel, fluids, lubricants, air, and daily maintenance.
- Check and prepare implements or attachments according to implement or attachment Operator Manuals.

Using this Manual:

The information provided in this manual is divided into sections. The sections are organized by typical machine features or functional systems (Engine, Electrical,

Hydraulic, Transmission, and so on). These sections are identified at the top of each page. Specific information within each section is organized into modules. These modules are enclosed in boxes and the main modules are identified by a heading at the top left. Page numbers identify the section as well as the number of the page in the section.

By reviewing this manual frequently, you learn which section to turn to for specific information. For example:

- Safety information is covered at the beginning.
- Operation of all features and systems is covered in the first half of the manual.
- Maintenance intervals are in the middle of the manual.
- Maintenance of all the features and systems is covered in the second half of the manual.
- Specifications are covered at the end.

A detailed table of contents appears before Safety information and there is an alphabetical index at the very end of the manual.

The Operator's Manual content flows as sequential reading down one column of text and graphic then over to the top of the next column as shown

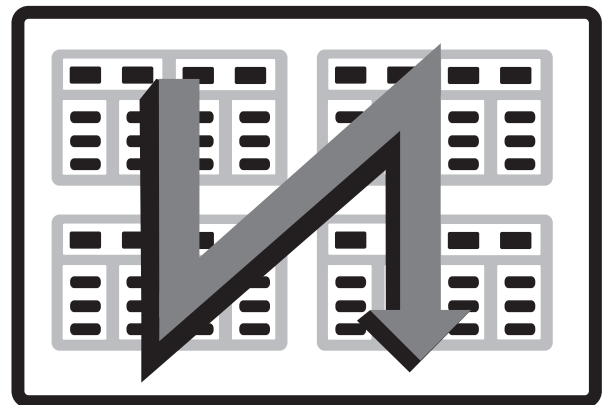

W28329—UN—18OCT17
D3K5H22,000059E-19-31MAR21

Safety Precautions

Recognize Safety Information



T81389—UN—28JUN13

This is a safety-alert symbol. When you see this symbol on your machine or in this manual, be alert to the potential for personal injury.

Follow recommended precautions and safe operating practices.

DX,ALERT-19-03OCT22

Follow Safety Instructions



TS201—UN—15APR13

Carefully read all safety messages in this manual and on your machine safety signs. Keep safety signs in good condition. Replace missing or damaged safety signs. Be sure new equipment components and repair parts include the current safety signs. Replacement safety signs are available from your John Deere dealer.

There can be additional safety information contained on parts and components sourced from suppliers that is not reproduced in this operator's manual.

Learn how to operate the machine and how to use controls properly. Do not let anyone operate without instruction.

Keep your machine in proper working condition. Unauthorized modifications to the machine may impair the function and/or safety and affect machine life.

If you do not understand any part of this manual and need assistance, contact your John Deere dealer.

DX,READ-19-01AUG22

Understand Signal Words



▲ WARNING

▲ CAUTION

TS187—19—30SEP88

DANGER; The signal word DANGER indicates a hazardous situation which, if not avoided, will result in death or serious injury.

WARNING; The signal word WARNING indicates a hazardous situation which, if not avoided, could result in death or serious injury.

CAUTION; The signal word CAUTION indicates a hazardous situation which, if not avoided, could result in minor or moderate injury. CAUTION may also be used to alert against unsafe practices associated with events which could lead to personal injury.

A signal word—DANGER, WARNING, or CAUTION—is used with the safety-alert symbol. DANGER identifies the most serious hazards. DANGER or WARNING safety signs are located near specific hazards. General precautions are listed on CAUTION safety signs. CAUTION also calls attention to safety messages in this manual.

DX,SIGNAL-19-05OCT16

Prepare for Emergencies

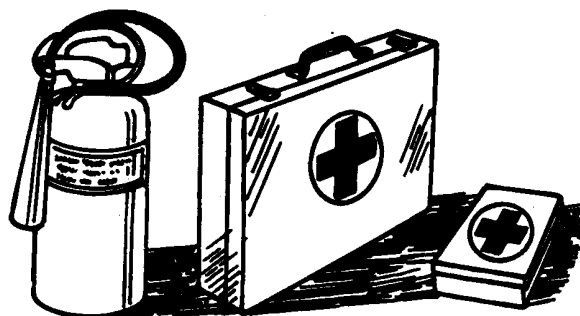

TS291—UN—15APR13

Be prepared if a fire starts.

Keep a first aid kit and fire extinguisher handy.

Keep emergency numbers for doctors, ambulance service, hospital, and fire department near your telephone.

DX,FIRE2-19-03MAR93

Wear Protective Clothing

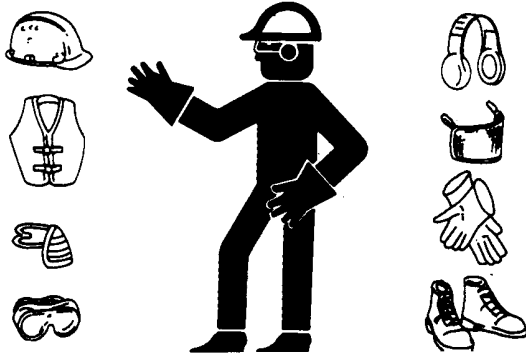

TS206—UN—15APR13

Wear close fitting clothing and safety equipment appropriate to the job.

Operating equipment safely requires the full attention of the operator. Do not wear radio or music headphones while operating machine.

DX.WEAR2-19-03MAR93

Handle Fuel Safely—Avoid Fires



TS202—UN—23AUG88

Handle fuel with care: it is highly flammable. Do not refuel the machine while smoking or when near open flame or sparks.

Always stop engine before refueling machine. Fill fuel tank outdoors.

Prevent fires by keeping machine clean of accumulated trash, grease, and debris. Always clean up spilled fuel.

Use only an approved fuel container for transporting flammable liquids.

Never fill fuel container in pickup truck with plastic bed liner. Always place fuel container on ground before refueling. Touch fuel container with fuel dispenser nozzle before removing can lid. Keep fuel dispenser nozzle in contact with fuel container inlet when filling.

Do not store fuel container where there is an open flame, spark, or pilot light such as within a water heater or other appliance.

DX.FIRE1-19-12OCT11

Protect Against Noise

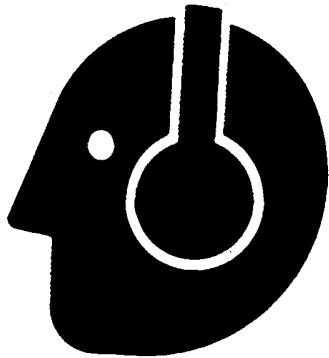

TS207—UN—23AUG88

There are many variables that affect the sound level range, including machine configuration, condition and maintenance level of the machine, ground surface, operating environmental, duty cycles, ambient noise, and attachments.

Exposure to loud noise can cause impairment or loss of hearing.

Always wear hearing protection. Wear a suitable hearing protective device such as earmuffs or earplugs to protect against objectionable or uncomfortable loud noises.

DX.NOISE-19-03OCT17

Handle Starting Fluid Safely



TS1356—UN—18MAR92

Starting fluid is highly flammable.

Keep all sparks and flame away when using it. Keep starting fluid away from batteries and cables.

To prevent accidental discharge when storing the pressurized can, keep the cap on the container, and store in a cool, protected location.

Do not incinerate or puncture a starting fluid container.

Do not use starting fluid on an engine equipped with glow plugs or an air intake heater.

DX,FIRE3-19-14MAR14

Fire Prevention

To reduce the risk of fire, your tractor should be regularly inspected and cleaned.

- Birds and other animals may build nests or bring other flammable materials into the engine compartment or onto the exhaust system. The tractor should be inspected and cleaned prior to the first use each day.
- A build up of grass, crop material and other debris may occur during normal operation. This is especially true when operating in very dry conditions or conditions where airborne crop material or crop dust is present. Any such build up must be removed to ensure proper machine function and to reduce the risk of fire. The tractor must be inspected and cleaned periodically throughout the day.
- Regular and thorough cleaning of the tractor combined with other routine maintenance procedures listed in the Operator's Manual greatly reduce the risk of fire and the chance of costly downtime.
- Do not store fuel container where there is an open flame, spark, or pilot light such as within a water heater or other appliance.
- Check fuel lines, tank, cap, and fittings frequently for damage, cracks or leaks. Replace if necessary.

Follow all operational and safety procedures posted on the machine and the Operator's Manual. Be careful of hot engine and exhaust components during inspection and cleaning. Before carrying out any inspection or cleaning, always shut OFF the engine, place the transmission in PARK or set parking brake, and remove the key. Removal of the key will prevent others from starting the tractor during inspection and cleaning.

DX,WW,TRACTOR,FIRE,PREVENTION-19-12OCT11

In Case of Fire



TS227—UN—15APR13

CAUTION: Avoid personal injury.

Stop machine immediately at the first sign of fire. Fire may be identified by the smell of smoke or sight of flames. Because fire grows and spreads rapidly, get off the machine immediately and move safely away from the fire. Do not return to the machine! The number one priority is safety.

Call the fire department. A portable fire extinguisher can put out a small fire or contain it until the fire department arrives; but portable extinguishers have limitations. Always put the safety of the operator and bystanders first. If attempting to extinguish a fire, keep your back to the wind with an unobstructed escape path so you can move away quickly if the fire cannot be extinguished.

Read the fire extinguisher instructions and become familiar with their location, parts, and operation before a fire starts. Local fire departments or fire equipment distributors may offer fire extinguisher training and recommendations.

If your extinguisher does not have instructions, follow these general guidelines:

1. Pull the pin. Hold the extinguisher with the nozzle pointing away from you, and release the locking mechanism.
2. Aim low. Point the extinguisher at the base of the fire.
3. Squeeze the lever slowly and evenly.
4. Sweep the nozzle from side-to-side.

DX,FIRE4-19-22AUG13

Avoid Static Electricity Risk When Refueling



RG22142—UN—17MAR14

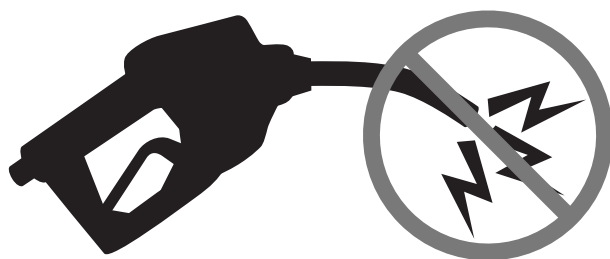

RG21992—UN—21AUG13

The removal of sulfur and other compounds in Ultra-Low Sulfur Diesel (ULSD) fuel decreases its conductivity and increases its ability to store a static charge.

Refineries may have treated the fuel with a static dissipating additive. However, there are many factors that can reduce the effectiveness of the additive over time.

Static charges can build up in ULSD fuel while it is flowing through fuel delivery systems. Static electricity discharge when combustible vapors are present could result in a fire or explosion.

Therefore, it is important to ensure that the entire system used to refuel your machine (fuel supply tank, transfer pump, transfer hose, nozzle, and others) is properly grounded and bonded. Consult with your fuel or fuel system supplier to ensure that the delivery system is in compliance with fueling standards for proper grounding and bonding practices.

DX,FUEL,STATIC,ELEC-19-12JUL13

Keep ROPS Installed Properly

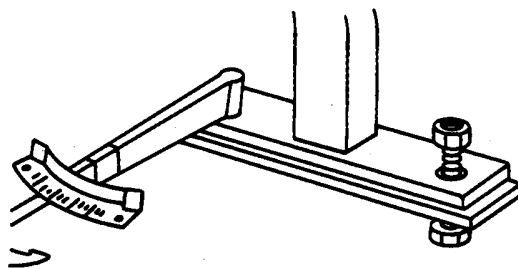

TS212—UN—23AUG88

Make certain all parts are reinstalled correctly if the roll-over protective structure (ROPS) is loosened or removed for any reason. Tighten mounting bolts to proper torque.

The protection offered by ROPS will be impaired if ROPS is subjected to structural damage, is involved in an overturn incident, or is in any way altered by welding, bending, drilling, or cutting. A damaged ROPS should be replaced, not reused.

The seat is part of the ROPS safety zone. Replace only with John Deere seat approved for your tractor.

Any alteration of the ROPS must be approved by the manufacturer.

DX,ROPS3-19-12OCT11

Use Foldable ROPS and Seat Belt Properly

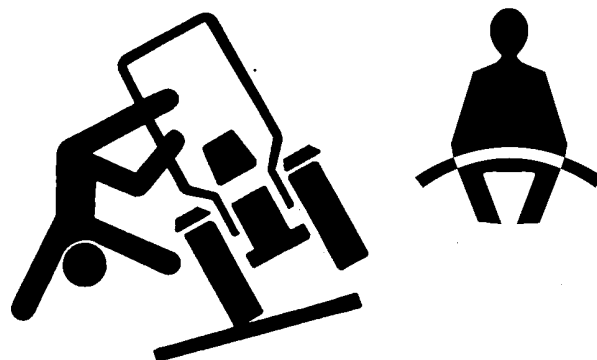

TS1729—UN—24MAY13

Avoid crushing injury or death during rollover.

- If this machine is equipped with a foldable rollover protective structure (ROPS), keep the ROPS in the fully extended and locked position. USE a seat belt when you operate with a ROPS in the fully extended position.
 - Hold the latch and pull the seat belt across the body.
 - Insert the latch into the buckle. Listen for a click.
 - Tug on the seat belt to make sure that the belt is securely fastened.

Safety Precautions

- Snug the seat belt across the hips.
- If this machine is operated with the ROPS folded (for example, to enter a low building), drive with extreme caution. **DO NOT USE** a seat belt with the ROPS folded.
- Return the ROPS to the raised, fully extended position as soon as the machine is operated under normal conditions.

DX,FOLDROPS-19-22AUG13

Stay Clear of Rotating Drivelines



TS1644—UN—22AUG95

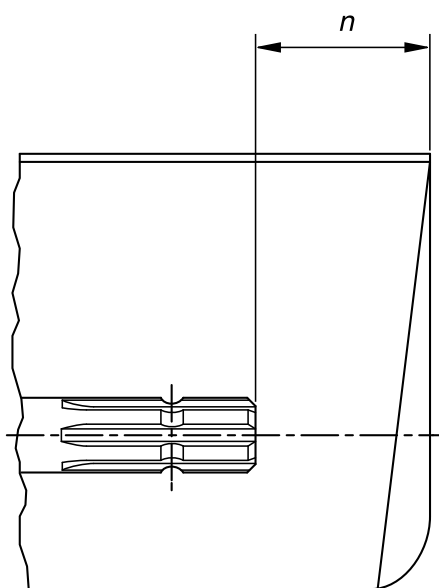

H96219—UN—29APR10

Entanglement in rotating driveline can cause serious injury or death.

Keep tractor master shield and driveline shields in place at all times. Make sure rotating shields turn freely.

Only use power take-off drivshafts with adequate guards and shields.

Wear close fitting clothing. Stop the engine and be sure that PTO driveline is stopped before making

adjustments, connections, or cleaning out PTO driven equipment.

Do not install any adapter device between the tractor and the primary implement PTO driveshaft that will allow a 1000 rpm tractor shaft to power a 540 rpm implement at speeds higher than 540 rpm.

Do not install any adapter device that results in a portion of the rotating implement shaft, tractor shaft, or the adapter to be unguarded. The tractor master shield shall overlap the end of the splined shaft and the added adaptor device as outlined in the table.

The angle at which the primary implement PTO driveshaft can be inclined may be reduced depending on the shape and size of the tractor master shield and the shape and size of the guard of the primary implement PTO driveshaft.

Do not raise implements high enough to damage the tractor master shield or guard of primary implement PTO driveshaft. Detach the PTO driveline shaft if it is necessary to increase implement height. (See Attching/ Detaching PTO Driveline)

When using Type 3/4 PTO, inclination and turning angles may be reduced depending on type of PTO master shield and coupling rails.

PTO Type	Diameter	Splines	n ± 5 mm (0.20 in.)
1	35 mm (1.378 in.)	6	85 mm (3.35 in.)
2	35 mm (1.378 in.)	21	85 mm (3.35 in.)
3	45 mm (1.772 in.)	20	100 mm (4.00 in.)
4	57.5 mm (2.264 in.)	22	100 mm (4.00 in.)

DX,PTO-19-28FEB17

Use Steps and Handholds Correctly

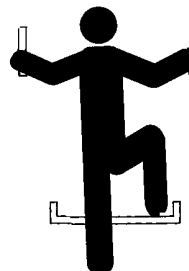

T133468—UN—15APR13

Prevent falls by facing the machine when getting on and off. Maintain 3-point contact with steps, handholds, and handrails.

Use extra care when mud, snow, or moisture present slippery conditions. Keep steps clean and free of grease

or oil. Never jump when exiting machine. Never mount or dismount a moving machine.

DX,WW,MOUNT-19-12OCT11

Read Operator's Manuals for ISOBUS Controllers

In addition to GreenStar™ Applications, this display can be used as a display device for any ISOBUS Controller that meets ISO 11783 standard. This includes capability to control ISOBUS implements. When used in this manner, information and control functions placed on the display are provided by the ISOBUS Controller and are the responsibility of the ISOBUS Controller manufacturer. Some of these functions could pose a hazard to either the operator or a bystander. Read the Operator's Manual provided by the ISOBUS Controller manufacturer and observe all safety messages in manual and on ISOBUS Controller product prior to use.

NOTE: ISOBUS refers to the ISO Standard 11783

DX,WW,ISOBUS-19-15JUL15

Use Seat Belt Properly

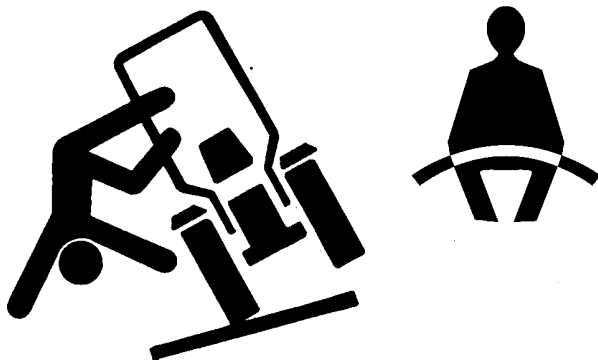

TS1729—UN—24MAY13

Avoid crushing injury or death during rollover.

This machine is equipped with a rollover protective structure (ROPS). USE a seat belt when you operate with a ROPS.

- Hold the latch and pull the seat belt across the body.
- Insert the latch into the buckle. Listen for a click.
- Tug on the seat belt latch to make sure that the belt is securely fastened.
- Snug the seat belt across the hips.

Replace entire seat belt if mounting hardware, buckle, belt, or retractor show signs of damage.

Inspect seat belt and mounting hardware at least once a year. Look for signs of loose hardware or belt damage,

GreenStar is a trademark of Deere & Company

such as cuts, fraying, extreme or unusual wear, discoloration, or abrasion. Replace only with replacement parts approved for your machine. See your John Deere dealer.

DX,ROPS1-19-22AUG13

Operating the Tractor Safely

You can reduce the risk of accidents by following these simple precautions:

- Use your tractor only for jobs it was designed to perform, for example, pushing, pulling, towing, actuating, and carrying a variety of interchangeable equipment designed to conduct agricultural work.
- Operators must be mentally and physically capable of accessing the operator's station and/or controls, and operating the machine properly and safely.
- Never operate machine when distracted, fatigued, or impaired. Proper machine operation requires the operator's full attention and awareness.
- This tractor is not intended to be used as a recreational vehicle.
- Read this operator's manual before operating the tractor and follow operating and safety instructions in the manual and on the tractor.
- Follow operation and ballasting instructions found in the operator's manual for your implements/ attachments, such as front loaders.
- Follow the instructions outlined in the operator's manual of any mounted or trailed machinery or trailer. Do not operate a combination of tractor-machine or tractor-trailer unless all instructions have been followed.
- Make sure that everyone is clear of machine, attached equipment, and work area before starting engine or operation.
- Stay clear of the three-point linkage and pickup hitch (if equipped) when controlling them.
- Keep hands, feet, and clothing away from power-driven parts.

Driving Concerns

- Never get on or off a moving tractor.
- Complete any required training prior to operating vehicle.
- Keep all children and nonessential personnel off tractors and all equipment.
- Never ride on a tractor unless seated on a John Deere approved seat with a seat belt.
- Keep all shields/guards in place.
- Use appropriate visual and audible signals when operating on public roads.
- Move to side of road before stopping.
- Reduce speed when turning, applying individual

brakes, or operating around hazards on rough ground or steep slopes.

- Stability degrades when attached implements are at high position.
- Couple brake pedals together for road travel.
- Pump brakes when stopping on slippery surfaces.
- Regularly clean fenders and fender valances (mud flaps) if installed. Remove dirt before driving on public roadways.

Heated and Ventilated Operator's Seat

- An overheated seat heater can cause a burn injury or damage to the seat. To reduce the risk of burns, use caution when using the seat heater for extended periods of time, especially if the operator cannot feel temperature change or pain to the skin. Do not place objects on the seat, such as a blanket, cushion, cover, or similar item, which can cause the seat heater to overheat.

Towing Loads

- Be careful when towing and stopping heavy loads. Stopping distance increases with speed and weight of towed loads, and on slopes. Towed loads with or without brakes that are too heavy for the tractor or are towed too fast can cause loss of control.
- Consider the total weight of the equipment and its load.
- Hitch towed loads only to approved couplings to avoid rearward upset.

Parking and Leaving the Tractor

- Before dismounting, shut off SCVs, disengage PTO, stop engine, lower implements/attachments to ground, place implement/attachment control devices in neutral, and securely engage park mechanism, including the park pawl and park brake. In addition, if the tractor is left unattended, remove key.
- Leaving transmission in gear with engine off will NOT prevent the tractor from moving.
- Never go near an operating PTO or an operating implement.
- Wait for all movement to stop before servicing machinery.

Common Accidents

Unsafe operation or misuse of the tractor can result in accidents. Be alert to hazards of tractor operation.

The most common accidents involving tractors are:

- Tractor rollover
- Collisions with motor vehicles
- Improper starting procedures
- Entanglement in PTO shafts
- Falling from tractor

- Crushing and pinching during hitching

DX,WW,TRACTOR-19-08MAY19

Avoid Backover Accidents



PC10857XW—UN—15APR13

Before moving machine, be sure that all persons are clear of machine path. Turn around and look directly for best visibility. Use a signal person when backing if view is obstructed or when in close quarters.

Do not rely on a camera to determine if personnel or obstacles are behind the machine. The system can be limited by many factors including maintenance practices, environmental conditions, and operating range.

DX,AVOID,BACKOVER,ACCIDENTS-19-30AUG10

Limited Use in Forestry Operation

The intended use of John Deere tractors when used in forestry operations is limited to tractor-specific applications like transport, stationary work such as log splitting, propulsion, or operating implements with PTO, hydraulic, or electrical systems.

These are applications where normal operation does not present a risk of falling or penetrating objects. Any forestry applications beyond these applications, such as forwarding and loading, requires fitment of application-specific components including Falling Object Protective Structure (FOPS) and/or Operative Protective Structures (OPS). Contact John Deere dealer for special components.

DX,WW,FORESTRY-19-12OCT11

Operating the Loader Tractor Safely

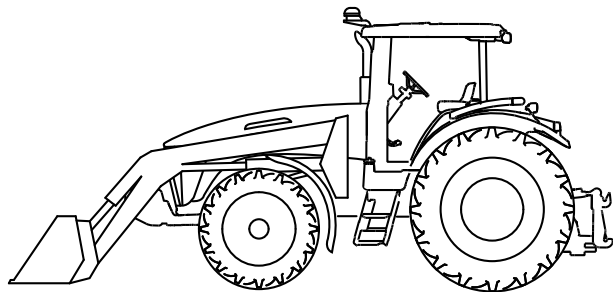

TS1692—UN—09NOV09

When operating a machine with a loader application, reduce speed as required to ensure good tractor and loader stability.

To avoid tractor rollover and damage to front tires and tractor, do not carry load with your loader at a speed over 10 km/h (6 mph).

To avoid tractor damage do not use a front loader or a sprayer tank if the tractor is equipped with a 3 Meter Front Axle.

Never allow anyone to walk or work under a raised loader.

Do not use loader as a work platform.

Do not lift or carry anyone on loader, in bucket, or on implement or attachment.

Lower loader to ground before leaving operators station.

The Rollover Protective Structure (ROPS) or cab roof, if equipped, may not provide sufficient protection from load falling onto the operators station. To prevent loads from falling onto the operators station, always use appropriate implements for specific applications (that is, manure forks, round bale forks, round bale grippers, and claspers).

Ballast tractor in accordance to Ballast Recommendations in PREPARE TRACTOR section.

DX,WW,LOADER-19-18SEP12

Keep Riders Off Machine

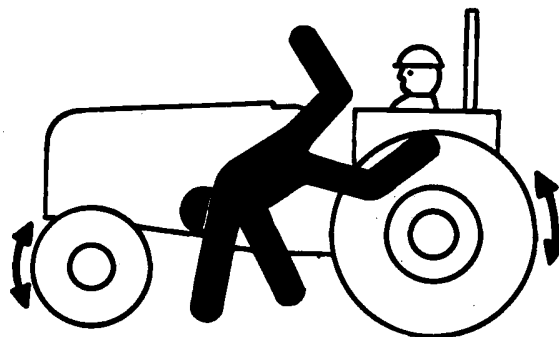

TS290—UN—23AUG88

Only allow the operator on the machine. Keep riders off.

Riders on machine are subject to injury such as being struck by foreign objects and being thrown off of the machine. Riders also obstruct the operator's view resulting in the machine being operated in an unsafe manner.

DX,RIDER-19-03MAR93

Instructional Seat



TS1730—UN—24MAY13

The instructional seat, if so equipped, has been provided only for training operators or diagnosing machine problems.

DX,SEAT,NA-19-22AUG13

Use Safety Lights and Devices

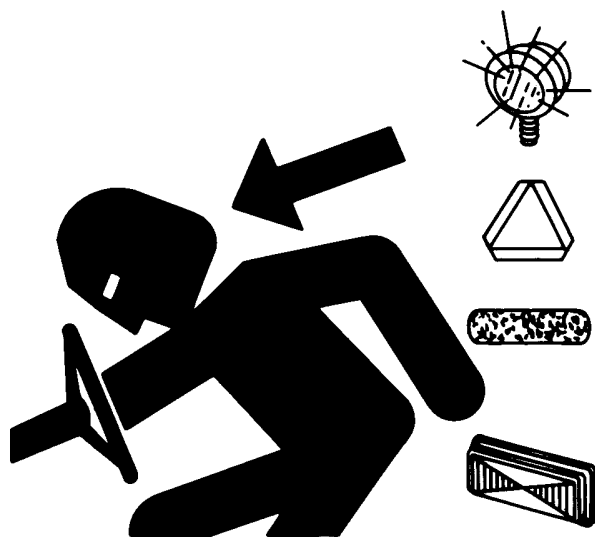

TS951—UN—12APR90

Prevent collisions between other road users, slow moving tractors with attachments or towed equipment, and self-propelled machines on public roads. Frequently check for traffic from the rear, especially in turns, and use turn signal lights.

Use headlights, flashing warning lights, and turn signals day and night. Follow local regulations for equipment lighting and marking. Keep lighting and marking visible, clean, and in good working order. Replace or repair lighting and marking that has been damaged or lost. An implement safety lighting kit is available from your John Deere dealer.

DX.FLASH-19-07JUL99

Use a Safety Chain

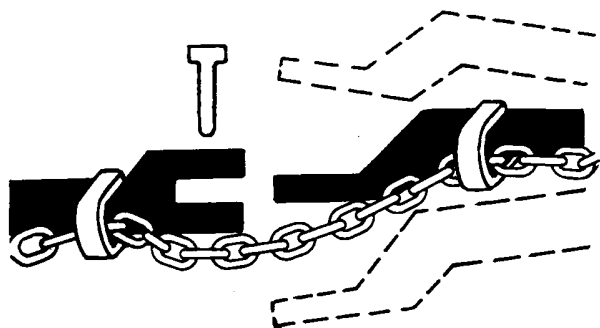

TS217—UN—23AUG88

A safety chain will help control drawn equipment should it accidentally separate from the drawbar.

Using the appropriate adapter parts, attach the chain to the tractor drawbar support or other specified anchor location. Provide only enough slack in the chain to permit turning.

See your John Deere dealer for a chain with a strength

rating equal to or greater than the gross weight of the towed machine. Do not use safety chain for towing.

DX.CHAIN-19-03MAR93

Transport Towed Equipment at Safe Speeds

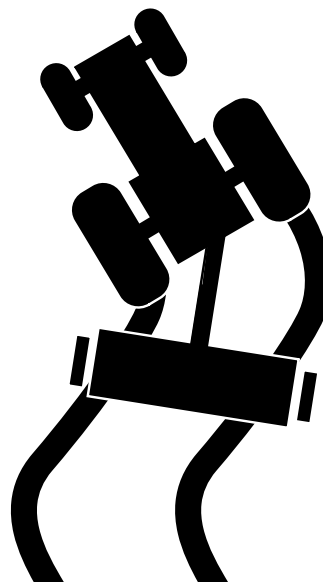

TS1686—UN—27SEP06

Do not exceed the maximum transport speed. This towing unit may be capable of operating at transport speeds that exceed the maximum allowable transport speed for towed implements.

Before transporting a towed implement, determine from signs on the implement or information provided in the implement's operator manual the maximum transport speed. Never transport at speeds that exceed the implement's maximum transport speed. Exceeding the implement's maximum transport speed can result in:

- Loss of control of the towing unit/implement combination
- Reduced or no ability to stop during braking
- Implement tire failure
- Damage to the implement structure or its components

Implements shall be equipped with brakes if the maximum fully loaded weight is greater than 1500 kg (3307 lbs) and greater than 1.5 times the weight of the towing unit.

Example: Implement mass is 1600 kg (3527 lbs) and towing unit mass is 1600 kg (3527 lbs), example implement is not required to have brakes.

Implements without brakes: Do not transport at speeds greater than 32 km/h (20 mph).

Implements with brakes:

Safety Precautions

- If the manufacturer does not specify a maximum transport speed, do not tow at speeds greater than 40 km/h (25 mph).
- When transporting at speeds up to 40 km/h (25 mph) the fully loaded implement must weigh less than 4.5 times the towing unit weight.
- When transporting at speeds between 40—50 km/h (25—31 mph) the fully loaded implement must weigh less than 3.0 times the towing unit weight.

When towing a trailer, become familiar with the braking characteristics and ensure the compatibility of the tractor/trailer combination in regard to the deceleration rate.

DX,TOW1-19-28FEB17

Use Caution on Slopes, Uneven Terrain, and Rough Ground

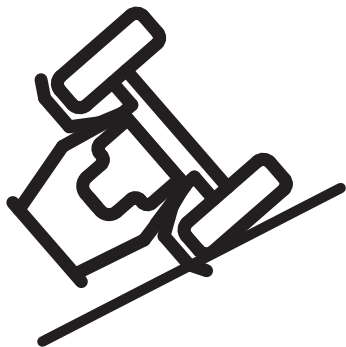

RXA0103437—UN—01JUL09

Avoid holes, ditches, and obstructions which cause the tractor to tip, especially on slopes. Avoid sharp uphill turns.

Driving forward out of a ditch, mired condition, or up a steep slope could cause the tractor to tip over rearward. Back out of these situations if possible.

Danger of overturn increases greatly with narrow tread setting, at high speed.

Not all conditions that can cause a tractor to overturn are listed. Be alert for any situation in which stability may be compromised.

Slopes are a major factor related to loss-of-control and tip-over accidents, which can result in severe injury or death. Operation on all slopes requires extra caution.

Uneven terrain or rough ground can cause loss-of-control and tip-over accidents, which can result in severe injury or death. Operation on uneven terrain or rough ground requires extra caution.

Never drive near the edge of a gully, drop-off, ditch, steep embankment, or a body of water. The machine could suddenly roll over if a wheel goes over the edge or the ground caves in

Choose a low ground speed so you will not have to stop or shift while on a slope.

Avoid starting, stopping, or turning on a slope. If the tires lose traction, disengage the PTO and proceed slowly, straight down the slope.

Keep all movement on slopes slow and gradual. Do not make sudden changes in speed or direction, which could cause the machine to roll over.

DX,WW,SLOPE-19-28FEB17

Freeing a Mired Machine

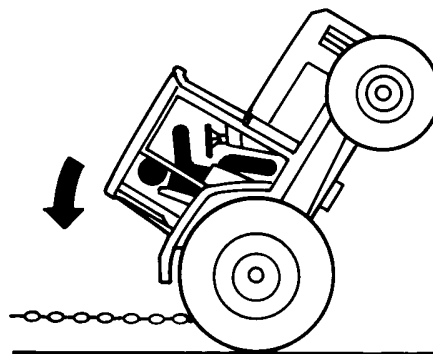

TS1645—UN—15SEP95



TS263—UN—23AUG88

Attempting to free a mired machine can involve safety hazards such as the mired tractor tipping rearward, the towing tractor overturning, and the tow chain or tow bar (a cable is not recommended) failing and recoiling from its stretched condition.

Back your tractor out if it gets mired down in mud. Unhitch any towed implements. Dig mud from behind the rear wheels. Place boards behind the wheels to provide a solid base and try to back out slowly. If necessary, dig mud from the front of all wheels and drive slowly ahead.

If necessary to tow with another unit, use a tow bar or a long chain (a cable is not recommended). Inspect the chain for flaws. Make sure all parts of towing devices are of adequate size and strong enough to handle the load.

Always hitch to the drawbar of the towing unit. Do not

hitch to the front pushbar attachment point. Before moving, clear the area of people. Apply power smoothly to take up the slack: a sudden pull could snap any towing device causing it to whip or recoil dangerously.

DX,MIREd-19-07,JUL99

Avoid Contact with Agricultural Chemicals

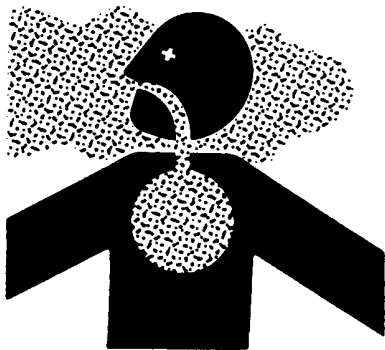

TS220—UN—15APR13



TS272—UN—23AUG88

This enclosed cab does not protect against inhaling vapor, aerosol or dust. If pesticide use instructions require respiratory protection, wear an appropriate respirator inside the cab.

Before leaving the cab, wear personal protective equipment as required by the pesticide use instructions. When re-entering the cab, remove protective equipment and store either outside the cab in a closed box or some other type of sealable container or inside the cab in a pesticide resistant container, such as a plastic bag.

Clean your shoes or boots to remove soil or other contaminated particles prior to entering the cab.

DX,CABS-19-25MAR09

Handle Agricultural Chemicals Safely



TS220—UN—15APR13

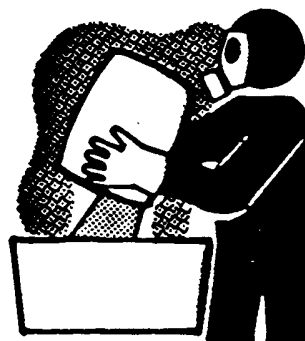

A34471

A34471—UN—11OCT88

Chemicals used in agricultural applications such as fungicides, herbicides, insecticides, pesticides, rodenticides, and fertilizers can be harmful to your health or the environment if not used carefully.

Always follow all label directions for effective, safe, and legal use of agricultural chemicals.

Reduce risk of exposure and injury:

- Wear appropriate personal protective equipment as recommended by the manufacturer. In the absence of manufacturer's instructions, follow these general guidelines:
 - Chemicals labeled **'Danger'**: Most toxic. Generally require use of goggles, respirator, gloves, and skin protection.
 - Chemicals labeled **'Warning'**: Less toxic. Generally require use of goggles, gloves, and skin protections.
 - Chemicals labeled **'Caution'**: Least toxic. Generally require use of gloves and skin protection.
- Avoid inhaling vapor, aerosol or dust.
- Always have soap, water, and towel available when working with chemicals. If chemical contacts skin, hands, or face, wash immediately with soap and water. If chemical gets into eyes, flush immediately with water.
- Wash hands and face after using chemicals and before eating, drinking, smoking, or urination.

Safety Precautions

- Do not smoke or eat while applying chemicals.
- After handling chemicals, always bathe or shower and change clothes. Wash clothing before wearing again.
- Seek medical attention immediately if illness occurs during or shortly after use of chemicals.
- Keep chemicals in original containers. Do not transfer chemicals to unmarked containers or to containers used for food or drink.
- Store chemicals in a secure, locked area away from human or livestock food. Keep children away.
- Always dispose of containers properly. Triple rinse empty containers and puncture or crush containers and dispose of properly.

DX,WW,CHEM01-19-24AUG10

Handling Batteries Safely



TS204—UN—15APR13

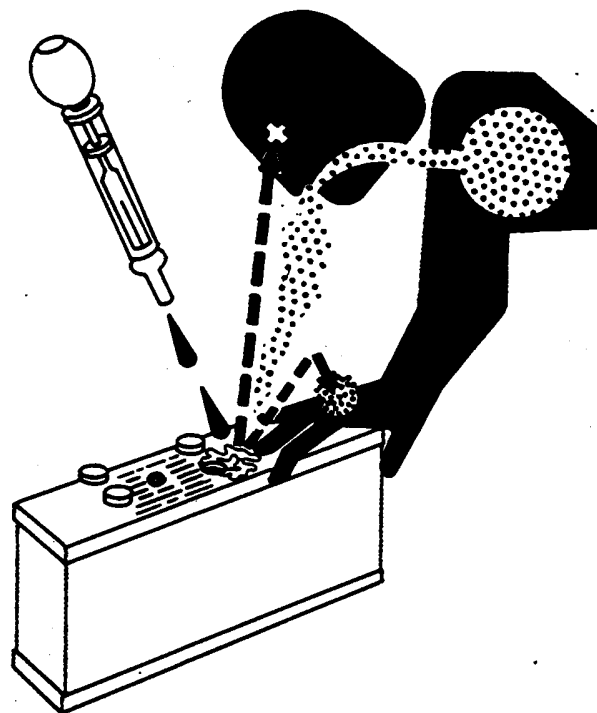

TS203—UN—23AUG88

Battery gas can explode. Keep sparks and flames away from batteries. Use a flashlight to check battery electrolyte level.

Never check battery charge by placing a metal object across the posts. Use a voltmeter or hydrometer.

Always remove grounded (-) battery clamp first and replace grounded clamp last.

Sulfuric acid in battery electrolyte is poisonous and strong enough to burn skin, eat holes in clothing, and cause blindness if splashed into eyes.

Avoid hazards by:

- Filling batteries in a well-ventilated area
- Wearing eye protection and rubber gloves
- Avoiding use of air pressure to clean batteries
- Avoiding breathing fumes when electrolyte is added
- Avoiding spilling or dripping electrolyte
- Using correct battery booster or charger procedure.

If acid is spilled on skin or in eyes:

1. Flush skin with water.
2. Apply baking soda or lime to help neutralize the acid.
3. Flush eyes with water for 15—30 minutes. Get medical attention immediately.

If acid is swallowed:

Safety Precautions

1. Do not induce vomiting.
2. Drink large amounts of water or milk, but do not exceed 2 L (2 qt.).
3. Get medical attention immediately.

WARNING: Battery posts, terminals, and related accessories contain lead and lead compounds, chemicals known to the State of California to cause cancer and reproductive harm. **Wash hands after handling.**

DX,WW,BATTERIES-19-02DEC10

Avoid Heating Near Pressurized Fluid Lines



TS953—UN—15MAY90

Flammable spray can be generated by heating near pressurized fluid lines, resulting in severe burns to yourself and bystanders. Do not heat by welding, soldering, or using a torch near pressurized fluid lines or other flammable materials. Pressurized lines can accidentally burst when heat goes beyond the immediate flame area.

DX,TORCH-19-10DEC04

Remove Paint Before Welding or Heating



TS220—UN—15APR13

Avoid potentially toxic fumes and dust.

Hazardous fumes can be generated when paint is heated by welding, soldering, or using a torch.

Remove paint before heating:

- Remove paint a minimum of 100 mm (4 in.) from area to be affected by heating. If paint cannot be removed, wear an approved respirator before heating or welding.
- If you sand or grind paint, avoid breathing the dust. Wear an approved respirator.
- If you use solvent or paint stripper, remove stripper with soap and water before welding. Remove solvent or paint stripper containers and other flammable material from area. Allow fumes to disperse at least 15 minutes before welding or heating.

Do not use a chlorinated solvent in areas where welding will take place.

Do all work in an area that is well ventilated to carry toxic fumes and dust away.

Dispose of paint and solvent properly.

DX,PAINT-19-24JUL02

Handle Electronic Components and Brackets Safely



TS249—UN—23AUG88

Falling while installing or removing electronic components mounted on equipment can cause serious injury. Use a ladder or platform to easily reach each mounting location. Use sturdy and secure footholds and handholds. Do not install or remove components in wet or icy conditions.

If installing or servicing a RTK base station on a tower or other tall structure, use a certified climber.

If installing or servicing a global positioning receiver mast used on an implement, use proper lifting techniques and wear proper protective equipment. The mast is heavy and can be awkward to handle. Two people are required when mounting locations are not accessible from the ground or from a service platform.

DX,WW,RECEIVER-19-24AUG10

Practice Safe Maintenance



TS218—UN—23AUG88

Understand service procedure before doing work. Keep area clean and dry.

Never lubricate, service, or adjust machine while it is moving. Keep hands, feet, and clothing away from power-driven parts. Disengage all power and operate controls to relieve pressure. Lower equipment to the ground. Stop the engine. Remove the key. Allow machine to cool.

Securely support any machine elements that must be raised for service work.

Keep all parts in good condition and properly installed. Fix damage immediately. Replace worn or broken parts. Remove any buildup of grease, oil, or debris.

On self-propelled equipment, disconnect battery ground cable (-) before making adjustments on electrical systems or welding on machine.

On towed implements, disconnect wiring harnesses from tractor before servicing electrical system components or welding on machine.

Falling while cleaning or working at height can cause serious injury. Use a ladder or platform to easily reach each location. Use sturdy and secure footholds and handholds.

DX,SERV-19-28FEB17

Avoid Hot Exhaust



RG17488—UN—21AUG09

Servicing machine or attachments with engine running can result in serious personal injury. Avoid exposure and skin contact with hot exhaust gases and components.

Exhaust parts and streams become very hot during operation. Exhaust gases and components reach temperatures hot enough to burn people, ignite, or melt common materials.

DX,EXHAUST-19-20AUG09

Clean Exhaust Filter Safely



TS227—UN—15APR13

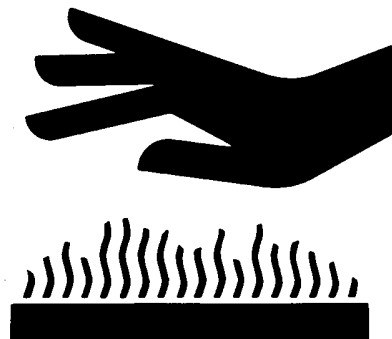

TS271—UN—23AUG88

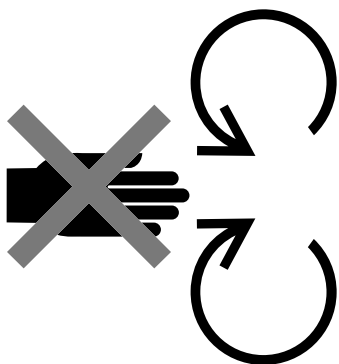

TS1693—UN—09DEC09



TS1695—UN—07DEC09

During exhaust filter cleaning operations, the engine may run at elevated idle and hot temperatures for an extended period of time. Exhaust gases and exhaust filter components reach temperatures hot enough to burn people, or ignite or melt common materials.

Keep machine away from people, animals, or structures which may be susceptible to harm or damage from hot exhaust gases or components. Avoid potential fire or explosion hazards from flammable materials and vapors near the exhaust. Keep exhaust outlet away from people and anything that can melt, burn, or explode.

Closely monitor machine and surrounding area for smoldering debris during and after exhaust filter cleaning.

Adding fuel while an engine is running can create a fire or explosion hazard. Always stop engine before refueling machine and clean up any spilled fuel.

Always make sure that engine is stopped while hauling machine on a truck or trailer.

Contact with exhaust components while still hot can result in serious personal injury.

Avoid contact with these components until cooled to safe temperatures.

If service procedure requires engine to be running:

- Only engage power-driven parts required by service procedure
- Ensure that other people are clear of operator station and machine

Keep hands, feet, and clothing away from power-driven parts.

Always disable movement (neutral), set the parking brake or mechanism and disconnect power to attachments or tools before leaving the operator's station.

Shut off engine and remove key (if equipped) before leaving the machine unattended.

DX,EXHAUST,FILTER-19-12JAN11

Work In Ventilated Area



TS220—UN—15APR13

Engine exhaust fumes can cause sickness or death. If it is necessary to run an engine in an enclosed area, remove the exhaust fumes from the area with an exhaust pipe extension.

If you do not have an exhaust pipe extension, open the doors and get outside air into the area.

DX,AIR-19-17FEB99

Support Machine Properly

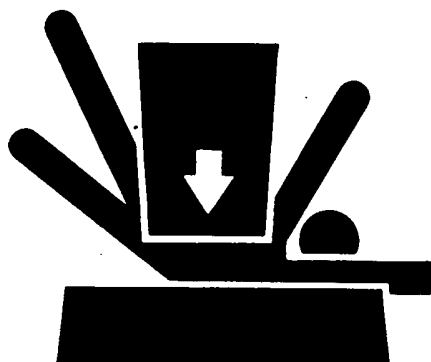

TS229—UN—23AUG88

Always lower the attachment or implement to the ground before you work on the machine. If the work requires that the machine or attachment be lifted, provide secure support for them. If left in a raised position, hydraulically supported devices can settle or leak down.

Do not support the machine on cinder blocks, hollow tiles, or props that may crumble under continuous load.

Do not work under a machine that is supported solely by a jack. Follow recommended procedures in this manual.

When implements or attachments are used with a machine, always follow safety precautions listed in the implement or attachment operator's manual.

DX,LOWER-19-24FEB00

Prevent Machine Runaway



TS177—UN—11JAN89

Avoid possible injury or death from machinery runaway.

Do not start engine by shorting across starter terminals. Machine will start in gear if normal circuitry is bypassed.

NEVER start engine while standing on ground. Start engine only from operator's seat, with transmission in neutral or park.

DX,BYPAS1-19-29SEP98

Park Machine Safely

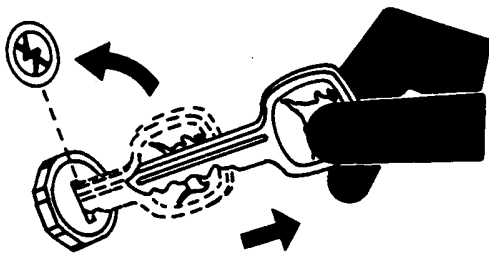

TS230—UN—24MAY89

Before working on the machine:

- Lower all equipment to the ground.
- Stop the engine and remove the key.
- Disconnect the battery ground strap.
- Hang a "DO NOT OPERATE" tag in operator station.

DX,PARK-19-04JUN90

Transport Tractor Safely

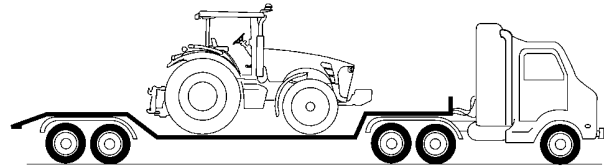

RXA0103709—UN—01JUL09

A disabled tractor is best transported on a flatbed carrier. Use chains to secure the tractor to the carrier. The axles and tractor frame are suitable attachment points.

Before transporting the tractor on a low-loader truck or flatbed rail wagon, make sure that the hood is secured over the tractor engine and that doors, roof hatch (if equipped) and windows are properly closed.

Never tow a tractor at a speed greater than 10 km/h (6 mph). An operator must steer and brake the tractor under tow.

DX,WW,TRANSPORT-19-19AUG09

Service Cooling System Safely



TS281—UN—15APR13

Explosive release of fluids from pressurized cooling system can cause serious burns.

Shut off engine. Only remove filler cap when cool enough to touch with bare hands. Slowly loosen cap to first stop to relieve pressure before removing completely.

DX,WW,COOLING-19-19AUG09

Service Accumulator Systems Safely



TS281—UN—15APR13

Escaping fluid or gas from systems with pressurized accumulators that are used in air conditioning, hydraulic, and air brake systems can cause serious injury. Extreme heat can cause the accumulator to burst, and pressurized lines can be accidentally cut. Do not weld or use a torch near a pressurized accumulator or pressurized line.

Relieve pressure from the pressurized system before removing accumulator.

Relieve pressure from the hydraulic system before removing accumulator. Never attempt to relieve hydraulic system or accumulator pressure by loosening a fitting.

Accumulators cannot be repaired.

DX,WW,ACCLA2-19-22AUG03

Service Tires Safely



RXA0103438—UN—11JUN09

Explosive separation of a tire and rim parts can cause serious injury or death.

Do not attempt to mount a tire unless you have the proper equipment and experience to perform the job.

Always maintain the correct tire pressure. Do not inflate the tires above the recommended pressure. Never weld or heat a wheel and tire assembly. The heat can cause an increase in air pressure resulting in a tire explosion. Welding can structurally weaken or deform the wheel.

When inflating tires, use a clip-on chuck and extension hose long enough to allow you to stand to one side and NOT in front of or over the tire assembly. Use a safety cage if available.

Check wheels for low pressure, cuts, bubbles, damaged rims, or missing lug bolts and nuts.

Wheels and tires are heavy. When handling wheels and tires use a safe lifting device or get an assistant to help lift, install, or remove.

DX,WW,RIMS-19-28FEB17

Service Front-Wheel Drive Tractor Safely

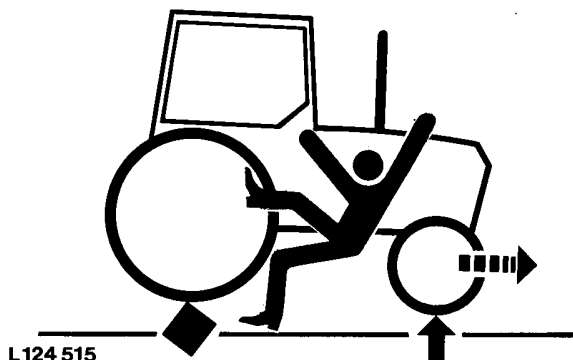

L124 515

L124515—UN—06AUG94

When servicing front-wheel drive tractor with the rear wheels supported off the ground and rotating wheels by engine power, always support front wheels in a similar manner. Loss of electrical power or transmission hydraulic system pressure will engage the front driving wheels, pulling the rear wheels off the support if front wheels are not raised. Under these conditions, front drive wheels can engage even with switch in disengaged position.

DX,WW,MFWD-19-19AUG09

Tightening Wheel Retaining Bolts/Nuts

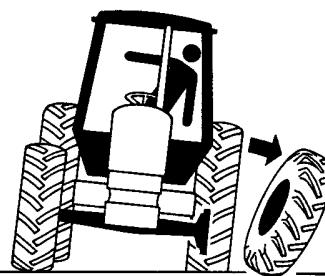

L124 516

L124516—UN—03JAN95

Torque wheel retaining bolts/nuts at the intervals specified in section Break-In Period and Service.

DX,WW,WHEEL-19-12OCT11

Avoid High-Pressure Fluids

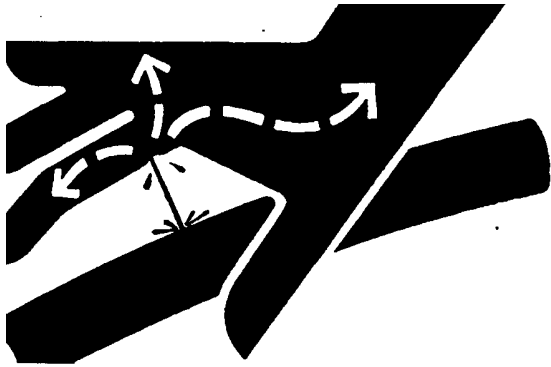

X9811—UN—23AUG88

Inspect hydraulic hoses periodically – at least once per year – for leakage, kinking, cuts, cracks, abrasion, blisters, corrosion, exposed wire braid or any other signs of wear or damage.

Replace worn or damaged hose assemblies immediately with John Deere approved replacement parts.

Escaping fluid under pressure can penetrate the skin causing serious injury.

Avoid the hazard by relieving pressure before disconnecting hydraulic or other lines. Tighten all connections before applying pressure.

Search for leaks with a piece of cardboard. Protect hands and body from high-pressure fluids.

If an accident occurs, see a doctor immediately. Any fluid injected into the skin must be surgically removed within a few hours or gangrene may result. Doctors unfamiliar with this type of injury should reference a knowledgeable medical source. Such information is available in English from Deere & Company Medical Department in Moline, Illinois, U.S.A., by calling 1-800-822-8262 or +1 309-748-5636.

DX,FLUID-19-12OCT11

Do Not Open High-Pressure Fuel System



TS1343—UN—18MAR92

High-pressure fluid remaining in fuel lines can cause serious injury. Do not disconnect or attempt repair of fuel

lines, sensors, or any other components between the high-pressure fuel pump and nozzles on engines with High Pressure Common Rail (HPCR) fuel system.

Only technicians familiar with this type of system can perform repairs. (See your John Deere dealer.)

DX,WV,HPCR1-19-07JAN03

Store Attachments Safely



TS219—UN—23AUG88

Stored attachments such as dual wheels, cage wheels, and loaders can fall and cause serious injury or death.

Securely store attachments and implements to prevent falling. Keep playing children and bystanders away from storage area.

DX,STORE-19-03MAR93

Decommissioning — Proper Recycling and Disposal of Fluids and Components

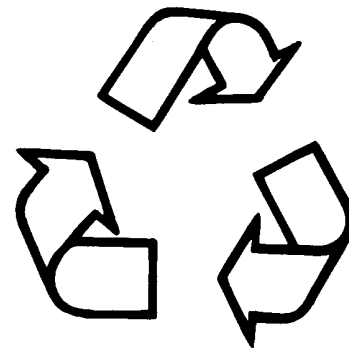

TS1133—UN—15APR13

Safety and environmental stewardship measures must be taken into account when decommissioning a machine and/or component. These measures include the following:

- Use appropriate tools and personal protective equipment such as clothing, gloves, face shields or glasses, during the removal or handling of objects and materials.
- Follow instructions for specialized components.

Safety Precautions

- Release stored energy by lowering suspended machine elements, relaxing springs, disconnecting the battery or other electrical power, and releasing pressure in hydraulic components, accumulators, and other similar systems.
- Minimize exposure to components which may have residue from agricultural chemicals, such as fertilizers and pesticides. Handle and dispose of these components appropriately.
- Carefully drain engines, fuel tanks, radiators, hydraulic cylinders, reservoirs, and lines before recycling components. Use leak-proof containers when draining fluids. Do not use food or beverage containers.
- Do not pour waste fluids onto the ground, down a drain, or into any water source.
- Observe all national, state, and local laws, regulations, or ordinances governing the handling or disposal of waste fluids (example: oil, fuel, coolant, brake fluid); filters; batteries; and, other substances or parts. Burning of flammable fluids or components in other than specially designed incinerators may be prohibited by law and could result in exposure to harmful fumes or ashes.
- Service and dispose of air conditioning systems appropriately. Government regulations may require a certified service center to recover and recycle air conditioning refrigerants which could damage the atmosphere if allowed to escape.
- Evaluate recycling options for tires, metal, plastic, glass, rubber, and electronic components which may be recyclable, in part or completely.
- Contact your local environmental or recycling center, or your John Deere dealer for information on the proper way to recycle or dispose of waste.

DX,DRAIN-19-01JUN15

Safety Signs

Replace Safety Signs



TS201—UN—15APR13

Replace missing or damaged safety signs. Use this operator's manual for correct safety sign placement.

There can be additional safety information contained on parts and components sourced from suppliers that is not reproduced in this operator's manual.

DX,SIGNS-19-18AUG09



LV14479—UN—28JUL11

Left-Hand Door Post

Operators Manual



LV5411—19—17NOV00

CAUTION

1. Read Operator's Manual before operating this tractor.
2. Keep all shields in place.
3. Hitch towed loads only to drawbar to avoid rearward upset.
4. Make certain everyone is clear of machine before starting engine or operation.
5. Keep all riders off tractor and equipment.
6. Keep hands, feet and clothing away from power-driven parts.
7. Reduce speed when turning or applying individual brakes or operating around hazards on rough ground or steep slopes.
8. Couple brake pedals together for road travel.
9. Use flashing warning lights on highway unless prohibited by law.
10. Stop engine, lower implement to ground and shift to "PARK" or set handbrake securely before dismounting.
11. Wait for all movement to stop before servicing machinery.
12. Remove key if leaving tractor unattended.

MP60050,00009C0-19-02FEB21

Use Seat Belt Properly

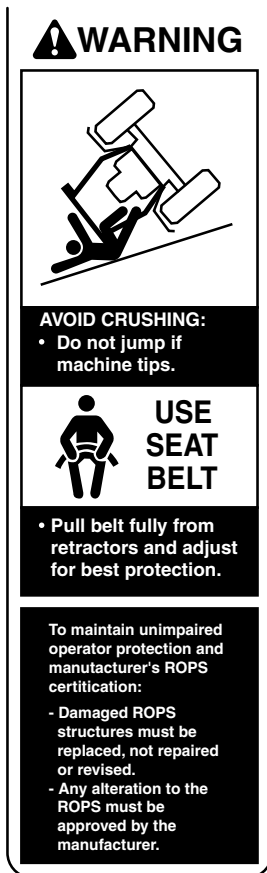

LV15901—19—25JUL12

- Pull belt fully from retractors and adjust for best protection.

To maintain unimpaired operator protection and manufacturer's ROPS certification:

- Damaged ROPS structures must be replaced, not repaired or revised.
- Any alteration to the ROPS must be approved by the manufacturer.

MP60050,00009C2-19-02FEB21

Instructional Seat



RXA0148587—19—07JUL15



LV15827—UN—22JUN12

Left-Hand Door Post



LV15838—UN—26JUN12

Left Hand Front Post

WARNING

AVOID CRUSHING:

- Do not jump if machine tips.

USE SEAT BELT

CAUTION

This instructional seat has been provided only for training operators or diagnosing machine problems.

Keep all other riders off the tractor and equipment.
Always wear your safety belt.

GS25068,0003ED5-19-07FEB18

AVOID INJURY FROM PTO

- Keep all shields in place
- Keep hands, feet and clothing away

rp32883,1675226571383-19-01MAR23

PTO Shield



RXA0148607—19—09JUL15

Warning Label

3 Speed 540/540E/1000 PTO Shield

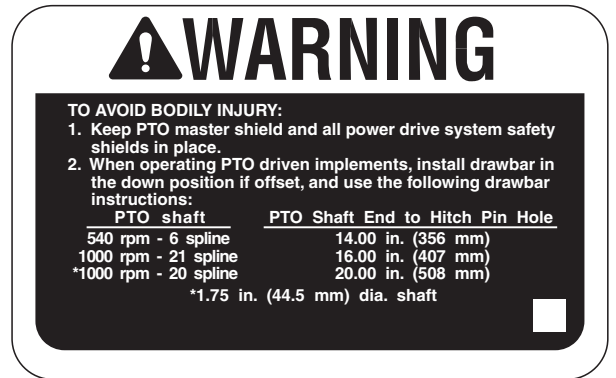

RXA0184730—UN—11AUG21

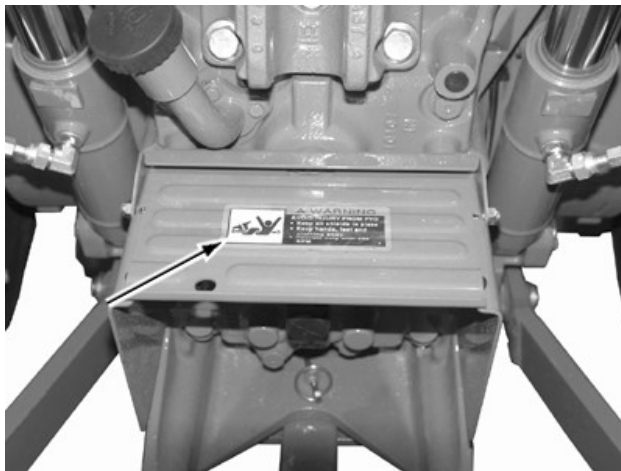

LV15875—UN—18JUL12

Rear PTO Shield

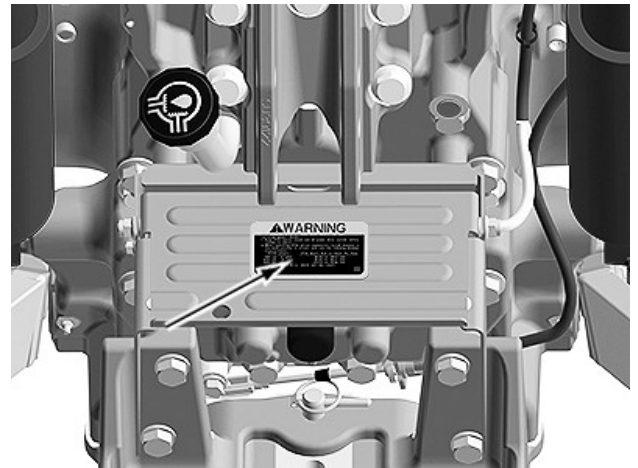

RXA0184729—UN—11AUG21

Rear PTO Shield



APY78936—UN—31JAN23

Front PTO Shield (1000 RPM, If Equipped)

WARNING

TO AVOID BODILY INJURY:

1. Keep PTO master shield and all power drive system safety shields in place.
2. When operating PTO driven implements, install drawbar in the down position if offset, and use the following drawbar instructions:

PTO shaft	PTO Shaft End to Hitch Pin Hole
540 rpm - 6 spline	14.00 in (356 mm)
1000 rpm - 21 spline	16.00 in (407 mm)
*1000 rpm - 20 spline	20.00 in (508 mm)

WARNING

PTO shaft

PTO Shaft End to Hitch Pin Hole

*1.75 in (44.5 mm) dia. shaft

GS25068,0001929-19-11AUG21

speeds that may exceed the maximum allowable transport speed for towed implements. If implement manufacturer does not specify maximum transport speed, observe these transport speed limits:

—Implements without brakes: 32 km/h (20 mph)

—Implements with brakes: 40 km/h (25 mph)

Do not exceed the implement's maximum transport speed.

MP60050,00009C4-19-02FEB21

Tow Implement Properly



LV15900—19—25JUL12

Front End Loader



RXA0068062—19—29JUN05



LV15826—UN—22JUN12

Left-Hand Door Post

WARNING

Avoid serious injury or death resulting from loss of control during transport or braking of a towed implement.

This tractor is capable of operating at transport



LV14487—UN—28JUL11

Right-Hand Post

WARNING

AVOID INJURY OR DEATH CAUSED BY FALLING LOADS

When using loader **ALWAYS** put SCV selector knobs in loader position.

If you do not, loader will continue to move after controls are released.

See operators manual for use of other knob positions.

MP60050,00009C5-19-02FEB21

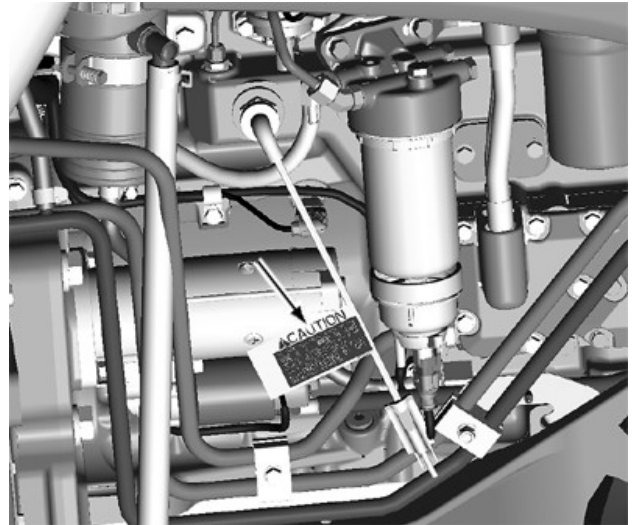

LV21963—UN—30MAY14

Right Side of Engine

CAUTION

TO AVOID ELECTRICAL SHOCK OR FIRE USE A 3-WIRE 14 AWG HEAVY-DUTY ELECTRICAL CORD WITH 15 AMP RATING SUITABLE FOR OUTDOOR USE. ALWAYS PLUG ELECTRICAL CORD INTO 120 VOLT OUTLET PROTECTED BY GFI (GROUND FAULT INTERRUPTER.)

GS25068,0003F93-19-14FEB18

Engine Coolant Heater



RXA0148588—19—09JUL15

AutoTrac Detected

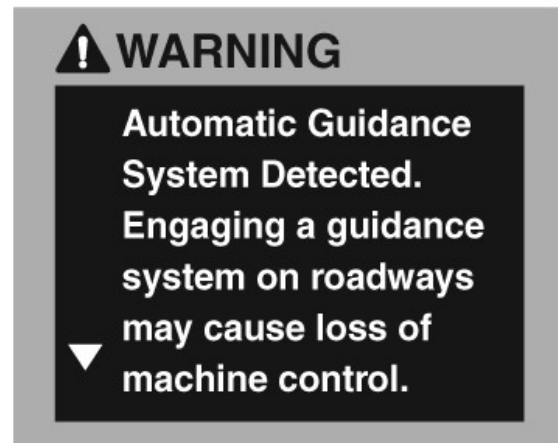

RXA0178550—UN—26JUN20



RXA0170764—UN—02OCT19



RXA0180138—UN—26JAN21

Left-Hand Side Information Screen

WARNING

Automatic Guidance System Detected.

Engaging a guidance system on roadways may cause loss of machine control.

To avoid death or serious injury, disable the guidance system before entering roadways.

NOTE: This message occurs during start-up on machines with an automatic guidance system installed when a valid track is selected.

MP60050,0000AFC-19-19MAY21

Controls and Instruments

Front Console Controls

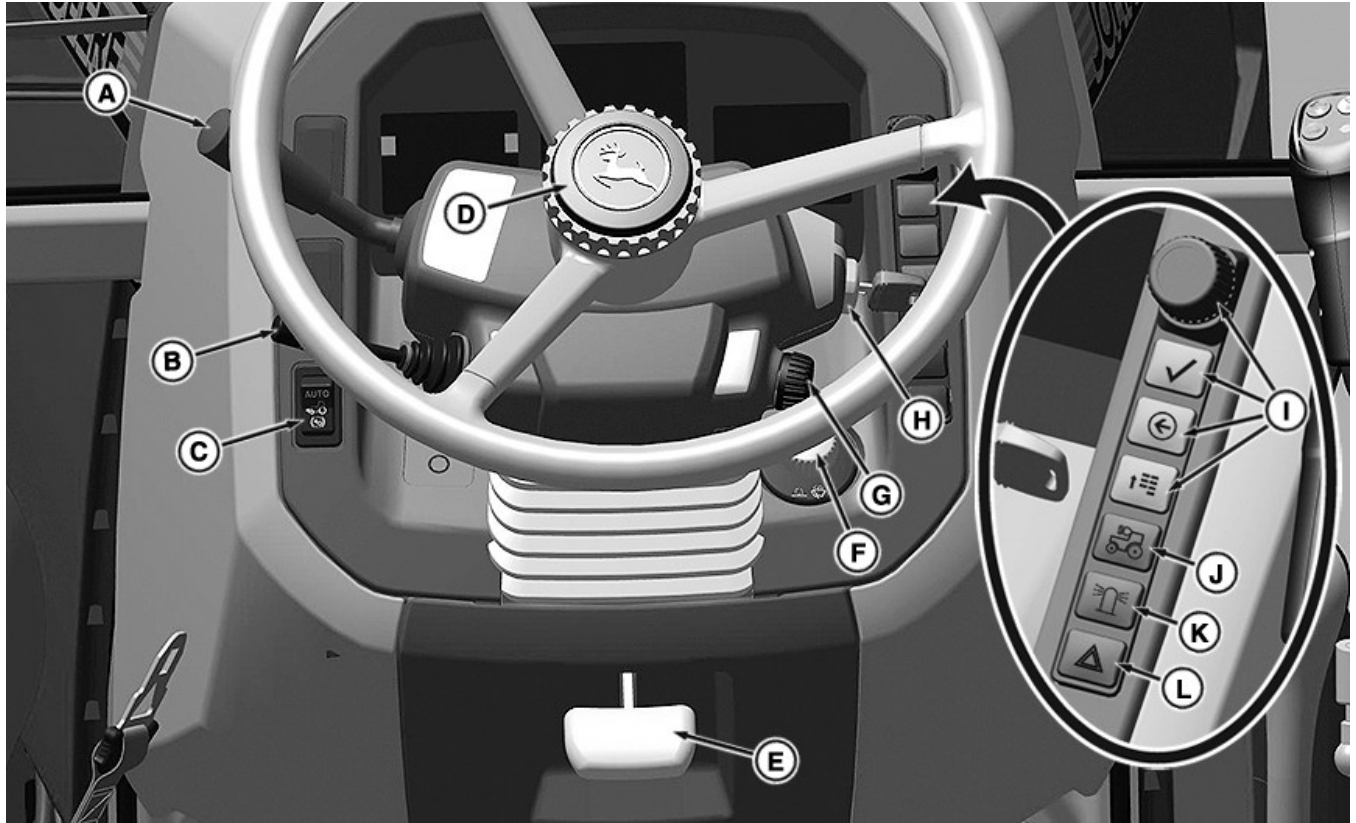

RXA0181719—UN—13APR21

- A—Left-Hand Reverser Lever
- B—Turn Signal, Horn, and High/Low Beam Switch
- C—MFWD Switch
- D—Steering Wheel Telescoping Knob
- E—Steering Wheel Tilt Lever
- F—Front Wiper Switch

- G—Light Switch
- H—Key Switch
- I—Display Navigation Module
- J—Loader Headlights Switch
- K—Beacon Light Switch
- L—Warning Lights Switch

MP60050,0000AEF-19-17MAY21

Foot-Operated Controls

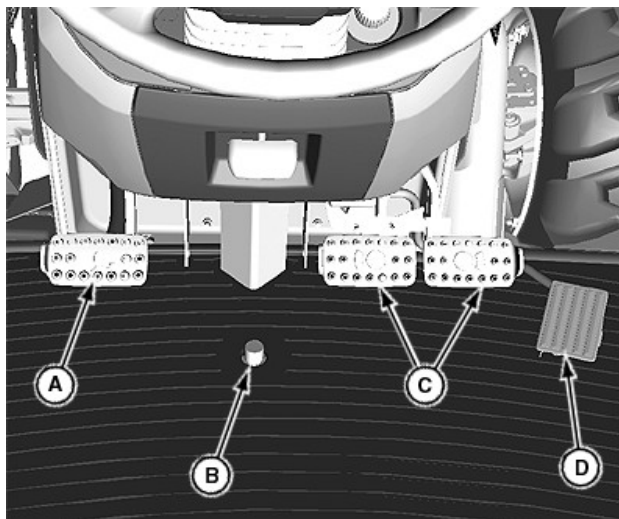

LV21794—UN—09MAY14

- A—Clutch Pedal
- B—Differential Lock Switch
- C—Brake Pedals
- D—Foot Speed Control Pedal

MP60050,0000AF0-19-17MAY21

Console Controls

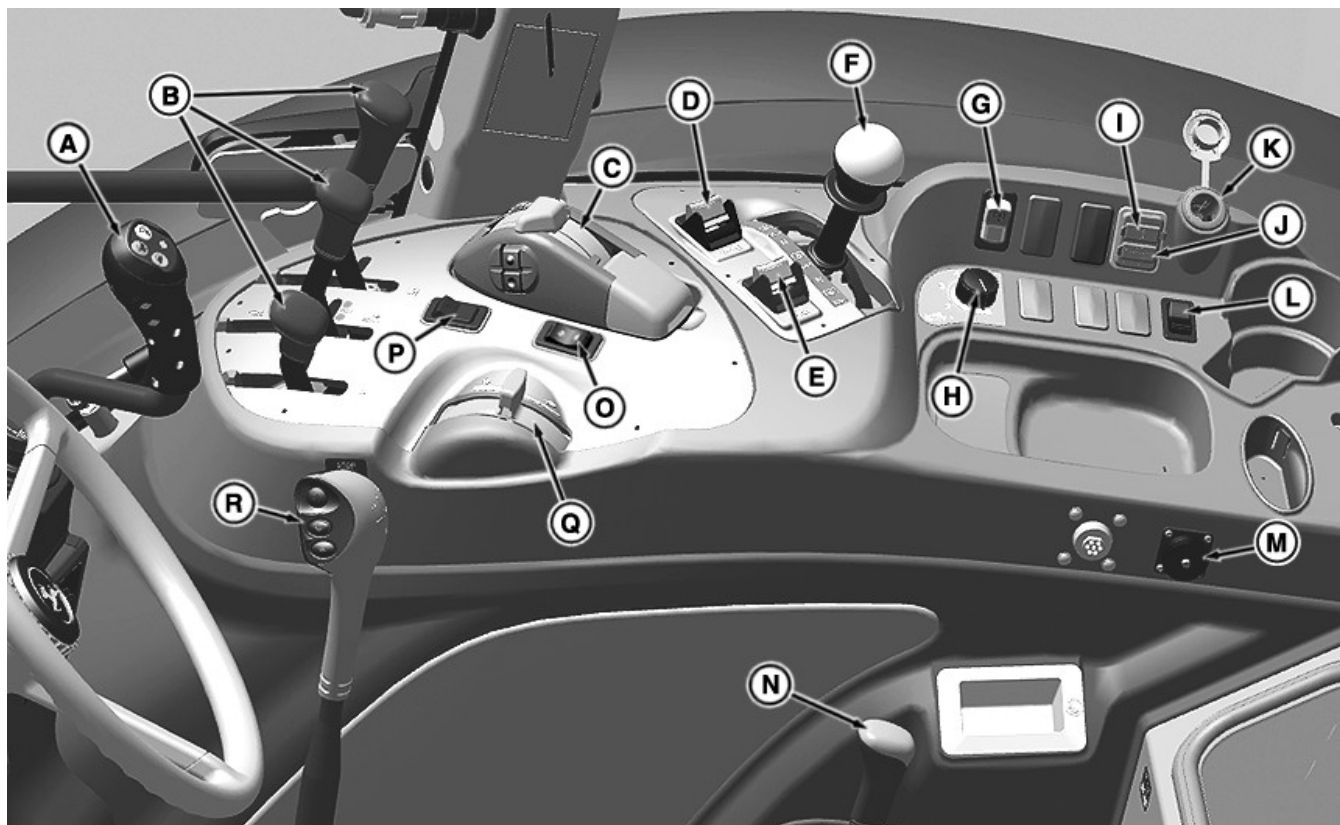

RXA0182559—UN—10MAY21

- A—Mid-Mount SCV Joystick
- B—Rear SCV Lever (3)
- C—Rear Hitch Control
- D—Front PTO Switch
- E—Rear PTO Switch
- F—PTO Speed Shift Lever
- G—Remote PTO Enable Switch
- H—Rear Hitch Draft Control Knob
- I—Auxiliary Output Jack

- J—USB Connector
- K—Power Outlet
- L—Rear Wiper Switch
- M—Convenience Outlet
- N—Creeper Lever
- O—Speed Shift Switch
- P—AutoTrac Resume Switch
- Q—Hand Speed Control
- R—Range Shift Lever

MP60050,0000AEE-19-17MAY21

Transmission Controls

Gear Shift Controls

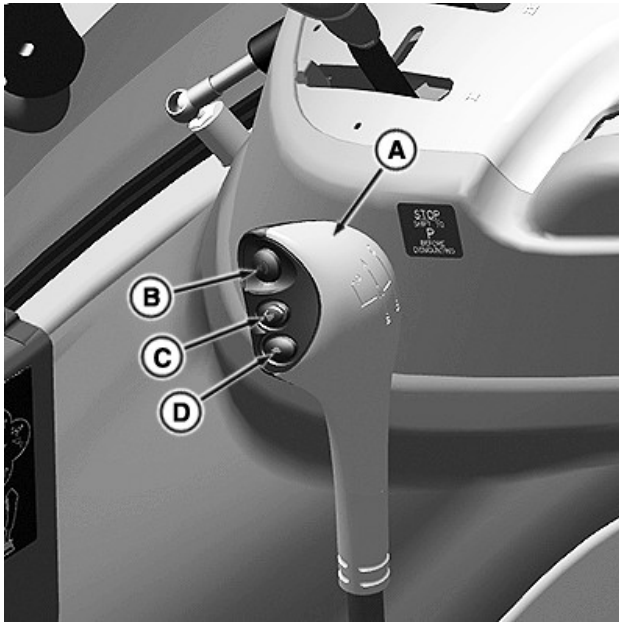

RXA0182562—UN—30APR21

Declutch with Hi/Lo

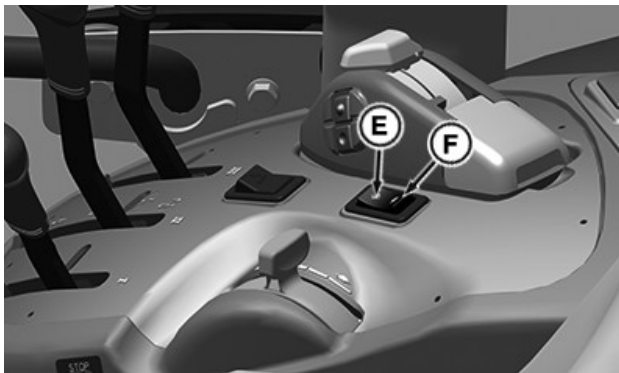

RXA0181710—UN—11MAR21

Right-Hand Console Speed Shift Switch

- A—Gear Shift Lever
- B—Declutch Button
- C—Speed Shift Up
- D—Speed Shift Down
- E—Speed Shift Up
- F—Speed Shift Down

Left-Hand Reverser



RXA0181711—UN—11MAR21

A—Left-Hand Reverser Lever

Creep Shift Lever

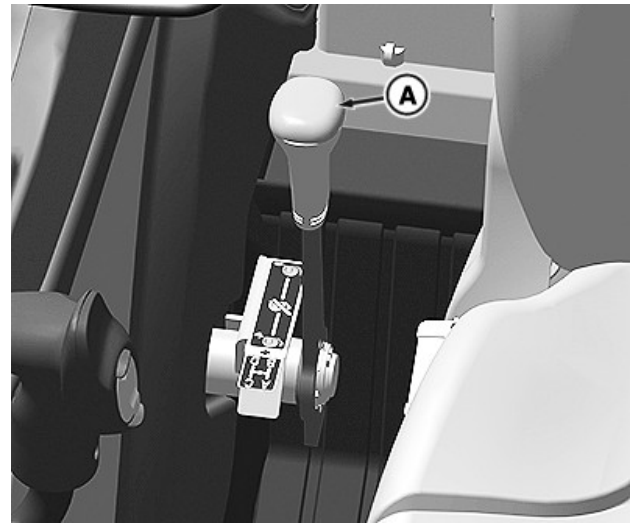

RXA0157551—UN—16FEB17

A—Creep Shift Lever

D3K5H22,0000574-19-29APR21

Mid-Mount SCV Joystick Controls

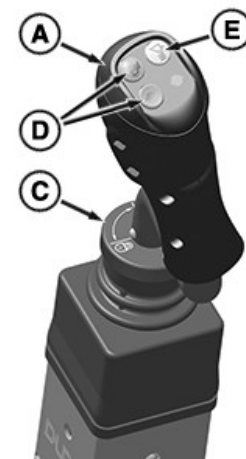

RXA0161910—UN—31JAN18

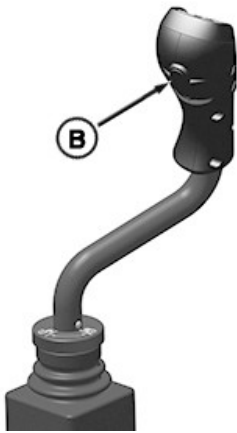

RXA0161911—UN—31JAN18

- A—Mid-Mount SCV Joystick
- B—Third-Function Switch
- C—Loader Lock
- D—Gearshift Buttons
- E—Loader Suspension Button

D3K5H22.00005EF-19-17MAY21

Rear Hitch Controls

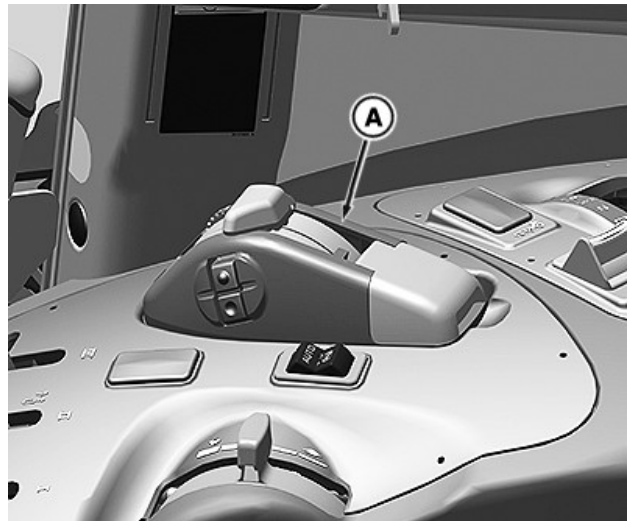

RXA0157553—UN—16FEB17



RXA0181708—UN—10MAR21

- A—Electrohydraulic Rear Hitch Controls
- B—Rear Hitch Fender Switch

D3K5H22.0000568-19-10MAR21

Rear SCV Controls



LV14585—UN—10AUG11

- A—SCV I Lever
- B—SCV II Lever
- C—SCV III Lever

MP60050.0000984-19-15FEB17

Rear PTO Controls

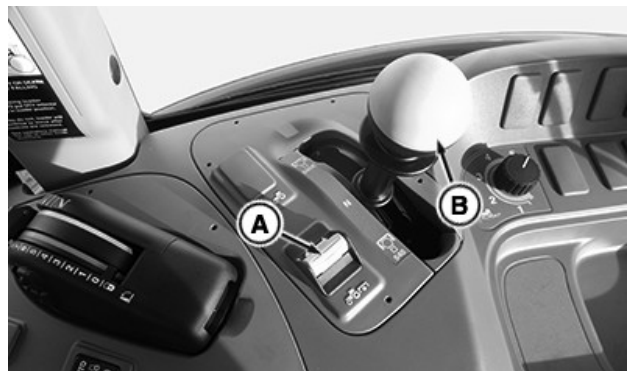

RXA0157557—UN—21FEB17



RXA0154427—UN—11NOV16

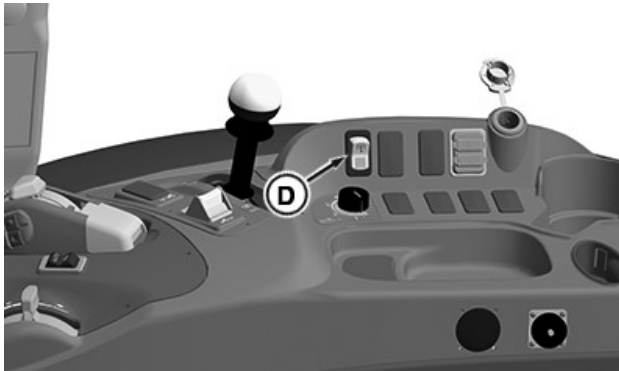

RXA0158332—UN—02MAY17

- A—Rear PTO Switch
- B—2-Speed Rear PTO Shift Lever
- C—Rear PTO Fender Switch
- D—Remote PTO Enable Switch

D3K5H22.00005F3-19-10MAY21

Heat and Air Conditioning Controls



LV14499—UN—28JUL11

- A—Air Conditioning/Defrost Switch
- B—Air Conditioning Control Knob
- C—Heat Control Knob
- D—Fan Speed Knob

DP51502.0002A00-19-21FEB17

Front PTO Controls

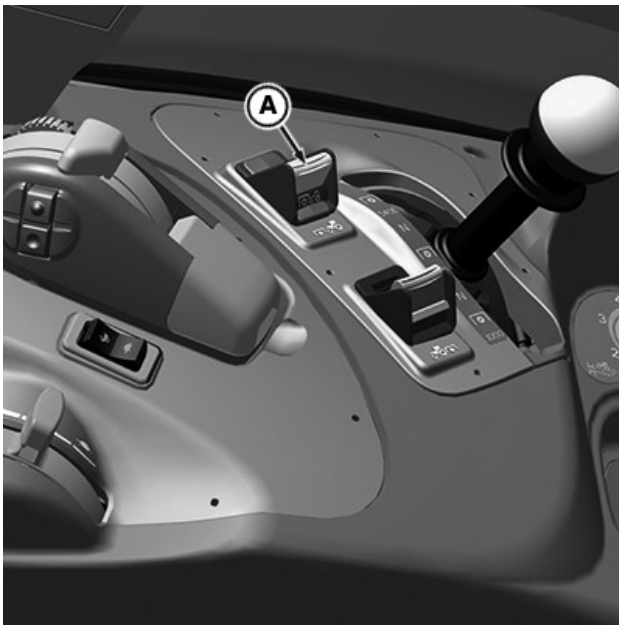

RXA0181001—UN—25FEB21

- A—Front PTO Switch

D3K5H22.0000546-19-24FEB21

Engine Operation

Required Machine Stop Warning

Machine Stop Mandate Occurs

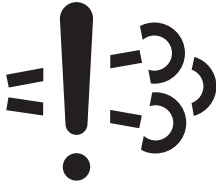

RG22491—UN—21AUG13

IMPORTANT: In some situations, machine engine power may be reduced as described. On notification, immediately place the machine in a safe state and or move it to a safe location. A mandated machine stop can only be removed by a service technician.

Engine Emissions System Malfunction Indicator illuminates when an emission-related fault occurs.



RG22492—UN—21AUG13

Warning Indicator illuminates when a condition exists which requires operator action.



RG22493—UN—21AUG13

Engine Stop Indicator illuminates when a condition exists which requires immediate operator action and service.

Emission System Fault Has Occurred

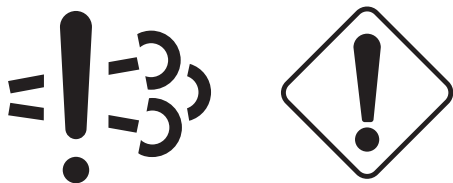

RG26361—UN—04SEP14

30 minutes remaining, Engine Emissions System Malfunction and Warning Indicators are illuminated and alarm sounds to warn operator of emissions-related fault. "Less than 30 minutes to Power Restriction" displayed on machines with display.

- Engine power is normal.
- Machine operation is normal.
- Place machine in a safe state.
- Contact service provider.



RG26972—UN—26MAR15

20 minutes remaining, Engine Emissions System Malfunction and Engine Stop Indicators are illuminated and alarm sounds to warn operator of emissions-related fault. "Less than 20 minutes to Power Restriction" displayed on machines with displays.

- Engine power and torque are reduced.
- Key Off - Key On will temporarily provide full power.
- Place machine in a safe state.
- Contact service provider.



RG26972—UN—26MAR15

2 minutes or less remaining, Engine Emissions System Malfunction and Engine Stop Indicators are illuminated and alarm sounds to warn operator of emissions-related fault which has not been corrected. "Power Restriction" displayed on machines with displays.

- Engine power is idle only.
- Place machine in a safe state.
- Contact service provider.

DX,MACHSTOPWARN,AG-19-02OCT15

Engine Menu

NOTE: For additional navigation information, see Basic Menu Navigation in the Displays, Software, and Electronics Operation section.



Engine Menu

RXA0152958—UN—21JUL16

1. Locate the engine menu.



RXA0152960—UN—21JUL16
Auto Filter Cleaning Selection

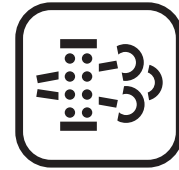

RXA0152961—UN—21JUL16
Filter Cleaning Selection

2. Select and change the desired settings as needed. See the relevant topic in this section for additional details on settings.

Selection	Range	Engine Response
Auto Filter Cleaning	Automatic cleaning or cleaning disabled.	Automatic cleaning allows exhaust filter cleaning to occur during operation when certain conditions are met. Cleaning disabled prevents automatic cleaning. When the engine is cycled off, it defaults back to automatic.
Filter Cleaning	Parked filter cleaning.	If the symbol is not grayed out, a parked filter cleaning can be performed.

D3K5H22,000055F-19-05MAR21

Engine Fuel System and Power Rating

IMPORTANT: Modification or alteration of the injection system or emission control devices terminates warranty to purchaser.

Do not attempt to service injection system. Special training and special tools are required. See your John Deere dealer.

Engine Certification/Power Rating: kW (hp) rating on the emission certification label specifies gross engine kW (hp), which is flywheel power without fan.

DP51502,0002A10-19-31JAN17

Check Engine Indicators and Gauges

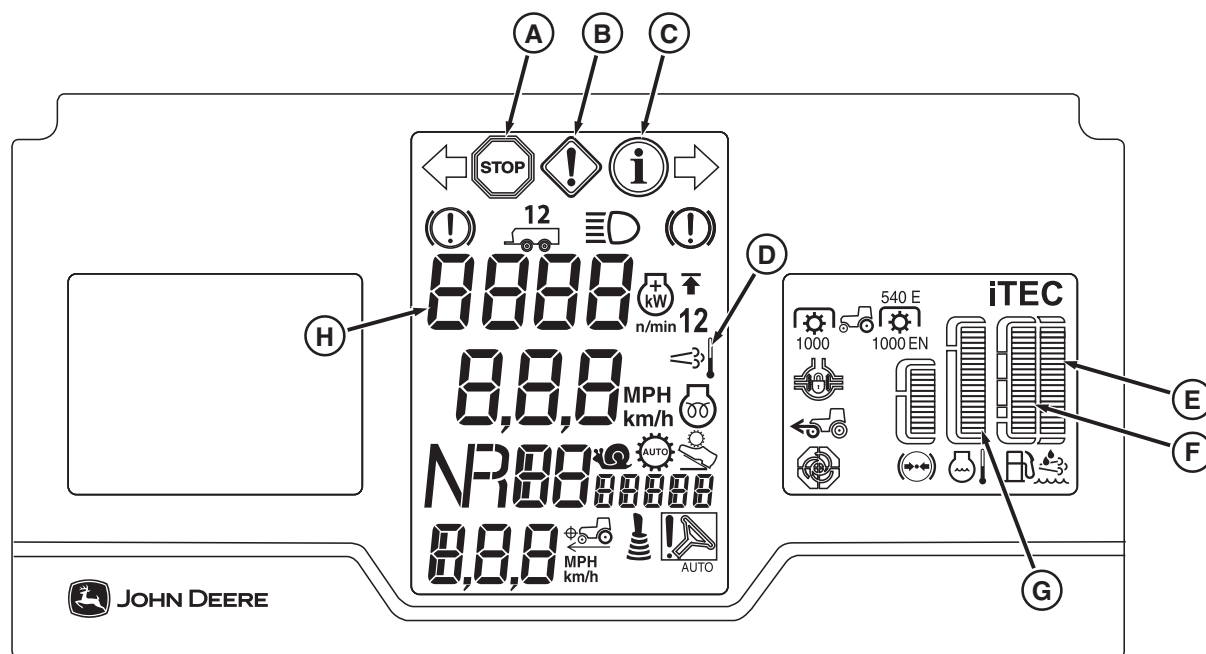

- A—STOP Indicator
- B—Warning Indicator
- C—Information Indicator
- D—Exhaust Temperature Indicator

STOP Indicator (A): Flashes and an audible alarm sounds continuously if a serious malfunction occurs. Diagnostic trouble codes are present, requiring a machine shutdown. Immediately stop, reduce engine speed, then SHUT OFF engine or machine damage occurs. If necessary, have your John Deere dealer diagnose problems.

Warning Indicator (B): Flashes and an audible alarm sounds five times if a malfunction occurs. Diagnostic trouble codes are present, but they do not require an immediate machine shutdown. Access information display to determine severity of DTCs. If necessary, have your John Deere dealer diagnose the problem.

Information Indicator (C): Illuminates continuously to indicate a possible problem. Diagnostic trouble codes may be present. Access information display to determine if diagnostic trouble codes are present. If necessary, have your John Deere dealer diagnose the problem.

Exhaust Temperature Indicator (D): Illuminates if high temperatures exist inside the exhaust filter, which allow active filter cleaning to occur.

RXA0180995—UN—05FEB21

- E—Diesel Exhaust Fluid (DEF) Gauge
- F—Fuel Level Gauge
- G—Engine Coolant Temperature Gauge
- H—Tachometer

Diesel Exhaust Fluid (DEF) Gauge (E): Indicates the volume of DEF in the tank. As volume is reduced, bars disappear from the display. Avoid running out of DEF to prevent damage to engine components.

Fuel Level Gauge (F): Indicates the volume of fuel left in the tank. As volume is reduced, bars disappear from the display. Avoid running out of fuel to prevent damage to engine components.

Engine Coolant Temperature Gauge (G): Indicates the engine coolant temperature. If indicator bars reach the red zone on the display, stop engine. Clean debris from grilles, radiator, and coolers. Allow the engine to cool completely, then check coolant level and fan belt tension.

Tachometer (H): Engine revolutions per minute (rpm) are represented in hundreds.

D3K5H22,0000562-19-09MAR21

Operate Key Switch



LV14537—UN—02AUG11

- A—ACCESSORY Position
- B—STOP Position
- C—RUN Position
- D—START Position

NOTE: If temperature is below 5°C (41°F), see Cold Weather Start procedure in this section.

ACCESSORY (A): Push in and turn key to ACCESSORY position to power electrical functions.

STOP (B): Turn key to STOP position to stop engine and turn off electrical functions.

RUN (C): Turn the key switch to RUN position. Check gauges and indicator lights before starting.

START (D): Turn key to START position to start engine. Key returns to run position when released.

GS25068,000539B-19-18SEP18

Start Engine

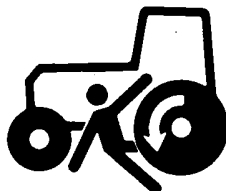
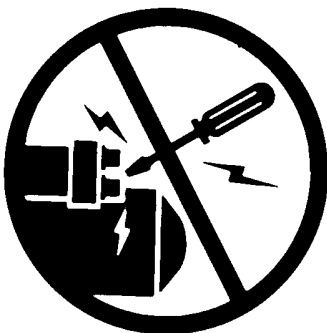

TS177—UN—11JAN89

CAUTION: Do not start engine by shorting across starter terminals. Machine starts in gear when the normal circuitry is bypassed. Start engine **ONLY** from the operator's seat.

Avoid possibility of personal injury or death. Engine starting with shift lever in gear indicates malfunction of the starting circuit. Repair immediately. See your John Deere dealer.

Avoid possibility of serious injury or death. Be sure that machine and attached equipment are clear of people and other objects.

IMPORTANT: Do not use starting fluid. Damage to engine can occur.

1. Check fuel, DEF, engine oil, and coolant levels before starting the engine. Fill as required.
2. Place left-hand reverser in neutral position.
3. Place hand speed control in idle position.
4. Disengage PTO.
5. Place SCV levers in neutral position.
6. Lower hitch completely if an implement is attached.
7. Turn the key switch to run position. Do not start engine.
8. Wait until light check sequence is complete.
9. Check for any indicator lights or diagnostic trouble codes that impair machine performance. If necessary, have your John Deere dealer diagnose the problem.
10. Depress clutch and brake pedals.
11. Sound horn.
12. Turn key switch to engage the starter. Release key when engine starts.

IMPORTANT: Avoid starter damage. Do not operate the starter for more than 30 seconds. Wait at least 2 minutes before trying again.

If Engine Fails to Start:

- Place hand speed control at 1/4 to 1/3 of full throttle and attempt to start machine again.
- In cold weather (at or below 5°C [41°F]), refer to Cold-Weather Start procedure in this section.
- Check for diagnostic trouble codes or electrical problems.
- If engine fails to start after three attempts, see your John Deere dealer.

NOTE: In cold weather, engine speed is limited to 1440 rpm until transmission/hydraulic oil temperature is above -18°C (0°F).

MP60050,0000AF1-19-17MAY21

Cold Weather Start

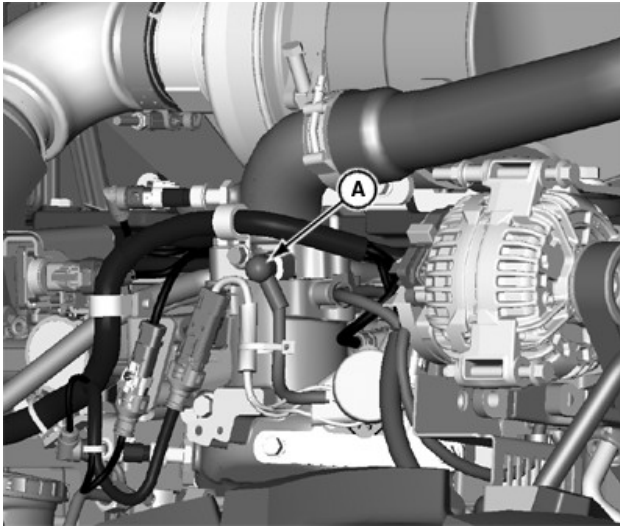

LV22525—UN—24JUL14

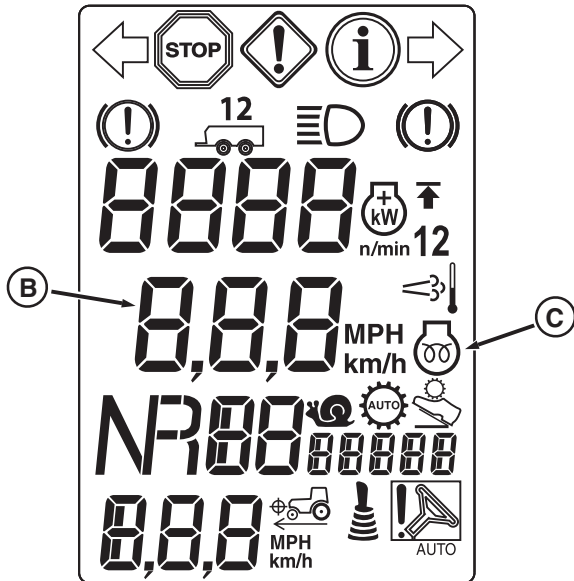

RXA0180994—UN—20JAN21

Cold Start Indicators

- A—Air Intake Heater
- B—Machine Ground Speed
- C—Cold Start Indicator Icon

IMPORTANT: Do not use starting fluid.

1. Turn key switch to RUN position, but do not start engine.
2. Observe display for the cold start indicator icon (C) to appear.
3. A cold start countdown begins, utilizing the ground speed icon (B) to indicate the air intake heater (A) is heating up.

4. When the cold start countdown reaches zero, icon turns off.
5. Start engine and allow to warm up. (See Run Engine in this section for procedure.)

D3K5H22,000059F-19-31MAR21

Run Engine

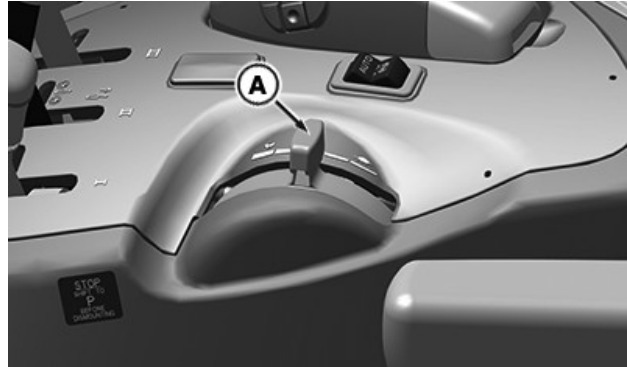

RXA0157945—UN—24FEB17

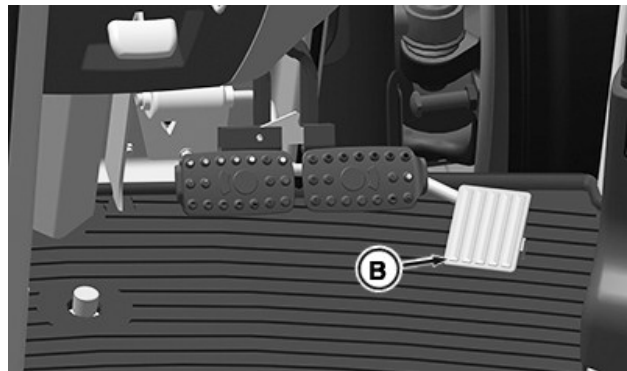

RXA0157946—UN—24FEB17

- A—Hand Speed Control
- B—Foot Speed Control

1. Start engine.
2. Set hand speed control (A) to 1200 rpm.
3. Allow engine to run at 1200 rpm without load for 1—2 minutes if temperature is above 0°C (32°F). If temperature is below 0°C (32°F), run without load for 2—4 minutes. If temperature is extremely cold, it takes longer to get engine warm enough to operate.
4. Once engine is warm, push hand speed control (A) forward to increase speed.
5. Depress foot speed control (B) to increase engine speed temporarily above the hand speed control setting.

MP60050,0000AF2-19-17MAY21

Engine Speeds and Operational Procedures

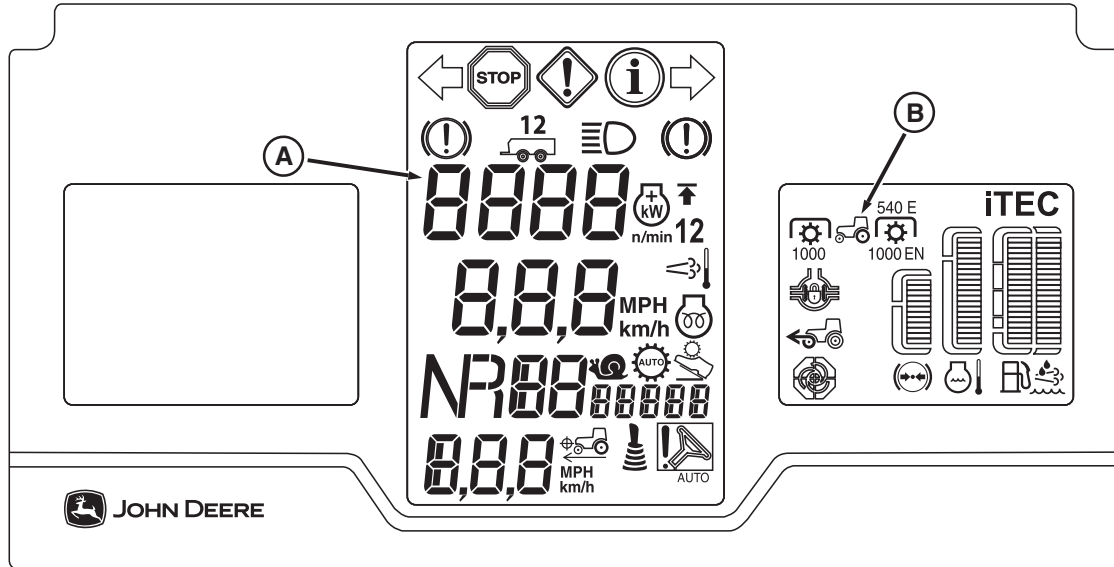

RXA0180996—UN—05FEB21

A—Tachometer

Warm Up Engine

Do not place machine under full load until it is properly warmed up.

1. Run engine with tachometer (A) reading 1200 rpm for several minutes.

NOTE: In cold weather, engine speed is limited to 1440 rpm until transmission/hydraulic oil temperature is above -18°C (0°F).

If hydraulic functions operate slowly, warm the transmission/hydraulic system oil. See Warm Transmission/Hydraulic System Oil in Hydraulics Operation section.

2. Run engine at approximately 1900 rpm under light load until engine reaches normal operating condition.

Avoid Idling Engine

Prolonged idling causes engine coolant temperature to fall below normal range. Prolonged idling causes crankcase oil dilution, due to incomplete fuel combustion, and permits formation of gummy deposits on valves, pistons, and piston rings. It promotes rapid accumulation of engine sludge and unburned fuel in the exhaust system.

B—PTO Status Icons

If machine must be left with the engine running for more than 3 or 4 minutes, minimum engine speed must be 1200 rpm.

Engine Work Speeds

- Engine nominal full load speed is 1600—2200 rpm.
- Do not operate engine constantly below 1500 rpm during heavy draft usage or when machine is under full PTO load.

PTO Speeds

- PTO speed and PTO status (B) are indicated when PTO is engaged.
- PTO mode value is displayed according to PTO speed selected (540E, 540, or 1000).
- Recommended engine speed is 2100 rpm for 540 and 1000 PTO.
- Recommended engine speed is 1645 rpm for 540E PTO.

Restart Stalled Engine

If engine stops running due to overload, immediately restart engine. A running engine causes oil and coolant to circulate, which prevents abnormal heat buildup. If engine stalls but does not stop running due to overload,

run at low idle for 1 or 2 minutes in order to dissipate heat buildup.

D3K5H22,0000565-19-09MAR21

6. If engine does not start, contact your John Deere dealer.

GS25068,00053A0-19-18SEP18

Stop Engine



RXA0157945—UN—24FEB17

A—Hand Speed Control

IMPORTANT: Idle an engine that has been operating at working load at least 1 or 2 minutes at 1000—1200 rpm to cool. If an exhaust filter cleaning has recently been completed, increase engine idle time to 4 minutes.

1. Place left-hand reverser in neutral position.
2. Place hand speed control (A) in idle position.
3. Disengage PTO.
4. Lower any equipment to the ground.
5. Place SCV levers in neutral position.
6. Lower hitch completely if an implement is attached.
7. Turn key to STOP and remove.

MP60050,0000AF3-19-17MAY21

Restart Engine That Has Run Out of Fuel

IMPORTANT: Do not attempt to start for longer than 20 seconds at a time and allowing 20-30 seconds between to avoid starter damage.

1. Fill fuel tank.
2. Bleed the fuel system to remove excess air. (See Bleed Fuel System in Air, Fuel, Coolant, and Exhaust Maintenance section.)
3. Attempt to start engine two or three times.
4. If engine does not start, bleed the fuel system again.
5. Attempt to start engine two or three times.

Engine Block Coolant Heater



LV18039—UN—11JUN13

Right Side of Engine

A—Engine Block Coolant Heater

CAUTION: To avoid electrical shock or fire, use a heavy-duty electrical cord. Ensure that it is a 3-wire, 14 AWG (14 gauge), that is no longer than 7.6 m (25 ft), 15 amperes rated, and is suitable for outdoor use. Before connecting heater to a power source, be sure that element is immersed in coolant. NEVER energize the heater in air. Doing so can cause the element sheath to burst, resulting in personal injury.

1. Locate engine block coolant heater (A) on the engine.
2. Connect heater plug to a 120-volt outlet protected by ground fault interrupter.

D3K5H22,0000567-19-09MAR21

Air Intake, Fuel, Coolant, and Exhaust Operation

Aftertreatment Indicators Overview



Diesel Exhaust Fluid Indicator

RG22487—UN—21AUG13

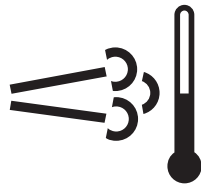

Engine Emissions Temperature Indicator

RG22488—UN—21AUG13

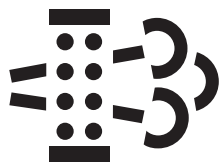

Exhaust Filter Indicator

RG22489—UN—21AUG13

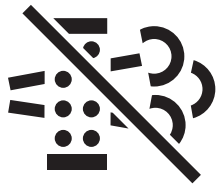

Auto Cleaning Disabled Indicator

RG22490—UN—21AUG13

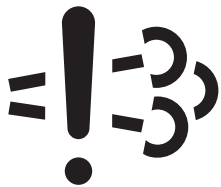

Engine Emissions System Malfunction Indicator

RG22491—UN—21AUG13



Warning Indicator

RG22492—UN—21AUG13



Engine Stop Indicator

RG22493—UN—21AUG13

IMPORTANT: The operator will be informed by the operator warning system when the emission control system does not function correctly and/ or an engine malfunction is detected by the engine control unit. Ignoring the operator warning signals will lead to an emission related derate, resulting in an effective disablement of non-road mobile machinery operation.

It is essential to take prompt action to rectify any incorrect operation, use or maintenance of the emissions control system in accordance with the rectification measures indicated by the warnings referenced below.

The Diesel Exhaust Fluid (DEF) indicator illuminates when the DEF is low. Fill DEF tank.

When the DEF indicator is combined with the warning indicator or engine stop indicator engine performance is reduced by the Engine Control Unit (ECU) because the DEF is below a measurable level. Fill DEF tank.

When engine emissions temperature indicator illuminates exhaust gas temperature is high, elevated idle is active, or exhaust filter cleaning is in process. The machine can be operated as normal unless the operator determines the machine is not in a safe location for high exhaust temperatures and disables auto cleaning.

When engine emissions temperature indicator is combined with the warning indicator or engine stop indicator engine performance is reduced by the ECU because the exhaust gas temperature is higher than expected. Follow Diagnostic Trouble Code (DTC) procedure or see your authorized servicing dealer.

When the exhaust filter indicator illuminates the exhaust filter cleaning is in process, aftertreatment system has a fault, or the exhaust filter is in need of cleaning and the operator has disabled auto exhaust filter cleaning. If conditions are safe, the operator should enable the auto exhaust filter clean setting or perform manual service regeneration or follow DTC procedure.

When the exhaust filter indicator is combined with the warning indicator engine performance is reduced by the ECU because there is an aftertreatment system fault or the soot level of the exhaust filter is moderately high. If conditions are safe, the operator should enable the auto exhaust filter clean function. If conditions are not safe, the operator should move the machine to a safe location and engage the auto exhaust filter cleaning mode.

Perform manual service regeneration or follow DTC procedure.

When the exhaust filter indicator is combined with the engine stop indicator engine performance is further reduced by the ECU because there is an aftertreatment system fault or the soot level of the exhaust filter is extremely high. If this combination is present, see your authorized servicing dealer.

The auto cleaning disabled indicator illuminates when the operator has engaged the request to disable the auto exhaust filter cleaning function. This icon remains illuminated until the operator re-engages automatic exhaust filter cleaning from the diagnostic gauge. Disabling auto mode is not recommended for any situation unless it is safety-related or if the fuel tank

lacks the required fuel to complete the cleaning process.

The engine emissions system malfunction indicator illuminates when engine emissions are outside of normal operating range or engine emissions system fault. Follow DTC procedure or see your authorized servicing dealer.

When the engine emissions system malfunction indicator is combined with the warning indicator engine performance is reduced by the ECU because the engine emissions are outside of normal operating range or engine emissions system fault. Follow DTC procedure or see your authorized servicing dealer.

DX,AFTRTREAT,INDCATRS-19-12FEB18

Selective Catalytic Reduction (SCR) System Overview

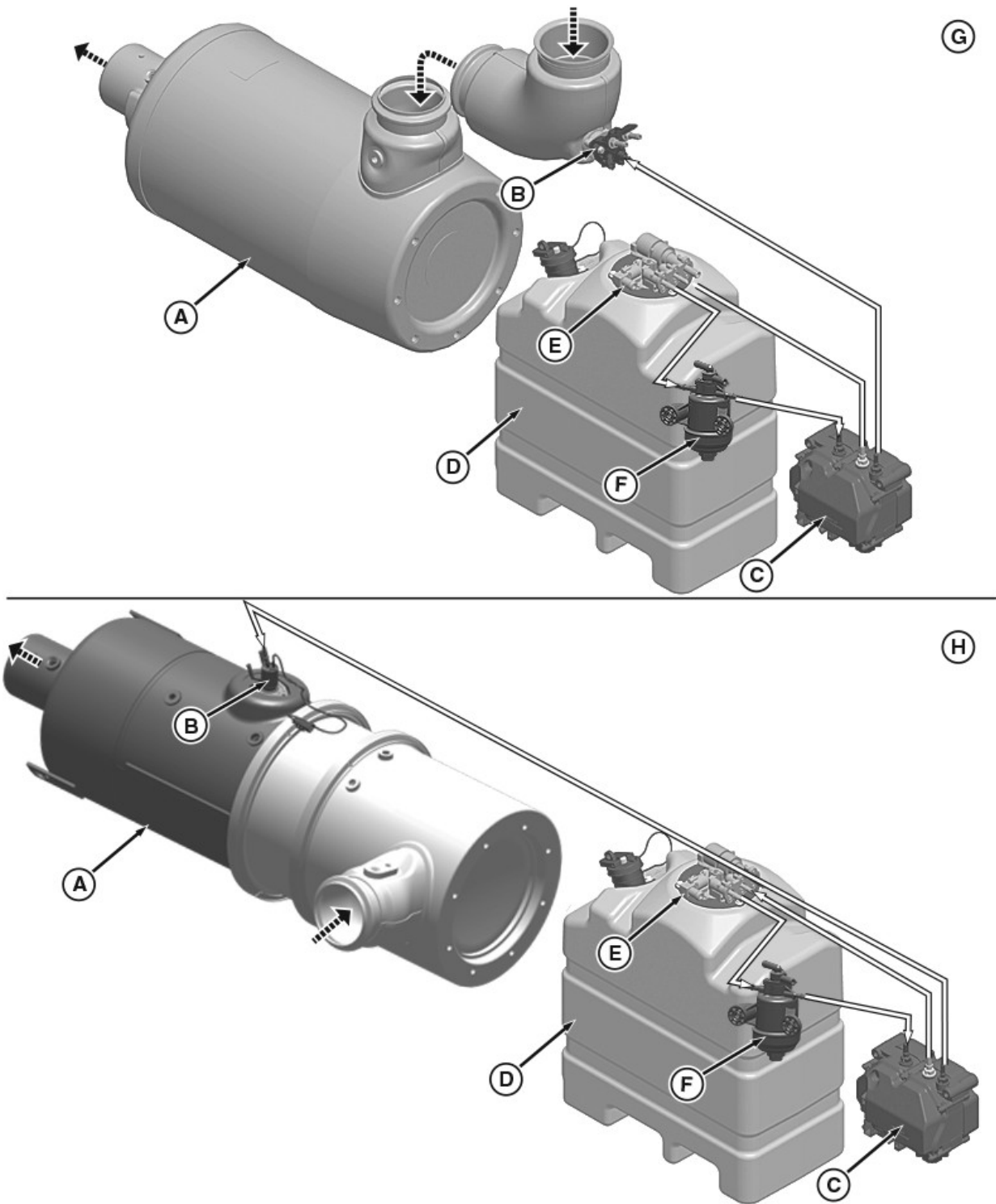

RG22427A—UN—07JAN20

SCR System

A—SCR Catalyst
B—DEF Dosing Injector
C—DEF Dosing Unit
D—DEF Tank

E—DEF Tank Header Assembly
F—Inline DEF Filter (If Equipped)
G—Modular Canning Configuration
H—Inline Canning Configuration

IMPORTANT: Do not remove battery leads for at least 4 minutes after engine stops. The SCR system automatically purges itself of Diesel Exhaust Fluid (DEF) immediately after the engine is stopped. If adequate time is not allowed for lines to be purged, residual DEF can freeze and possibly damage components of the SCR system during cold-weather exposure.

In order to comply with national and local emission requirements, this engine series contains a Selective Catalytic Reduction (SCR) system. The main components of the SCR system include the SCR catalyst (A), DEF dosing injector (B), DEF dosing unit (C), DEF tank (D), and DEF tank header assembly (E). The SCR system is effective at reducing the nitrogen oxides (NOx) emissions. NOx is a major component of smog and acid rain.

During combustion, NOx molecules are formed in the exhaust. DEF is injected into the exhaust stream before the SCR catalyst. Through a chemical reaction in the SCR, NOx is converted into nitrogen and water.

Water vapor is a normal by-product of combustion. During cold-weather operation at low exhaust temperatures, this water vapor can condense and resemble white smoke from the exhaust. This will dissipate as operating temperature increases and the water is further vaporized. This situation is considered normal.

A DEF solution begins to crystallize and freeze at -11 °C (12 °F). With climate temperatures that can range much colder than this, DEF is expected to freeze in the DEF tank. For this reason, the DEF tank contains a heating element that provides rapid thawing of DEF upon start-up. The heating element cycles to maintain fluidity during operation as needed. DEF is not dosed upon initial start-up, therefore it is not necessary to have liquid DEF at cold start-up.

If DEF quality deteriorates and it is no longer within specifications, the engine can derate. DEF should be crystal clear with a light ammonia smell. If DEF appears cloudy, has a colored tint, or has a profound ammonia smell, it is likely not within specification.

DX,SCR,OVERVIEW-19-30MAR20

US EPA Qualified Emergency Use — SCR Derate Override Option

NOTE: This is a US EPA only option.

IMPORTANT: Operating the engine without emissions related derates could damage the aftertreatment system.

Description: US EPA Qualified Emergency Use – SCR Derate Override Option

Under the US EPA's regulations the Qualified Emergency SCR Derate Override Option (Emergency SCR Derate Override) is considered an Auxiliary Emission Control Device (AECD), which is only permitted during qualified emergency situations. To ensure compliance with US EPA regulations governing this type of AECD it is important that operators read the following information and comply with the requirements.

Emergency SCR Derate Override enables a Selective Catalyst Reduction (SCR) equipped application to operate without emissions-related derates for a specified period of time during qualified emergency situations. A qualified emergency situation is one in which the condition of an engine's emission controls poses a significant direct or indirect risk to human life. An example of a direct risk is an emission control condition that inhibits the performance of an engine being used to rescue a person from a life-threatening situation. An example of an indirect risk is an emission control condition that inhibits the performance of an engine being used to provide electrical power to a data center that routes "911" emergency response telecommunications.

Emergency SCR Derate Override Activation / Reporting

The operator can activate the Emergency SCR Derate Override through the operator interface. Once activated, the engine can operate free of emissions-related derates for 120 hours. If the derate condition is corrected during the 120 hours, the Emergency SCR Derate Override can be paused in order to preserve the remainder of time for future use. The option expires along with any remaining time 240 hours after the Emergency SCR Derate Override is activated.

When the Emergency SCR Derate Override has expired, the engine informational Diagnostic Trouble Code (DTC) is displayed to the operator upon every engine start and every hour until acknowledged by the operator. To clear the DTC and reset the Emergency SCR Derate Override timer for future use, the operator (or other person responsible for the engine/equipment) must submit a report to the John Deere Dealer Technical Assistance Center, which must include the following:

- Contact name, mail and email addresses, and telephone number for responsible company or entity
- Description of the emergency situation, the location of the engine during the emergency, and the contact information for an official who can verify the emergency situation (such as a county sheriff, fire marshal, or hospital administrator)
- Reason for the Emergency SCR Derate Override activation during the emergency situation, such as the lack of diesel exhaust fluid, or the failure of an

emission-related sensor when the engine was needed to respond to an emergency situation

- Engine's serial number
- Description of the extent and duration of the engine operation while the Emergency SCR Derate Override was active, including a statement describing whether or not the Override was manually deactivated after the emergency situation ended

In no event may this report be submitted to John Deere or other qualified service provide later than 60 calendar days after the Emergency SCR Derate Override is activated.

LEGAL Notification

The following actions by the operator are an improper use of the Emergency SCR Derate Override and are prohibited by the Clean Air Act and US EPA regulations:

- Activating the Emergency SCR Derate Override for something other than a qualified emergency situation;
- Failing to disable the Emergency SCR Derate Override after a qualified emergency situation ends; and,
- Failing to notify John Deere and send it reports as required in this Operators Manual and federal regulations. Note: John Deere is required to report to the US EPA the operator's failure to report to it any Emergency SCR Derate Override event (to the extent it becomes aware of such event).

The maximum civil penalty the US EPA may assess under 40 CFR 1068.101 is \$4,454 for each day an engine or piece of equipment is operated in violation of the requirements associated with the Emergency SCR Derate Override.

US EPA regulations governing the Emergency SCR Derate Override can be found at 40 CFR §1039.665, as may be amended.

DX,SCR,EMRGNCY,OVERIDE,US-19-24JAN18

Fuel and Diesel Exhaust Fluid (DEF) Level Gauges

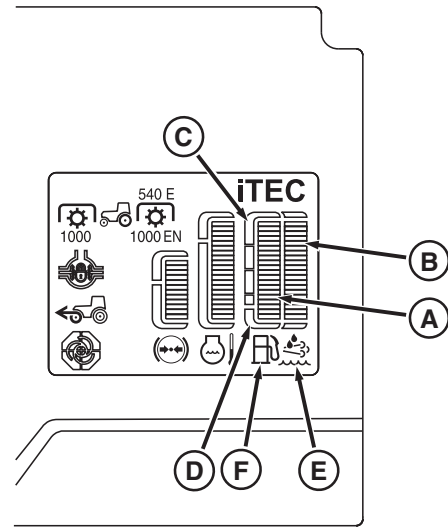

RXA0180983—UN—19FEB21

Fuel and DEF Gauges

- A—Fuel Level Gauge
- B—Diesel Exhaust Fluid (DEF) Gauge
- C—Normal Fuel and DEF Level
- D—Low Fuel and DEF Level
- E—DEF Indicator
- F—Fuel Indicator

Fuel level gauge (A) and DEF gauge (B) are a quick visual check for the operator. Fuel indicator (F) and DEF indicator (E) flash and an alarm goes off when either level is getting low. The information display shows a code when the fuel or DEF level is low as well.

Normal Fuel and DEF Level (C):

When fuel and DEF levels are in the normal-level range, indicators (E and F) illuminate white and machine operates normally. Always keep level within this range for uninterrupted performance.

Low Fuel and DEF Level (D):

When fuel and DEF levels fall into the low-level range, indicators flash amber, diagnostic trouble codes are displayed, and an alarm goes off. Fuel and DEF must be filled to continue normal operation.

When fuel and DEF levels approach zero, indicators illuminate amber continuously, diagnostic trouble codes are displayed, and an alarm goes off. If the DEF tank is not refilled immediately, engine power and speed derates. DEF must be refilled and machine must be restarted to return to normal operation.

DEF at Low Temperatures:

DEF freezes at -11°C (12°F) and its flow to the SCR system stops. Machine senses low temperature and allows engine to start and run with no DEF flow. Engine

coolant is used to thaw the DEF tank when engine is running. If DEF has thawed and SCR system is operating normally within 40 minutes, machine operation continues. If DEF flow is not sensed in 40 minutes, a diagnostic trouble code is displayed and a 4-hour internal timer starts. After 4 hours, engine power and speed derate.

D3K5H22,00005B4-19-12APR21

Fill Fuel Tank

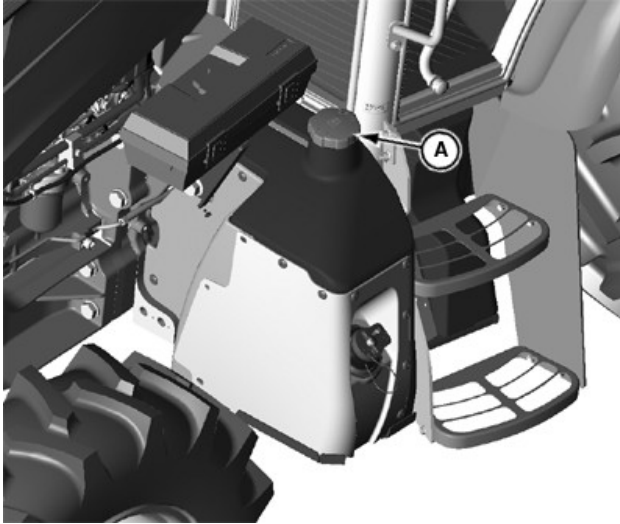

A—Fuel Fill Cap

LV22153—UN—18JUN14

CAUTION: See the Safety Precautions section at the beginning of this manual for information about handling fuel.

IMPORTANT: To avoid damage to the fuel system, never put Diesel Exhaust Fluid (DEF) into the fuel tank.

1. Watch fuel level gauge during operation.
2. Fill if necessary during daily operation. Fill fuel tank at end of each day to prevent moisture condensation in the tank.
3. Clean the area around the fuel fill cap (A) before removing.

NOTE: If the fill cap is locking, it must be unlocked before removing and relocked after reinstalling.

4. Rotate the fuel fill cap counterclockwise and remove it.
5. Fill tank with ultra low sulfur diesel fuel.
6. Reinstall fuel fill cap and rotate clockwise until secured.

GS25068,00053A3-19-18SEP18

Fill Diesel Exhaust Fluid (DEF) Tank

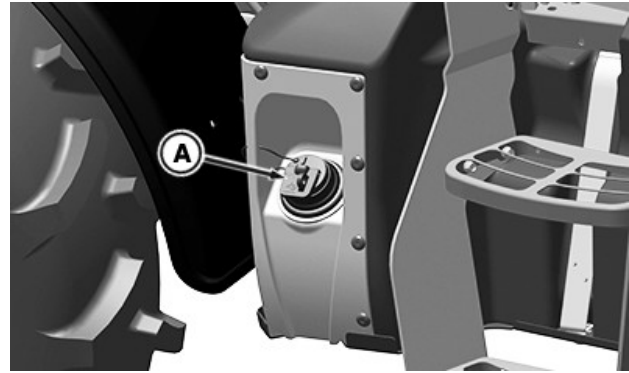

RXA0157950—UN—03MAR17

A—DEF Fill Cap

CAUTION: Diesel Exhaust Fluid (DEF) contains urea. Avoid contact with eyes. In case of contact, immediately flush the eyes with a lot of water for a minimum of 15 minutes.

Do not ingest DEF. In the event DEF is ingested, contact a physician immediately.

Refer the Materials Safety Data Sheet (MSDS) for additional information.

IMPORTANT: Only use DEF at full concentration to fill the tank. If DEF is diluted or another fluid is used, the engine detects an abnormal condition. The engine is derated and performance is reduced.

Use only distilled water to rinse components that are used to deliver DEF. Tap water can contaminate DEF. If distilled water is not available, rinse with clean tap water, then thoroughly rinse with ample amounts of DEF.

If DEF is spilled or contacts any surface other than the storage tank, immediately clean the surface with clear water. DEF is corrosive to painted and unpainted metallic surfaces and can distort some plastic and rubber components.

If DEF is filled into the engine fuel tank or other fluid compartment, do not operate engine until system is properly purged of DEF. Contact your John Deere dealer immediately to determine how to clean and purge the system.

1. Observe the Diesel Exhaust Fluid (DEF) gauge during operation.
2. Fill DEF when the fuel is refilled or if the level runs low during operation.
3. Clean area around the DEF fill cap (A) before removing.
4. Lift DEF cap latch lever, then rotate 1/4 turn counterclockwise.

5. Remove the DEF fill cap from the tank.
6. Consider the air temperature before filling the DEF tank.

IMPORTANT: Avoid overfilling the DEF tank in cold weather. DEF freezes at temperatures below -11°C (12°F). The DEF tank has a heater which cannot thaw if the tank is overfilled.

7. Fill the tank using a clean funnel.
8. Reinstall DEF tank cap. Rotate cap latch lever 1/4 turn clockwise or until secure. The DEF tank cap can be locked with a padlock.
9. Clean up any spilled DEF fluid with clean water (distilled if possible).

D3K5H22,00005BA-19-13APR21

Reduce Fuel Consumption

Fuel consumption reduction guidelines:

- Replace air cleaner, fuel, engine oil, and transmission/hydraulic filter elements at specified service intervals, see *Maintenance Intervals* section. More frequent maintenance is necessary in extreme operating conditions. If display indicates a service required condition, correct as soon as possible to improve the performance.
- Use recommended oils and lubricants only, see *Fuel, Lubricants, and Coolants* section.
- Adjust the hitch functions for most efficient operation, see *Hitch and Drawbar Operation* section.
- Check tires for correct pressure weekly, see *Wheels and Tires Maintenance* section.
- Ballast the machine for conditions, see *Ballasting* section.
- Select the correct gear. Always drive in the highest possible gear with reduced engine speed. For normal or heavy work, choose a gear so the engine speed drops 150-250 rpm when machine is operating and engine is under load. For light work, reduce engine

speed below 2000 rpm. Select gear so that engine speed drops 200—300 rpm while operating.

D3K5H22,00005B5-19-12APR21

Engine Menu

NOTE: For additional navigation information, see Basic Menu Navigation in the Displays, Software, and Electronics Operation section.



Engine Menu

RXA0152958—UN—21JUL16

1. Locate the engine menu.



Auto Filter Cleaning Selection

RXA0152960—UN—21JUL16

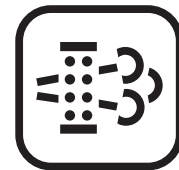

Filter Cleaning Selection

RXA0152961—UN—21JUL16

2. Select and change the desired settings as needed. (See Engine Filter Cleaning Overview in this section for additional details on settings.)

Selection	Range	Engine Response
Auto Filter Cleaning	Automatic Cleaning or Cleaning Disabled	Automatic cleaning allows exhaust filter cleaning to occur during operation if certain conditions are met. Cleaning disabled prevents automatic cleaning. When the engine is cycled off, it defaults back to automatic.
Filter Cleaning	Parked Filter Cleaning	If the symbol is not grayed out, a parked filter cleaning can be performed.

D3K5H22,0000595-19-30MAR21

Exhaust Filter Cleaning Overview

Overview:

IMPORTANT: The area over and surrounding the engine during a manual exhaust filter cleaning must be free of any flammable objects. Exhaust reaches temperatures as high as 550°C (1022° F).

The exhaust filter requires maintenance periodically. Some of the maintenance is transparent to the operator. During continuous heavy loads and other conditions, the engine creates enough heat to remove accumulated soot in the exhaust filter naturally.

When the exhaust filter has accumulated higher levels of soot, the display requests an exhaust filter cleaning. During this request, the equipment must be located in or moved to a suitable location with adequate ventilation. Engine speed must be kept above 1200 rpm and filter cleaning must be allowed to finish uninterrupted. If using the machine to perform work while filter cleaning occurs, there is little to no noticeable impact on the application in most cases.

The symbols that appear on the operator interface are shown. These symbols appear within the information and primary displays.

In addition to the symbols, there are notifications, alarms, and diagnostic trouble codes associated with exhaust filter cleaning. These messages appear on the information display to make the operator aware.

Emission System Temperature/Filter Cleaning Indicator:

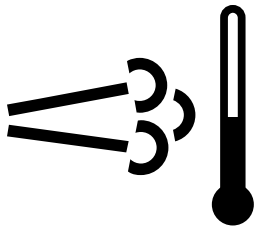

H94829—UN—13OCT09

Emission System Temperature/Filter Cleaning Symbol

This indicator appears on the primary display as a lighted icon. When this icon is illuminated, the emission system temperature is high enough to allow an automatic filter cleaning to occur, or a filter cleaning is occurring.

Automatic exhaust filter cleaning is started when sulfur or urea deposits in the exhaust filter reach a certain level and the engine speed is above 1200 rpm. Engine system temperature/filter cleaning symbol remains illuminated during the exhaust filter cleaning. Automatic exhaust filter cleaning is initiated and performed without any intervention on the part of the operator.

Auto Filter Cleaning Icon:



RXA0152960—UN—21JUL16

Auto Filter Cleaning Selection

This icon is found in the engine menu on the information display. Changes to this setting will reduce machine performance over time. Selecting this option in the engine menu allows the operator to choose between “Automatic Cleaning” and “Cleaning Disabled.”

Leave the setting at “Automatic Cleaning” at all times unless a condition exists where high exhaust temperatures are unacceptable. Each time the key is cycled off, the setting reverts to automatic cleaning.

CAUTION: Under certain circumstances, high exhaust temperatures associated with exhaust filter cleaning could pose a risk, such as causing a fire. Changing the setting to “Cleaning Disabled” may be desirable for certain applications. Operations connected to exhaust duct work, in confined spaces, working close to combustible materials, and others should be considered.

IMPORTANT: Repeatedly disabling the filter cleaning process leads to reduced engine performance and requires a parked exhaust filter cleaning more frequently.

NOTE: For additional display navigation information, see *Basic Menu Navigation in the Displays, Software, and Electronics Operation* section.

Filter Cleaning Icon:

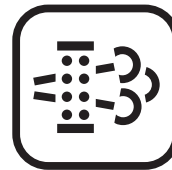

RXA0152961—UN—21JUL16

Filter Cleaning Selection

IMPORTANT: If operator disregards indicators and continues to operate machine without allowing an automatic cleaning, engine performance is reduced. A parked exhaust filter cleaning procedure must be performed. Continued disregard requires a John Deere dealer to perform a service exhaust cleaning procedure.

This icon is found in the engine menu on the information display. When allowed, a parked filter cleaning can be performed through this menu. If the exhaust filter has not been allowed to perform automatic cleaning on a regular basis or becomes plugged, a parked cleaning is required. If the system does not require a parked cleaning, the filter cleaning icon is unavailable to select.

Parked Filter Cleaning:

CAUTION: Parked exhaust filter cleaning creates high exhaust temperatures and takes 30—45 minutes to complete. Park machine in an area with adequate ventilation that is away from combustible materials.

IMPORTANT: Once the parked cleaning process is initiated, allow it to finish uninterrupted.

1. Check the fuel and DEF levels. Fill if needed.
2. Park the machine in a suitable space, disengage PTO and any auxiliary functions, and lower any implements all the way to the ground.
3. Set engine speed to low idle.
4. Use NO other machine functions while exhaust filter cleaning is taking place. Excluded are functions that are required for an emergency shutdown of the machine.
5. Select the “Filter Cleaning Icon” in the information display.
6. Display prompts to “Initiate Parked Filter Cleaning.” Select “Start” to begin.
7. A list of conditions to be met appears. If all of the boxes are checked, depress the confirm button on the navigation pad to begin.
8. Select “Next” and depress the confirm button again to initiate.
9. Allow the process to run without interruption. Engine speed increases without any input from the operator. A progress bar shows on the information display during the process.
10. An “Exhaust Filter Cleaning Complete” message appears if the process is successful. Select “OK” to leave the menu.
11. If the process does not complete, an error message appears related to one of the following conditions:
 - a. Speed control was not set to low idle.
 - b. Machine was not in park and wheel speed was detected.
 - c. PTO speed was detected.
 - d. Filter cleaning could not be completed. If this error occurs, it is recommended to take the machine to your John Deere dealer for service.

12. Continue machine operations as normal.

NOTE: If not returning machine to operation, allow engine time to return to normal operating temperature before stopping engine.

Service Exhaust Filter Cleaning

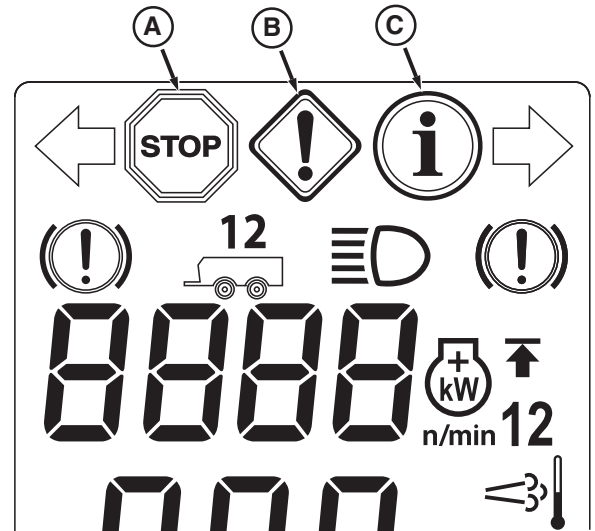

RXA0180999—UN—22FEB21

Warning Indicators

- A—STOP Indicator
- B—Warning Indicator
- C—Information Indicator

IMPORTANT: Do not repeatedly cancel or ignore STOP indicator (A), warning indicator (B), or information indicator (C). Failure to perform a requested parked exhaust filter cleaning procedure causes additional engine power limitations and eventually requires dealer service.

When STOP indicator (A) is illuminated and a corresponding emissions diagnostic trouble code occurs at the same time, contact your John Deere dealer.

Tips for avoiding service cleaning:

- Use ultra-low sulfur fuel.
- Avoid unnecessary idling.
- Avoid disabling exhaust filter cleaning unless it is necessary.
- Avoid interrupting cleaning process unless it is necessary.
- If possible, do not turn off the engine while the exhaust filter indicator light is on.

- Take note of information displayed for the operator and act accordingly.

D3K5H22,00005CC-19-17MAY21

Electrical and Lighting Operation

Battery Disconnect Switch

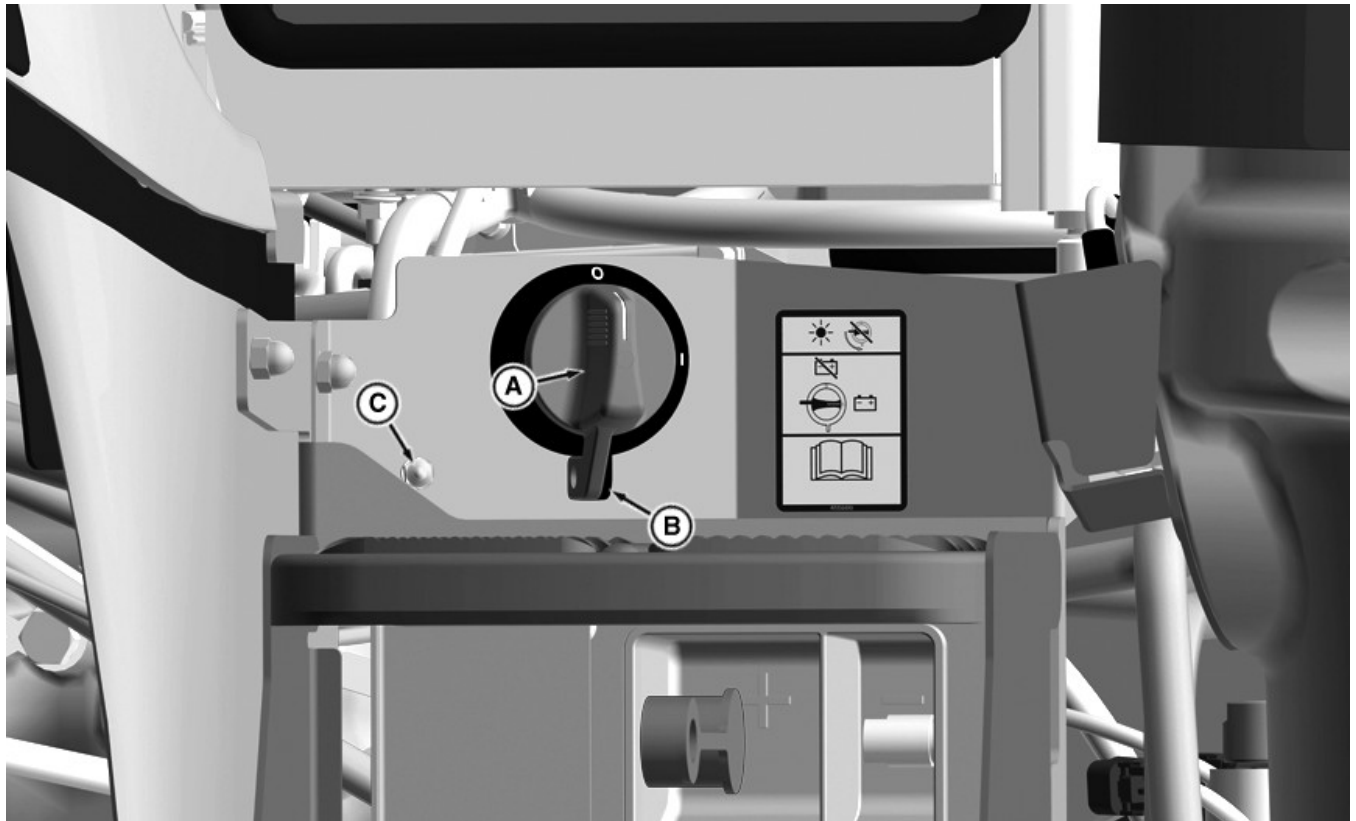

RXA0164939—UN—31OCT18

A—Battery Disconnect Switch
B—Lock Tabs

C—Battery Disconnect Indicator Light

CAUTION: Never switch off power at battery while engine is running! Damage to machine electronics is possible and voltage peaks at alternator can be dangerous.

IMPORTANT: When storing for long periods of time, turn battery disconnect switch to the off position (machine electrical system disconnected from battery power supply). Battery discharges if machine is not used and battery disconnect is in on position.

NOTE: Wait at least 4 minutes after turning off engine to activate battery disconnect switch or to disconnect the battery cables for any reason.

The battery disconnect switch prevents power from reaching the rest of the electrical system. To disconnect the battery:

1. Turn the ignition switch to the Off position and remove the key.
2. Wait 4 minutes or until the LED indicator light located next to the battery disconnect switch stops blinking (if equipped).
3. Rotate the battery disconnect switch (A)

- counterclockwise to the power off position to shut the power off to the machine
4. If desired, the switch can be locked utilizing the lock tabs (B).

To restore power to the machine:

1. Unlock the battery disconnect if needed.
2. Turn the battery disconnect switch (A) clockwise to the On position.
3. Allow a minimum of 30 seconds for electronic control units to power up.
4. Insert key and start the engine.

GS25068,000577F-19-13SEP19

Light Switch

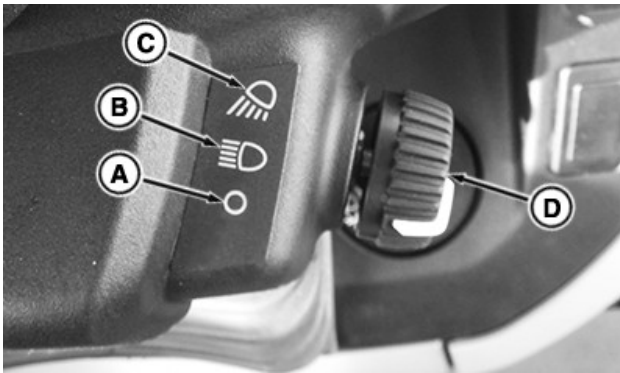

A—Off Position
B—Road Position
C—Field Position

RXA0182440—UN—14APR21

D—Light Switch

CAUTION: Use lights in road position while operating on public roadways as required by local traffic laws or regulations.

Do not operate the machine on public roadways with the light switch in field position or worklights on. Other machine operators can be blinded or confused, impairing their driving ability.

Rotate light switch (D) forward to road position (B) if operating on the road. When operating in the field, rotate the switch to field position (C) and turn on additional worklights with the appropriate worklight switch.

Switch Position	Use	Warning Lights (amber)	Tail Lights (red)	Worklights	Front Grille Headlights
A—Off	Field, Day Time	Off	Off	Off	Off
B—Road Lights	Road, Night Time	On Flashing	On	Off	On
C—Field Lights	Field, Night Time	Off	On	On	On

D3K5H22.00005C0-19-30JUN21

Headlights



LV15525—UN—05MAR12

A—Horn/Headlight Control/Turn Signal Lever B—Headlights

CAUTION: Dim headlights to low beam for oncoming vehicles. Other machine operators can be blinded or confused, impairing their driving ability.

Push lever (A) forward to illuminate high beam headlights (B). High beam indicator illuminates on the primary display. Pull lever into center position to switch to low beam lights.

Operate flash-to-pass function by pulling lever rearward and releasing momentarily to activate high beams.

Lever Position	High Beam	Low Beam
Normal (Center)	Off	On
Forward	On	Off
Rear (Flash-to-Pass)	On	On

GS25068.00053AB-19-19SEP18

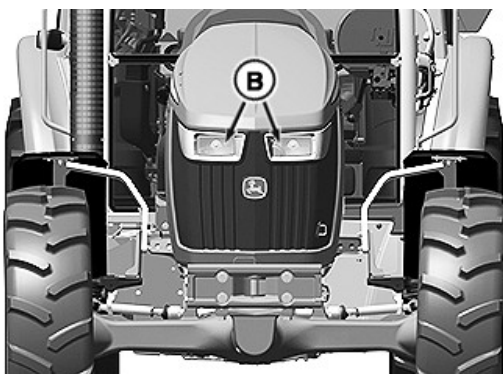

RXA0157953—UN—03MAR17

Loader Headlights

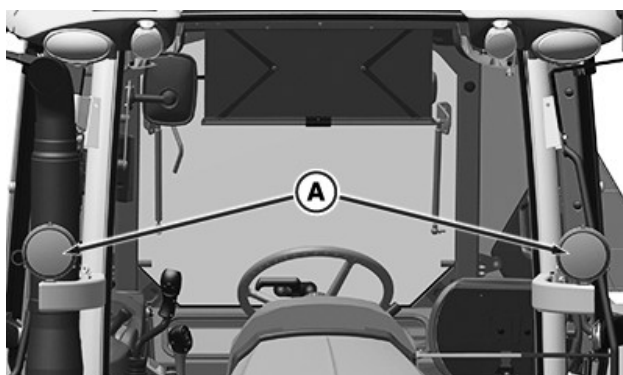

RXA0182433—UN—08APR21



RXA0181713—UN—14APR21

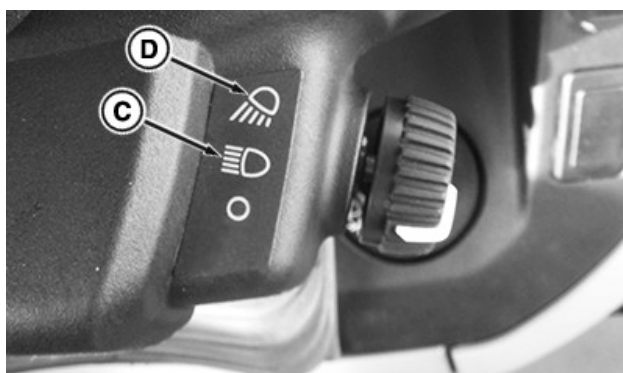

RXA0181712—UN—16MAR21

- A—Loader Headlight Assembly
- B—Loader Headlights Button
- C—Road Lights Position
- D—Worklights Position

Loader headlights can be used as an alternative for obscured driving headlights mounted in the front grille.

NOTE: Loader headlights are only available with loader.

Loader Headlight Button	Main Light Switch	Loader Headlights	Front Grille Headlights
On	C—Road	On	Off
	D—Work	On	Off
Off	C—Road	Off	On
	D—Work	Off	On

D3K5H22.00005BF-19-13APR21

Bucket Lights

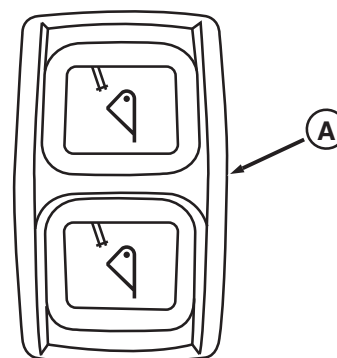

RXA0161635—UN—05JAN18

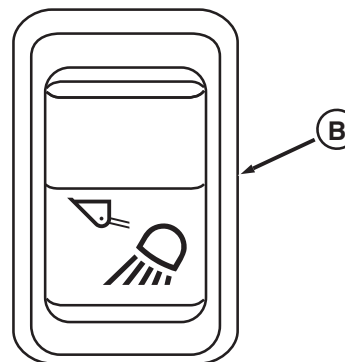

RXA0161636—UN—05JAN18

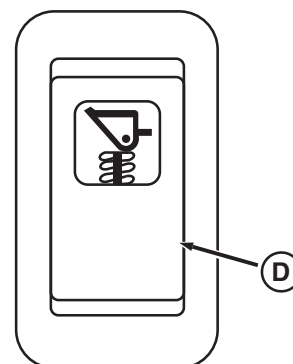

RXA0161638—UN—05JAN18

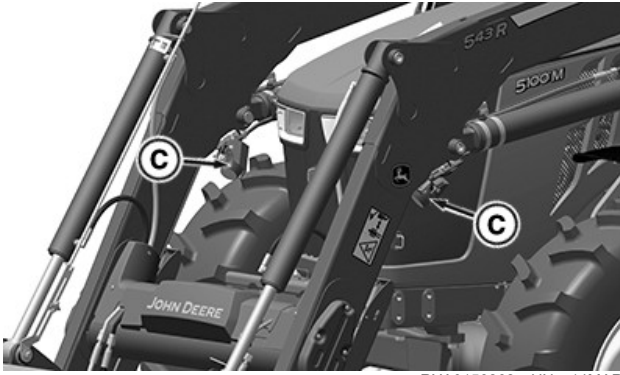

RXA0158262—UN—14MAR17

- A—Bucket Attach/Detach Switch
- B—Bucket Lights Switch
- C—Bucket Lights
- D—Loader Suspension Switch

Bucket lights (C) are on the loader mast and illuminate the bucket and contents no matter how the loader is positioned.

See relevant loader operator's manual for more information on bucket attach/detach switch (A), bucket light switch (B), and loader suspension switch (D).

D3K5H22.0000580-19-24MAR21

Tail and Brake Lights

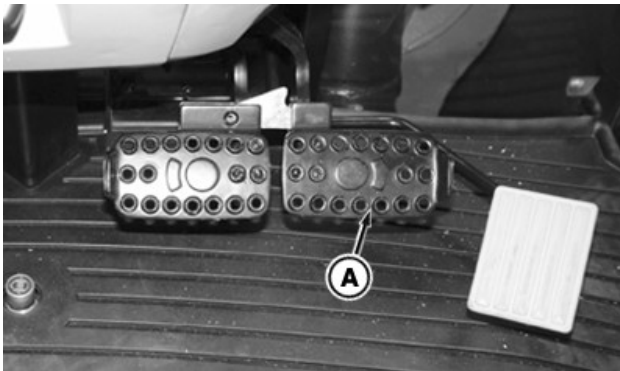

RXA0153629—UN—30AUG16

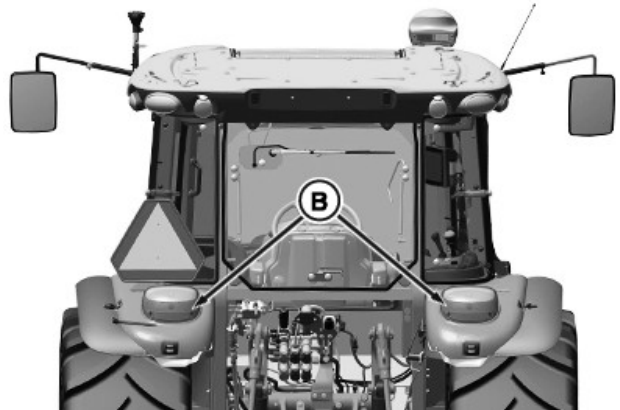

Cab

RXA0182439—UN—08APR21

- A—Brake Pedals

B—Tail and Brake Lights

Tail and brake lights (B) both illuminate using the same dual intensity bulb. When the light switch is in road position only, the tail light portion illuminates.

If one or both brake pedals (A) are depressed, the intensity of the light increases since both filaments are illuminated.

D3K5H22.00005C1-19-14APR21

Turn Signals



LV15525—UN—05MAR12

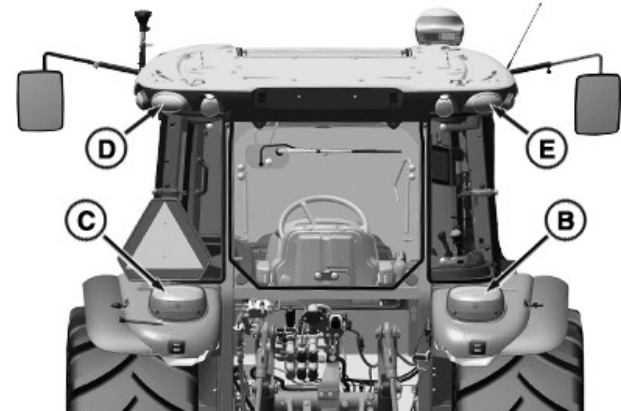

Cab

RXA0182434—UN—08APR21

- A—Horn/Headlight Control/Turn Signal Lever
- B—Right Turn Signal
- C—Left Turn Signal
- D—Left Rear Warning Lights (front similar)
- E—Right Rear Warning Lights (front similar)

CAUTION: Always use turn signals when making a turn on public roadways as required by local traffic laws or regulations.

Push lever (A) up for right turn, or pull down for left turn. Turn signal icon on primary display flashes to indicate turn signal lever and lights are on.

Return lever to center position after completing turn.

When operating on the road, warning lights must be used in conjunction with turn signals. The following table describes turn signal function based on the lever position.

Turn Signal Lever Position	Right Turn Signal (B)	Left Turn Signal (C)	Right Warning Lights (E)	Left Warning Lights (D)
Off	Off	Off	On Flashing	On Flashing
Up	On Flashing	Off	On Flashing	On Steady
Down	Off	On Flashing	On Steady	On Flashing

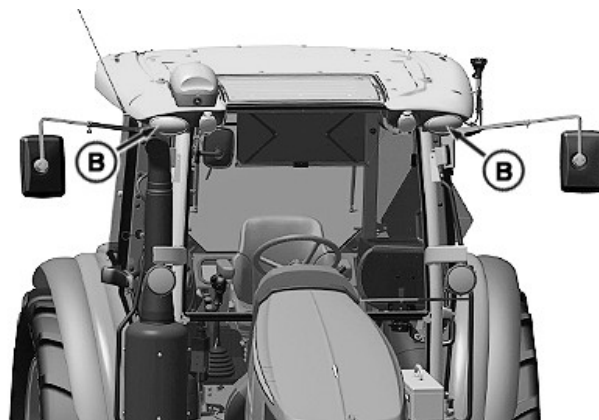

RXA0182435—UN—08APR21

When operating in the field, warning lights do not have to be used. The following table describes turn signal function without the warning lights.

Turn Signal Lever Position	Right Turn Signal (B)	Left Turn Signal (C)
Off	Off	Off
Up	On Flashing	Off
Down	Off	On Flashing

D3K5H22.00005AE-19-30MAY23



RXA0181701—UN—14APR21

Warning Lights

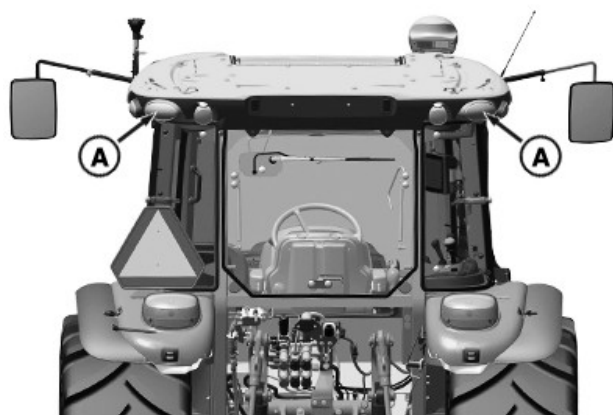

RXA0182436—UN—08APR21

- A—Rear Warning Lights
- B—Front Warning Lights
- C—Warning Lights Switch

CAUTION: Use warning lights on public roadways as required by local traffic laws or regulations.

NOTE: Warning lights operate any time light switch is in the warning position (C), regardless of key position.

Rotate light switch to warning position (C) to illuminate front (B) and rear warning lights (A). Rotate light switch to the off position to turn off warning lights.

D3K5H22.00005E6-19-27APR21

Beacon Light



RXA0182392—UN—06APR21



RXA0181703—UN—14APR21

- A—Beacon Light
- B—Beacon Light Switch

⚠ CAUTION: Use beacon light on public roadways as required by local traffic laws or regulations.

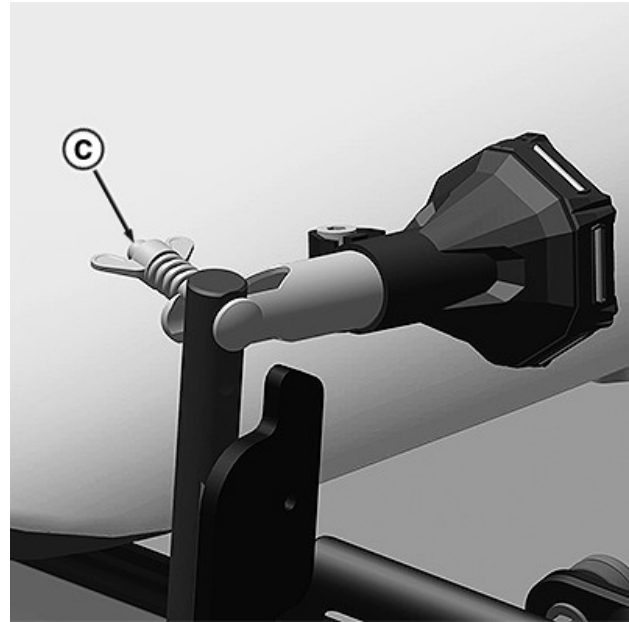

RXA0182395—UN—07APR21

1. Depress beacon light switch (B) to activate beacon light (A).
2. To prevent damage, loosen wing nut (C) and tilt beacon light assembly forwards or backwards when needed.

D3K5H22,00005AB-19-06APR21

Worklights

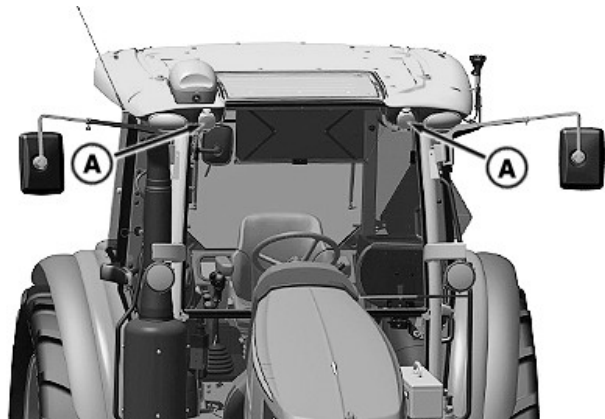

RXA0182437—UN—09APR21

Front Worklights

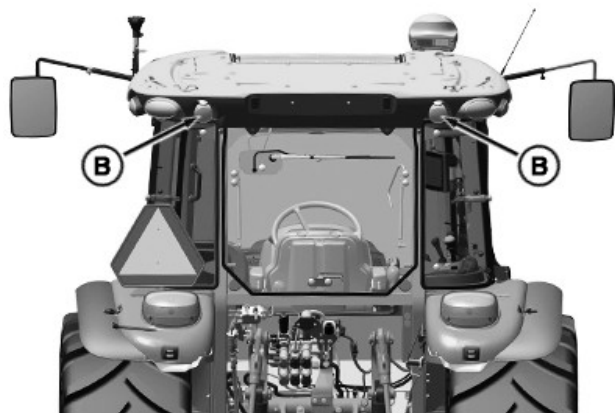

Rear Worklights

RXA0182438—UN—14APR21

⚠ CAUTION: Do not use worklights on public roadways unless allowed by local traffic laws or regulations.

NOTE: Cab is shown with two front worklights. Two additional front worklights can be added and work in conjunction with the two shown.

Rotate light switch to field position (D) to illuminate front worklights (A), rear worklights (B) and side worklights (C).

D3K5H22.00005C2-19-14APR21

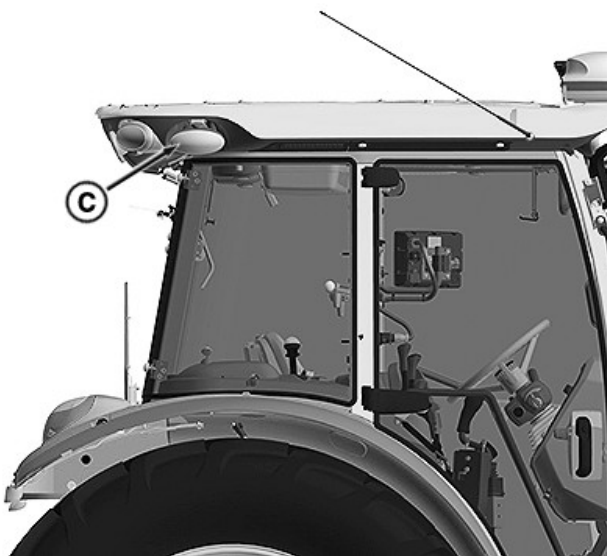

Side Worklights (right-hand side shown; left-hand side similar)

RXA0182442—UN—14APR21

Dome Light



A—Dome Light Switch

LV8418—UN—14JUL03

IMPORTANT: Before exiting cab, turn dome light to Off or Door position to avoid causing battery to lose its charge.

Dome light switch (A) has three positions:

- Left (on) - light always on.
- Right (door) - light on with door open or light off with door closed.
- Center (off) - light always off.

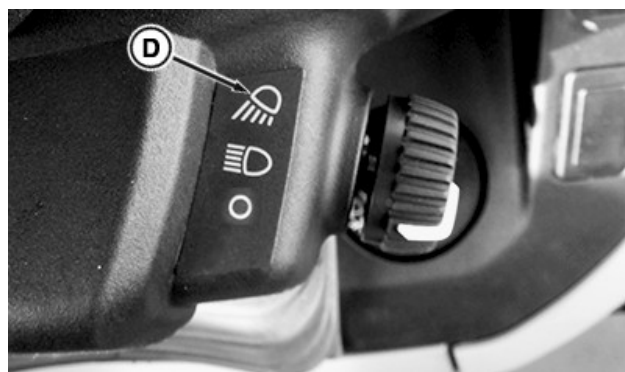

Front Worklight Position

RXA0182441—UN—14APR21

DP51502.0002A30-19-31JAN17

- A—Front Worklights
- B—Rear Worklights
- C—Side Worklights (right-hand side shown; left-hand side similar)
- D—Field Position

Map Light

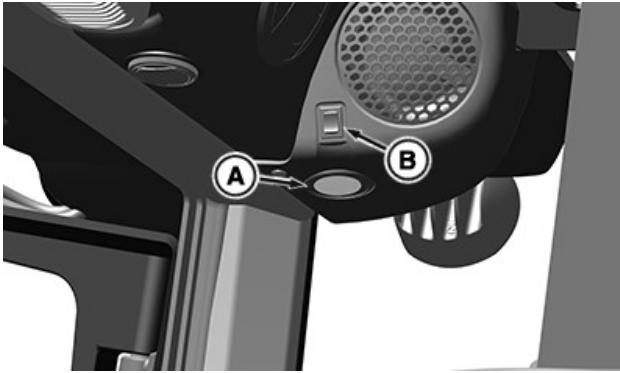

RXA0153617—UN—29AUG16

A—Map Light
B—Map Light Switch

For added illumination inside the cab, push map light switch (B) to turn on map light (A).

D3K5H22.0000578-19-17MAR21

The right-hand console light (A) is only on when the light switch (B) is in road or field positions.

D3K5H22.00005C3-19-15APR21

Horn



LV15525—UN—05MAR12

A—Horn/Headlight Control/Turn Signal Lever

Push in on end of lever (A) to sound horn.

D3K5H22.00005AC-19-07APR21

Right-Hand Console Light

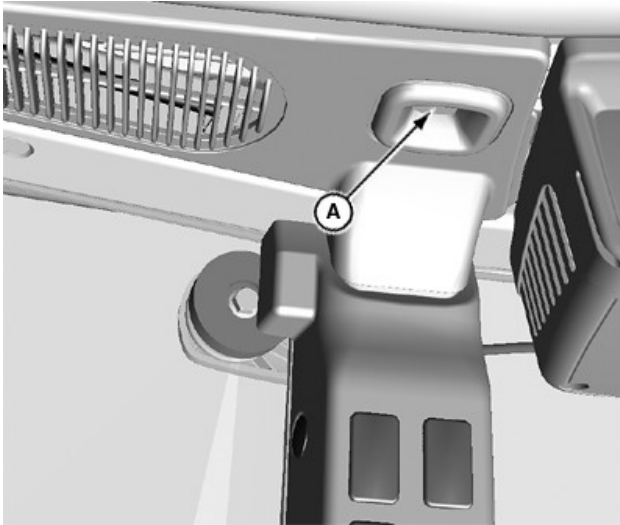

LV21961—UN—30MAY14



RXA0182443—UN—15APR21

A—Right-Hand Console Light
B—Light Switch

Backup Alarm

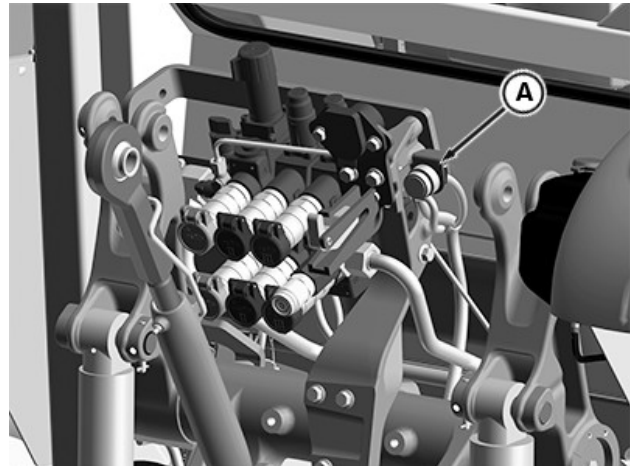

PY42054—UN—14MAY17

A—Backup Alarm

Backup alarm (A) sounds when the key switch is in the on position and the left-hand reverser lever or range shift lever is in reverse position.

Backup alarm beeps to alert anyone near that machine is traveling in reverse.

PB32103.0000479-19-14MAY17

Front Wiper and Washer

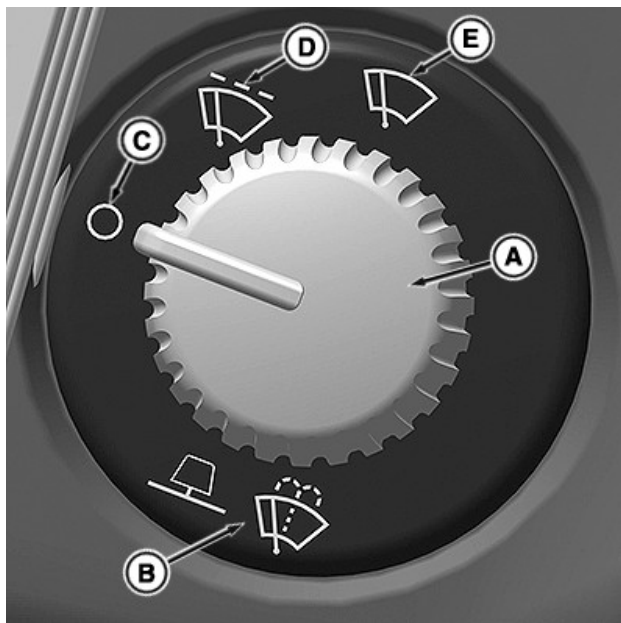

RXA0181714—UN—17MAR21

- C—OFF
- D—Slow
- E—Fast
- F—Front Wiper
- G—Washer Fluid Reservoir

Wiper/washer knob (A) has three positions:

- OFF (C)
- Slow (D)
- Fast (E)

Rotate knob forward (clockwise) to increase speed of front wiper (F). Rotate rearward (counterclockwise) to slow or shut off. Push knob inward to operate front washer (B).

Washer fluid reservoir (G) is located behind the right-hand cab corner. Fill reservoir with windshield washer fluid as required. In cold climates, fill with non-freezing windshield washer fluid. Reservoir supplies both the front and rear wipers.

D3K5H22.0000586-19-24MAR21

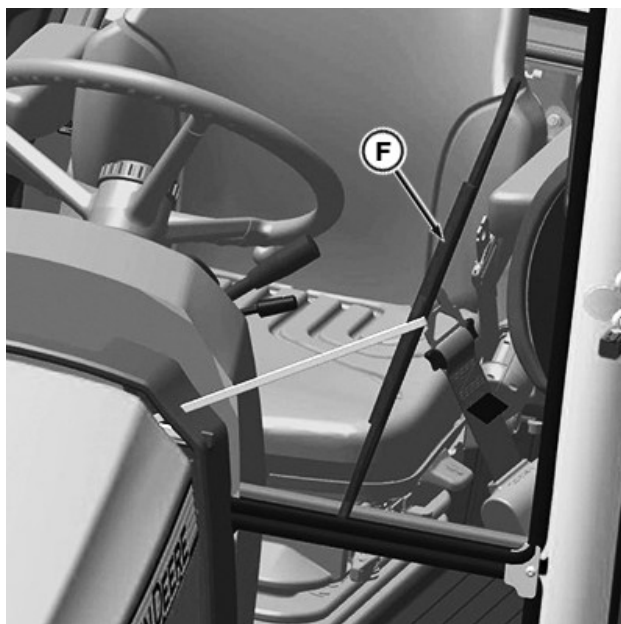

RXA0181715—UN—17MAR21

Rear Wiper and Washer



LV14518—UN—02AUG11

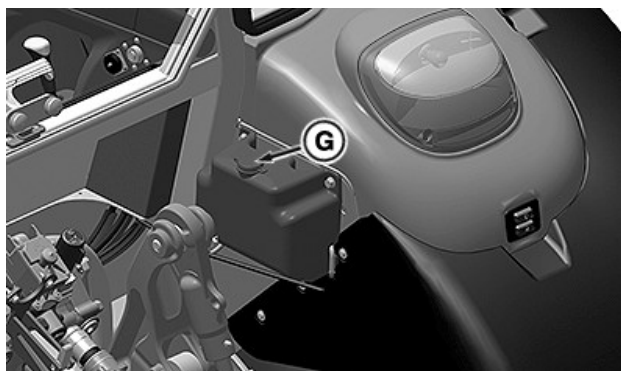

RXA0158255—UN—14MAR17

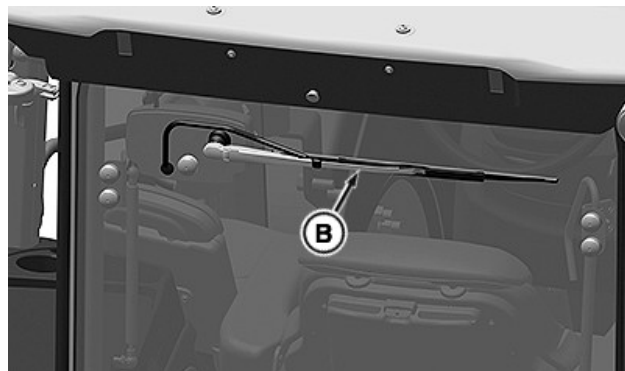

RXA0153610—UN—30AUG16

A—Front Wiper/Washer Knob
B—Washer

A—Rear Wiper/Washer Switch
B—Rear Wiper

Rear wiper/washer switch (A) has three positions:

- Top - washer and wiper on.
- Center - wiper on.
- Bottom - all off.

Place the switch in center position to operate the rear wiper (B). Place in top position to operate the washer and wiper at the same time.

MP60050,00009A4-19-10MAR17

Refer to your specific radio reference manuals for more information about operation.

MP60050,00009A6-19-10MAR17

Radio



RXA0153726—UN—31AUG16

A—Radio

Refer to your specific radio reference manuals for more information about operation.

DP51502,0002A38-19-31JAN17

Bluetooth Microphone

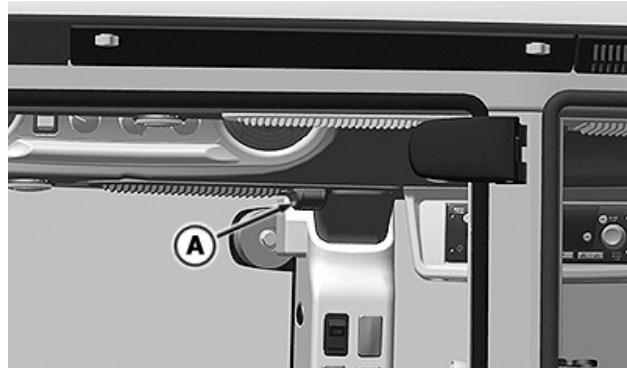

RXA0182561—UN—29APR21

A—Bluetooth Microphone

A mobile phone can be paired with the premium radio. The Bluetooth microphone (A) is maintenance-free and requires no adjustment. See radio operator's manual for procedure to pair the specific mobile device with the premium radio.

D3K5H22,00005E7-19-26JUL21

Auxiliary Input and USB Port

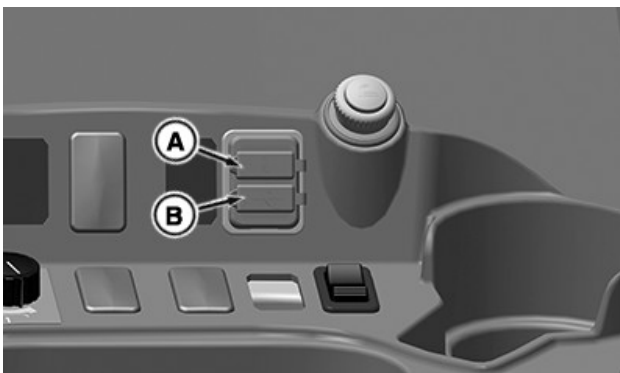

RXA0158256—UN—14MAR17

A—Auxiliary Input
B—USB Port

Different external audio sources can be connected to the auxiliary input (A).

USB port (B) allows operator to connect data transfer devices to the radio.

Speakers



RXA0181003—UN—02MAR21

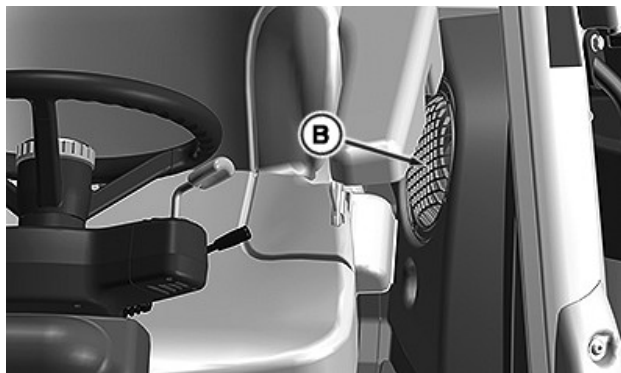

RXA0158646—UN—02MAY17

- A—Front Speaker (2)
- B—Subwoofer

Front speakers (A) are located above the front windshield. Subwoofer (B) is located in the left-hand rear corner of the cab.

D3K5H22,00005D9-19-22APR21

Radio Antenna

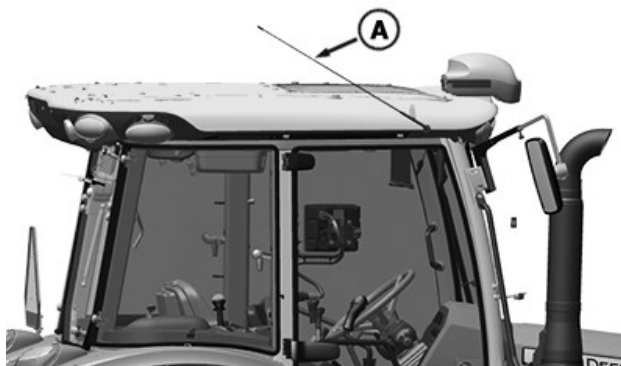

RXA0182560—UN—29APR21

- A—Radio Antenna

Adjust radio antenna (A) as required to improve radio reception.

D3K5H22,00005E8-19-29APR21

Satellite Module and Antenna

Satellite is available to improve radio and communication reception. This feature requires no operator interaction and is not visible to the operator. Satellite service provides reception and communications when other services are not available.

Refer to your specific radio reference manuals for more information about operation.

DP51502,0002A3D-19-31JAN17

Implement Connector

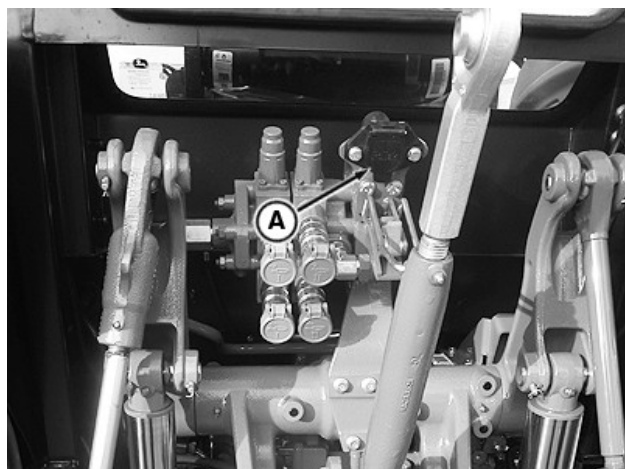

PY39990—UN—10MAY17

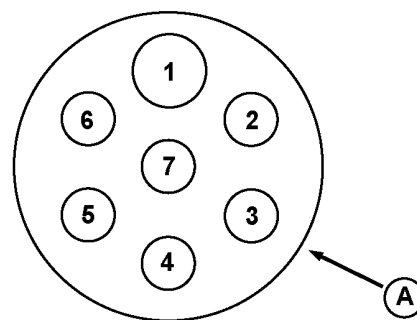

RW21249A—UN—29APR99

Connector Terminals

- A—Implement Connector

NOTE: Matching 7-pin plug is available through your John Deere dealer.

Rear-mounted implement connector (A) is used to connect lights, turn signals and other remote trailer or implement electrical equipment to the machine electrical system.

Terminal Number	Function
1	Ground
2	Implement Worklights
3	Left Turn Signal
4	Brake Lights
5	Right Turn Signal
6	Tail Lights
7	Accessory Power

Always use auxiliary light on towed implement when machine rear signals and other lights are obscured.

GS25068,00053B0-19-19SEP18

Power Outlet



RXA0158293—UN—14MAR17

A—Power Outlet

Power outlet (A) is an accessory 12 V electrical outlet for connecting auxiliary equipment. Outlet is protected by a 30 amp fuse.

An optional cigarette lighter can be installed in place of the power outlet.

D3K5H22,00005DA-19-22APR21

For additional information on connections, see auxiliary equipment installation instructions or your John Deere dealer.

MP60050,00009AC-19-04APR17

Auxiliary Power Strip



RXA0153603—UN—29AUG16

Convenience Outlets



RXA0158294—UN—14MAR17

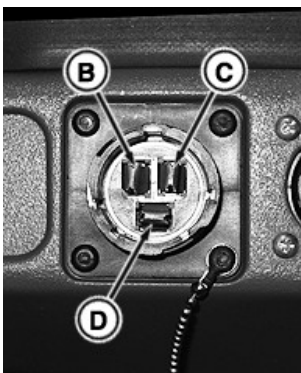

RXA0153624—UN—30AUG16

- A—Convenience Outlet
- B—Battery Power (Unswitched)
- C—Battery Power (Switched)
- D—Ground

Convenience outlet (A) is on the right-hand console and is used when connecting auxiliary equipment.

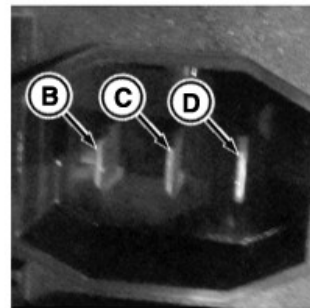

RXA0131998—UN—06MAY13

- A—Auxiliary Power Strip
- B—Battery Power (Unswitched)
- C—Ground
- D—Battery Power (Switched)

IMPORTANT: Power strip is not a surge suppressor. Electrical equipment with program memory requires protection from damage of electrical surges and spikes.

Power strip (A) provides six 12-volt grounded power outlets connecting auxiliary equipment.

Positive symbol (+) on the cover indicates that circuit is unswitched (B). Negative symbol (-) on the cover indicates the circuit ground (C). Circle symbol (O) on the cover indicates that circuit is switched (D). Outlets are protected by a 30 amp fuse.

Various adapters are available from your John Deere dealer. Adapters plug directly into the power strip. To change to switched power on adapter, remove the small tab at end of the slot on plug and rotate plug 180°.

D3K5H22,00005DB-19-22APR21

ISO Cab Connectors

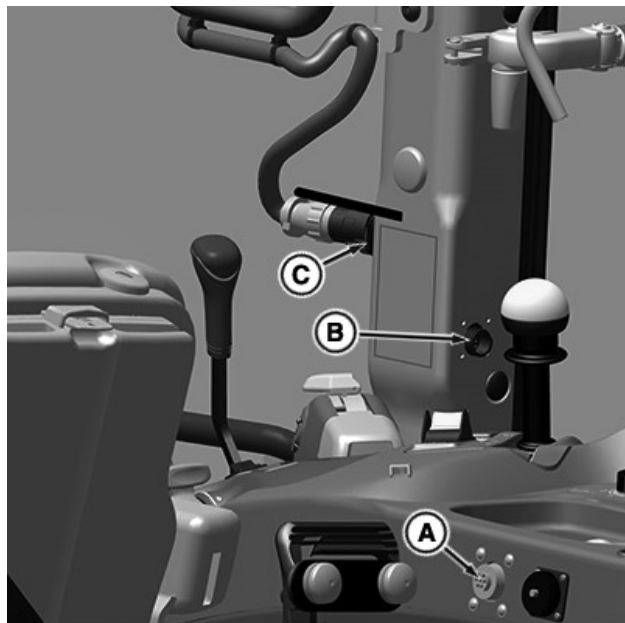

RXA0181707—UN—10MAR21

- A—ISO11786 Connector
- B—ISO11783 Connector—ISOBUS In-Cab Connector
- C—GreenStar Display Connector

IMPORTANT: Only connect ISO11786 and ISO11783 compliant devices to each specific connector, otherwise machine damage occurs.

Machine is ISOBUS ready and offers a connection for implements conforming to ISO11783 standards.

Machine also offers a connection conforming to ISO11786 standards.

ISO11786 connector (A) and ISO11783 connector (B) are used to connect to third-party controls. Refer to the third-party information for using equipment attached to the connector.

GreenStar Display connector (C) allows any GreenStar Display connection. See your John Deere dealer for compatible adapter harnesses.

MP60050,0000AFD-19-19MAY21

ISOBUS Connectors

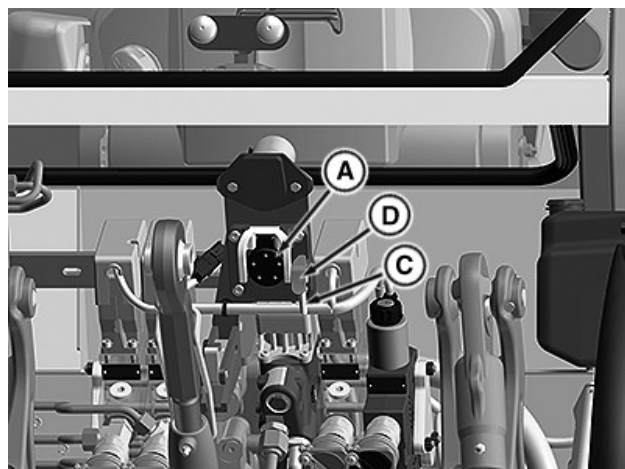

RXA0164098—UN—08AUG18

Rear ISOBUS Connector

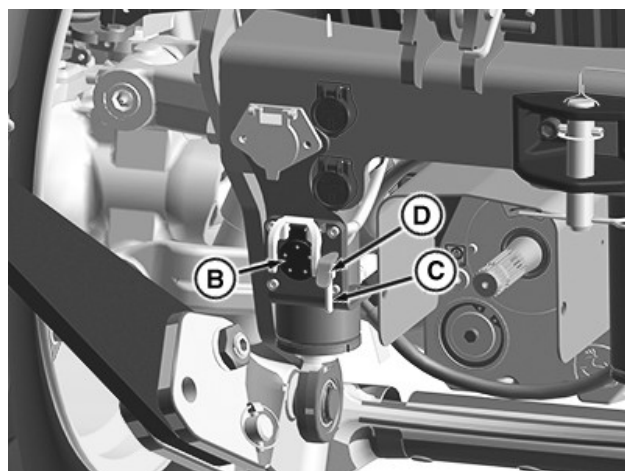

RXA0164099—UN—08AUG18

Front ISOBUS Connector

- A—Rear ISOBUS Connector
- B—Front ISOBUS Connector
- C—Handle
- D—Release

ISOBUS ready preparation includes ISOBUS implement connector (A or B) on machine front or rear, facilitating machine/implement communications.

Lift handle (C) to open cover and connect implement harness. Lift the release (D) when disconnecting implement harness from connector (A or B) on machine front or rear.

GS25068,00050DD-19-22AUG18

ISOBUS Shortcut Button (ISB)

In an ISOBUS system, operator can activate function of implement over ISOBUS via implement's operator interface on display. See ISOBUS controller operator's manual.

After activation, operator can change screen of display

in order to operate another implement or interact with other applications.

Deactivation of functions on first implement is not possible unless operator manually switches back to corresponding screen of first implement. ISB provides a direct method to inform all ISOBUS participants about operator's desire to deactivate functions that were activated by an ISOBUS control.

⚠ CAUTION: Read appropriate operator's manual. ISB button function is proprietary to implement manufacturer. Verify button function in a safe and open area that is clear of bystanders.



RXA0181709—UN—10MAR21

A—ISOBUS Shortcut Button

ISOBUS Shortcut Button (ISB): Pressing ISB (A) sends “Stop All Implement Operations” signal out on ISOBUS. Reaction to ISB is proprietary to receiving control unit.

D3K5H22,000058B-19-24MAR21

A—Service Advisor Connector

IMPORTANT: Connector is to be used only for Service Advisor equipment, otherwise machine damage occurs.

The Service Advisor connector (A) is used by your John Deere dealer to diagnose and repair the machine.

MP60050,0000AFE-19-19MAY21

Operator Presence

⚠ CAUTION: When the operator leaves the seat, the PTO and/or SCVs do not automatically disengage. The machine can move if operator leaves the seat and the transmission is not in Park.

Do not tamper with or disable the operator presence switch to ensure that machine operates correctly.

All operator seats have a switch to detect that the operator is present during operation.

GS25068,0003EC0-19-06FEB18

JDLink

JDLink is an option which allows machine tracking and data collection through cellular or satellite communications.

See JDLink reference manuals for more information on the available options, installation, operation, and maintenance.

MP60050,0000AFF-19-19MAY21

Service Advisor Connector

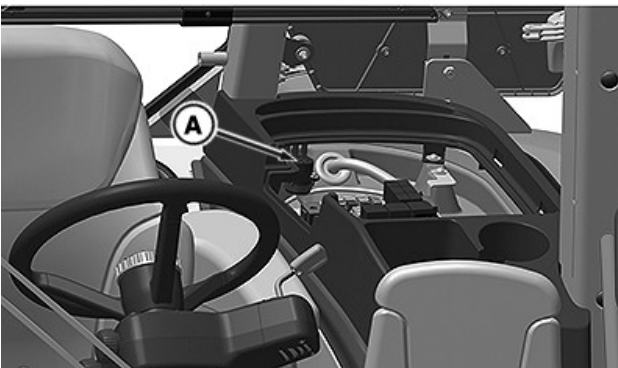

RXA0153612—UN—29AUG16

Displays, Software, and Electronics Operation

Primary Display

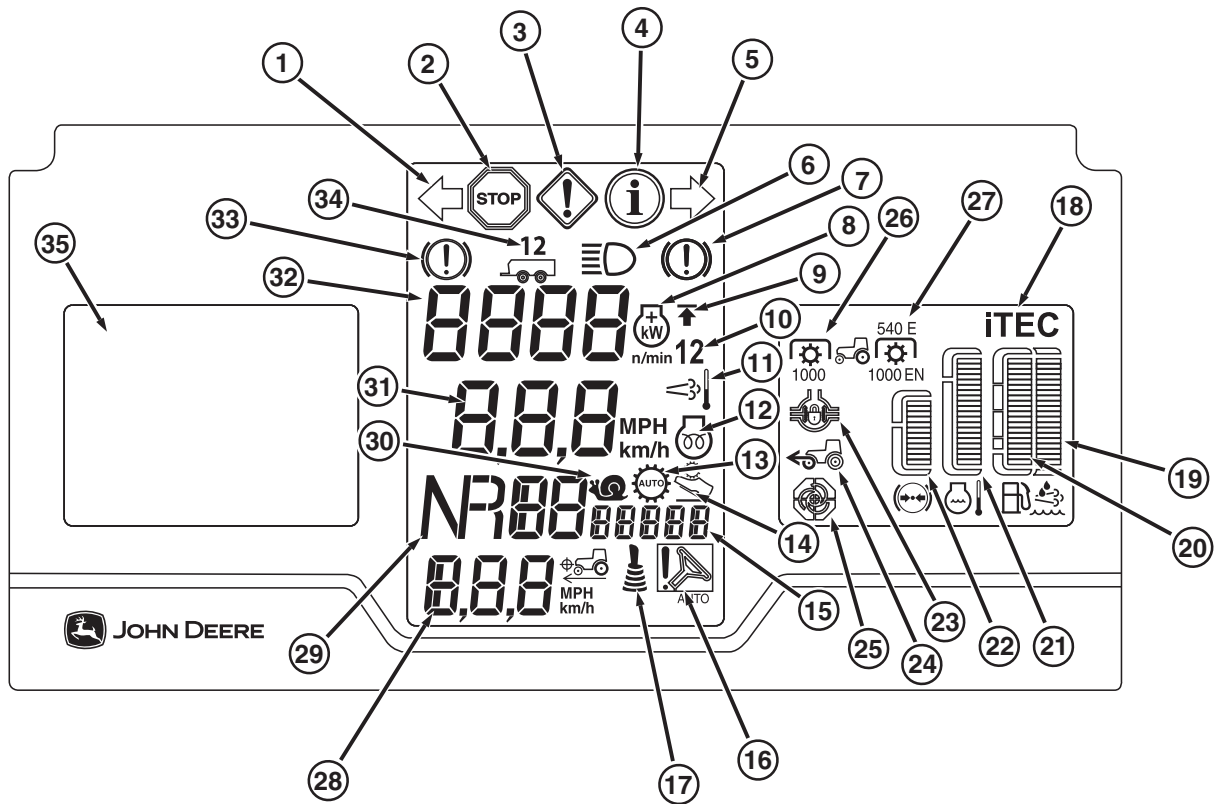

RXA0180927—UN—20APR21

Display Icon	Icon Name	Icon Description
1	Left Turn	Flashes when turn signal switch is switched to the left-hand side.
2	Stop	Illuminates when a serious malfunction occurs. SHUT OFF engine IMMEDIATELY and determine cause (review error message on information display). If necessary, have your John Deere dealer diagnose machine.
3	Service Alert	Illuminates when a malfunction occurs (review error message in information display). If necessary, have your John Deere dealer diagnose machine.
4	Information	Illuminates when a possible fault condition has been detected. Monitor machine for potential problems.
5	Right Turn	Flashes when turn signal switch is switched to the right-hand side.
6	High Beam	Illuminates when the headlights are switched to high beam.
7	Brake System Warning	Illuminates when a brake system malfunction occurs. Brake system does not perform as expected. Have John Deere dealer diagnose machine.
8	Intelligent Power Management	Illuminates when controlled engine power boost is active.
9	FieldCruise (Not used)	Illuminates when maximum set speed is active.
10	FieldCruise Selection (Not used)	Illuminates which maximum set speed setting is activated at the current time.
11	Exhaust Filter Cleaning	Illuminates when exhaust filter temperatures are hot enough to allow active cleaning.
12	Engine Preheat Indicator	Illuminates when engine air heater is active. A countdown utilizing the ground speed indicator occurs.
13	Auto Shift (Not used)	Illuminates when the auto-shift mode is active.
14	Foot Pedal Mode (Not used)	Illuminates when foot pedal mode has been activated.
15	Range and Gear	Indicates the operator-selected range and gear.
16	AutoTrac	Illuminates with AutoTrac engaged.
17	ISOBUS Auxiliary Mode (Not used)	Illuminates when ISOBUS auxiliary mode is activated.
18	iTEC Basic (Not used)	Illuminates when iTEC Basic is active.

Display Icon	Icon Name	Icon Description
19	Diesel Exhaust Fluid (DEF) Gauge	Indicates amount of diesel exhaust fluid remaining in the tank.
20	Fuel Level Gauge	Indicates amount of fuel remaining in tank.
21	Coolant Temperature Gauge	Indicates engine coolant temperature. Red area indicates overheat (coolant level too low, dirty radiator, or clogged screen). SHUT OFF engine IMMEDIATELY to prevent damage. If necessary, have your John Deere dealer diagnose machine.
22	Air Brake Pressure Gauge (Not used)	Indicates the amount of air brake pressure in the system.
23	Differential Lock	Illuminates when differential lock is engaged.
24	MFWD	Illuminates when mechanical front-wheel drive is engaged.
25	Implement Automation (Not used)	Not used currently.
26	Front PTO	Illuminates when front PTO is engaged.
27	Rear PTO	Illuminates when rear PTO is engaged.
28	Set Speed (Not used)	Indicates the operator-selected target speed.
29	Current Direction, Range, and Gear	Indicates the direction (park, neutral, forward, reverse), range, and gear that are currently active.
30	Creeper	Illuminates when the creeper gears are engaged.
31	Machine Ground Speed	Indicates the actual machine speed.
32	Tachometer	Indicates the actual engine rpm.
33	Brake System Stop	Illuminates when a serious brake system malfunction occurs. Brake system does not perform as expected. Have John Deere dealer diagnose machine immediately.
34	Trailer	Illuminates when one or two trailers are connected and indicator lights are working.
35	Information Display	Allows the operator to observe two pre-determined and three customized pages of machine information.

D3K5H22.00005D8-19-19MAY21

Information Display Navigation Controls

The information display utilizes the buttons and dial on the navigation pad to move through the screens and selections. (See Basic Menu Navigation in this section for more information.)

For more information about specific machine functional systems (hitch, transmission, and so on), see the relevant operational section in this manual.

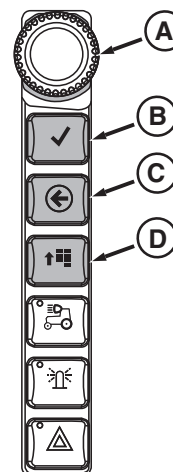

- A—Navigation Dial
- B—Confirm Button
- C—Back Button
- D—Main Menu Button

RXA0180933—UN—18MAY22



Main Menu Button

RXA0152991—UN—21JUL16



Back Button

RXA0152970—UN—21JUL16



Confirm Button

RXA0152979—UN—29JUL16

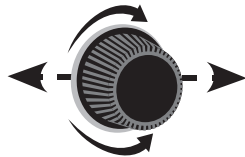

Navigation Dial

RXA0152978—UN—28JUL16

Navigation Dial (A): Rotate the navigation dial to navigate from page to page or through a specific page to change selections. The currently selected choice is highlighted in yellow. As the navigation dial is rotated, the selected choice changes and depending on the screen, allows scrolling left and right or up and down. Rotating the dial in the opposite direction reverses the navigation, allowing the operator to back up if a selection is missed.

Confirm Button (B): Depress the confirm button to make selections or store settings.

Back Button (C): Depress the back button to return to the previous screen.

Main Menu Button (D): Depress the main menu button to navigate from the run pages to other pages or back to the main menu at any time.

D3K5H22,00005CD-19-21APR21

Basic Menu Navigation

This information is a general guide for basic navigation through the various menus and selections of the

information display. Use the following controls on the navigation pad to find and customize the settings within each system. More detailed information about each of the settings is in the operational section for the relevant system.

NOTE: Some menus and selections show up, but prevent access if the feature is not available at that point in time. Other menus do not show up at all if the feature is not installed, which generally requires the purchase of additional software.



Main Menu Button

RXA0152991—UN—21JUL16

1. Depress the main menu button.

NOTE: Information display screens use a yellow highlight where the current selection is or a white arrow where scrolling is possible. White outlined areas are typically items which are available for selection by the operator.

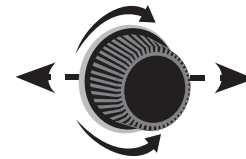

Navigation Dial

RXA0152978—UN—28JUL16



Example (Engine Menu)

RXA0152958—UN—21JUL16

2. Use the navigation dial to locate the relevant or desired system menu:

- Rear Hitch
- SCV
- Transmission
- Engine
- Maintenance
- Diagnostics
- Display Settings
- Layout Manager



Confirm Button

RXA0152979—UN—29JUL16

3. Depress the confirm button to enter the system menu.

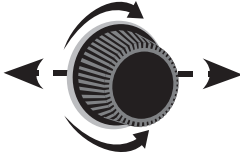

Navigation Dial

RXA0152978—UN—28JUL16



Example (AutoTrac Basic Menu)

RXA0170082—UN—10SEP19

4. Use the navigation dial to select the desired setting.



Confirm Button

RXA0152979—UN—29JUL16

5. Depress the confirm button to enter the setting.

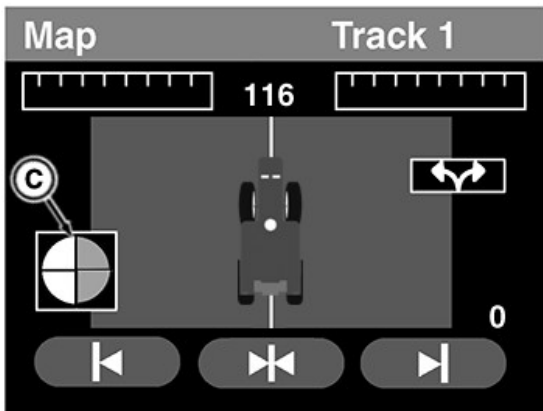

Example (AutoTrac Basic Setting)

RXA0178551—UN—26JUN20

6. Use the navigation dial to change the setting or select a subsetting.



Confirm Button

RXA0152979—UN—29JUL16

7. Depress the confirm button to save changes to the settings.

MP60050,0000B00-19-19MAY21

Run Pages

The run pages will automatically pop up on the information display after boot up if no diagnostic trouble codes or alerts are present. If codes and alerts are present, they must be acknowledged before the run pages appear.

To navigate through the run pages, simply rotate the navigation dial to advance to the next screen.

Run pages allow the operator to observe two pre-determined and three customized pages of machine information. (See Layout Manager Settings in this section for additional information about creating custom run pages.)

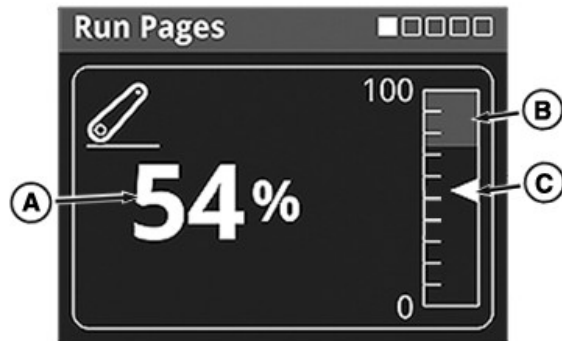

Hitch Run Page

RXA0184700—UN—29JUL21

- A—Hitch Position Actual Value
- B—Upper Limit Indicator
- C—Hitch Position Actual Indicator

The first page to display is the hitch run page and is not configurable. This monitors the upper limit and actual position of the rear hitch.



- A—Run Page Configurable Item 1
- B—Run Page Configurable Item 2

Pages two, three, and four allow the operator to select from many options which information they would like to view.

The fifth page is not configurable and always shows engine hours as the top item and rear PTO speed as the bottom item.

GS25068,0001900-19-02AUG21

Layout Manager Menu

NOTE: For additional navigation information, see Basic Menu Navigation in this section.



RXA0152983—UN—25JUL16
Layout Manager Menu

1. Locate the layout manager menu.



RXA0152993—UN—25JUL16
Run Page 2 Selection



RXA0152994—UN—25JUL16
Run Page 3 Selection



RXA0154363—UN—07DEC16
Run Page 4 Selection

2. Select and change the desired settings as needed. See the relevant topic in this section for additional details on settings.

Selection	Range	Display Response
Run Page 2	Varies	Operator custom run page 2 is configured.
Run Page 3	Varies	Operator custom run page 3 is configured.
Run Page 4	Varies	Operator custom run page 4 is configured.

D3K5H22,00005CE-19-07JUN21

Layout Manager Settings

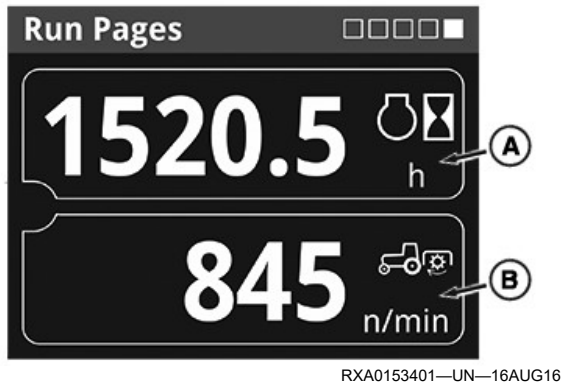

A—Run Page Configurable Item 1
B—Run Page Configurable Item 2

Layout Manager

The layout manager menu allows the operator to customize some of the run pages for quick access to specific information. Each run page is configured with two different values (A and B) using the layout manager.

The first and last run pages in the main menu are fixed and not configurable. When configuring run pages through the layout manager, the actual run page number corresponds to the layout manager page number.

Run page configuration choices are: engine hours, PTO speed, hydraulic oil temperature, coolant temperature, engine oil pressure, and many more. Not all choices are available on all machines, depending on installed options.

GS25068,0005797-19-03OCT18

Display Settings Menu

NOTE: For additional navigation information, see Basic Menu Navigation in this section.

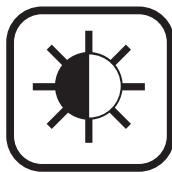

RXA0152984—UN—25JUL16
Display Settings Menu

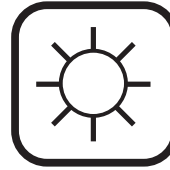

RXA0152985—UN—25JUL16
Brightness Selection

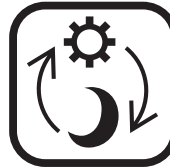

RXA0152986—UN—25JUL16
Display Mode Selection

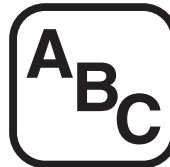

RXA0152987—UN—25JUL16
Language Selection

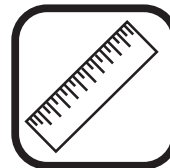

RXA0152988—UN—25JUL16
Units Selection

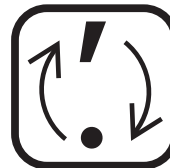

RXA0182564—UN—11MAY21
Numeric Format Selection



RXA0182563—UN—11MAY21
About Selection

1. Locate the display settings menu.
2. Select and change the desired settings as needed. See the relevant topic in this section for additional details on settings.

Selection	Range	Display Response
Brightness	5—100	Higher numbers make display brighter.
Display Mode	Auto, Day, or Night	Auto picks the display mode based on the time of day. Day and night are for the respective time of day.

Selection	Range	Display Response
Language	Available	Operator desired language displays.
Units	Imperial, Metric, or US	Operator desired units display.
Numeric Format	Standard Decimal Notation or Scientific Decimal Notation	Operator desired numeric format display.
About	N/A	Software information.

D3K5H22.00005F7-19-12MAY21

Select units of measure from Imperial, Metric, or US (standard).

Display Settings

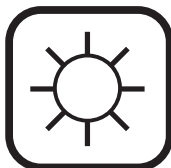

Brightness Icon

RXA0152985—UN—25JUL16

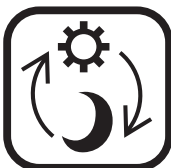

Display Mode Icon

RXA0152986—UN—25JUL16

Brightness and Display Mode:

Adjust the information display brightness and mode that is best suited to the operational conditions. Set the mode to day, night, or auto. Additional fine-tuning of the brightness is required to achieve the best performance.

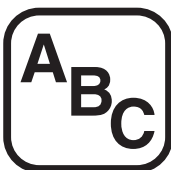

Language Icon

RXA0152987—UN—25JUL16

Language:

Scroll through and change the display language to the desired preference. The text in the informational window is displayed in the chosen language.

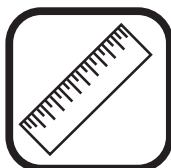

Units Icon

RXA0152988—UN—25JUL16

Units Format:

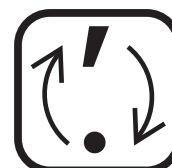

Numeric Format Icon

RXA0182564—UN—11MAY21

Numeric Format:

Select standard decimal notation or scientific decimal notation of numbers.



About Icon

RXA0182563—UN—11MAY21

About Icon:

Displays current software number, software version, and hardware number.

MP60050,0000B1F-19-21MAY21

Work Monitor Menu

NOTE: For additional navigation information, see Basic Menu Navigation in this section.



Work Monitor Menu

RXA0152967—UN—21JUL16

1. Locate the work monitor menu.
2. Select and view available readings.

D3K5H22.00005FC-19-12MAY21

Work Monitor Operation

Readings:

Readings are real-time values the operator can view to understand machine performance during operation. Engine hours, front/rear PTO speed, hydraulic oil temperature, engine coolant temperature, engine oil pressure, and system voltage are shown in readings. The operator cannot manually change any of the readings values.

D3K5H22.00005FB-19-12MAY21

1. Locate the maintenance menu.

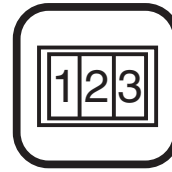

RXA0152974—UN—21JUL16
Service Counter Selection

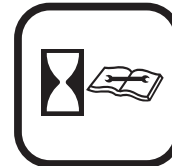

RXA0152975—UN—01AUG16
Service Interval Selection

2. Select and change the desired settings as needed. See the relevant topic in this section for additional details on settings.

Maintenance Menu

NOTE: For additional navigation information, see *Basic Menu Navigation* in this section.



RXA0152973—UN—21JUL16
Maintenance Menu

Selection	Range	Display Response
Service Counter	All values are read only. A reset can be performed by holding the confirm button for 3 s.	Display shows service interval and elapsed time since last reset.
Service Interval	0—990 h	Changes the desired hour interval for the service counter.

D3K5H22.00005D1-19-21APR21

Maintenance Counters and Intervals



RXA0152975—UN—01AUG16
Service Interval Icon



RXA0152974—UN—21JUL16
Service Counter Icon

Service Intervals:

To remind the operator when the next machine service is due, set service interval to next required hour interval. The service interval is changed in the maintenance menu.

20 hours before the service interval is due, the system informs the operator that the machine needs service soon. Once the message has been acknowledged, the system informs the operator about the upcoming service at every start-up until service interval is reset.

Service Counter:

Service interval is displayed with the elapsed time since the last reset. When service is completed, the counter is reset by depressing the confirm button for 3 seconds.

D3K5H22.00005D2-19-21APR21

Drivetrain Operation

Drivetrain Information

The drivetrain information is broken up into different functional systems for operation and maintenance. See the following sections within this manual for detailed information:

Operational Sections

- Transmission Operation
- MFWD and Front Axle Operation
- Differential and Rear Axle Operation
- Power Take-Off (PTO) Operation

Maintenance Sections

- Transmission Maintenance
- MFWD and Front Axle Maintenance
- Differential and Rear Axle Maintenance
- Power Take-Off (PTO) Maintenance

GS25068,00053B6-19-19SEP18

Off Level Operation

IMPORTANT: For any off level operation, engine and hydraulic oil levels must be maintained at the FULL mark to avoid machine damage.

For information on checking oil levels, see Engine Maintenance and Hydraulics Maintenance sections.

IMPORTANT: Machine performance decreases and damage occurs with continuous off level operation in excess of the following recommendations.

Stationary Operation (at full power)

- Continuous operation up to + / - 25° angle.

Mobile Operation (transmitting any combination of, or full transmission, hydraulic, or PTO power)

- Continuous operation up to + / - 20° angle.
- Intermittent operation for 15 minute periods up to +/- 25° angle, but not to exceed 50% of total operating time.
- Intermittent operation for 30 second periods up to +/- 30° angle.

GS25068,0000A98-19-08NOV19

Transmission Operation

Transmission Menu

NOTE: For additional navigation information, see Basic Menu Navigation in the Displays, Software, and Electronics Operation section.



RXA0152949—UN—21JUL16

Transmission Menu



RXA0152953—UN—21JUL16

Rev/Fwd Ratio Selection

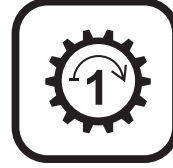

RXA0152955—UN—21JUL16

Start Gears Selection

1. Select the transmission menu.



RXA0152950—UN—21JUL16

PowrReverser Selection

2. Select and change the desired settings as needed. See the relevant topic in this section for additional details on settings.

Selection	Range	Transmission Response
PowrReverser	1—10	Higher values make direction changes more aggressive and quicker.
Rev/Fwd Ratio	Fwd x 0.2—Fwd x 1.067	Sets the forward-to-reverse speed ratio.
Start Gears	A, B, and C Start Gears	Sets the desired start gear for A, B, and C range selection.

MP60050,0000AF9-19-17APR23

Reverse/Forward Ratio



RXA0152953—UN—21JUL16

Rev/Fwd Ratio Icon

Transmission Settings

PowrReverser



RXA0152950—UN—21JUL16

PowrReverser Icon

PowrReverser modulation sets aggressiveness of change in direction. Modulation can be set between 1 and 10.

Setting “1” is the least aggressive and is used in applications where precise control and smooth direction changes are required. Setting “10” is the most aggressive and is used in high-productivity applications where quick direction changes are required.

Independently programmable reverse/forward ratio allows the operator to control the forward speed as a ratio of the reverse speed.

Reverse ratio is adjustable up to 100% faster or up to 80% slower than the forward speed in 20% increments. Example: If forward speed is 10 km/h (6.2 mph) and ratio is set at 1.0, then reverse speed defaults as close to 10 km/h (6.2 mph) as possible.

Independent selection remembers the last forward and reverse gear setting. Once the gear is manually changed in the reverse direction, the gear automatically returns to the last gear when changing directions. If the gear is not manually changed when in reverse direction, then the forward and reverse gears remain the same when changing directions.

Start Gears



Start Gears Icon

RXA0152955—UN—21JUL16

Start gears are selectable by the operator.

- A, B, or C Range: Any gear between 1 and 4 or 1 and 8 (depending on transmission configuration) can be selected.

Example: If 4 is selected as the start gear for A range, any time the range shift lever is shifted into A range, the transmission defaults to gear 4. The operator can shift to any gear from there, but the starting point is what the operator has programmed. Within any range, the preset start gears are the highest gears within the range. Start gears are not adjustable by the operator.

MP60050,0000AFA-19-17MAY21

- **Creeper Indicator (C):** Illuminates when the creeper lever has been shifted into low or high range.
- **Direction, Range, and Gear Indicator (D):** Displays current direction, range, and gear the transmission is in.

- **P** — Park
- **N** — Neutral
- **F D2** — Forward D2 Gear
- **R A3** — Reverse A3 Gear

MP60050,0000AC9-19-27APR21

16/16 Speed PowrQuad PLUS Transmission

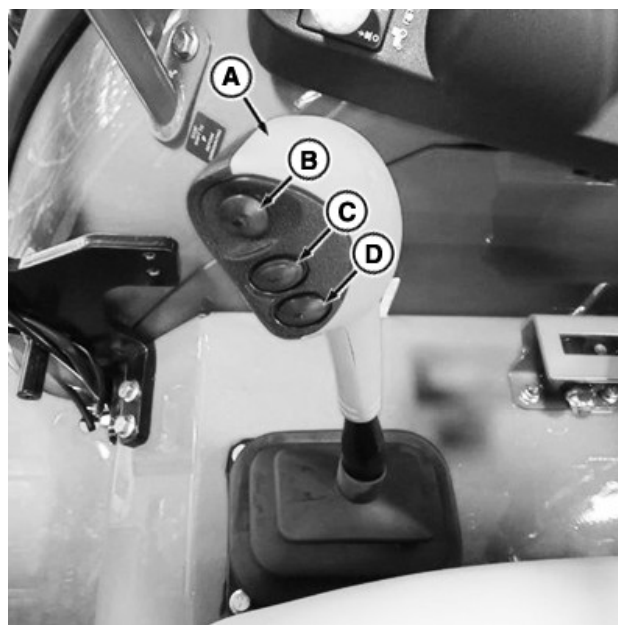

Range Shift Lever

RXA0161661—UN—09JAN18

Transmission Indicators

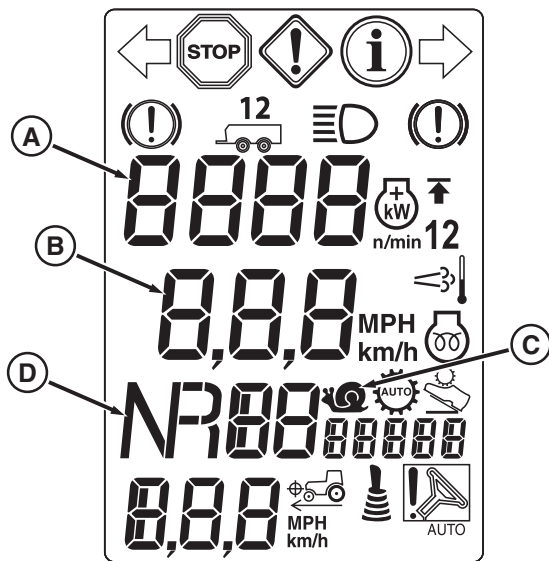

RXA0182444—UN—20APR21

- A—Tachometer
- B—Ground Speed
- C—Creeper Indicator
- D—Direction, Range, and Gear Indicator

- **Tachometer (A):** Displays current engine speed in revolutions per minute.
- **Ground Speed (B):** Displays the actual current machine speed in either kilometers per hour or miles per hour.



Right-Hand Console Speed Shift Switch

RXA0181043—UN—05FEB21

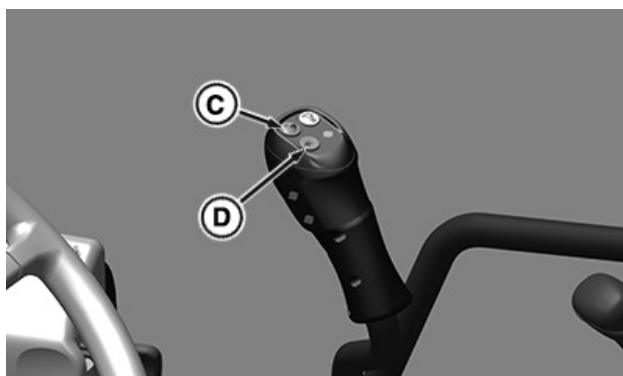

RXA0181044—UN—05FEB21

Mid-Mount SCV Joystick Speed Shift Buttons



RXA0161662—UN—09JAN18

Left-Hand Reverser Lever

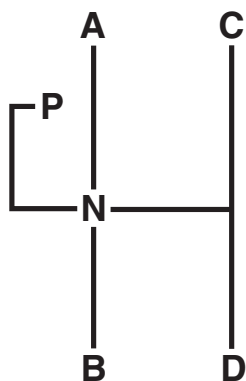

RXA0183477—UN—16JUN21

Range Shift Pattern

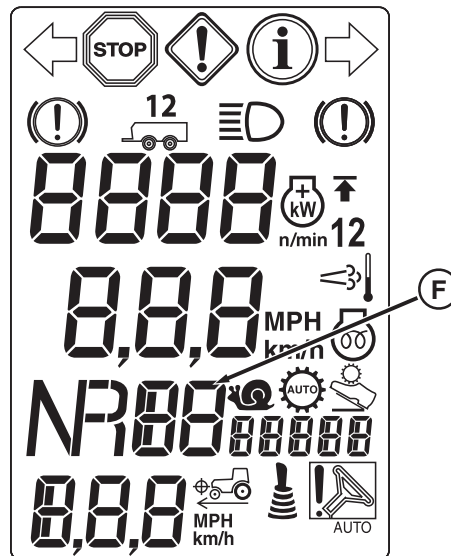

RXA0182557—UN—20APR21

Direction, Range, and Gear Indicator

- A—Range Shift Lever
- B—Declutch Button
- C—Speed Shift Up
- D—Speed Shift Down
- E—Left-Hand Reverser Lever
- F—Direction, Range, and Gear Indicator

CAUTION: Avoid unintended machine movement. Put range shift lever (A) in Park, left-hand reverser lever (E) in Neutral, and shut machine off before dismounting.

Range shift lever (A) provides four forward and reverse ranges: A, B, C, and D. Declutch button (B) can be used instead of the clutch pedal. There are 16 forward and reverse speeds available.

Left-hand reverser lever (E) provides travel direction (forward or reverse).

NOTE: If either of the following conditions are present, starting is not possible:

- Range shift lever (A) is in a position other than Neutral or Park.
- Left-hand reverser lever (E) is not in Neutral.

Depress clutch pedal or declutch button (B) when shifting between ranges. The gears are synchronized, allowing on-the-go shifting into those ranges.

Use the speed shift up (C) and speed shift down (D) buttons on the range shift lever, right-hand console switch, or mid-mount SCV joystick to upshift and downshift gears within the selected range.

D3K5H22.00005EA-19-16JUN21

32/16 Speed Powr8 Transmission

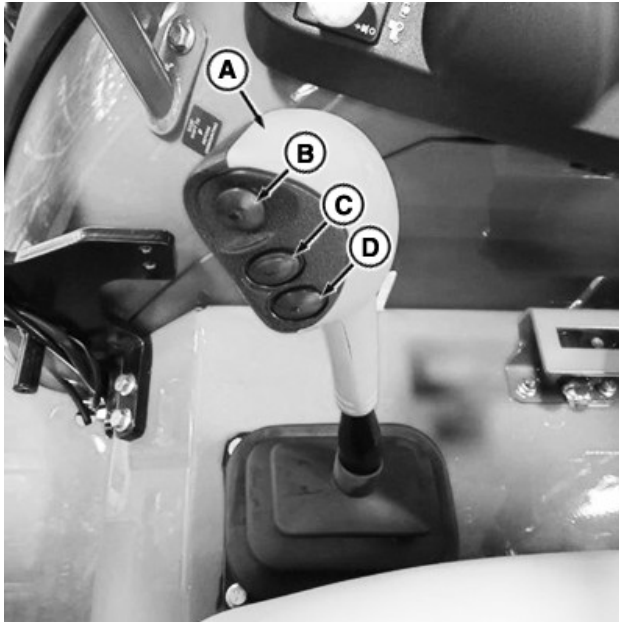

Range Shift Lever

RXA0161661—UN—09JAN18



Left-Hand Reverser Lever

RXA0161662—UN—09JAN18

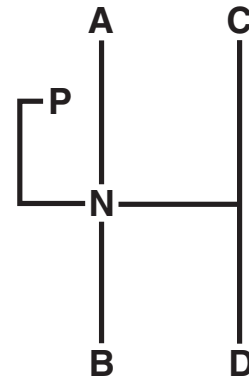

Range Shift Pattern

RXA0183477—UN—16JUN21

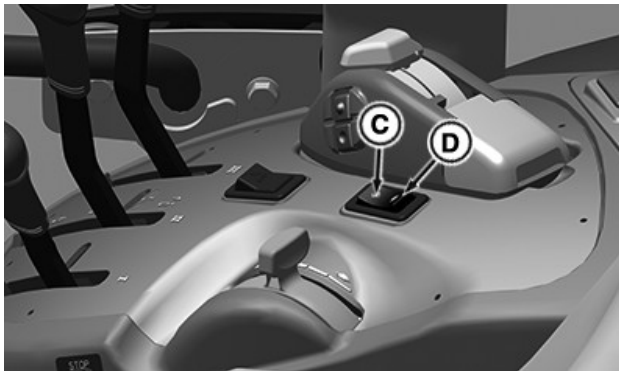

Right-Hand Console Speed Shift Switch

RXA0181043—UN—05FEB21

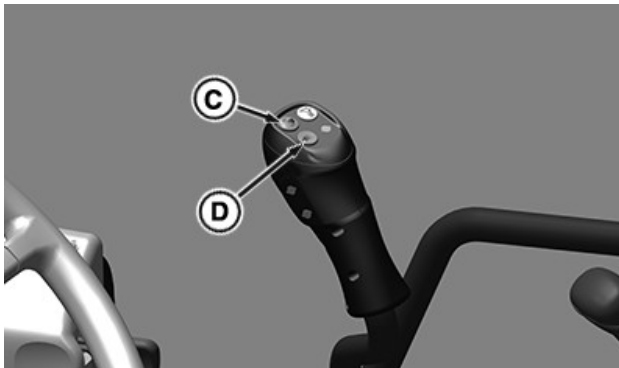

Mid-Mount SCV Joystick Speed Shift Buttons

RXA0181044—UN—05FEB21

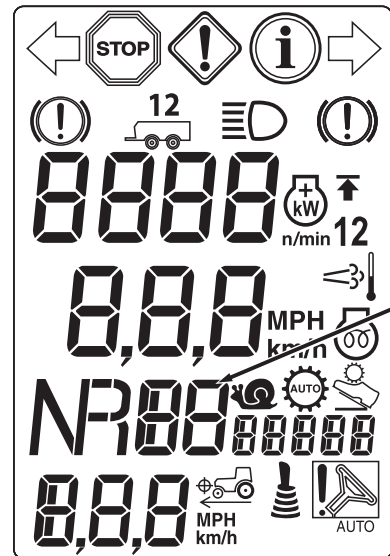

Direction, Range, and Gear Indicator

RXA0182557—UN—20APR21

- A—Range Shift Lever
- B—Declutch Button
- C—Speed Shift Up
- D—Speed Shift Down
- E—Left-Hand Reverser Lever
- F—Direction, Range, and Gear Indicator

CAUTION: Avoid unintended machine movement. Put range shift lever (A) in Park, left-hand reverser lever (E) in Neutral, and shut machine off before dismounting.

Range shift lever (A) provides four forward and reverse ranges: A, B, C, and D. Declutch button (B) can be used instead of the clutch pedal. 32 forward and 16 reverse speeds are available due to a high/low clutch which splits each forward gear.

Left-hand reverser lever (E) provides travel direction (forward or reverse).

NOTE: If either of the following conditions are present, starting is not possible:

- Range shift lever (A) is in a position other than Neutral or Park.
- Left-hand reverser lever (E) is not in Neutral.

Depress clutch pedal or declutch button (B) when shifting between ranges. The gears are synchronized, allowing on-the-go shifting into those ranges.

Use the speed shift up (C) and speed shift down (D) buttons on the range shift lever, right-hand console switch, or mid-mount SCV joystick to upshift and downshift gears within the selected range.

NOTE: Slow speed gearing (creeper) is controlled by a dedicated lever. Range shift lever must be in neutral position to shift into creeper.

D3K5H22,00005EB-19-16JUN21

- B—Creeper High Range
- C—Creeper Disengaged
- D—Creeper Low Range

IMPORTANT: Do not use creeper transmission when working with implements that penetrate the soil and require high traction force.

The creeper is a set of low gears that allows operations below 2.50 km/h (1.55 mph). To find the best gear for an application, see 32/16 Speed Transmission Creeper Ground Speed Chart in this section.

To engage the creeper:

1. Move machine to a level location.
2. Apply brakes to prevent machine motion.
3. Place the left-hand reverser lever in Neutral.
4. Place the range shift lever in neutral.

NOTE: Range shift lever must remain in neutral to operate creeper.

5. Move creeper shift lever (A) to the left and out of the detent position.
6. Move lever forward for creeper high range (B) or rearward for creeper low range (D).
7. Creeper indicator illuminates on primary display. See Transmission Indicators in this section.
8. Creeper is operated with the speed shift buttons and left-hand reverser, similar to normal transmission function.
9. To disengage, repeat procedure and place lever in the creeper disengaged position (C).

MP60050,0000AC4-19-27MAR23

Creeper Gear Operation

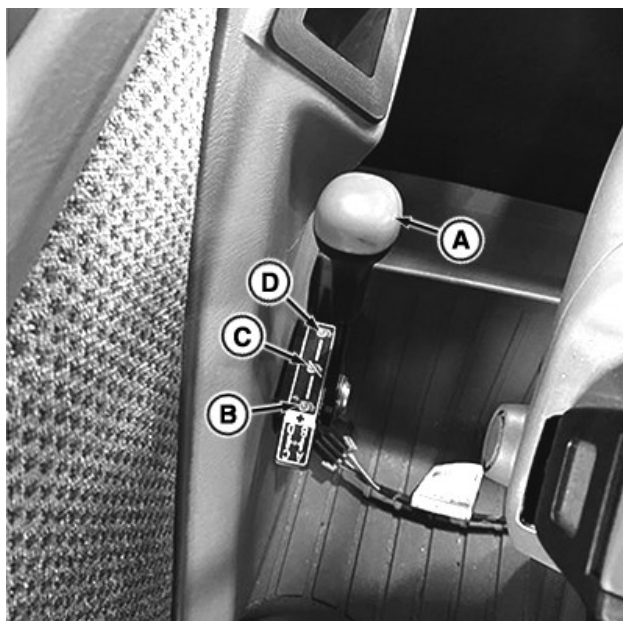

RXA0181058—UN—11MAR21

A—Creeper Shift Lever

Downhill Operation in Slippery Conditions

CAUTION: Avoid possible injury from losing control of machine while operating on a downhill slope. Wheels can lock and skid on slippery downhill slopes. Observe the following precautions:

- Reduce machine speed.
- Select an appropriate gear and range to reduce skidding.
- Set MFWD to On.

MP60050,00009F0-19-11FEB21

16/16 Speed Transmission Ground Speed Chart

Ground speeds are calculated using 19.5L-24

Transmission Operation

Goodyear rear tires at 2200 rpm engine speed. To calculate ground speeds for machines equipped with rear tires other than 19.5L-24 Goodyear tires, see Correction Factors for Other Tire Sizes in this section.

NOTE: Ground speeds are limited to 40 km/h (25 mph) in forward and 30 km/h (19 mph) in reverse.

Forward Gear	Forward km/h (mph)	Reverse Gear	Reverse km/h (mph)
A1	1.84 (1.14)	A1	1.97 (1.22)
A2	2.27 (1.41)	A2	2.43 (1.51)
A3	2.82 (1.75)	A3	3.01 (1.87)
A4	3.46 (2.15)	A4	3.69 (2.29)
B1	4.26 (2.65)	B1	4.55 (2.83)
B2	5.26 (3.27)	B2	5.62 (3.49)
B3	6.52 (4.05)	B3	6.96 (4.32)
B4	8.00 (4.97)	B4	8.54 (5.31)
C1	8.25 (5.13)	C1	8.81 (5.47)
C2	10.19 (6.33)	C2	10.87 (6.76)
C3	12.62 (7.84)	C3	13.47 (8.37)
C4	15.49 (9.62)	C4	16.53 (10.27)
D1	18.47 (11.48)	D1	19.71 (12.25)
D2	22.81 (14.17)	D2	24.34 (15.13)
D3	28.26 (17.56)	D3	30.16 (18.74)
D4	32.89 (20.44)	D4	37.01 (23.00)

MP60050,0000B1B-19-19MAY21

32/16 Speed Transmission Ground Speed Chart

Ground speeds are calculated using 19.5L-24 Goodyear rear tires at 2200 rpm engine speed. To calculate ground speeds for machines equipped with

rear tires other than 19.5L-24 Goodyear tires, see Correction Factors for Other Tire Sizes in this section.

NOTE: Ground speeds are limited to 40 km/h (25 mph) in forward and 30 km/h (19 mph) in reverse.

Forward Gear	Forward km/h (mph)	Reverse Gear	Reverse km/h (mph)
A1	1.84 (1.14)	A1	1.97 (1.22)
A2	2.07 (1.29)	A2	2.43 (1.51)
A3	2.27 (1.41)		
A4	2.56 (1.59)		
A5	2.82 (1.75)	A3	3.01 (1.87)
A6	3.17 (1.97)	A4	3.69 (2.29)
A7	3.46 (2.15)		
A8	3.89 (2.41)	B1	4.55 (2.83)
B1	4.26 (2.65)		
B2	4.79 (2.98)		
B3	5.26 (3.27)		
B4	5.92 (3.68)		
B5	6.52 (4.05)	B2	5.62 (3.49)
B6	7.33 (4.55)	B3	6.96 (4.32)
B7	8.00 (4.97)		
B8	9.00 (5.59)	B4	8.54 (5.31)
C1	8.25 (5.13)	C1	8.81 (5.47)
C2	9.27 (5.76)		
C3	10.19 (6.33)	C2	10.87 (6.76)
C4	11.45 (7.12)		
C5	12.62 (7.84)		
		C3	13.47 (8.37)

Transmission Operation

Forward Gear	Forward km/h (mph)	Reverse Gear	Reverse km/h (mph)
C6	14.19 (8.82)		
C7	15.49 (9.62)	C4	16.53 (10.27)
C8	17.41 (10.82)		
D1	18.47 (11.48)	D1	19.71 (12.25)
D2	20.76 (12.90)	D2	24.34 (15.13)
D3	22.81 (14.17)		
D4	25.64 (15.93)		
D5	28.26 (17.56)	D3	30.16 (18.74)
D6	31.76 (19.74)	D4	37.01 (23.00)
D7	34.70 (21.56)		
D8	39.00 (24.23)		

MP60050,0000B1C-19-19MAY21

32/16 Speed Transmission Creeper Ground Speed Chart

Ground speeds are calculated using 19.5L-24 Goodyear rear tires at 2200 rpm engine speed. To

calculate ground speeds for machines equipped with rear tires other than 19.5L-24 Goodyear tires, see Correction Factors for Other Tire Sizes in this section.

Forward Gear	Forward km/h (mph)	Reverse Gear	Reverse km/h (mph)
Creeper Low 1	0.35 (0.22)	Creeper Low 1	0.38 (0.23)
Creeper Low 2	0.40 (0.25)		
Creeper Low 3	0.44 (0.27)	Creeper Low 2	0.47 (0.29)
Creeper Low 4	0.49 (0.30)		
Creeper Low 5	0.54 (0.33)	Creeper Low 3	0.58 (0.36)
Creeper Low 6	0.61 (0.38)		
Creeper Low 7	0.66 (0.41)	Creeper Low 4	0.71 (0.44)
Creeper Low 8	0.75 (0.47)		
Creeper High 1	0.88 (0.55)	Creeper High 1	0.94 (0.58)
Creeper High 2	0.99 (0.62)		
Creeper High 3	1.09 (0.68)	Creeper High 2	1.16 (0.72)
Creeper High 4	1.23 (0.76)		
Creeper High 5	1.35 (0.84)	Creeper High 3	1.44 (0.89)
Creeper High 6	1.52 (0.95)		
Creeper High 7	1.66 (1.00)	Creeper High 4	1.77 (1.10)
Creeper High 8	1.86 (1.15)		

MP60050,0000B1D-19-24JUN21

Correction Factors for Other Tire Sizes

NOTE: Actual speed varies due to a number of factors. Factors include (but are not limited to) rolling circumference, load, tire pressure, tire manufacturer, and wheel slip. If the precise speed is required for specific applications, then measurement is necessary.

The following table is used to calculate ground speeds for machines equipped with rear tires other than 19.5L-

24 Goodyear tires. Multiply speeds shown in the relevant ground speed charts in this section by the correction factor for the appropriate tire size found in the table.

Be sure to use correct ground speed estimate for transmission type (16/16 or 32/16 speed transmission). Use creeper transmission ground speed estimates as required.

Example: Forward B-3 (16/16 Speed Transmission) at 2200 engine rpm with 16.9R30 (420/85R30) tires.

6.52 (4.05) x 1.11 = 7.2 km/h (4.5 mph)

Tire Size	Correction Factor
19.5L-24 In	1.00
16.9R30 (420/85R30)	1.14
18.4R30 (460/85R30)	1.18
480/70R34	1.20
400/75R38	1.21
480/80R34	1.27
18.4R34 (460/85R34)	1.27
540/65R38	1.28
16.9R38 (420/85R38)	1.29
230/95R48	1.30

MP60050.0000B1E-19-26JUL21

MFWD and Front Axle Operation

Mechanical Front-Wheel Drive (MFWD On/ Auto/Brake Assist)



LV9489—UN—13AUG04

A—MFWD Switch
B—MFWD Indicator

⚠ CAUTION: Use extra caution on slopes. MFWD use greatly increases traction but does not increase the machines stability.

IMPORTANT: If the machine is under full load and mired down, engaging MFWD while tires are spinning can cause damage. Reduce the load and slow wheel speed before engaging MFWD.

MFWD can be engaged and disengaged in all gears (forward and reverse) during operation and under full load. MFWD switch (A) has three operating positions.

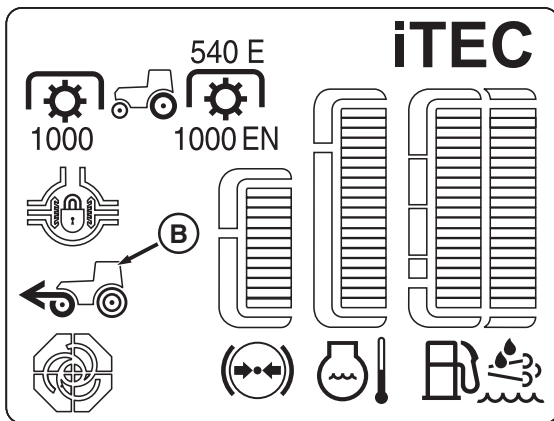

RXA0181045—UN—27APR21

MFWD Selection	MFWD Switch Position	MFWD On	MFWD Off	MFWD Indicator	Recommended for:
AUTO	Top half of switch pressed down.	<ul style="list-style-type: none"> Both brake pedals are depressed at any speed. Speed is below 19 km/h (11.8 mph). Neither brake pedal is individually depressed. 	<ul style="list-style-type: none"> Either brake pedal is individually depressed. Speed is above 23 km/h (14 mph). 	Illuminates when MFWD On conditions are met.	Transport where MFWD is needed.
On	Switch in center position.	Always.	Never.	Always illuminated.	Field use only at speeds below 23 km/h (14.3 mph).
Brake Assist	Bottom half of switch pressed down.	Speed above 5 km/h (3.1 mph) and both brake pedals are depressed.	Always, unless both brake pedals are depressed above 5 km/h (3.1 mph).	Illuminates when MFWD On conditions are met.	Normal transport where MFWD is not needed.

Differential and Rear Axle Operation

Differential Lock

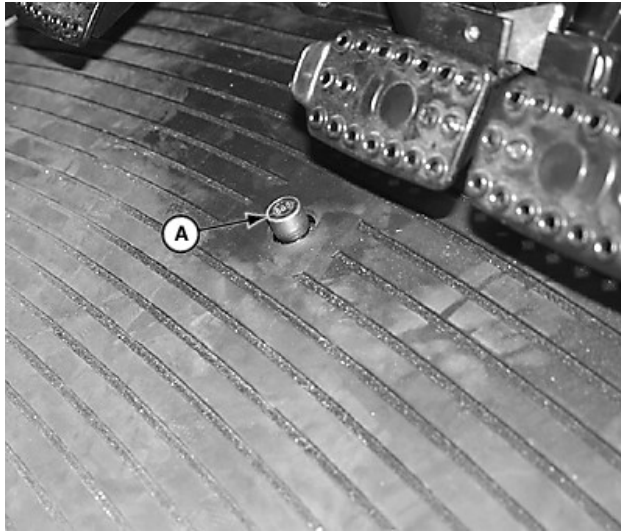

LV14556—UN—03AUG11

Unequal traction keeps the lock engaged. When traction equalizes, lock disengages itself by spring action. If lock does not disengage, depress one brake pedal and then the other.

If tires repeatedly slip, then get traction, then slip again, hold switch down to constantly engage differential lock.

MP60050,00009DE-19-10FEB21

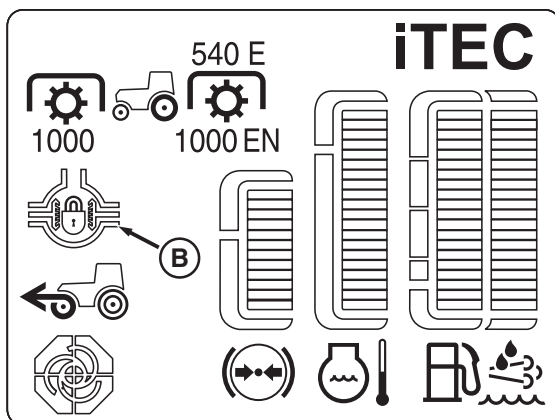

RXA0181046—UN—27APR21

A—Differential Lock Switch
B—Differential Lock Indicator

CAUTION: Do not operate the machine at high speed or attempt to turn with differential lock engaged. Damage to machine can occur.

IMPORTANT: Engage differential lock before entering a situation where wheel slippage occurs or when all wheels appear to be turning at the same speed. Engaging differential lock after wheels begin to spin at different speeds can result in differential damage.

When one rear wheel starts to lose traction, depress and hold switch (A) to engage differential lock. Differential lock indicator (B) illuminates on primary display when differential lock is engaged.

Power Take-Off (PTO) Operation

Match Machine Power to Implement

IMPORTANT: Matching machine and implement ensures that damage to either does not occur.

Overpowering an implement causes damage. Attaching an implement that requires more horsepower than the machine can produce causes damage to the machine.

Refer to your implement operator's manual for minimum and maximum power requirements before attaching to machine.

DP51502,0002A58-19-02FEB17

PTO Guard

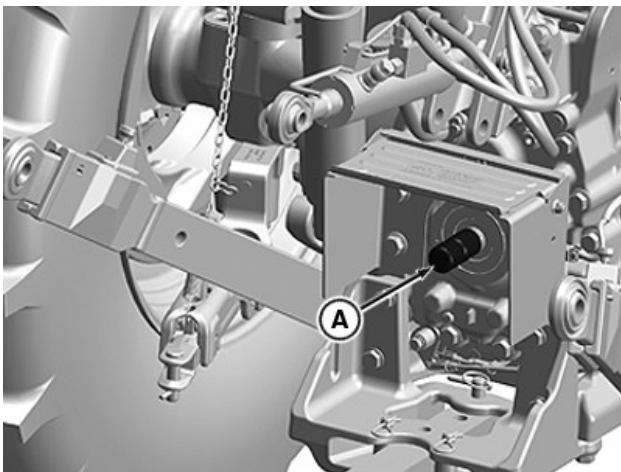

A—PTO Guard

PY39989—UN—09MAY17

CAUTION: Keep PTO guard in place when a PTO implement is not attached.

Ensure that PTO is OFF and has come to a complete stop before attaching or detaching implements.

Remove guard when attaching a PTO-driven implement. After PTO driven implement is unattached, replace PTO guard.

MP60050,00009FA-19-10AUG22

PTO Shield

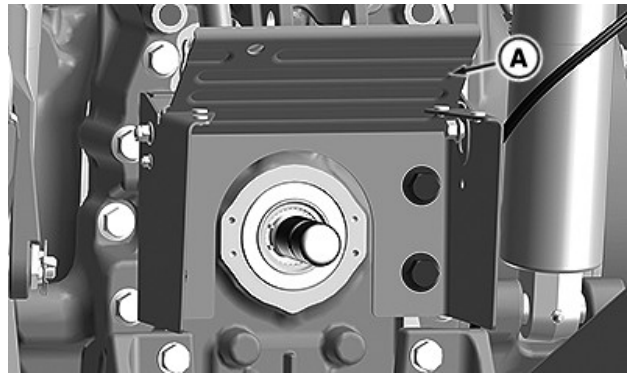

RXA0181090—UN—05MAY21

A—Flip-Up PTO Shield
B—Front PTO Shield

CAUTION: Avoid injury, do not remove the PTO shield or use as a step.

Flip-up PTO shield (A) allows the top to be moved up to allow more room to connect implements. Once the implement is connected, the top must be pushed down parallel to PTO shaft before engaging PTO to provide proper protection.

Front PTO shield (B) is a fixed shield and does not open up.

MP60050,0000ACF-19-10AUG22

PTO Drive Shaft Shield



TS1644—UN—22AUG95

CAUTION: Entanglement in the PTO driveshaft causes serious injury or death. Use proper shield and guards in good working order at all times when operating PTO-driven implements.

PTO driveshaft shields must be in good working order and completely cover the PTO shaft when installed and during use. PTO driveshaft shield must not rotate with the shaft.

Before connecting, cleaning, or adjusting PTO or PTO-driven equipment, do the following:

1. Turn the PTO OFF.

2. Wait for PTO shaft and PTO-driven equipment to come to a complete stop.
3. Turn the engine OFF.
4. Remove key.

MP60050,00009FB-19-15FEB21

Select PTO Drawbar Position

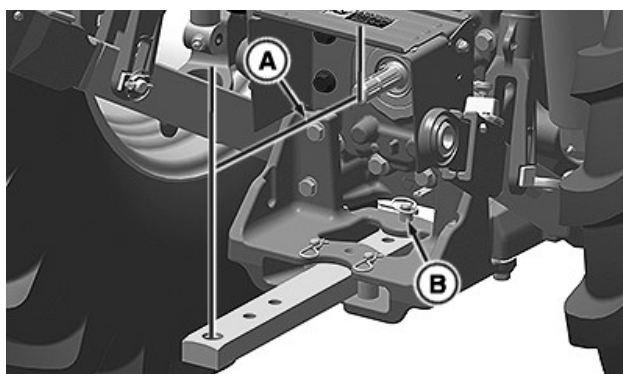

RXA0153739—UN—06SEP16

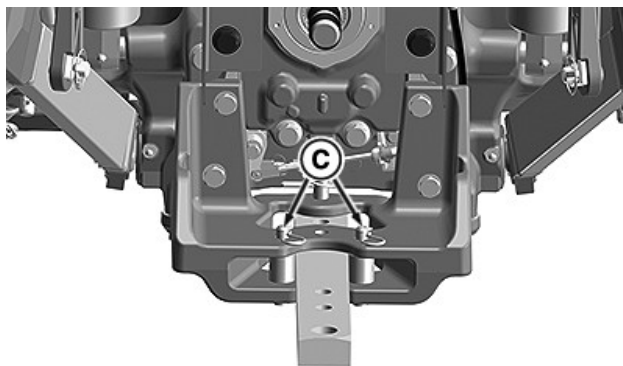

RXA0153744—UN—07SEP16

Drawbar Alignment Pins

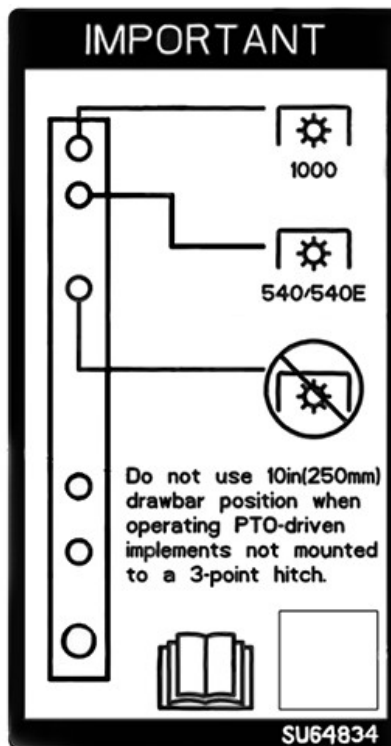

APY78935—19—30JAN23

- A—PTO Shaft End to Hitch Pin Hole
- B—Drawbar Adjustment Pin
- C—Drawbar Alignment Pins

CAUTION: Ensure that PTO is OFF, has come to a complete stop, and allowed too cool before attaching or detaching implements.

IMPORTANT: Do not use 10in (250 mm) drawbar position when operating PTO-driven implements not mounted to a 3-point hitch.

1. Measure PTO shaft end to the hitch pin hole (A) and adjust for the application as required.
2. Remove drawbar adjustment pin (B), set drawbar length, and replace pin.
3. Set drawbar to center position (no offset) and install alignment pins (C) to prevent drawbar movement.

PTO Type	PTO Shaft End to Hitch Pin Hole
540 and 540E (6-spline) or 1000 (21-spline)	250 mm (9.84 in)
Not Used with 3-Point Hitch-Mounted PTO-Driven Implements	350 mm (13.78 in) or 400 mm (15.75 in)

3-Point Hitch-Mounted PTO-Driven Implement Drawbar Position

PTO Type	PTO Shaft End to Hitch Pin Hole
Not Used with Pull-Type PTO-Driven Implements	250 mm (9.84 in)
540 and 540E (6-spline)	350 mm (13.78 in)

Power Take-Off (PTO) Operation

PTO Type	PTO Shaft End to Hitch Pin Hole
1000 (21-spline)	400 mm (15.75 in)

Pull-Type PTO-Driven Implement Drawbar Position

MP60050,00009FC-19-07FEB23

Exchangeable 540/1000¹ rpm PTO Shaft

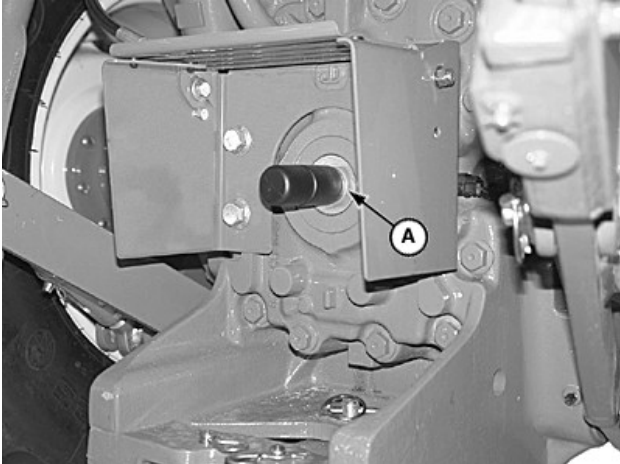

LV14632—UN—11AUG11

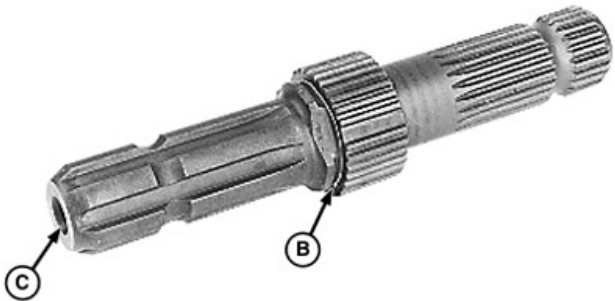

LV12604—UN—26APR05

A—Snap Ring
B—PTO Shaft
C—Bore

CAUTION: Ensure that PTO is OFF, has come to a complete stop, and allowed too cool before attaching or detaching implements.

IMPORTANT: Make sure to select either 540 rpm or 1000¹ rpm mode after changing PTO shaft. In 1000¹ rpm mode, PTO shaft will rotate at same speed in all lever positions. (See Select Correct PTO Speeds in this section.)

NOTE: When exchanging the PTO shaft, hydraulic oil does not leak out due to a dry socket design.

PTO stub shaft has six splines for operating 540 rpm implements and 21 splines for 1000¹ rpm implements.

¹ if equipped

1. Locate flattened area on the stub shaft which facilitates snap ring removal and installation.
2. Align snap ring ends with flattened area. Remove snap ring (A) and pull out PTO shaft (B).
3. Clean PTO shaft thoroughly and lightly coat with grease. Be sure the end bore (C) is clean if installing shaft for 1000¹ rpm operation.
4. Turn PTO shaft end-for-end and insert in the PTO housing until snap ring groove is visible.
 - a. **540 rpm shaft**—Rotate the shaft back and forth while installing. Ensure that the shaft is properly seated in housing; continue to push shaft in when installing snap ring.
 - b. **1000¹ rpm shaft**—Rotate the shaft back and forth while installing until engagement is felt.
5. Install snap ring in the groove to retain PTO stub shaft. Align ends of the snap ring with flat surface of shaft.

GS25068,00053C7-19-23MAY23

Attach PTO-Driven Implement

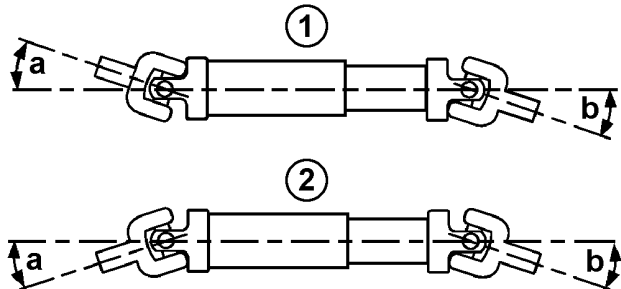

LX1049749

LX1049749—UN—21MAY10

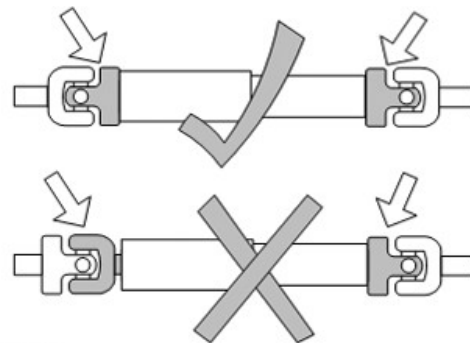

LX1049900

LX1049900—UN—22FEB11

1—Z-Shaped Layout
2—W-Shaped Layout

CAUTION: Ensure that PTO is OFF, has come to a complete stop, and allowed too cool before attaching or detaching implements.

The drawings do not show guards on the driveshaft for illustration purposes. A guard is mandatory when using driveshafts.

IMPORTANT: On telescopic driveshafts, the yokes at each end must be aligned as shown. The yokes at each end must not be at 90° to one another.

Angles (a) and (b) at the universal joints must be nearly the same at both ends of the driveshaft. In applications where it is not possible (sharp turns with PTO engaged), it is recommended to use a continuous-velocity driveshaft.

1. Turn the PTO OFF.
2. Turn the engine OFF and remove key.
3. Set drawbar for the application. (See Select PTO Drawbar Position in this section.)
4. Raise PTO shield (if equipped with flip-up style) and remove PTO guard.
5. Attach implement to the machine (drawbar or 3-point hitch) before connecting PTO. Raise hitch to full height (transport) position if it is not to be used.
6. With engine off, turn PTO driveshaft by hand to line up splines. Connect implement driveshaft to PTO shaft until driveshaft lock engages. Pull implement driveshaft to be sure that it is locked to PTO shaft.
7. Lower PTO shield. Check that all shields are in place and in good condition. Check implement driveshaft shields to ensure that they rotate freely on shaft. Lubricate or repair as necessary.

MP60050,00009FD-19-15FEB21

Select Correct PTO Speed



2—Speed PTO

RXA0158302—UN—21MAR17

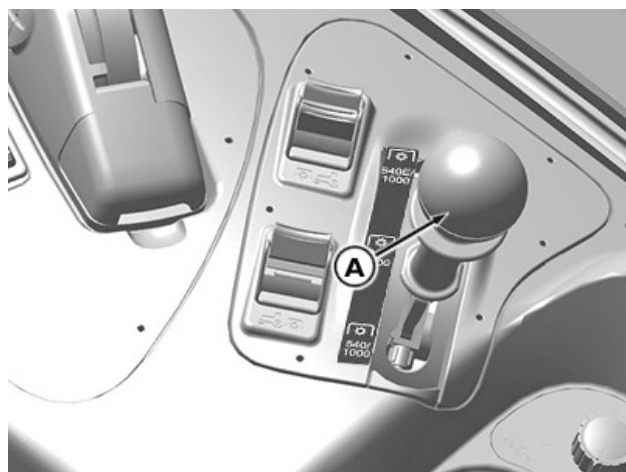

APY84647—UN—31MAY23

Exchangeable PTO (If Equipped)

A—PTO Shift Lever

IMPORTANT: Disengage PTO and allow to come to a complete stop before changing PTO speed with lever (A). NEVER immediately use PTO shift lever (A) to engage or disengage PTO, or damage occurs.

Refer to the implement operator's manual for correct PTO speed and shaft to use for best performance.

1. Adjust drawbar for PTO selection.
2. Change PTO shaft to 540 or 1000² rpm as needed.
3. Attach implement.
4. Move PTO shift lever (A) rearward for 540/1000² rpm standard operation.
5. Move PTO shift lever forward for 540E/1000² operation. Economy mode is designed for lighter PTO loads where power requirements do not require higher engine rpm levels. It helps to conserve fuel and lowers noise levels.

PTO Speed	Recommended Applications
540	Normal to heavy loads requiring full engine power.
1000 ^a	Normal to heavy loads requiring full engine power.
540E _b	Light loads not requiring full engine power.

^aIf Equipped

^bLimited to maximum 1815 rpm.

MP60050,00009DF-19-01JUN23

² If Equipped

Operate Rear PTO

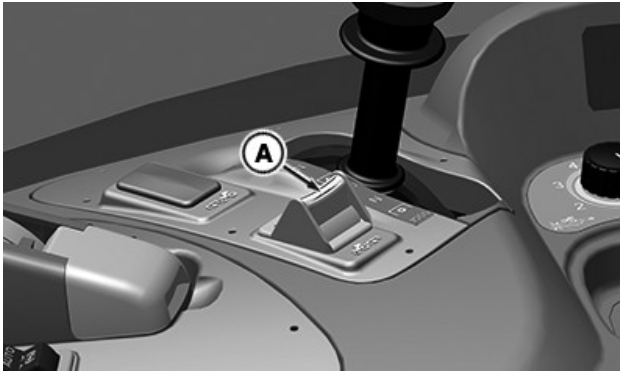

RXA0158304—UN—21MAR17

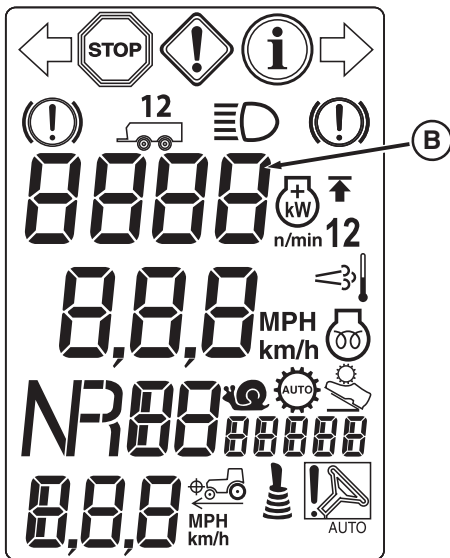

RXA0182558—UN—20APR21

C—Rear PTO Indicator

CAUTION: If PTO engages at engine start-up, contact your John Deere dealer for service.

If PTO is engaged and the remote switch is pressed, PTO disengages regardless of whether remote operation is armed.

NOTE: Engine starts with PTO switch engaged, but PTO switch must be cycled off and on again before PTO engages.

1. Start engine and set to correct speed rating for PTO application. Observe tachometer (B) for engine speed.

Rear PTO	Engine Speed (rpm)
540/1000	2100
540E	1645

NOTE: Operator must be seated when the PTO is engaged. PTO does not engage if the operator is absent.

2. Push down and forward on rear PTO switch (A) to engage rear PTO.
3. Rear PTO indicator (C) and PTO mode illuminate on the display.
4. Pull rear PTO switch (A) to disengage rear PTO.

D3K5H22.00005C9-19-19APR21

Operate Rear Remote PTO



RXA0153741—UN—06SEP16

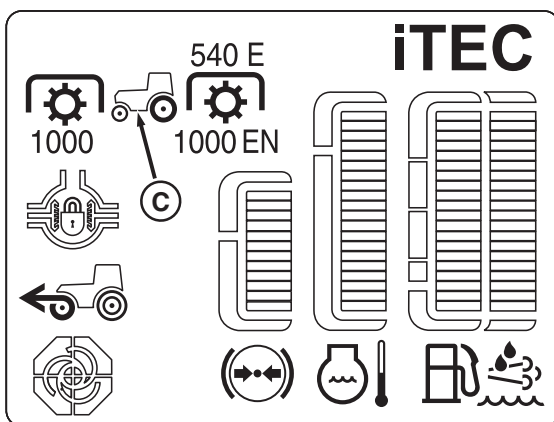

RXA0181048—UN—27APR21

A—Rear PTO Switch
B—Tachometer

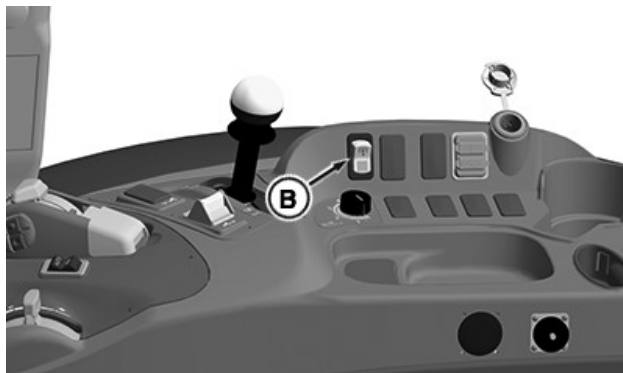

RXA0158330—UN—02MAY17

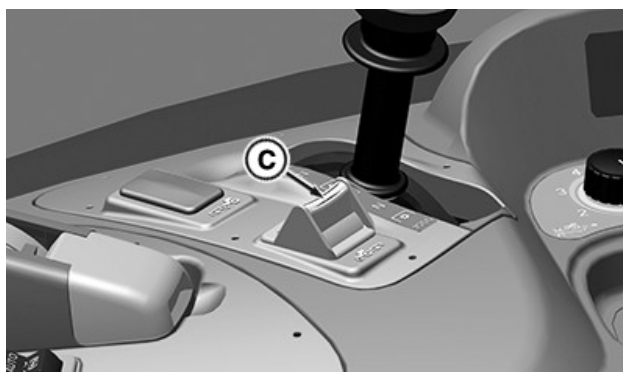

RXA0181049—UN—09FEB21

- A—Rear PTO Fender Switch
- B—Remote PTO Enable Switch
- C—Rear PTO Switch

To operate rear PTO utilizing the rear PTO fender switch (A):

1. Park machine.
2. Depress remote PTO enable switch (B) and an LED indicator in the switch illuminates.
3. Push down and forward on rear PTO switch (C) to arm PTO.
4. An audible warning sounds and hazard warning lights flash to indicate that the rear PTO fender switches are activated. PTO shaft is not moving.
5. Press and hold rear PTO fender switch (A). Rear PTO slowly begins to start.
 - Press and hold switch for at least 4 seconds:
 - Audible warning stops.
 - Warning lights turn off.
 - PTO continues to operate.
 - Release switch within 4 seconds:
 - PTO slowly stops.
 - Audible warning sounds.
 - Warning lights flash.
6. Press rear PTO fender switch (A) again to shut off rear PTO. Rear PTO can also be shut off by pulling rear PTO switch (C) rearward.
7. Rear PTO can be engaged and disengaged using

the fender switch until the operator disengages the PTO using the rear PTO switch (C) or returns to the operator's seat.

MP60050.00009E7-19-11FEB21

Operate Front PTO



PY42025—UN—27APR17

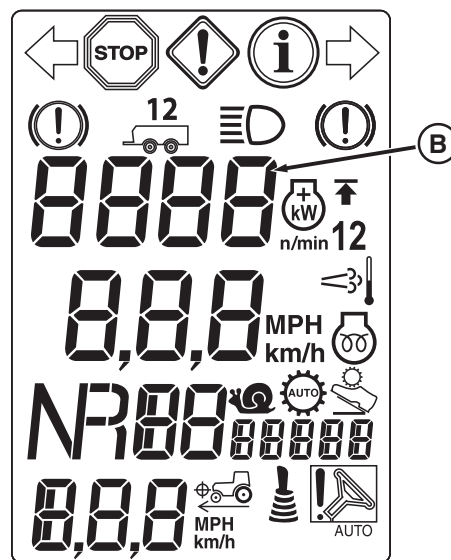

RXA0182558—UN—20APR21

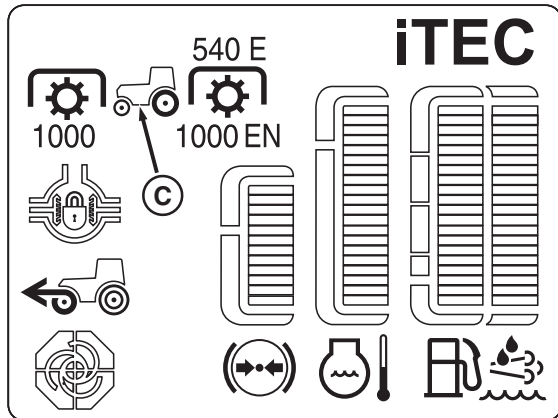

- A—Front PTO Switch
- B—Tachometer
- C—Front PTO Indicator

RXA0181048—UN—27APR21

CAUTION: If PTO engages at engine start-up, contact your John Deere dealer for service.

NOTE: Engine starts with PTO switch engaged, but PTO switch must be cycled off and on again before PTO engages.

1. Start engine and set to correct speed rating for PTO application. Observe tachometer (B) for engine speed.

Front PTO	Engine Speed (rpm)
1000	2100

NOTE: Operator must be seated when the PTO is engaged. PTO does not engage if the operator is absent.

2. Push down and forward on front PTO switch (A) to engage PTO. Front PTO indicator (C) illuminates on the primary display.

Scenario	1	2
Machine Movement	Parked or Stationary	Moving above 0.5 km/h (0.31 mph)
Remote PTO Enable Switch	Off	Off
Rear PTO Switch	Engaged	Engaged
Operator	Leaves seat	Leaves seat
Alarm	7 seconds	10 seconds
Rear PTO	Shuts Off after 7 seconds	Stays On
To Keep PTO Enabled	Return to seat or depress the remote PTO enable switch within 7 seconds	No action required
Front PTO	Functions the same as rear PTO	Functions the same as rear PTO

3. Pull front PTO switch (A) rearward to disengage PTO.

D3K5H22,00005CA-19-19APR21

PTO Automatic Disengage

NOTE: The PTO will disengage automatically after 7 seconds if the operator leaves the seat with the PTO engaged.

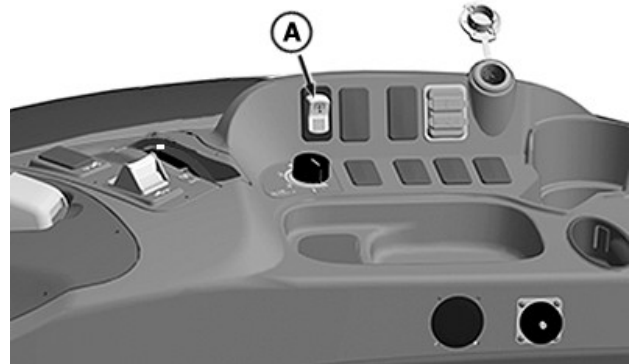

RXA0181050—UN—09FEB21

- A—Remote PTO Enable Switch

If continuous PTO operation is required and the operator must exit the seat, perform the following procedure:

1. With PTO running, park the machine.
2. Depress the remote PTO enable switch (A).
3. Exit the seat as needed.
4. Return to seat, continue operation.

NOTE: Each time the operator leaves the seat, the remote PTO enable switch must be activated.

MP60050,00009FE-19-15FEB21

PTO Alarm

Alarm Events

An alarm sounds to alert the operator that the PTO is running. See the following scenarios:

Power Take-Off (PTO) Operation

No Alarm Events

There will not be an alarm in the following scenarios:

Scenario	1	2 ^a	3
Machine Movement	Parked, Stationary, or Moving	Parked or Stationary	Parked, Stationary, or Moving
Remote PTO Enable Switch	Off	Engaged after the PTO switch	Off
PTO Switch	Engaged	Engaged	Engaged
Operator	Remains in seat	Leaves the seat	Not in seat when the PTO switch was engaged
Alarm	None	None	None
Rear PTO	Stays On	Stays On	Remains Off
To Keep PTO Enabled	No action required	No action required	Return to seat and restart PTO
Front PTO	Functions the same as rear PTO	Functions the same as rear PTO	Functions the same as rear PTO

^aMachines without rear fender PTO switches.

rp32883,1675417337713-19-03FEB23

Steering and Brake Operation

Service Brakes

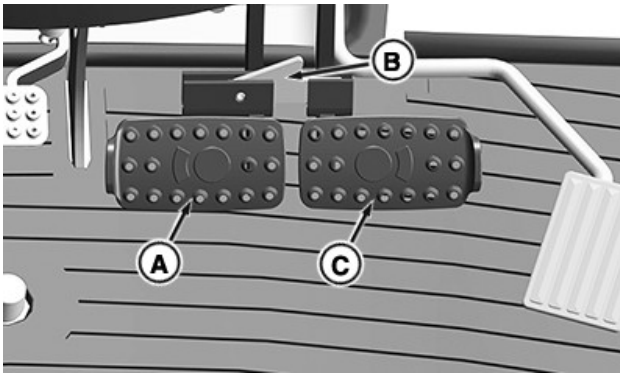

RXA0153748—UN—07SEP16

- A—Left Brake Pedal
- B—Brake Pedal Lock
- C—Right Brake Pedal

IMPORTANT: To prevent unnecessary wear, never operate with a foot resting on the brake pedals.

- For field work, unlock brake pedals. Apply right brake pedal (C) lightly to assist in making sharp right-hand turns and left brake pedal (A) for left-hand turns.
- Before operating machine on a road or transporting, use brake pedal lock (B) to hold brake pedals together.
- Use brakes lightly and cautiously at transport speeds.
- Reduce speed if towed load is not equipped with brakes and weighs more than the machine.
- Avoid hard braking applications. Consult implement operator's manual for recommended transport speeds.
- Use additional caution when transporting towed loads under adverse conditions, and when turning or stopping on inclines.

GS25068,00053CD-19-19SEP18

AutoTrac Steering System with GreenStar Display

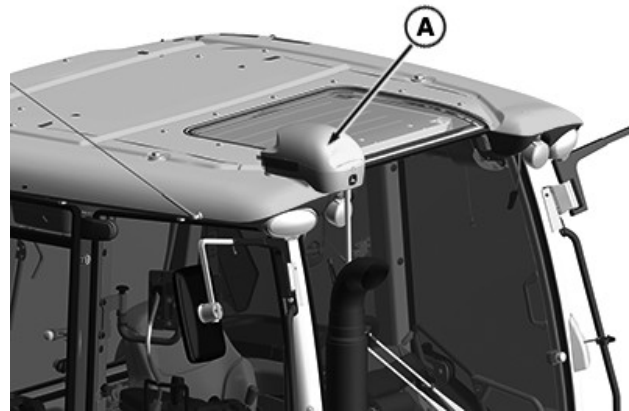

RXA0164103—UN—09AUG18

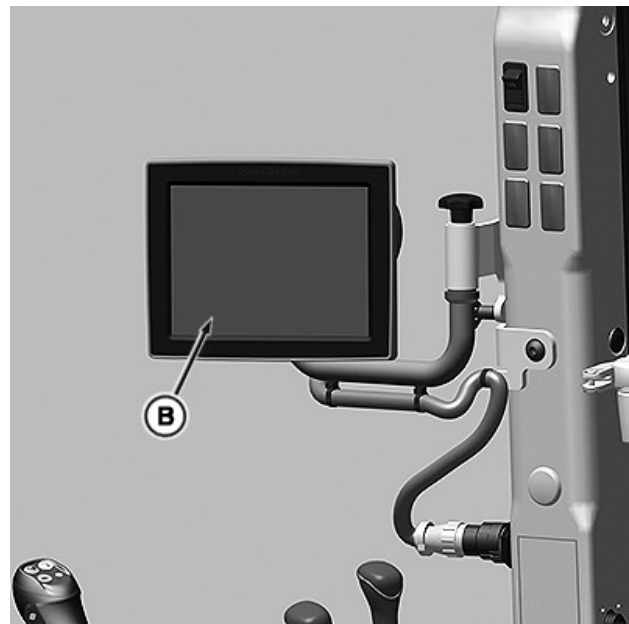

RXA0181052—UN—11FEB21



RXA0181051—UN—11FEB21

- A—StarFire Position Receiver
- B—GreenStar Display
- C—AutoTrac Resume Button

NOTE: See the relevant AutoTrac Operator's Manual for more information on the installation, operation, and maintenance.

NOTE: If the GreenStar Display is disconnected, AutoTrac Basic will be available at the next key cycle.

AutoTrac steering system uses the StarFire Position Receiver (A) and the GreenStar Display (B) to support the operator when steering the machine.

AutoTrac is a guidance system. The operator can take control of the machine at any time by actively turning the steering wheel. Travel speed is controlled exclusively by the operator, who uses the brake or actuates the foot speed control or hand speed control. Operator must turn machine to avoid any field obstacles and at the end of each pass. The operator must press the AutoTrac resume button (C) to engage AutoTrac.

NOTE: See GPS Receiver Offset Values in this section for GPS receiver offset values.

MP60050,0000B01-19-19MAY21

AutoTrac Basic Steering System with Front Console Display

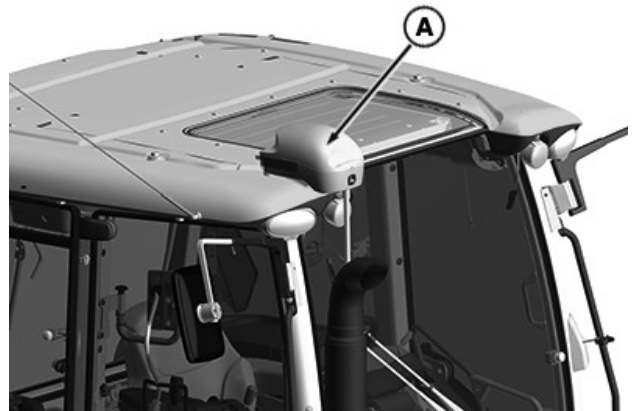

RXA0164103—UN—09AUG18



RXA0181053—UN—11FEB21



RXA0181051—UN—11FEB21

- A—StarFire Position Receiver
- B—Front Console Display
- C—AutoTrac Resume Button

NOTE: If the GreenStar Display is connected, AutoTrac Basic will not be available at the next key cycle.

AutoTrac Basic steering system uses the StarFire Position Receiver (A) and the left screen on front console display (B) to support the operator when steering of the machine.

AutoTrac Basic is a straight track guidance system. The operator can take control of the machine at any time by actively turning the steering wheel. Travel speed is controlled exclusively by the operator, who uses the brake or actuates the foot speed control or hand speed control. Operator must turn machine to avoid any field obstacles and at the end of each pass. The operator must press the AutoTrac resume button (C) to engage AutoTrac Basic.

MP60050,0000B03-19-19MAY21

Operate Guidance Systems Safely

Do not use guidance systems on roadways. Always turn off (disable) guidance systems before entering a roadway. Do not attempt to turn on (activate) a guidance system while transporting on a roadway.

Guidance systems are intended to aid the operator in performing field operations more efficiently. The operator is always responsible for the machine path. Guidance systems do not automatically detect or prevent collisions with obstacles or other machines.

Guidance systems include any application that automates machine steering. This includes, but may not be limited to, AutoTrac, AutoTrac Turn Automation,

AutoTrac Implement Guidance (passive), AutoTrac Basic, AutoTrac Universal, RowSense, and Machine Sync.

To prevent injury to the operator and bystanders:

- Never get on or off a moving machine.
- Verify that the machine, implement, and guidance system are set up correctly.
 - If using AutoTrac Turn Automation, or AutoTrac Implement Guidance (passive), verify that accurate boundaries have been defined.
 - If using Machine Sync, verify that the follower's home point is calibrated with sufficient space between the machines.
- Remain alert and pay attention to the surrounding environment.
- Take control of the steering wheel, when necessary, to avoid field hazards, bystanders, equipment, or other obstacles.
- Stop operation if poor visibility conditions impair your ability to operate the machine or identify people or obstacles in the machine path.
- Consider field conditions, visibility, and machine configuration when selecting machine speed.

MP60050,0000AD2-19-05MAY21

Enable AutoTrac Basic

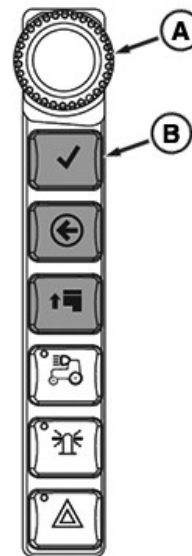

RXA0181055—UN—11FEB21

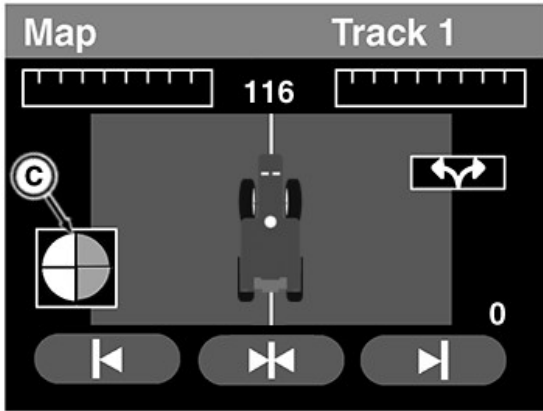

RXA0178551—UN—26JUN20

- A—Navigation Dial
- B—Confirm Button
- C—AutoTrac Status Pie

1. Scroll with the navigation dial (A) on the navigation pad to the AutoTrac status pie (C) on the AutoTrac Basic map screen.
2. Press the confirm button (B) on the navigation pad to enable “Steer On.”
3. Press the confirm button (B) again on the navigation pad to disengage AutoTrac Basic.

MP60050,0000B04-19-19MAY21

Disable AutoTrac Basic

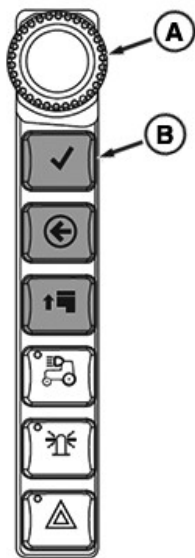

RXA0181055—UN—11FEB21

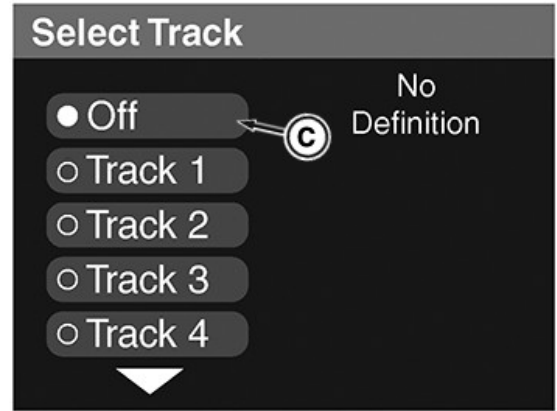

RXA0170767—UN—08OCT19

- A—Navigation Dial
- B—Confirm Button
- C—Off Selected Track

CAUTION: Always turn off (deactivate and disable) AutoTrac Basic system before entering a roadway.

1. Scroll with the navigation dial (A) on the navigation pad to the AutoTrac Basic track setup selection.
2. Press the confirm button (B) on the navigation pad to enter AutoTrac Basic track setup.
3. Select “Off” (C) on the track selection screen to disable AutoTrac Basic.

MP60050,0000B05-19-19MAY21

AutoTrac Resume Switch



RXA0181054—UN—11FEB21

A—AutoTrac Resume Switch

Press the AutoTrac resume switch (A) on the armrest or right-hand console key pad to move AutoTrac Basic from the enabled stage to the activated stage.

MP60050,0000B06-19-19MAY21

3. Manually activate AutoTrac Basic when steering assistance is desired by pressing the AutoTrac resume switch. This initiates assisted steering.

MP60050,0000B07-19-19MAY21

Activate AutoTrac Basic

CAUTION: While AutoTrac Basic is activated, operator is responsible for steering at the end of path and collision avoidance.

CAUTION: Do not attempt to turn on (activate) AutoTrac Basic system while transporting on a roadway.

1. Select Steer on-off to enable “Steer On.”
2. Drive the machine onto a guidance track and a highlighted navigation line appears in front of the machine icon.

Disengage AutoTrac Basic

AutoTrac Basic system is disengaged by:

- Turning steering wheel.
- Slowing to speeds less than 0.5 km/h (0.3 mph).
- Selecting Steer on-off to disengage AutoTrac Basic.
- Operator remaining out of seat for more than 7 seconds if using seat switch, or no activity is detected by operator presence monitor for 7 minutes.

MP60050,0000B08-19-19MAY21

Reactivate AutoTrac Basic on Next Pass

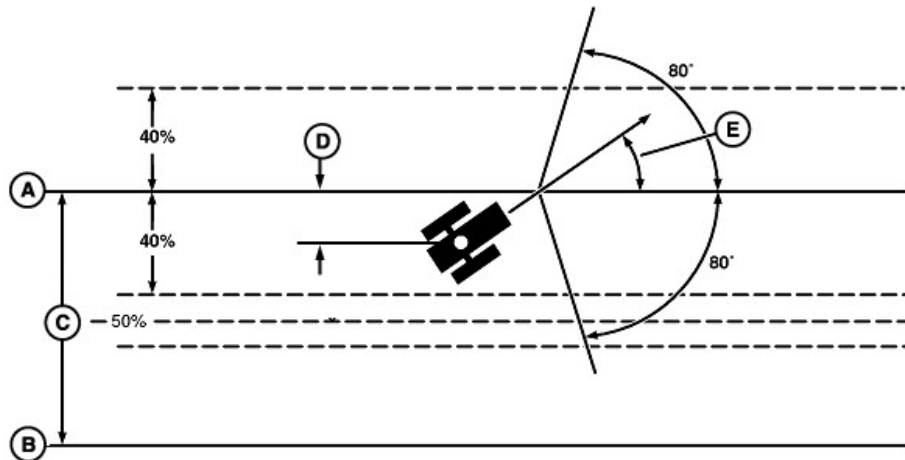

Tracking

PC8866—UN—02NOV05

A—Track 0
B—Track 1 South
C—Track Spacing

D—Off-Track Lateral Error
E—Track Heading Error

Once the end of the row is reached, the operator must turn system to next pass. By turning steering wheel, AutoTrac Basic is deactivated.

AutoTrac Basic can be activated again by pressing the AutoTrac resume switch only after following conditions are met:

- In reverse, AutoTrac Basic remains activated for 45 seconds. After 45 seconds, the machine must be put in a forward gear before reverse activates again.
- Machine heading is within 80° of desired track.
- The machine is within 40% of track spacing.
- Operator is seated.
- TCM is on.

- Steering controller determines highest speed while using AutoTrac Basic.
- Forward machine speed is less than 30 km/h (18.6 mph).
- Reverse speed is less than 10 km/h (6 mph).

MP60050,0000B09-19-19MAY21

AutoTrac Basic Menu

NOTE: For additional navigation information, see Basic Menu Navigation in the Displays, Software, and Electronics Operation section.



AutoTrac Basic Menu

RXA0170082—UN—10SEP19

1. Locate the AutoTrac Basic menu.

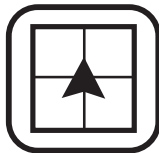

Map Selection

RXA0178552—UN—26JUN20

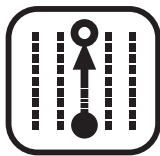

Track Setup Selection

RXA0170084—UN—10SEP19

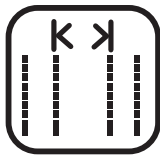

Track Width Selection

RXA0170085—UN—10SEP19

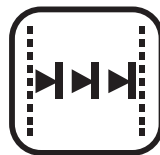

Shift Size Selection

RXA0170086—UN—10SEP19



Vehicle Selection

RXA0170087—UN—10SEP19



Tuning Selection

RXA0170088—UN—10SEP19

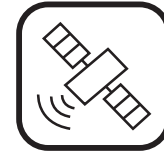

Correction Mode Selection

RXA0170089—UN—10SEP19



TCM Calibration Selection

RXA0170090—UN—10SEP19

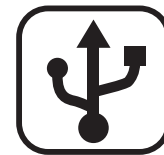

USB Drive Selection

RXA0170091—UN—10SEP19



GPS Status Selection

RXA0170092—UN—10SEP19



About Selection

RXA0170093—UN—10SEP19

2. Select and change the desired setting as needed. See the relevant topic in this section for additional details on settings.

MP60050,0000B0A-19-19MAY21

AutoTrac Basic Map

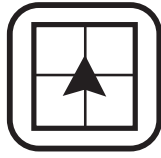

Map Icon

RXA0178552—UN—26JUN20



Turn Predictor Icon

RXA0170097—UN—17SEP19

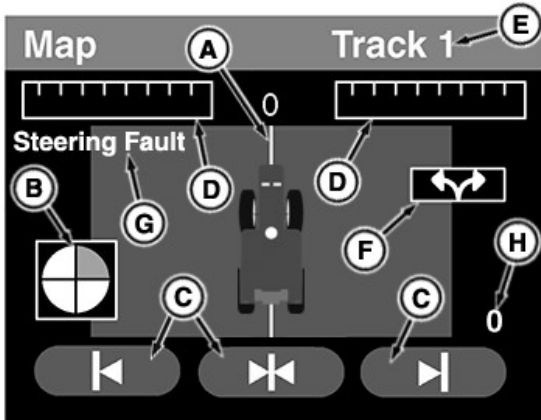

RXA0178553—UN—26JUN20

- A—Guidance Line
- B—AutoTrac Status Pie
- C—Shift Track Buttons (3)
- D—Light Bar
- E—Guidance Off/Selected Track
- F—Turn Predictor
- G—AutoTrac Exit Code
- H—Track Number

The map screen displays the machine location relative to the guidance line (A). It also shows the AutoTrac status pie (B), shift track buttons (C), lightbar (D), guidance off/selected track (E), turn predictor (F), and exit code text (G).

Lightbar

The lightbar provides off-track error feedback to the operator. The feedback is shown on the lightbar located above the main run screen.

The minimum error step size is 1 in or 1 cm, depending on the unit type selected (English or metric).

The step size setting is not configurable.

The lightbar indicates error in the steer towards direction, meaning that the AutoTrac Basic system must steer towards the line to reduce the error shown by the lightbar.

Turn Predictor

Turn predictor alerts the operator by predicting the end of pass and displays the distance to the end of the pass in the map view.

Turn predictor is intended to predict only the turn point of a machine. It is NOT a headland alert. Turn predictions are based solely on previous turn behavior of machine. Turn predictions are inaccurate if the field boundary is not linear and continuous, or if the operator turns before or after field boundary.

Distance counts down to predicted turn, and tones sound when machine is 10 seconds from intersecting turn point. This happens again when predicted turn point has been reached.

Visual indicator will change to yellow within 10 seconds of predicted turn, then red after passing the predicted turn location.

Scroll with the navigation dial on the navigation pad to the turn predictor icon. Press the confirm button on the navigation pad to disable the turn predictor. Press the confirm button on the navigation pad again to enable the turn predictor.

Once disabled, it remains off until it is manually turned back on by the operator. The turn predictor icon becomes gray with a diagonal line through the image when disabled.

Whenever the turn predictor is enabled, the turn predictor icon is a non-gray image without a diagonal line through the image.

Track Number

The track number (H) indicates which track the machine is on based upon the original created track. The created track is indicated by a zero on the display. Tracks to the right of the created track are positive increments 1, 2, and so on. Tracks to the left are negative increments -1, -2, and so on.

MP60050,0000B02-19-19MAY21

AutoTrac Status Pie

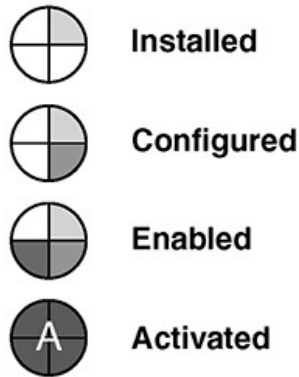

RXA0170098—UN—30SEP19
AutoTrac Status Pie Icon

- AutoTrac resume button has been pressed and AutoTrac Basic is steering the machine.
- Speed is within valid range.
- Heading/angle is within valid range.
- Machine is within 40% of track spacing.

MP60050,0000B0B-19-19MAY21

AutoTrac Basic Track Setup

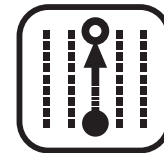

RXA0170084—UN—10SEP19
Track Setup Icon

Installed

Steering controller and all other hardware necessary for use are installed. System is disabled.

- AutoTrac Basic controller is installed.
- Steering controller is detected.

Configured

A valid track has been established. Correct StarFire signal level is selected. System is ready to be enabled.

The following machine conditions are met:

- Guidance system is turned ON.
- Guidance track is defined.
- StarFire signal is present.
- Steering controller has no active faults.
- Speed is in range.
- TCM message is available and valid.
- Machine is in proper operating gear.
- Variable rate of steer switch is enabled.

Enabled

AutoTrac on-off button has been pressed. All conditions are met for AutoTrac to operate and system is ready to be activated.

- Select Steer on-off to enable “Steer On”.

Activated

AutoTrac resume button pressed and AutoTrac steering the machine.

The following machine conditions are met:

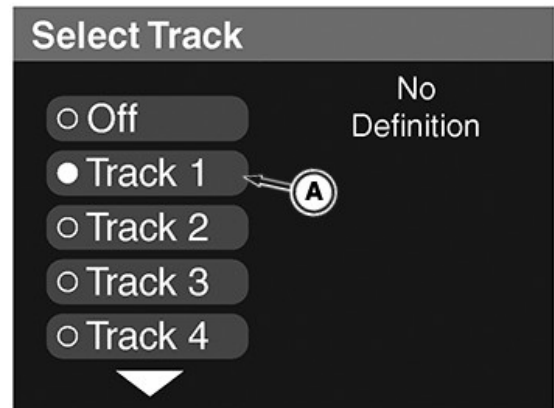

RXA0170099—UN—08OCT19
Track Selection Screen

A—Pre-Named Guidance Tracks (10)

AutoTrac Basic is a straight track guidance system only.

A maximum of ten pre-named guidance tracks (A) are available. Operators cannot modify track names or delete tracks from the set.

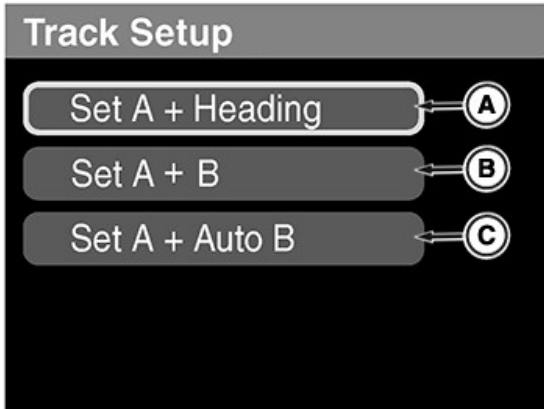

RXA0170100—UN—14OCT19

Track Setup Screen

Straight track setup options include:

- A - Set A + Heading
- B - Set A + B
- C - Set A + Auto B

B—Heading Degree

Set A + Heading

Operator sets desired A point (A). The operator drives the machine and the heading automatically populates to the nearest whole degree from the current GPS course. Operator can either accept the automatically populated heading value (B) or modify the heading degree as needed.

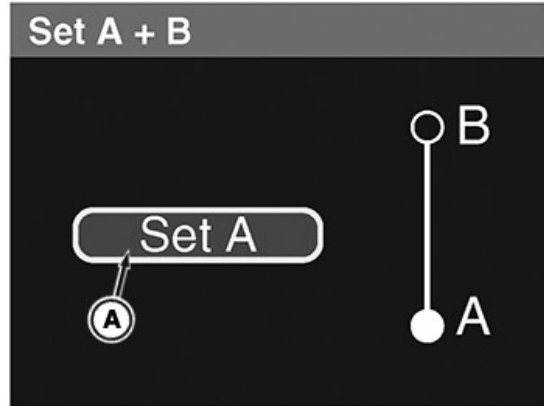

RXA0170435—UN—08OCT19

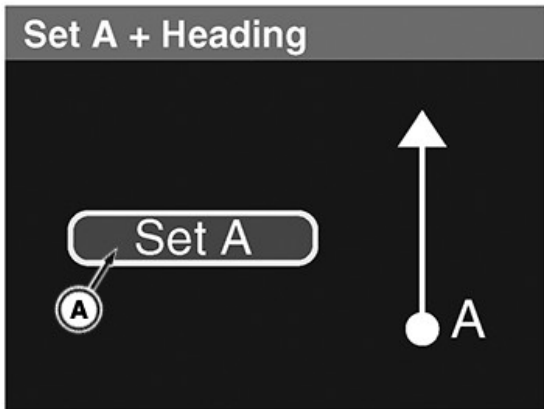

RXA0170432—UN—08OCT19

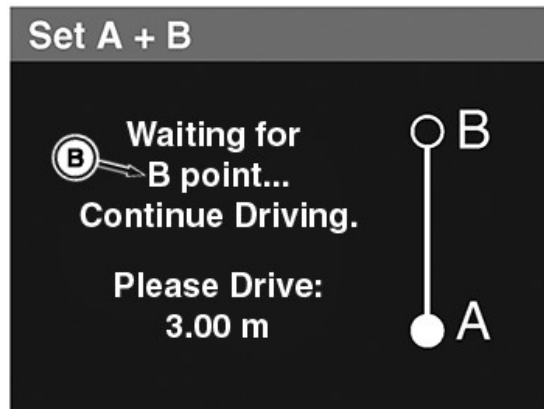

RXA0178555—UN—26JUN20

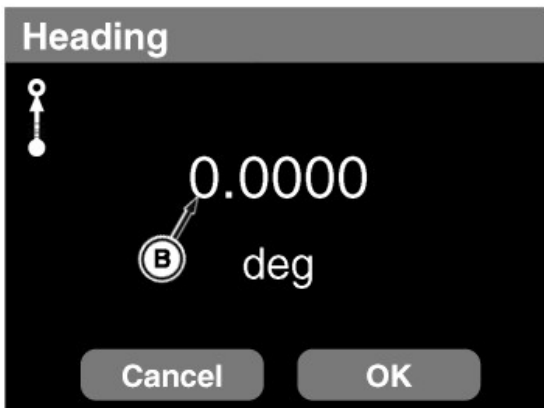

RXA0178554—UN—26JUN20

A—Set Desired A Point

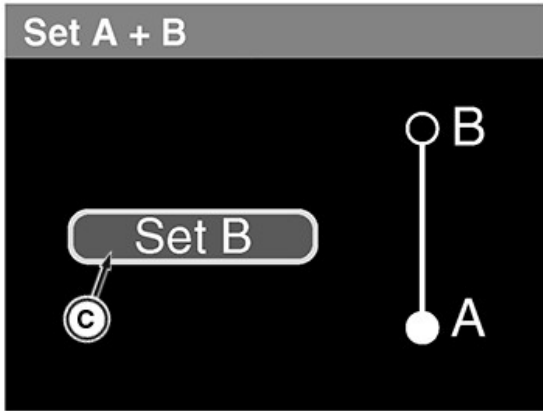

RXA0170437—UN—08OCT19

- A—Set Desired A Point
- B—“Waiting for B Point... Continue Driving.” Screen
- C—Set Desired B Point

Set A + B

Operator sets desired A point (A). The operator drives the machine and screen (B) appears until operator is allowed to set B point (C).

B—Continue Driving. B point will automatically set once distance is sufficient. Screen

Set A + Auto B

Operator sets desired A point (A). The operator drives the machine and screen (B) appears until B point is automatically set.

After each line creation, the AutoTrac status pie jumps to “Enable”. The operator can press the AutoTrac resume button on the key pad to transition the AutoTrac status pie to “Activate”.

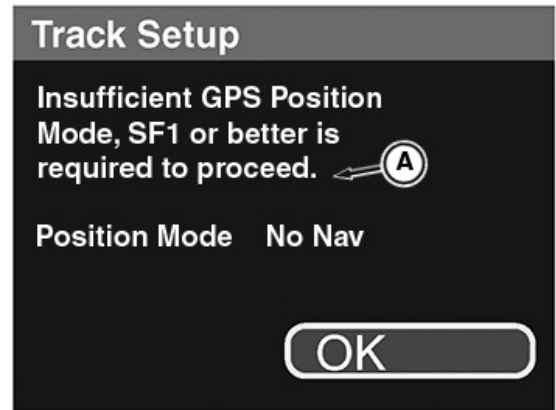

RXA0170440—UN—08OCT19

A—“Insufficient GPS Position Mode, SF1 or better is required to proceed. Position Mode No Nav” Screen

When the StarFire receiver does not have an appropriate signal in order to set up a guidance line, screen (A) appears.

MP60050,0000B0C-19-19MAY21

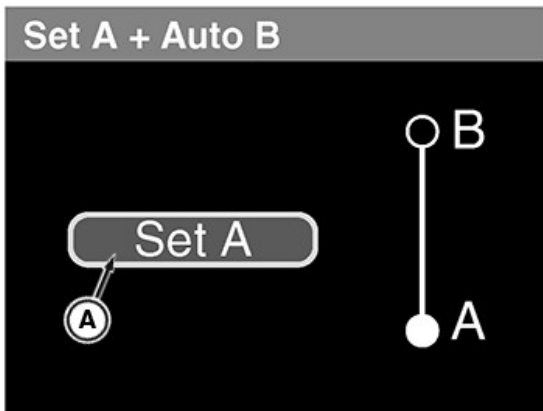

RXA0170438—UN—08OCT19

AutoTrac Basic Track Width

NOTE: Operators can select display to show metric or standard units.

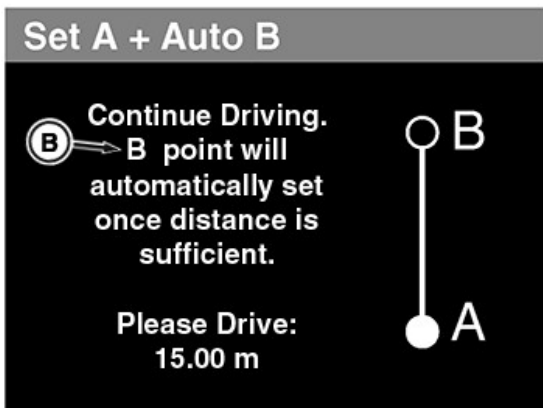

RXA0178556—UN—26JUN20

A—Set Desired A Point

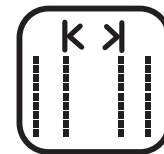

RXA0170085—UN—10SEP19

Track Width Icon

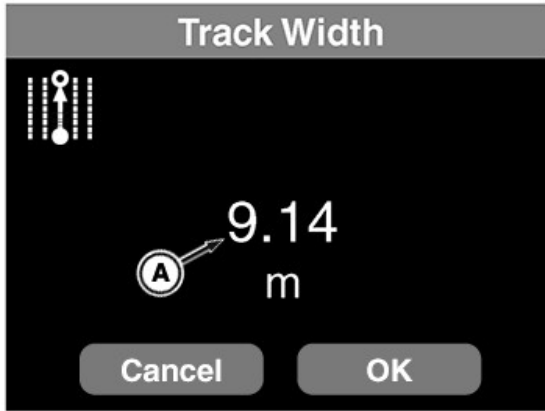

A—Track Width (metric units shown)

RXA0178557—UN—26JUN20

Operators can enter track width (A) changes manually in measurements of meters or feet and inches. Track width is not linked to implement profiles and does not automatically update. Implement profiles do not exist with AutoTrac Basic.

MP60050,0000B0D-19-19MAY21

AutoTrac Basic Shift Size

NOTE: Operators can select display to show metric or standard units.

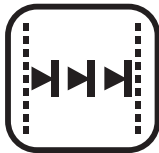

Shift Size Icon

RXA0170086—UN—10SEP19

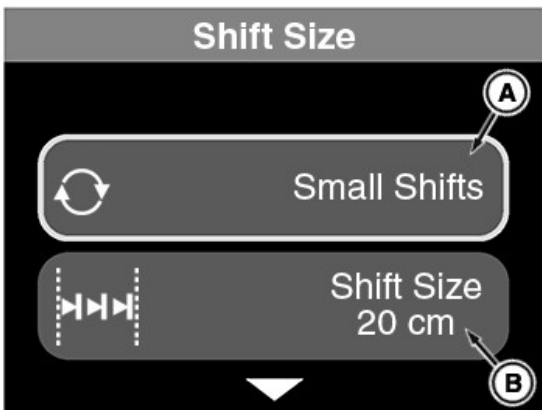

Small Shift Page

RXA0178558—UN—26JUN20

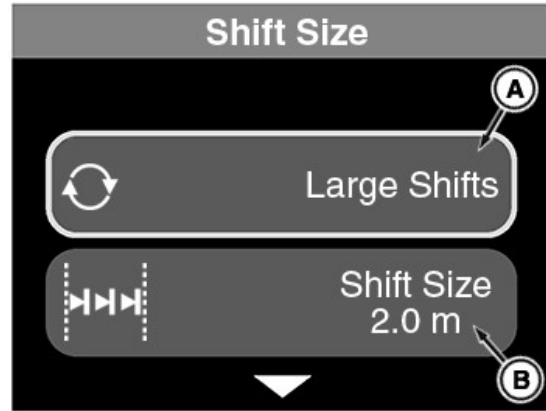

Large Shift Page

RXA0178559—UN—26JUN20

A—Shift Size Selection
B—Shift Size

Select small or large shift (A) to adjust the shift size (B) to the desired value.

Small shifts are 31 cm (12 in) or less.

Large shifts are greater than 31 cm (12 in).

NOTE: Only small shifts of 31 cm (12 in) or less are allowed while AutoTrac is activated.

Large shifts are not allowed when AutoTrac is activated. They are allowed in the configuration and enabled modes.

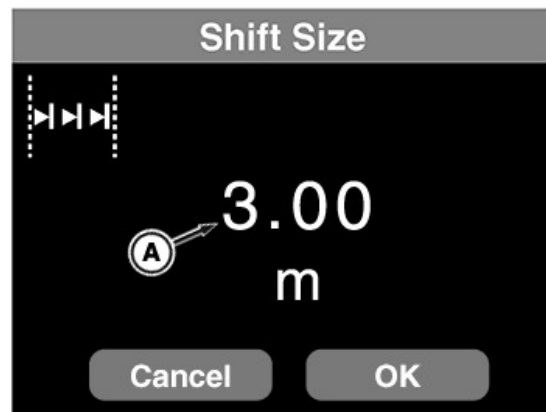

RXA0178560—UN—26JUN20

A—Shift Increment

Shift increment (A) defaults to zero. Adjust shift increment value as needed and select OK to save.

The left shift, center shift, and right shift buttons are available on the bottom of the main map screen.

Selecting the left and right shift buttons moves the currently selected guidance line respectively by the shift increment amount.

Selecting the center shift button moves the currently selected guidance line to the current machine position.

Total shift magnitude is stored with each track. This allows the operator to come back to a previously shifted track and maintain the shifted location.

MP60050,0000B0E-19-19MAY21

AutoTrac Basic Vehicle

NOTE: Operators can select display to show metric or standard units.

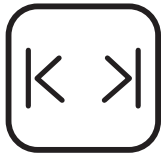

Vehicle Icon

RXA0170087—UN—10SEP19

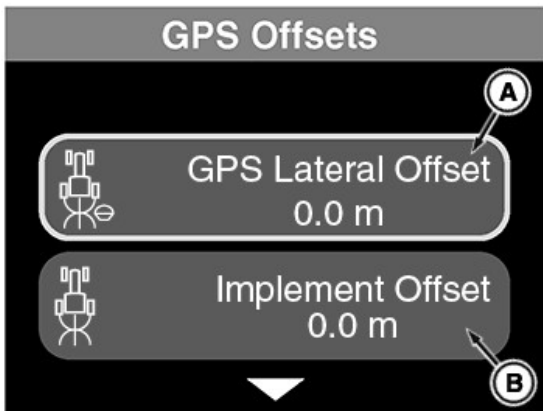

RXA0178561—UN—26JUN20



RXA0178562—UN—26JUN20

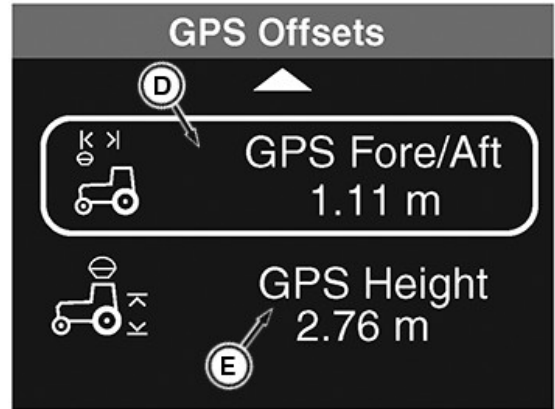

RXA0170450—UN—08OCT19

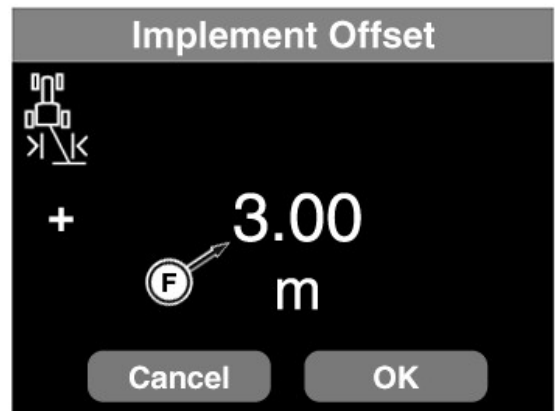

RXA0178563—UN—26JUN20

- A—GPS Lateral Offset
- B—Implement Offset
- C—GPS Lateral Offset Measurement (metric units shown)
- D—GPS Fore/Aft
- E—GPS Height
- F—Implement Offset Measurement (metric units shown)

NOTE: See GPS Receiver Offset Values in this section for GPS receiver offset values.

GPS lateral offset (A) and implement offset (B) are adjustable. The values are set to zero by default and can be reset.

The GPS lateral offset is to adjust the machine centerline if needed. Navigate to the GPS lateral offset page and adjust the value (C), either positive (right) or negative (left) as needed. Select OK to save the value.

If an offset implement is used and operator desires to have the center of the implement track to the guidance line. Navigate to the implement offset page and adjust the value (F), either positive (right) or negative (left) as needed. Select OK to save the value.

GPS fore/aft (D) and GPS height (E) are detected automatically and populated from the machine steering control unit. GPS fore/aft and GPS height are not editable.

GPS lateral offset (A) defaults to the appropriate machine offset using VIN detection that is based on receiver mounting location.

GPS lateral offset measurement (C) is editable by the operator after the initial detection.

MP60050,000B0F-19-19MAY21

AutoTrac Basic Tuning



Tuning Icon

RXA0170088—UN—10SEP19

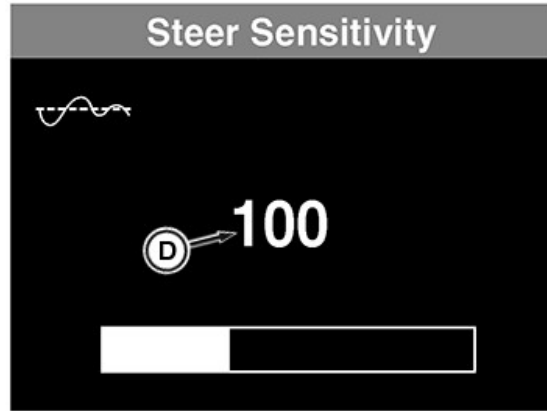

RXA0170453—UN—08OCT19

- A—Steer Sensitivity
- B—Advanced Settings
- C—Reset To Defaults
- D—Steer Sensitivity Range

AutoTrac Basic is equipped with steer sensitivity (A) and advanced settings (B). Adjust steer sensitivity (A) between a range (D) of 50—200. Advanced settings (B) guide the operator to the full list of AutoTrac Basic advanced settings. A reset to defaults (C) is also available.

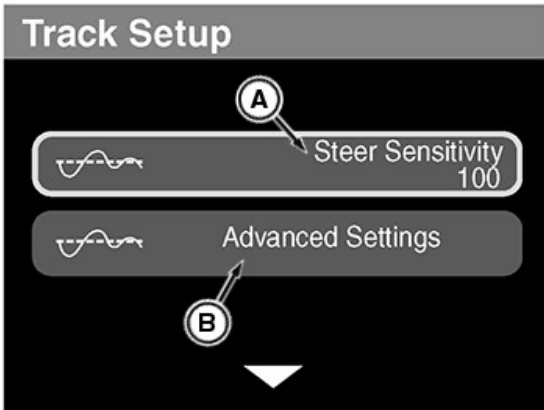

RXA0170451—UN—08OCT19

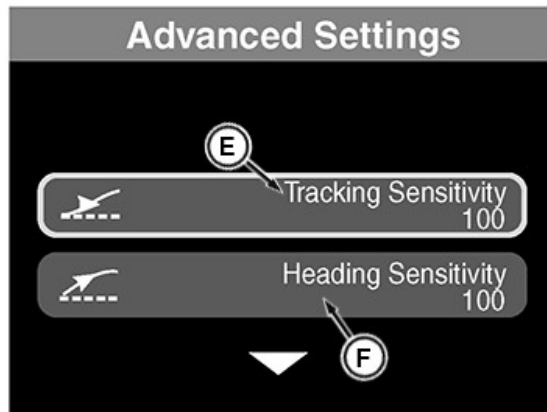

RXA0170454—UN—08OCT19

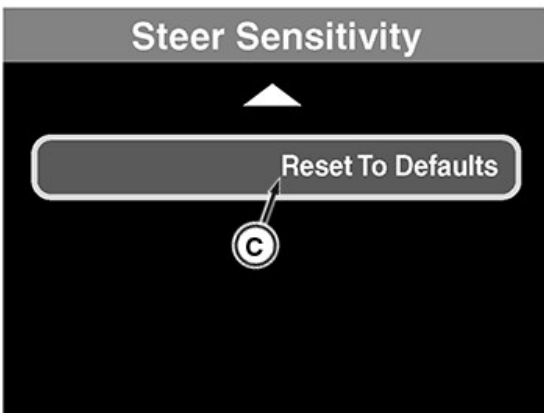

RXA0170452—UN—08OCT19

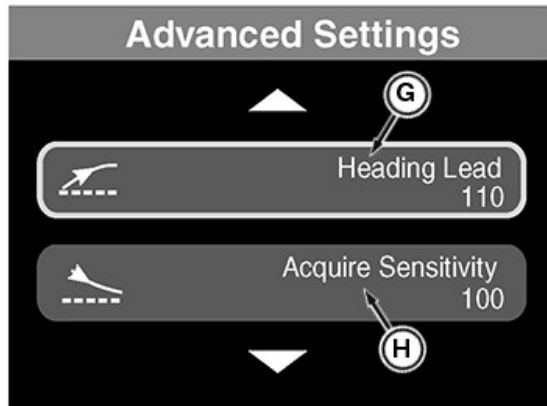

RXA0170455—UN—08OCT19

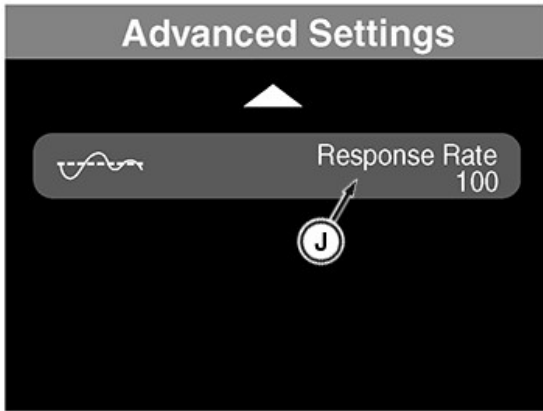

RXA0170456—UN—08OCT19

- E—Tracking Sensitivity
- F—Heading Sensitivity
- G—Heading Lead
- H—Acquire Sensitivity
- I—Response Rate

Advanced Settings are default programmed into the steering control unit. Ranges for advanced settings are 50—200.

MP60050,0000B10-19-19MAY21

The correction mode shows the status (A) of the StarFire signal:

- SF1
- SF3
- RTK (Real Time Kinematic) (Only shown if RTK was enabled previously via universal display.)
- M-RTK (Machine-Real Time Kinematic) (Only shown if M-RTK was enabled previously via universal display.)

NOTE: Operator cannot enter RTK or M-RTK through the corner post display. Connect with a universal display is required to enter RTK or M-RTK.

MP60050,0000B11-19-19MAY21

AutoTrac Basic TCM Calibration



RXA0170090—UN—10SEP19

TCM Calibration Icon

StarFire Correction Mode

NOTE: For more information, see the relevant StarFire Receiver Operator Manual.



RXA0170089—UN—10SEP19

Correction Mode Icon

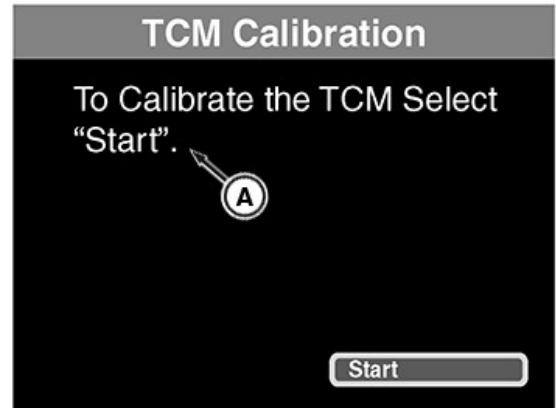

RXA0170458—UN—08OCT19



RXA0170457—UN—08OCT19

A—StarFire Status

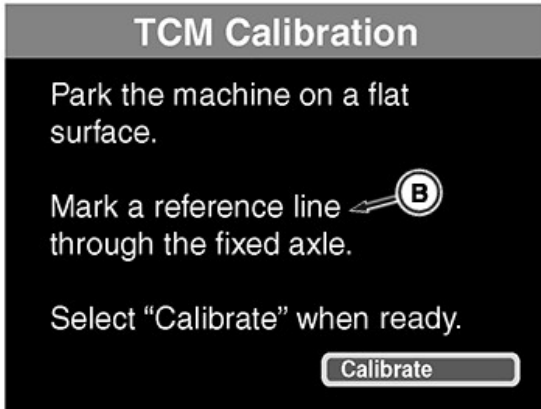

RXA0181091—UN—06MAY21

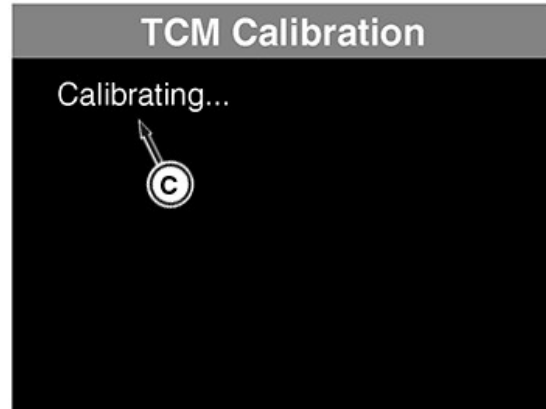

RXA0170460—UN—08OCT19

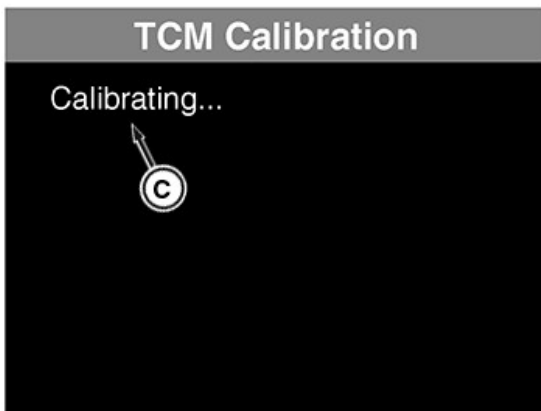

RXA0170460—UN—08OCT19

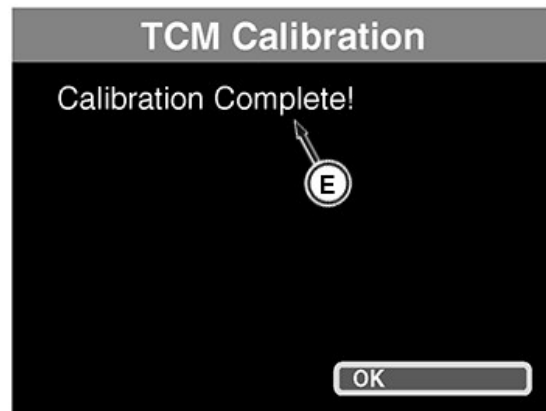

RXA0170462—UN—08OCT19

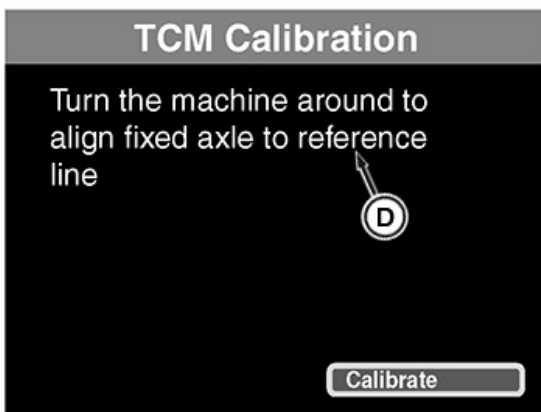

RXA0170461—UN—08OCT19

- A—"To Calibrate the TCM Select "Start"." Screen
- B—"Park the machine on a flat surface. Mark a reference line through the fixed axle. Select "Calibrate" when" Screen
- C—"Calibrating..." Screen
- D—"Turn the machine around to align fixed axle to reference line" Screen
- E—"Calibration Complete!" Screen

NOTE: Before calibrating, ensure that machine and implement are in proper working condition and ready for field work.

Machine must be ballasted and tires properly inflated.

Lower implement as close as possible to working position when calibrating.

NOTE: Calibrate TCM every time receiver is removed from machine and re-attached or if TCM angle in relation to machine has changed.

The operator calibrates the terrain compensation module (TCM) so the StarFire Receiver can determine 0° roll angle and pitch angle.

The operator performs the on-screen calibration procedure.

1. The operator selects "Start" on the start calibrate screen (A).
2. Instruction screen (B) appears.
3. The operator positions the machine and selects "Calibrate".
4. The operator leaves the machine in park.
5. Calibrating screen (C) appears.
6. Instruction screen (D) appears.
7. The operator positions the machine and selects "Calibrate".
8. The operator leaves the machine in park.
9. Calibrating screen (C) appears again.
10. Calibration complete screen (E) appears.
11. The operator selects "OK" to complete the calibration.

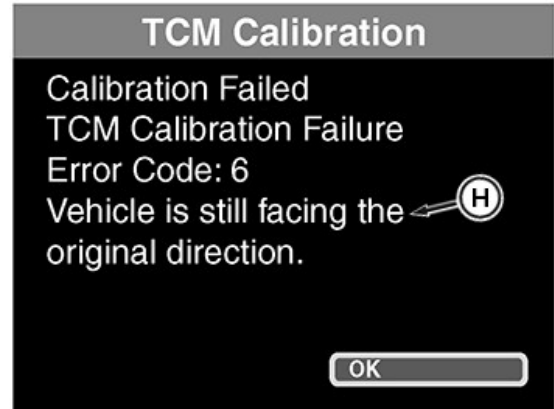

RXA0170570—UN—08OCT19

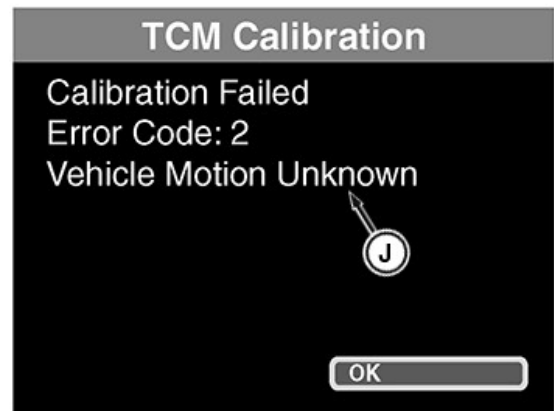

RXA0170571—UN—08OCT19

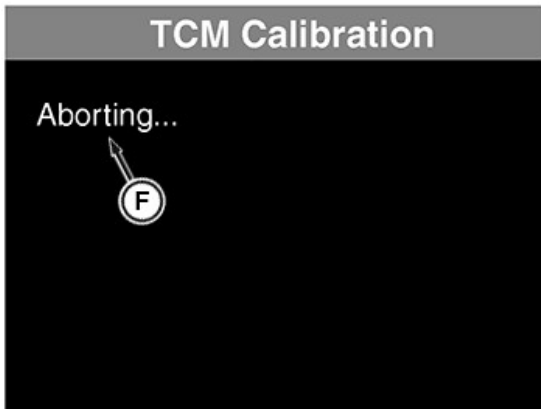

RXA0170568—UN—08OCT19

F—Aborting Screen

The operator can press the back button on the navigation pad to abort the TCM calibration. Aborting screen (F) appears.

- G—Calibration Failed. Error Code: 3 Vehicle Motion Unknown. Results Out of Range. Check vehicle position and bracket alignment Screen**
- H—Calibration Failed. TCM Calibration Failure. Error Code: 6 Vehicle is still facing the original direction Screen**
- J—Calibration Failed. Error Code: 2 Vehicle Motion Unknown Screen**

TCM Calibration Failed

Messages (G, H, or J) appear when TCM calibration fails. Repeat the TCM calibration process. If calibration fails again, contact your John Deere dealer.

MP60050,0000B12-19-19MAY21

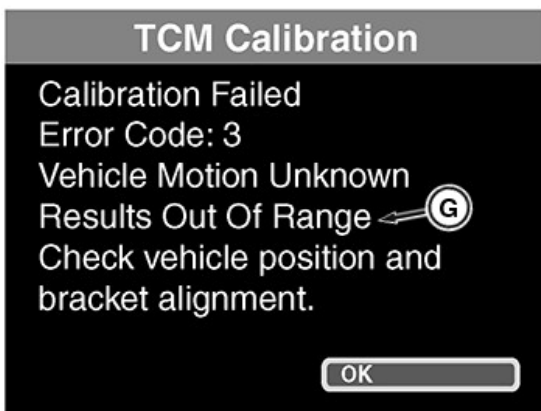

RXA0170569—UN—08OCT19

StarFire USB Drive

NOTE: For more information, see the relevant StarFire Receiver Operator's Manual.

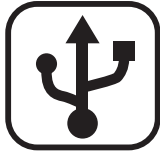

USB Drive Icon

RXA0170091—UN—10SEP19

- B—USB Update Progress Screen
- C—USB Update Complete Screen

When there is a StarFire USB drive inserted into the StarFire Receiver, an update software screen (A) appears. The StarFire USB drive updates the GPS software and a progress screen (B) appears. The status bar displays status of update in increments of 10%. An update complete screen (C) appears when the StarFire USB drive is finished updating the GPS software.

NOTE: StarFire Receiver reboots after a programming event.

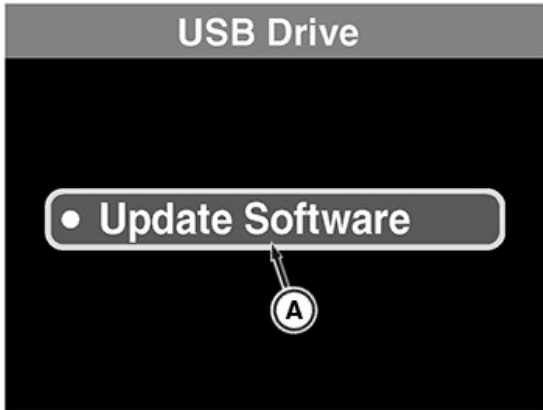

RXA0170463—UN—08OCT19

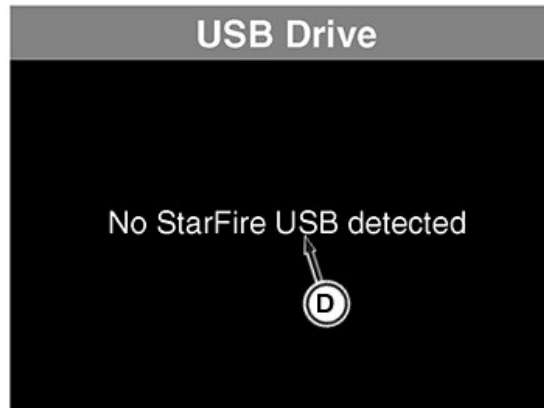

RXA0170466—UN—08OCT19

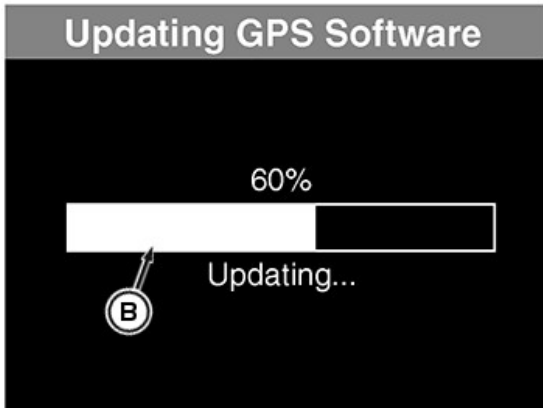

RXA0170464—UN—08OCT19

- D—"No StarFire USB detected" Screen

When there is a no StarFire USB drive inserted into the StarFire Receiver, a "No StarFire USB detected" screen (D) appears.

NOTE: If a USB drive is inserted and a "No StarFire USB detected" screen appears, unplug USB and insert a different one. Some USB drives are not compatible. If the error message continues to appear, see your John Deere dealer.

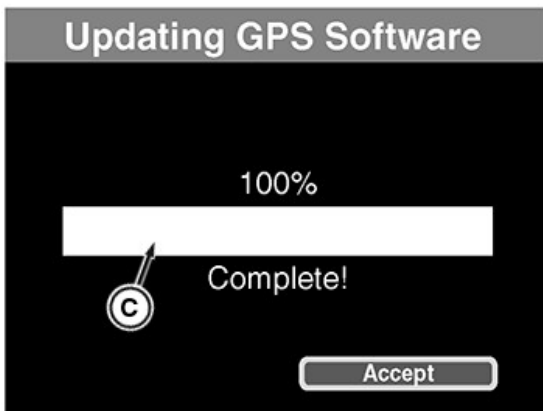

RXA0170465—UN—08OCT19

StarFire GPS Status

NOTE: For more information, see the relevant StarFire Receiver Operator's Manual.



GPS Status Icon

RXA0170092—UN—10SEP19

- A—USB Drive Update Software Screen

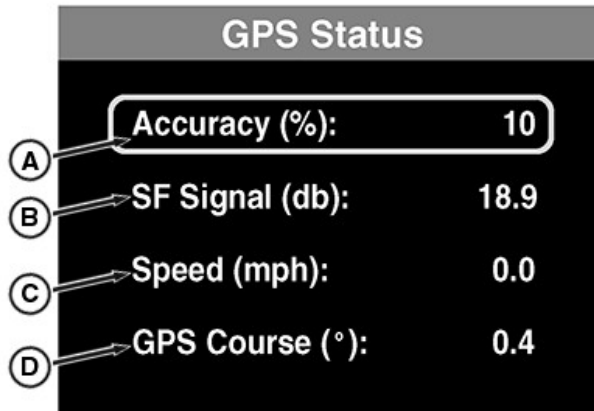

RXA0170467—UN—08OCT19

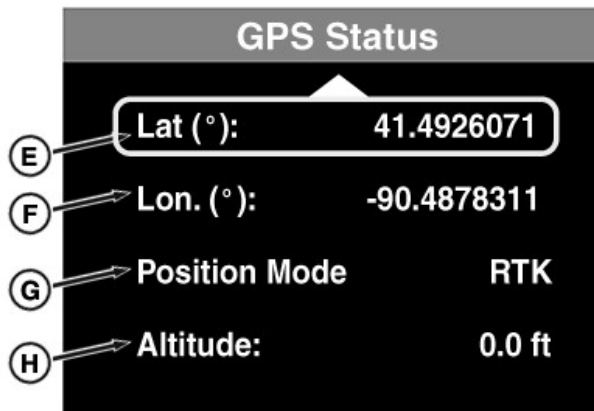

RXA0178564—UN—26JUN20

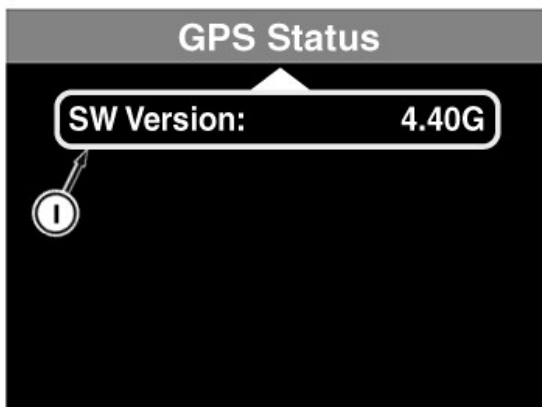

RXA0178565—UN—26JUN20

- A—Accuracy
- B—StarFire Receiver Signal
- C—Speed of Machine
- D—GPS Course
- E—Latitude
- F—Longitude
- G—Position Mode
- H—Altitude
- I—Software Version

NOTE: The values are not editable.

MP60050,0000B14-19-19MAY21

AutoTrac Basic Settings Locked

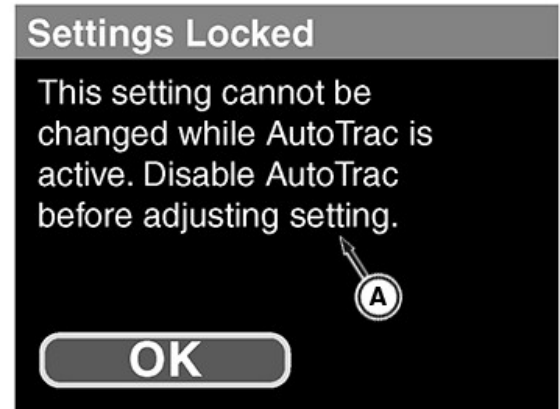

RXA0170470—UN—08OCT19

A—This setting cannot be changed while AutoTrac is active. Disable AutoTrac before adjusting setting Screen

The settings locked screen (A) is shown when trying to access the following menus while AutoTrac Basic is active:

- Track Width
- Vehicle
- TCM Calibration
- USB Drive

MP60050,0000B15-19-19MAY21

AutoTrac Basic About



About Icon

RXA0170093—UN—10SEP19

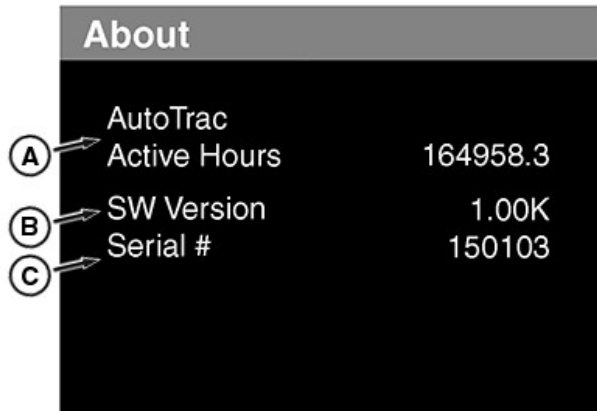

RXA0170469—UN—08OCT19

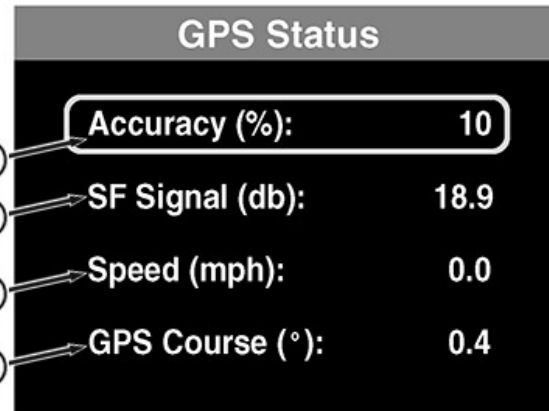

RXA0170467—UN—08OCT19

About displays:

A - AutoTrac Basic Active Hours

B - Software Version

C - Serial Number

NOTE: The values are not editable.

MP60050,0000B16-19-19MAY21

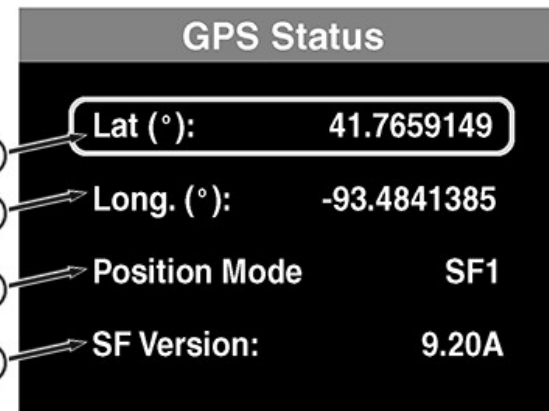

RXA0170468—UN—08OCT19

Autotrac Basic SF3000 Functionality



RXA0178566—UN—26JUN20

A—Acknowledgment Button

SF3000 is not fully supported through the machine display. If Correction Mode, TCM Calibration, or USB Drive is selected, a communication error screen appears. Select the acknowledgment button (A) to return to the menu.

The following information is available through the display:

- A**—Accuracy
- B**—StarFire Receiver Signal
- C**—Speed of Machine
- D**—GPS Course
- E**—Latitude
- F**—Longitude
- G**—Position Mode
- H**—Software Version

NOTE: The values are not editable.

MP60050,0000B17-19-19MAY21

GPS Receiver Offset Values

GPS Offset Values	
GPS Height	2043 mm (80.4 in) + Measurement from ground to center of rear axle
GPS Lateral Offset (right of the machine center)	523 mm (20.6 in)
GPS In-line (fore/aft) Offset	1112.5 mm (43.8 in)

MP60050,0000B18-19-19MAY21

AutoTrac Universal Information

 **CAUTION: Refer the AutoTrac Universal manual for safe and proper operation of the guidance system and ATU.**

The AutoTrac Universal (ATU) system uses the Global Positioning System (GPS) for guided steering of the machine. When AutoTrac Universal system is NOT active, the operator steers the machine manually.

See ATU reference manuals for more information on the installation, operation, and maintenance.

MP60050,0000B19-19-19MAY21

Hydraulics Operation

Warm Transmission/Hydraulic Oil

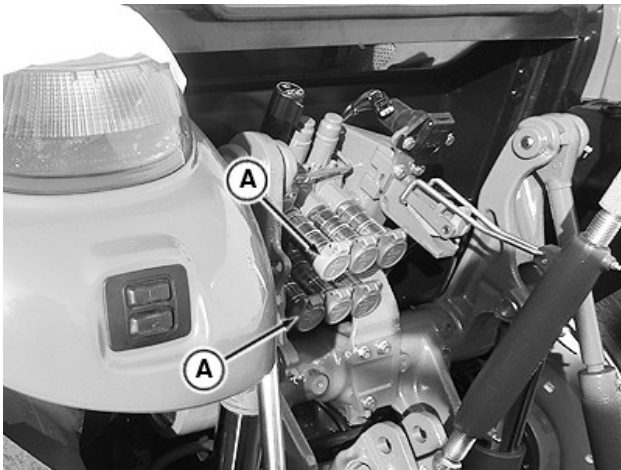

PY39983—UN—04MAY17

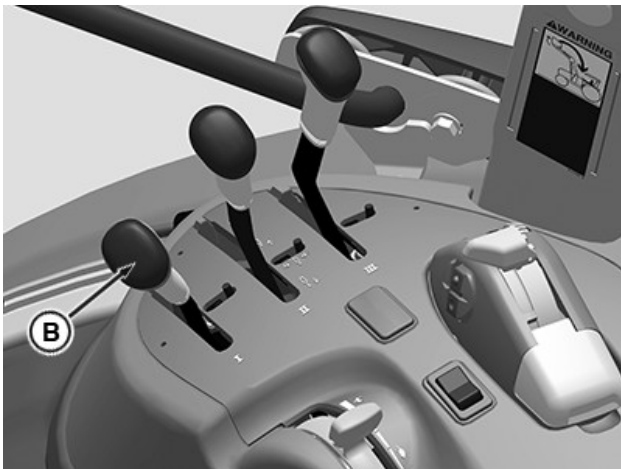

PY42028—UN—03MAY17

A—SCV I Couplers
B—SCV I Lever

Steering, transmission, and hydraulic systems are slow to function when machine is started in cold weather. To warm oil up quicker for improved cold-weather operation, follow procedure as required.

1. Connect jumper hose to SCV I couplers (A).
2. If SCV is equipped with flow control, open flow control knob fully to allow maximum flow.
3. Start engine and set idle to 1200 rpm.
4. Hold SCV I lever (B) forward or rearward until hydraulic oil warms to operating temperature.
5. To check warm-up progress, turn steering wheel side-to-side. When the wheel turns smoothly without hesitation, oil has warmed to operating temperature.
6. Return SCV levers to neutral.
7. Adjust flow control knobs to original setting.
8. Remove jumper hose.

GS25068,00053CF-19-19SEP18

Open Center Hydraulics

The open center hydraulic system is a gear driven, constant flow hydraulic system. The machine incorporates a tandem hydraulic pump design. The hydraulic and steering/transmission lubrication systems are functionally separate. Both systems and the transmission utilize a common reservoir. The priority of the hydraulic circuit is the hitch, then mid-mount SCVs, and finally the rear SCVs, which are supplied by the implement pump. Steering and brakes are supplied by the steering pump and are given priority over other functions.

For additional information on operating the hydraulic system functions, see the following sections:

- Hitch and Drawbar Operation
- Selective Control Valve Operation

GS25068,00018A1-19-23JUL21

Hitch and Drawbar Operation

Match Machine Power to Implement

IMPORTANT: Matching machine and implement ensures that neither becomes damaged.

Overpowering an implement causes damage. Attaching an implement that requires more horsepower than the machine can produce damages the machine.

See your implement operator's manual for minimum and maximum power requirements before attaching implement to machine.

DP51502.0002A66-19-02FEB17

Rear Hitch Controls

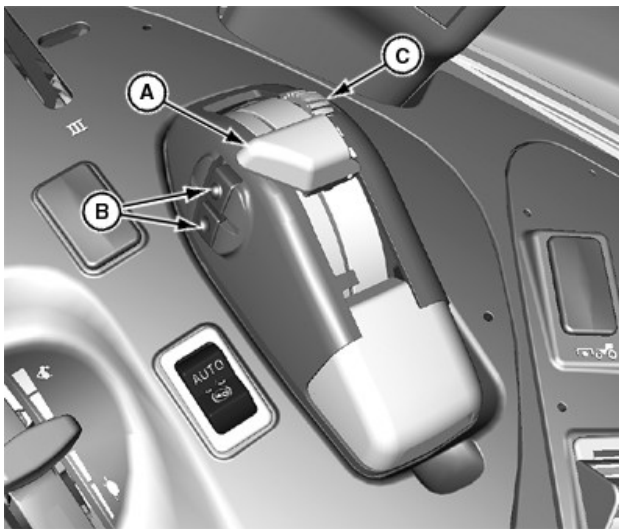

Rear Hitch Control

LV22023—UN—09JUN14



Rear Hitch Fender Switch

RXA0181088—UN—28APR21

- A—Position Lever
- B—Quick Raise/Lower Buttons
- C—Position Lever Stop
- D—Rear Hitch Fender Switch

MP60050.0000B21-19-08JUN21

Rear Hitch Components

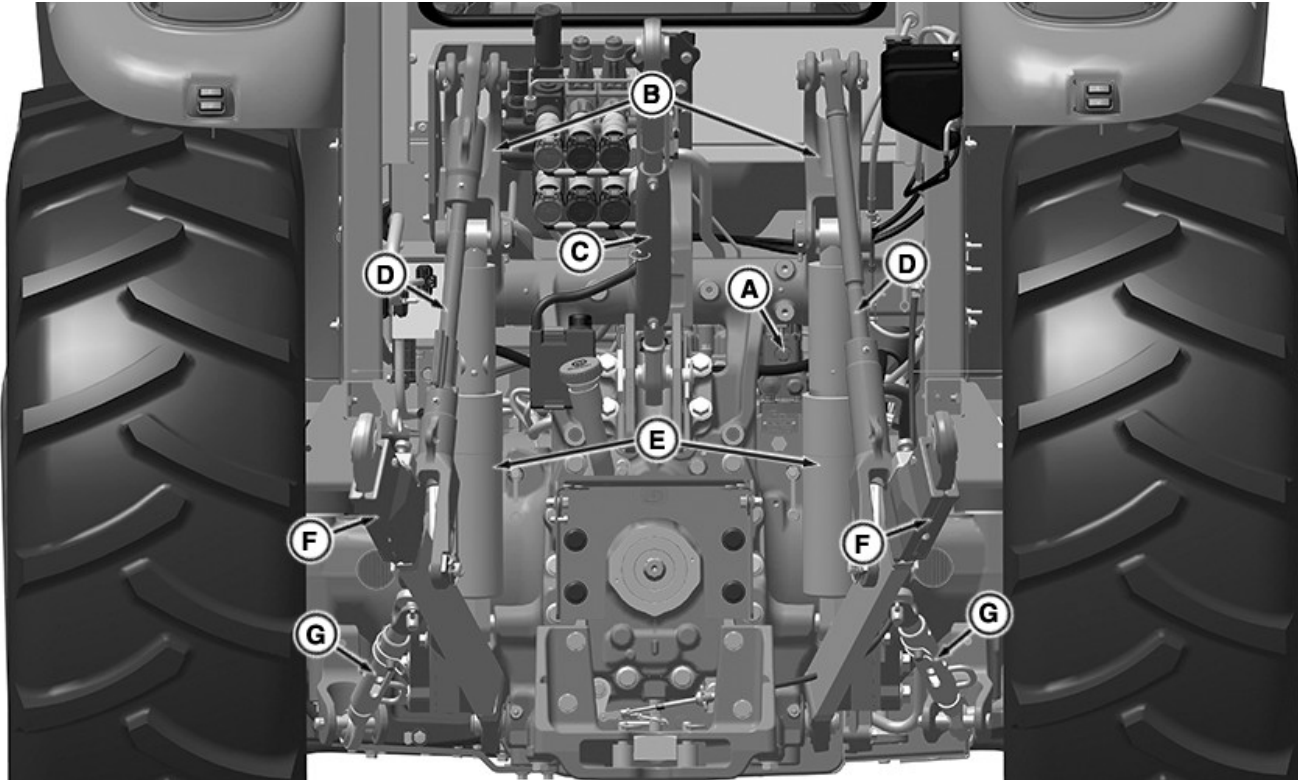

RXA0158453—UN—24MAR17

A—Hitch Valve
B—Lift Arm (2)
C—Center Link
D—Lift Link (2)

E—Hitch Cylinder (2)
F—Draft Link (2)
G—Sway Bar (2)

MP60050,0000B22-19-08JUN21

Operate Electrohydraulic Position Control

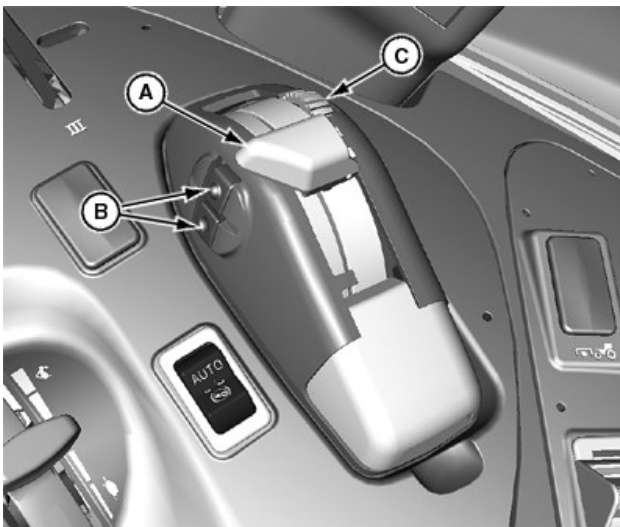

LV22023—UN—09JUN14

A—Position Lever
B—Quick Raise/Lower Buttons
C—Position Lever Stop

CAUTION: To prevent possible injury, use only position lever (A) when attaching or detaching implements. Do not use quick raise/lower buttons (B).

IMPORTANT: Draft control setting automatically influences actual hitch position. For independent position control, rotate draft knob fully counterclockwise. (See Operate Electrohydraulic Draft Control in this section.)

IMPORTANT: If the rear hitch position lever (A) is moved with the engine off, then the hitch is out of sync with the lever and does not function correctly. After starting machine, cycle the rear hitch position lever to the fully raised position and hold for 3 seconds, then to fully lowered position. The rear hitch position is resynced with the rear hitch position lever allowing operator to regain control of the rear hitch.

NOTE: Engine must be running for hitch controls to work.

Rear hitch position lever (A) controls raise or lower movement of 3-point hitch-mounted implement and ground depth penetration. Pull lever rearward to raise; push lever forward to lower.

Adjust Position Control Depth Stop:

- Push down and rotate position lever stop (C) until stop sets to desired working depth. After raising hitch, implement returns to set depth when hitch position lever (A) is pushed forward (lowered) to contact stop.

A few minutes of implement operation are required to determine the best depth. Set desired depth with position lever stop (C). Hitch returns implement to previous above- or below-ground depth.

To lower hitch below the preset depth stop, lift position lever (A) and push forward past stop.

Electrohydraulic Depth Control (level, in-ground, on-ground, and non-ground engaged situations):

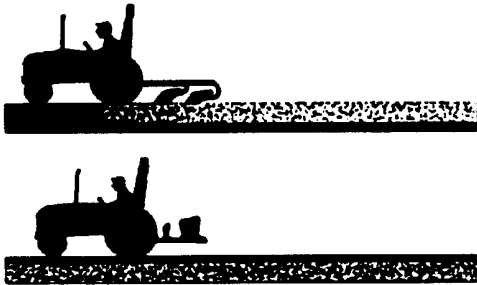

Depth Control

LV09233—UN—26JUL04

- Position lever (A) at desired depth.

Float Control (uneven, ride on-ground contour situations):



Float Control

LV9457—UN—26JUL04

- Position lever (A) fully forward and rotate draft knob fully counterclockwise.

NOTE: Ensure that implement skids or height gauge wheels are set correctly to carry full implement weight. Ensure that hitch draft link arms are adjusted for any required lateral float.

Height at Turn (end of field turn-around situations):

- Position lever (A) rearward until implement is out of ground.

NOTE: Set hitch height with the limit knob. (See Operate Electrohydraulic Height Limit Control in this section.)

Quick Raise at Turn (end of field turn around situations):

- Press and hold the top raise button of the quick raise/lower buttons (B) until hitch implement is not engaged in or on ground, but not fully raised.

NOTE: Set hitch height limit with the limit knob.

Implement Transport (load and non-load sense usage):

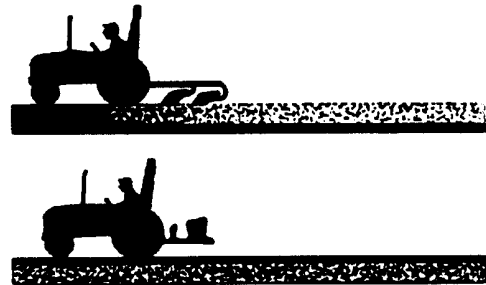

Implement Transport

LV09233—UN—26JUL04

- Position lever (A) fully rearward. Ensure that lever is in transport lock position (lever flipped over latch at the padlock symbol).

NOTE: Quick raise/lower buttons are disabled when the position lever (A) is in transport lock position. Hitch rises to transport lock position when machine is started.

MP60050,0000ACB-19-28APR21

Operate Electrohydraulic Draft Control

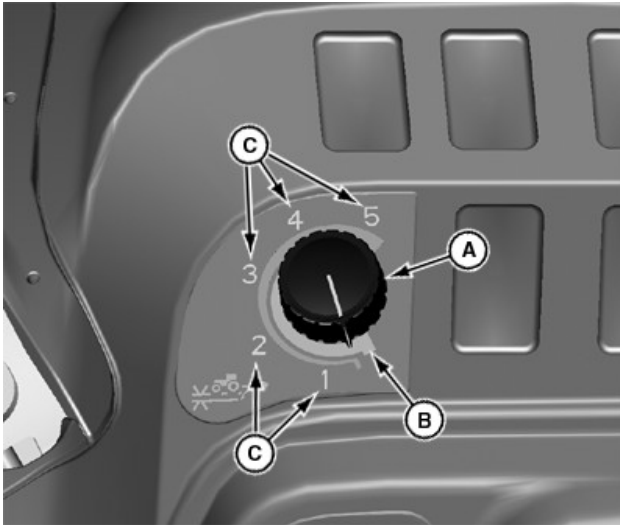

LV22018—UN—09JUN14

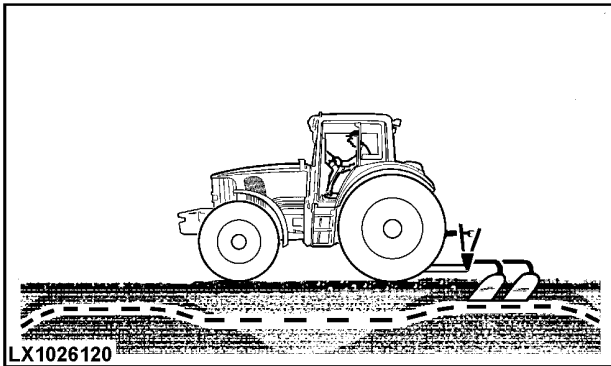

LX1026120—UN—10MAY01

Middle Draft Control Setting

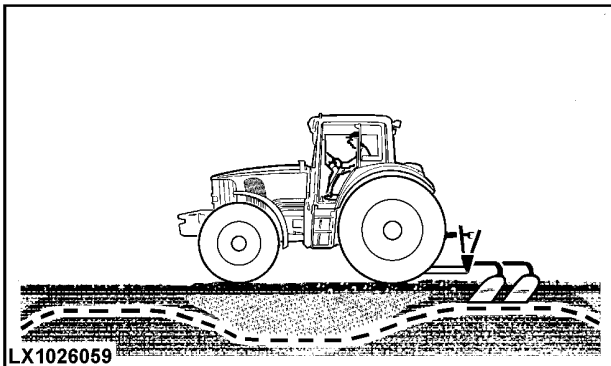

LX1026059—UN—18MAY01

High Draft Control Setting

- A—Load/Depth (Draft) Knob
- B—Position Control Detent
- C—Draft Control Setting

Rear hitch load/depth (draft) knob (A) controls 3-point hitch-mounted implement ground penetration response to varying soil conditions.

Electrohydraulic Hitch Draft Control:

1. Turn load/depth (draft) knob to one of five draft

control settings (C), to control depth and load, depending on implement and field or soil conditions:

2. Turn counterclockwise to reduce draft response.
3. Turn clockwise to increase draft response.

With the control turned to a higher number, the implement is raised as resistance (soil density) increases and lowered as resistance decreases; typical settings are:

Implement	Draft Control Setting
Integral Ripper/Subsoiler	1—3
Integral Chisel Plow	2—4
Semi-Integral Moldboard Plow	2—4
Integral Moldboard Plow	3—5
Integral Field Cultivator or Box Blade Scraper	4—5

MP60050,0000A0E-19-29JUL21

Operate Electrohydraulic Rate-of-Drop Control

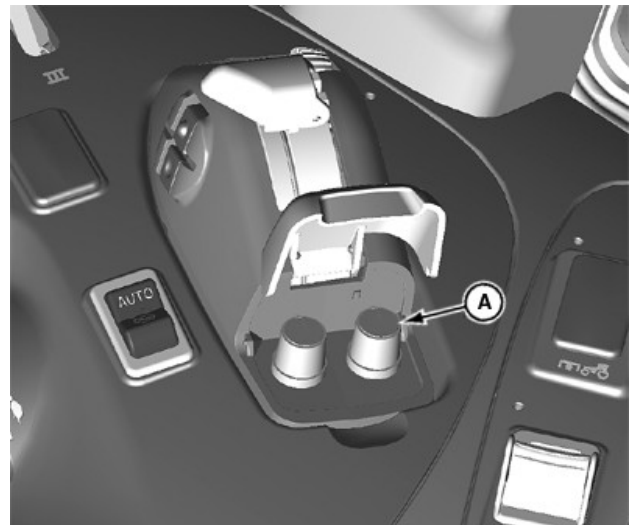

LV22019—UN—09JUN14

A—Rate-of-Drop Control

CAUTION: To avoid injury from hitch movement, only adjust rate of drop from operator's seat.

IMPORTANT: Ideal minimal implement rate of drop from fully raised to fully lowered is 2 seconds. Rate-of-drop is directly related to implement weight; therefore select a rate slow enough to prevent damage.

Electrohydraulic Rate-of-Drop Control:

- For faster rate-of-drop, rotate rate-of-drop control (A) to right (clockwise).

- For slower rate-of-drop, rotate rate-of-drop control (A) to left (counterclockwise).

MP60050,0000A0F-19-16FEB21

Operate Electrohydraulic Height Limit Control

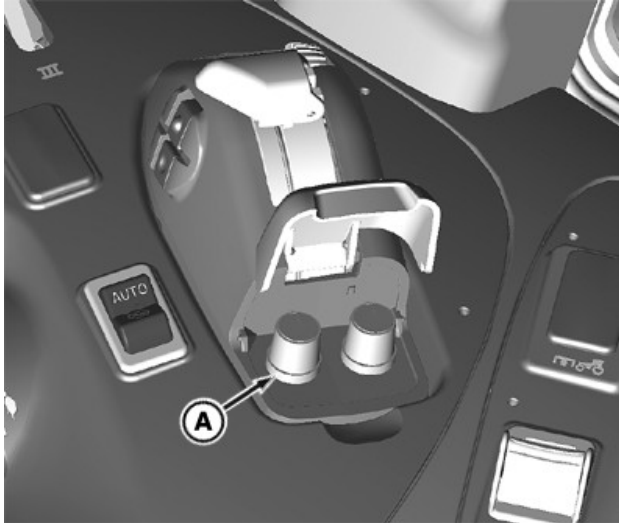

RXA0181057—UN—17FEB21

A—Height Limit Knob

The height to which an implement is raised can be limited with the height limit knob (A).

Electrohydraulic Height Limit Control:

- For minimum height, rotate height limit knob (A) fully left (counterclockwise).
- For maximum height, rotate height limit knob (A) fully right (clockwise).

MP60050,0000A3E-19-25FEB21

Operate Electrohydraulic Hitch Fender Switch

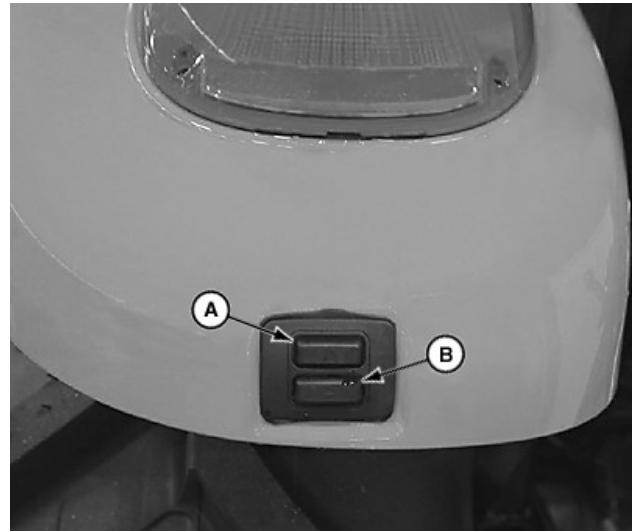

LV14566—UN—04AUG11

A—External Raise Switch
B—External Lower Switch

CAUTION: Put machine in park before using fender switches. Implement moves when fender switches are used. Stay clear of interference points during operation.

NOTE: When remote hitch switches are pressed, the hitch moves slowly but increases speed the longer hitch switch is held.

1. Hitch is raised when top external raise switch (A) is held.
2. Hitch is lowered when bottom external lower switch (B) is held.
3. Once external position control switch is activated, the hitch does not respond to movements of the position lever.

To reactivate the lever, place lever at a position that corresponds with hitch position and then actuate quick raise/lower buttons.

MP60050,0000A3F-19-29JUL21

Rear Hitch Menu

NOTE: For additional navigation information, see *Basic Menu Navigation in the Displays, Software, and Electronics Operation* section.



Rear Hitch Menu

RXA0152936—UN—21JUL16

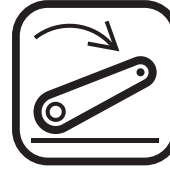

Drop Rate Selection

RXA0152939—UN—29JUL16

1. Locate the rear hitch menu.



Load Depth Selection

RXA0152937—UN—21JUL16



Raise Rate Selection

RXA0152940—UN—21JUL16

2. Select and change the desired settings as needed. See the relevant topic in this section for additional details on settings.

NOTE: Load depth, upper limit, and drop rate settings are changed by dedicated controls. Raise rate setting is changed by navigation dial.

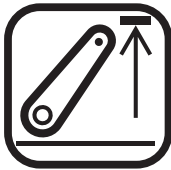

Upper Limit Selection

RXA0152938—UN—21JUL16

Selection	Range	Hitch Response
Load Depth	Position Control 0.0 Depth Control 1.0—5.0	Position control is for implements with gauge wheels. Higher values provide more/faster draft response.
Upper Limit	10—100	Higher values make the hitch raise higher.
Drop Rate	1.0—5.0	Higher values make the hitch drop faster.
Raise Rate	1.0—5.0	Higher values make the hitch raise faster.

GS25068,000190A-19-29JUL21

Load Depth Control



Load Depth Selection

RXA0152937—UN—21JUL16

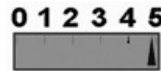

RXA0107203—UN—07APR10

High Response Causes More Depth Variation If Soil Varies

Access the load depth selection through the hitch menu. Use the draft control knob to change the desired setting as needed.

0 1 2 3 4 5

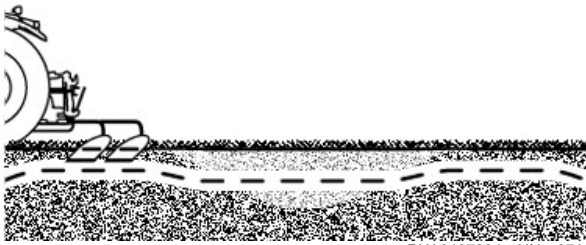

RXA0107204—UN—07APR10

Lower Response Controls Depth Better If Soil Varies

0 1 2 3 4 5

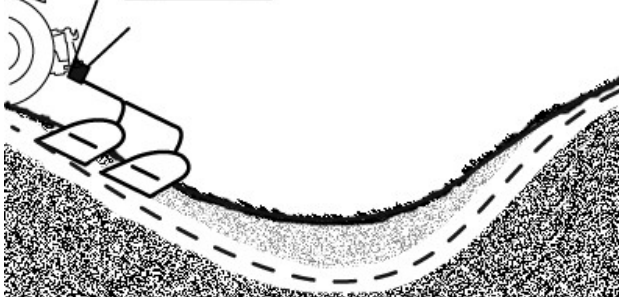

RXA0107205—UN—07APR10

Lower Response Causes More Depth Variation In Rolling Terrain

0 1 2 3 4 5

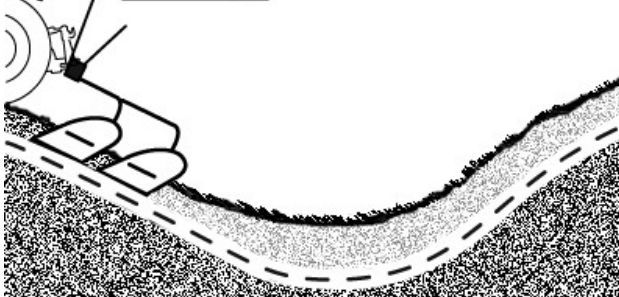

RXA0107206—UN—07APR10

Higher Response Controls Depth Better In Rolling Terrain

0 1 2 3 4 5

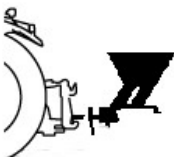

RXA0153757—UN—12SEP16

Hitch Held at Selected Position

Use draft control to maintain operating depth of tillage equipment in rolling terrain. If soil density/resistance varies, higher response setting causes more depth variation. The best setting depends on the implement type and field conditions.

Higher values provide more/faster draft response. Lower values provide less/slower draft response. Setting value to "0" is position control, which means the hitch maintains the height set by the operator.

Adjusting load/depth only changes draft responsiveness. Use hitch lever to control/change operating depth.

NOTE: Low draft response settings slow the drop rate of lighter implements. To increase the speed at which implement enters the ground, hold lever in forward detent. Hitch lowers at the drop rate selected.

Typical load/depth settings:

Integral Field Cultivator or Box Blade Scraper	4—5
Integral Moldboard Plow	3—5
Semi-Integral Moldboard Plow	2—4
Integral Chisel Plow	2—4
Integral Ripper/Subsoiler	1—3
Implements with Gauge Wheels or Non-Ground Engaging Implements	0

GS25068,0001902-19-29JUL21

Implement Float

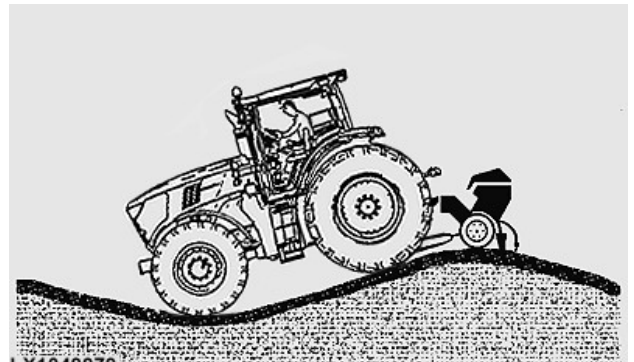

LX1049979

LX1049979—UN—18MAY11

Implement Follows Ground Contour

Implements that fully rest on gauge wheels for depth control require hitch to float and follow the ground contour.

Put hitch command lever in float position (fully forward) and set load depth control to "0".

If necessary, adjust lift links to allow lateral float. (See Adjust Lateral Float in this section.)

GS25068,00057C5-19-28SEP18

Upper Limit

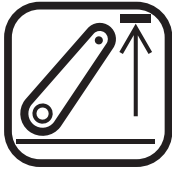

RXA0152938—UN—21JUL16
Upper Limit Selection

Access the upper limit selection through the hitch menu. Use the upper limit control to change the desired setting as needed. Higher values allow the hitch to raise higher.

Upper limit is the maximum height the hitch lifts. It is set to the operator's preference for the specific application.

Changes to upper limit are immediate. When the upper limit is the same as the hitch position, hitch follows the upper limit.

GS25068,0001903-19-29JUL21

Raise Rate



RXA0152940—UN—21JUL16
Raise Rate Selection

Access the raise rate selection through the hitch menu. Use the navigation dial to change the desired setting as needed. Higher values make the hitch raise faster.

Raise rate is the speed the hitch raises. It is set to the operator's preference for the specific application.

Changes to raise rate are immediate.

GS25068,0001909-19-29JUL21

Drop Rate

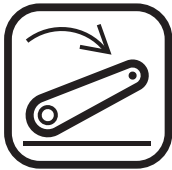

RXA0152939—UN—29JUL16
Drop Rate Selection

CAUTION: Avoid physical injury or machine damage due to excessive drop speed. Fully lowering implement must take a minimum of 2 seconds.

Access the drop rate selection through the hitch menu. Use the rate-of-drop control to change the desired setting as needed. Higher values make the hitch drop faster.

Drop rate is the speed the hitch lowers. It is set to the operator's preference for the specific application.

Changes to drop rate are immediate.

GS25068,0001904-19-29JUL21

Manually Lower Electrohydraulic Hitch

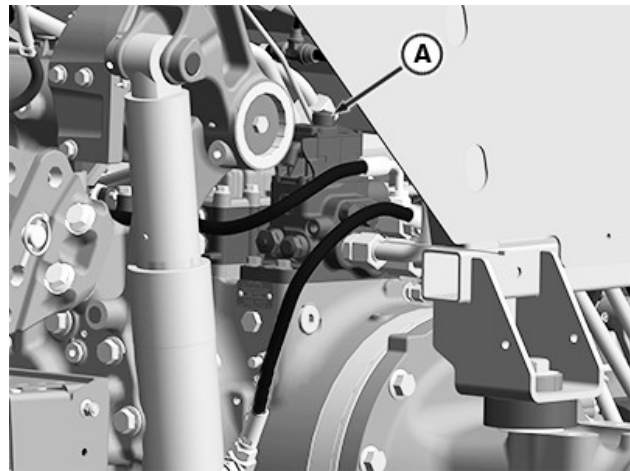

PY42048—UN—12MAY17

A—Protective Cap

CAUTION: Perform procedure from operator's station to avoid possible injury from rear hitch-mounted implements.

If engine or electrical power is not available, hitch can be lowered manually.

1. Park machine, remove key.
2. Remove protective cap (A) to access set screw.
3. Turn set screw counterclockwise to lower hitch.
4. With hitch lowered, turn the set screw clockwise and install cap.

MP60050,0000A12-19-16FEB21

Prepare Implement

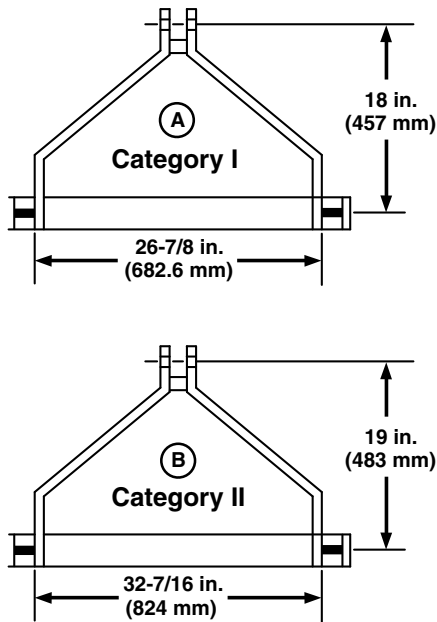

A—Category I
B—Category II

LV9639—UN—11AUG04

NOTE: See the implement operator's manual to identify implement category.

When attaching Category I implements to the machine, sway bars need adjustment to prevent binding and limiting full raise of the hitch. (See Adjust Hitch Side Sway in this section.)

Category I implements (A); hitch is narrower and shorter for smaller implements than Category II (B) implements.

Category II implements (B); hitch is wider and taller for implements larger than Category I (A) implements.

Category	Mast Height	Width Between Lower Pins	Pin Size	
			Lower	Upper
I (A)	457 mm (18 in)	682.6 mm (26-7/8 in.)	22 mm (7/8 in)	19 mm (3/4 in)
II (B)	483 mm (19 in)	824 mm (32-7/16 in.)	28 mm (1-1/8 in.)	25.4 mm (1 in)

GS25068,00053DB-19-19SEP18

Hitch Conversion - Category II to I

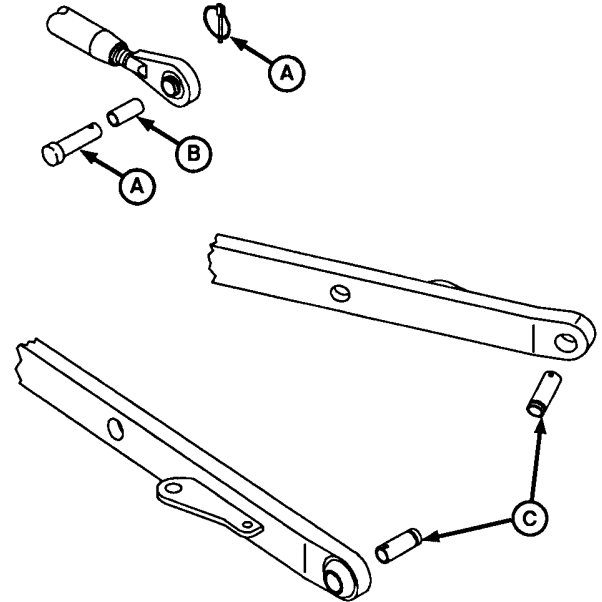

M47171A—UN—22APR94

A—Implement Pin
B—Center Link Reducing Bushing
C—Draft Link Reducing Bushing

Center link end and draft link ends are sized for Category II implement attaching pins.

To use Category I implements, convert the Category II hitch:

- Insert center link reducing bushing (B) in the center link end.
- Use smaller implement pin (A) through the implement mast.
- Add draft link reducing bushing (C) to end of draft links.

See your John Deere dealer for parts.

GS25068,00053DC-19-19SEP18

Position Center Link

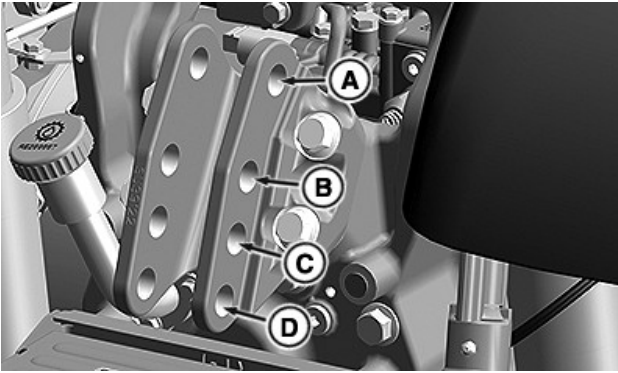

RXA0153878—UN—05DEC16

- A—Highest Position (0 degrees of tilt for category II)
- B—Second Position (10 degrees of tilt for category II)
- C—Third Position (15 degrees of tilt for category II)
- D—Lowest Position (10 degrees of tilt for category I)

The center link attaching bracket has holes which allow up to four different positions for attaching the center link.

If the following conditions occur, move the center link to indicated holes to correct.

Condition	Use Hole
Rear of implement rises too much when lifted.	A
Rear of implement drags the ground.	B or C
Category I mast height 457 mm (18 in) implement being used.	C or D
Category II mast height 483 mm (19 in) implement being used.	A, B, or C

NOTE: The implement weight which can be lifted is reduced slightly with center link attachment in lower holes C and D.

GS25068,00053DD-19-19SEP18

Adjust Lateral Float

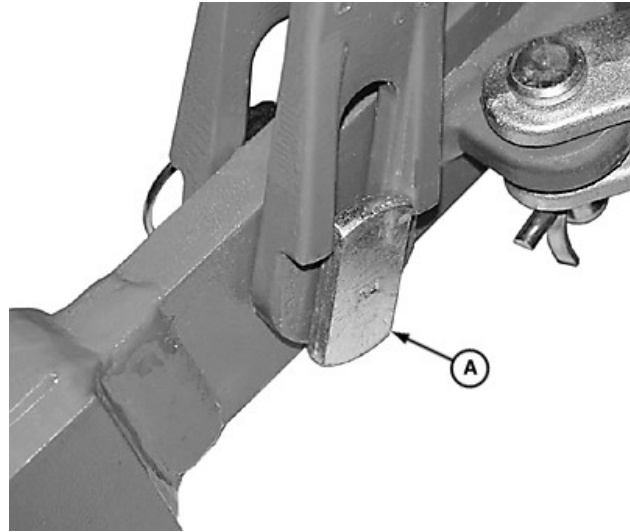

LV14581—UN—05AUG11

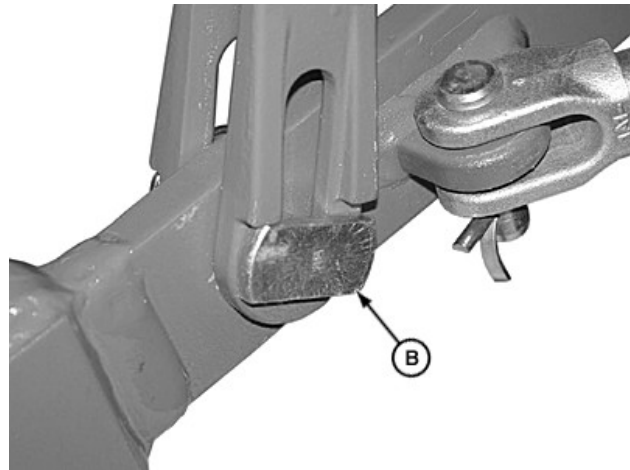

LV14583—UN—10AUG11

- A—Pin in Float Position (Vertical)
- B—Pin in Fixed Position (Horizontal)

- **Float Position (A):** Ground following implements (cultivator or mower), use ground gauging skids or wheels to rise/lower slightly or twist as implement follows the ground contour.
- **Fixed Position (B):** Ground engaging implements (plows, rippers, disk) require fixed ground depth and alignment with machine, no relative twisting.

MP60050,0000A40-19-25FEB21

Attach Implement to Rear Hitch - Ball End

CAUTION: Hitch movement can cause injury or death.

To prevent unexpected movement of rear hitch, set load depth to position control (setting "0") before attaching implement to hitch.

IMPORTANT: Ensure center link and lift link adjustments do NOT cause implement contact with fenders.

NOTE: Engine must be running for 3-point hitch control to work.

Electrohydraulic Position Control Lever

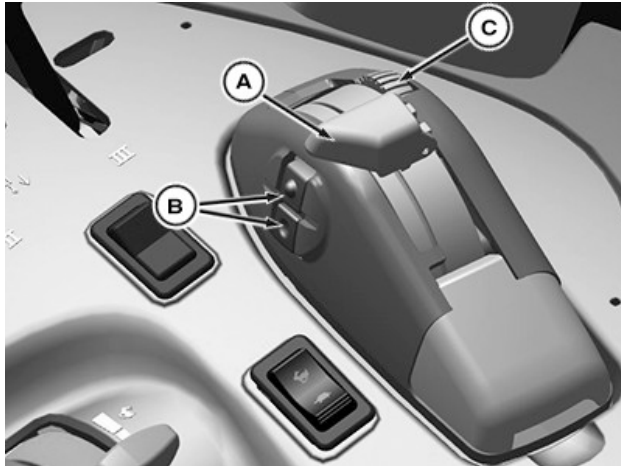

APY84608—UN—20APR23

A—Position Control Lever
B—Quick Raise/Lower Buttons
C—Position Control Lever Stop

1. Back machine up to implement to be attached. Engine must be running to operate the rear hitch.
2. Use position control lever (A) to raise or lower draft links near the attachment points. Do NOT use rear quick raise/lower buttons (B).
3. Set desired depth with the position control lever stop (B).
4. Be sure that drawbar does not interfere. If necessary, move the drawbar to fully retracted position or remove it. Check for any other potential interference.

Telescopic Draft Links

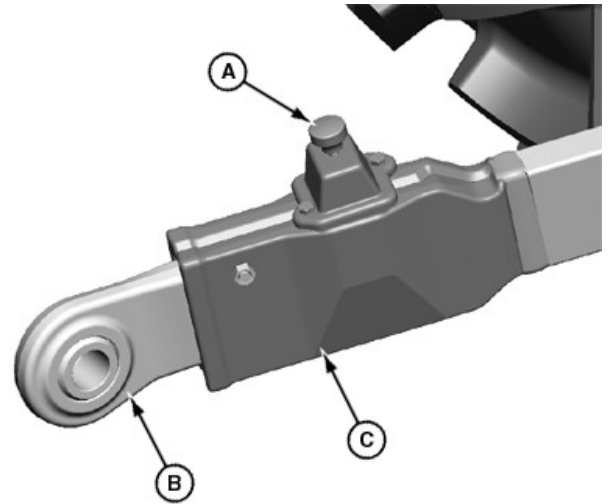

LV22036—UN—09JUN14

Heavy-Duty Draft Link

A—Button or Lock Pin
B—Draft Link End
C—Draft Arm

1. Move button or lock pin (A) toward center of machine and pull out draft link end (B). Slip draft link end over the implement hitch pin. Retain with a quick-lock pin. Repeat on the other side.
2. Raise or lower draft arms (C) to align draft link ends (B) with implement, slowly back up the machine to lock ends in place.
3. Back machine up to implement so hitch points align. Place transmission in park and stop engine.
4. Slip draft link ends (B) over the implement hitch pins and retain with quick-lock pins.

Center Link

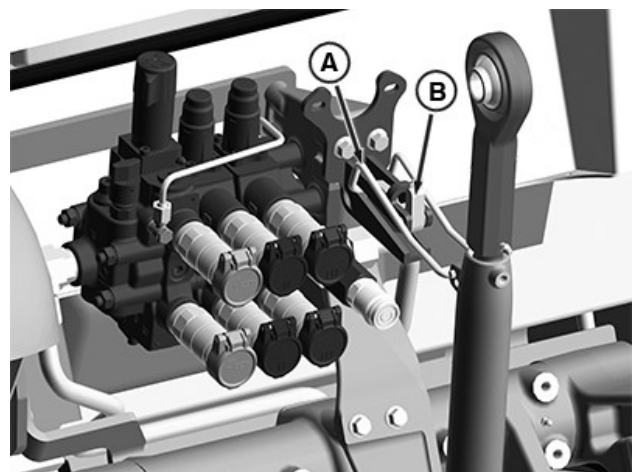

PY42051—UN—12MAY17

A—Center Link Locking Clip
B—Release Tab

1. Pull release tab (B) back and remove center link

locking clip (A) to release center link from the transport hook.

2. Attach center link to implement top mast. Use appropriate SCV to extend hydraulic center link if equipped.

Adjust and Check Clearance

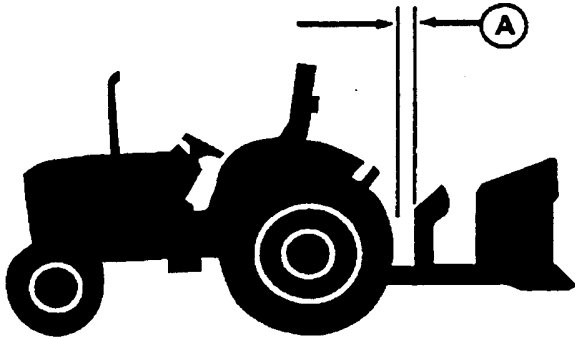

M47177—UN—31JAN92

A—Clearance

IMPORTANT: Whenever an implement, quick coupler, or attachment is connected to the hitch, check full range of operation for interference, binding, or PTO separation.

When large diameter rear tires are installed, a quick coupler or similar device is required to provide adequate implement-to-tire clearance.

1. Adjust center link and lift links as necessary. (See Level Hitch in this section.)
2. Adjust sway as necessary. (See Adjust Hitch Side Sway in this section.)
3. Start engine.
4. Slowly raise and lower implement with hitch fender switch or position control lever.
5. Watch for interference points and adjust hitch setting as required.
6. Check for adequate clearance (A) between outside diameter of the tire and implement with hitch in raised position.

MP60050,0000ACC-19-02MAY23

Level Hitch - Ball End

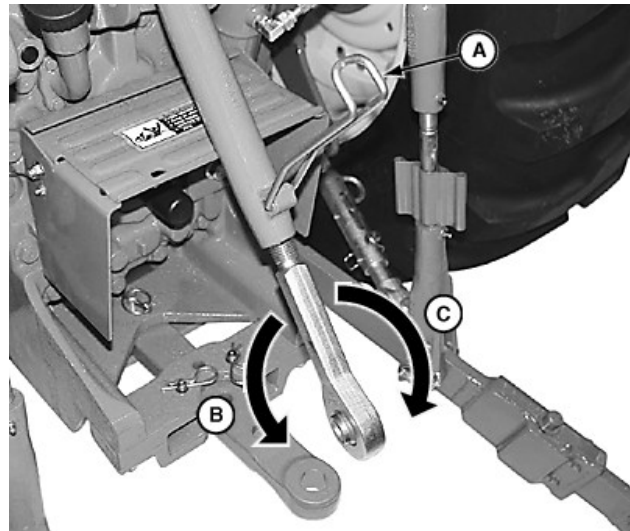

LV14578—UN—05AUG11

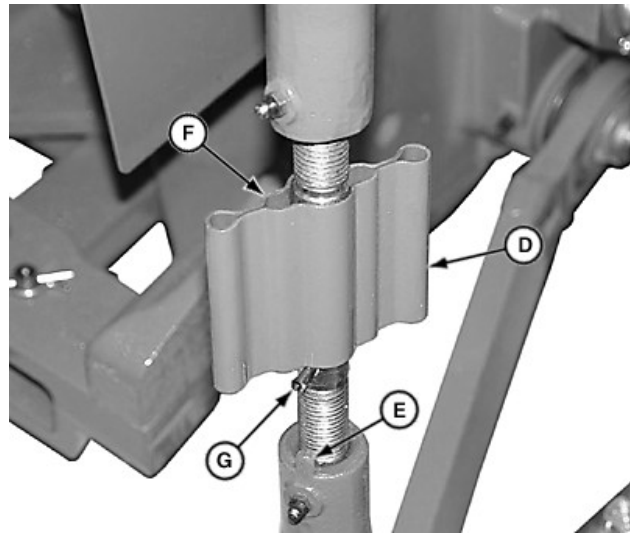

LV14579—UN—05AUG11

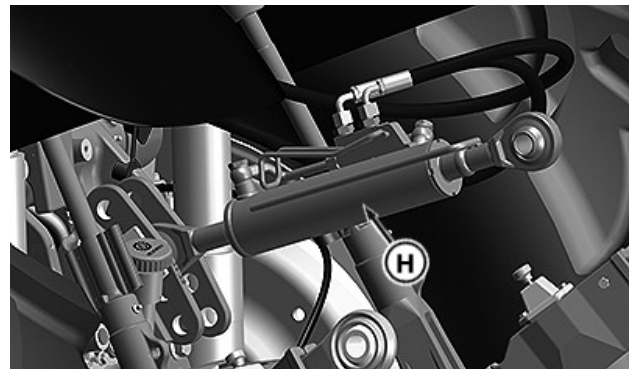

RXA0153759—UN—12SEP16

- A—Locking Clip
- B—Center Link Counterclockwise Rotation
- C—Center Link Clockwise Rotation
- D—Locking Handle
- E—Locking Tab
- F—Slot
- G—Roll Pin
- H—Hydraulic Center Link

IMPORTANT: Do NOT attempt to overextend the center link beyond limits of locking clip or lift links past the stop indicators (missing thread). Link body threads could be damaged.

Manual Center Link Adjustment:

1. Lower implement to ground and adjust center link to level implement front-to-rear.

NOTE: Maximum adjustment range of the center link can only be obtained if the ends are positioned equally within the body when attached to an implement.

2. Unlatch locking clip (A). Rotate link body:
 - a. Clockwise (C) to lengthen.
 - b. Counterclockwise (B) to shorten.
3. Latch locking clip.

Lift Link Adjustment:

1. Adjust lift link to level implement side-to-side. Lift locking handle (D) to clear locking tab (E). Keep slot (F) engaged on roll pin (G) and turn locking handle (D):
 - a. Clockwise to raise the draft link.
 - b. Counterclockwise to lower the draft link.
2. When adjustment is complete, align slot (F) with locking tab (E), and lower to lock in place and prevent change of adjustment during operation.

Hydraulic Center Link Adjustment:

1. Engage implement in application.
2. Use appropriate SCV to extend or retract the cylinder of hydraulic center link (H) to level implement front-to-rear.

MP60050,0000ACD-19-28APR21

Attach Implement to Rear Hitch - Hook-End

CAUTION: Hitch movement can cause injury or death.

To prevent unexpected movement of rear hitch, set load depth to position control (setting "0") before attaching implement to hitch.

IMPORTANT: Ensure center link and lift link adjustments DO NOT cause implement contact with fenders.

NOTE: Engine must be running for 3-point hitch control to work.

Electrohydraulic Position Control Lever

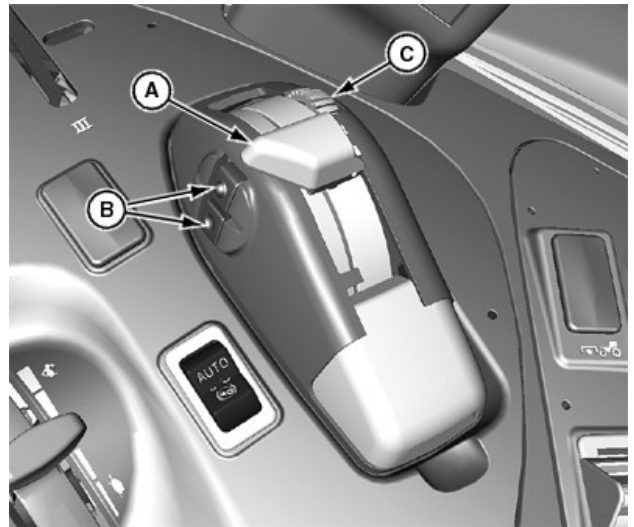

LV22023—UN—09JUN14

A—Position Control Lever
 B—Quick Raise/Lower Buttons
 C—Position Control Lever Stop

1. Back machine up to implement to be attached. Engine must be running to operate the rear hitch.
2. Use position control lever (A) to raise or lower draft links near the attachment points. Do NOT use rear quick raise/lower buttons (B).
3. Set desired depth with the position control lever stop (C).
4. Be sure that drawbar does not interfere. If necessary, move the drawbar to fully retracted position or remove it. Check for any other potential interference.

Hook-End Draft Links

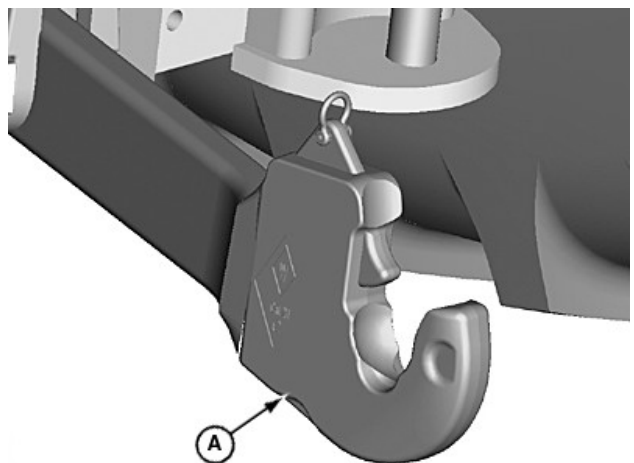

A—Hook-Type Draft Link

LV15845—UN—29JUN12

⚠ CAUTION: When implements with asymmetrical load (e.g. side-mounted mowing unit) are attached, or when driving through high-growing bushes and trees (e.g. when working in the forest), the draft links must be secured against opening accidentally.

NOTE: The coupler hooks can be locked in their "open" position by pulling on lever and rotating 90 degrees.

To close the coupler hook again, pull the lever up at an angle and rotate.

Hook-type draft links (A) are intended for Category I, Category II and Category 3N implements. Implements can be attached to and removed from the draft links without the driver having to leave the seat.

Draft Link Release Cable

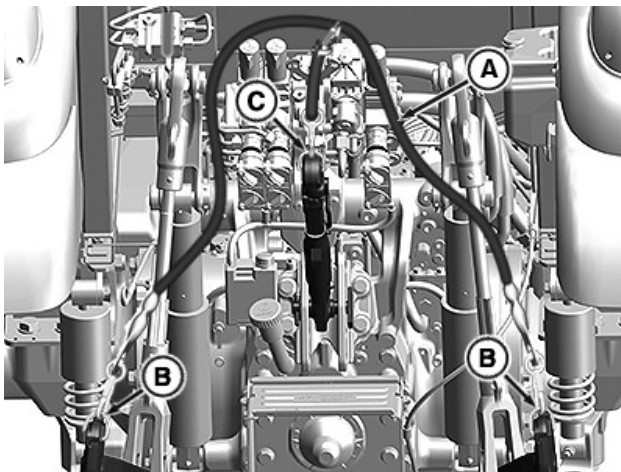

PY30462—UN—10MAR17

Draft Link Release Cable

- A—Release Cable
- B—Draft Link Ends
- C—Center Link

Hook-type draft links (B and C) can be released from the operator's position by pulling on cable (A). When cable (A) is released, hook-end draft links return to closed position.

Attaching Implement



RXA0156170—UN—13DEC16

IMPORTANT: Make certain that implement is correctly locked to coupler hooks.

1. With draft links lowered, reverse machine until the coupler hooks are below the implement hitch pins.
2. Slowly raise draft links until pins are engaged in coupler hooks and locked into position.
3. Adjust center link to the required length and attach to top attaching point of implement mast.

Draft Link Hook Lock

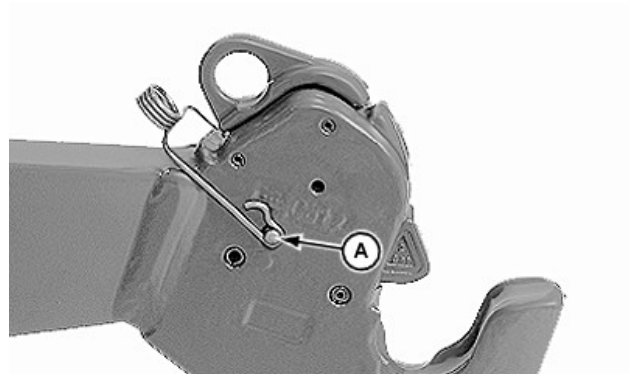

LV16212—UN—22OCT12

A—Draft Link Locking Pin

⚠ CAUTION: Use draft link locking pins on applications where implement could be forced up and open unintentionally. Examples are driving through high-growing bushes, trees, or implements with asymmetrical load, such as a side-mounted mower.

1. Lower rear hitch below the implement connection points.
2. Position coupler ends of lift arms below the implement link pins and slowly raise hitch until coupler ends lock on the pins.
3. Insert draft link locking pins (A) in both coupler hooks. See your John Deere dealer for locking pins.

Center Link

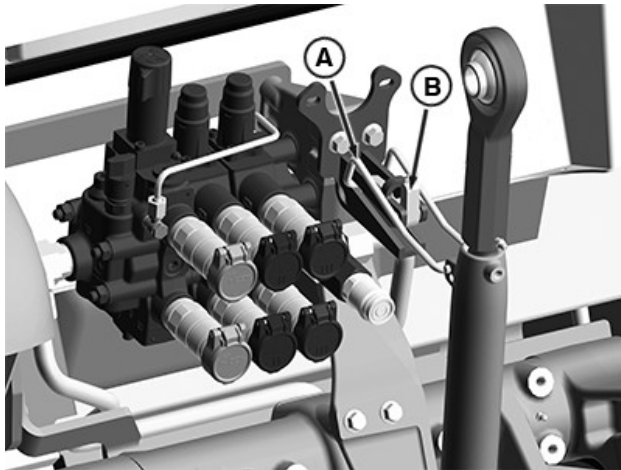

A—Center Link Locking Clip
B—Release Tab

PY42051—UN—12MAY17

1. Pull release tab (B) back and remove center link locking clip (A) to release center link from the transport hook.
2. Attach center link to implement top mast. Use appropriate SCV to extend hydraulic center link if equipped.

Adjust and Check Clearance

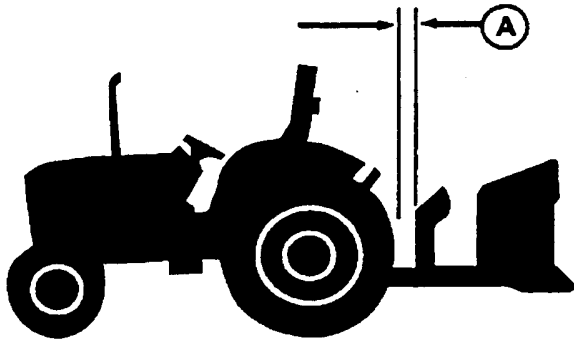

A—Clearance

M47177—UN—31JAN92

IMPORTANT: Whenever an implement, quick coupler, or attachment is connected to the hitch, check full range of operation for interference, binding, or PTO separation.

When large diameter rear tires are installed, a quick coupler or similar device is required to provide adequate implement-to-tire clearance.

1. Adjust center link and lift links as necessary. (See Level Hitch in this section.)
2. Adjust sway as necessary. (See Adjust Hitch Side Sway in this section.)
3. Start engine.

4. Slowly raise and lower implement with hitch fender switch or position control lever.
5. Watch for interference points and adjust hitch setting as required.
6. Check for adequate clearance (A) between outside diameter of the tire and implement with hitch in raised position.

MP60050,0000ACE-19-28APR21

Level Hitch - Hook-End

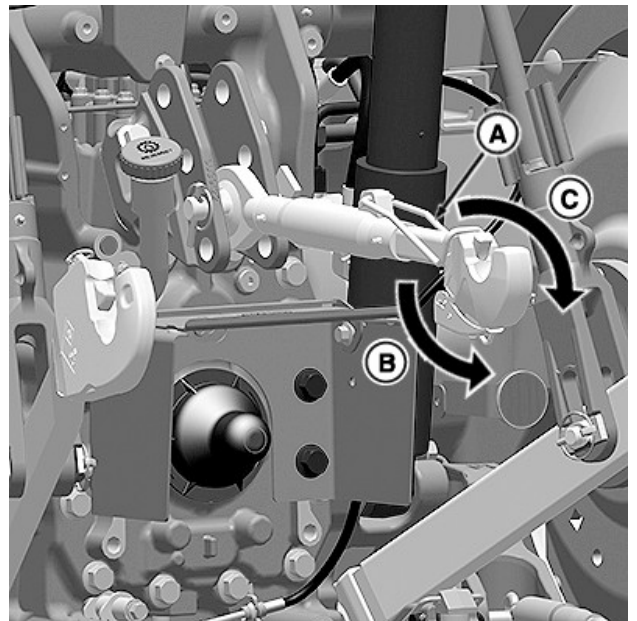

RXA0155541—UN—08NOV16

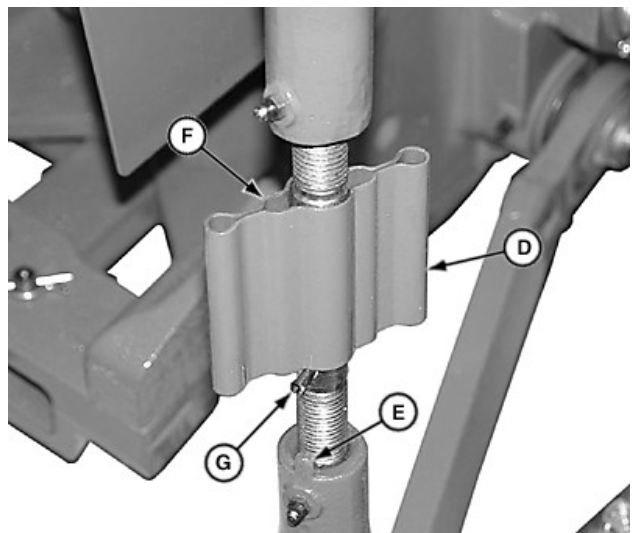

LV14579—UN—05AUG11

of hydraulic center link (H) to level implement front-to-rear.

GS25068,000029D-19-07OCT19

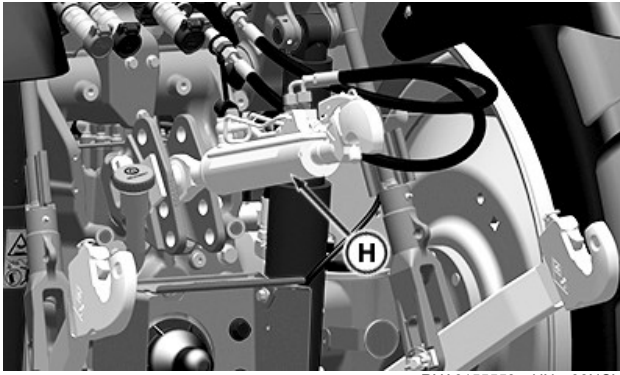

Hydraulic Center Link

RXA0155553—UN—08NOV16

Adjust Hitch Side Sway

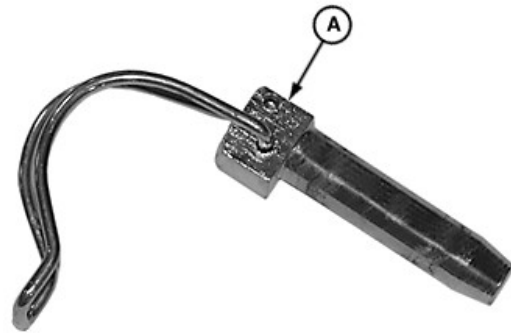

- A—Locking Clip
- B—Center Link Counterclockwise Rotation
- C—Center Link Clockwise Rotation
- D—Locking Handle
- E—Locking Tab
- F—Slot
- G—Roll Pin
- H—Hydraulic Center Link

IMPORTANT: Do NOT attempt to overextend the center link beyond limits of locking clip or lift links past the stop indicators (missing thread). Link body threads could be damaged.

Manual Center Link Adjustment:

1. Lower implement to ground and adjust center link to level implement front-to-rear.

NOTE: Maximum adjustment range of the center link can only be obtained if the ends are positioned equally within the body when attached to an implement.

2. Unlatch locking clip (A). Rotate link body:
 - a. Clockwise (C) to lengthen.
 - b. Counterclockwise (B) to shorten.
3. Latch locking clip.

Lift Link Adjustment:

1. Adjust lift link to level implement side-to-side. Lift locking handle (D) to clear locking tab (E). Keep slot (F) engaged on roll pin (G) and turn locking handle (D):
 - a. Clockwise to raise the draft link.
 - b. Counterclockwise to lower the draft link.
2. When adjustment is complete, align slot (F) with locking tab (E), and lower to lock in place and prevent change of adjustment during operation.

Hydraulic Center Link Adjustment:

1. Engage implement in application.
2. Use appropriate SCV to extend or retract the cylinder

LV14576—UN—05AUG11

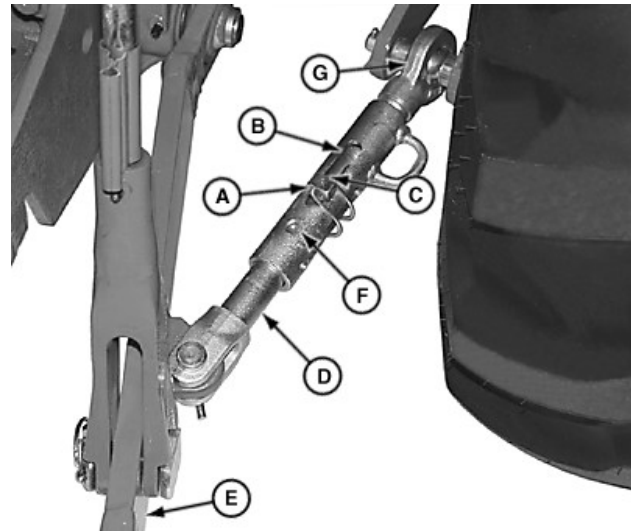

Sway Bar Pin in Sway Position

LV14575—UN—05AUG11

- A—Pin
- B—Sway Position Outer Slot
- C—Sway Position Inner Slot
- D—Inner Sliding Member
- E—Draft Link
- F—Fixed Position Holes
- G—Stabilizer

NOTE: Check implement operator's manual for instruction on whether to allow side sway.

If sway is desired, install pin (A) in the sway position outer slot (B), ensuring it goes through the inner slot (C).

If sway is not desired, move draft link (E) to desired

position. Install pin (A) in a fixed position hole (F) that lines up with one of the holes (not slot) of the inner sliding member (D).

Adjust opposite side sway bar to same position.

NOTE: Additional fixed positions are obtained by adjusting threaded end of stabilizer (G). Remove pin (A) and rotate the stabilizer to desired position. Insert pin in a fixed position hole. Missing thread on stabilizer also acts as a stop indicator.

GS25068,00053E1-19-19SEP18

Quick-Coupler

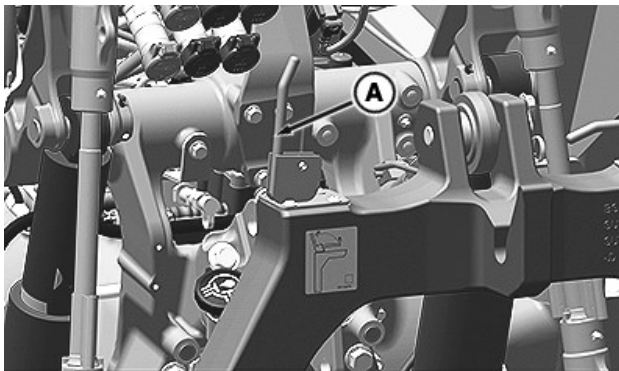

RXA0181056—UN—17FEB21

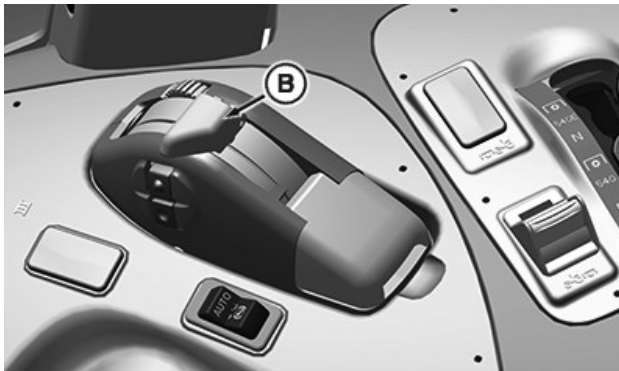

RXA0158454—UN—30MAR17

A—Coupler Latch Handle (2)
B—Electrohydraulic Position Lever

⚠ CAUTION: Avoid bodily injury or machine damage:

- Put transmission in park position and check the full range of hitch for interference, binding, or PTO separation whenever an implement is attached.
- Make sure that implement is correctly attached. Incorrect attachment can allow implement to be pulled over the machine wheel and onto the operator's station.
- Do not stand between machine and implement.

Connect Implement:

1. Pull coupler latch handles (A) up.
2. Lower hitch until quick-coupler hooks are lower than implement hitch pins.
3. Back up the machine to implement.
4. Raise hitch enough to engage implement pins in hooks.
5. Push coupler latch handles down to lock implement to quick-coupler.
6. Connect hydraulic hoses and electrical connections.

IMPORTANT: Check for implement interference. Drawbar removal may be necessary.

7. Slowly pull rear hitch electrohydraulic position lever (B) to raise implement. Lower implement to ground and adjust upper height limit control if necessary.

Disconnect Implement:

1. Pull coupler latch handles (A) up with implement raised.
2. Disconnect hydraulic hoses and electrical connections.
3. Lower implement to ground and continue lowering quick-coupler until hooks clear implement hitch pins.
4. Carefully drive the machine away from implement.

D3K5H22,00005E0-19-22APR21

Front Hitch Components

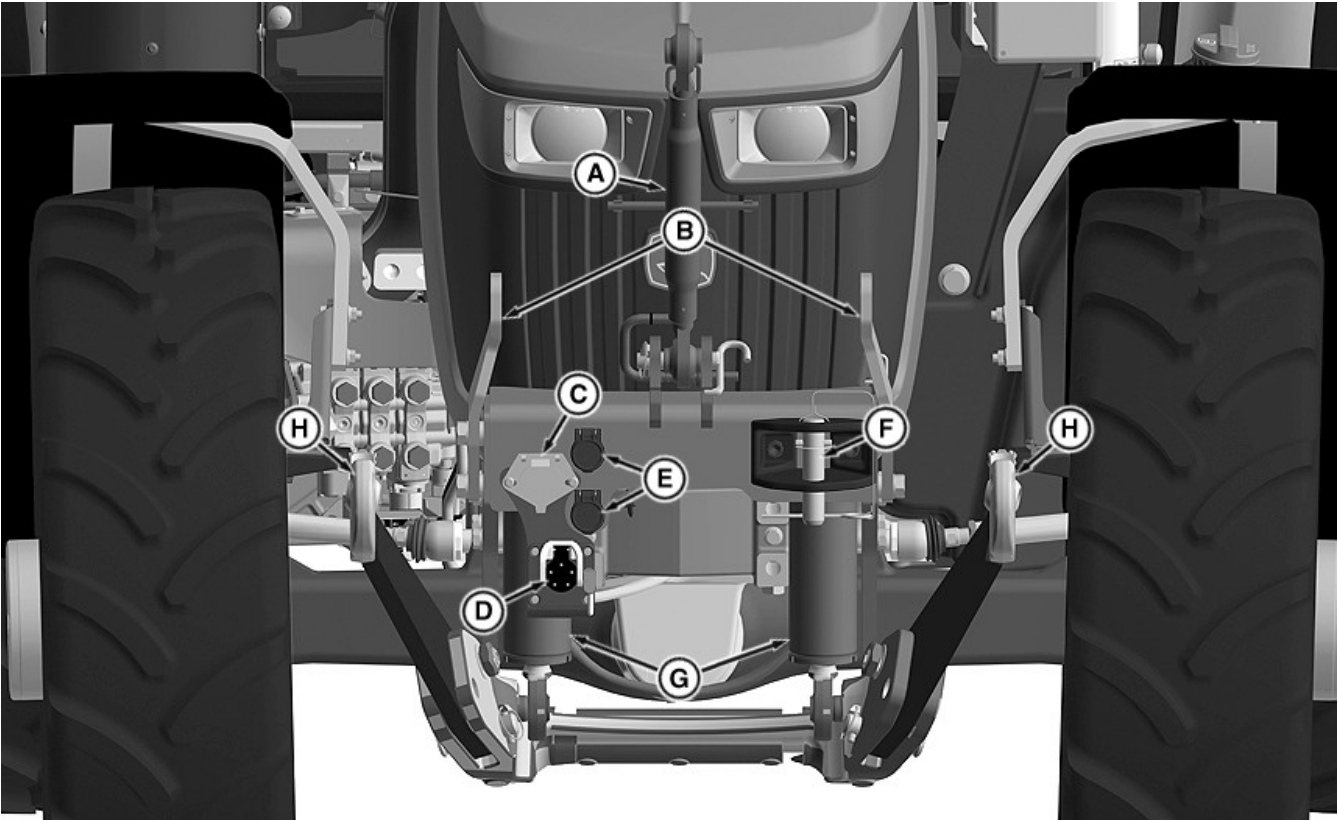

RXA0164940—UN—31OCT18

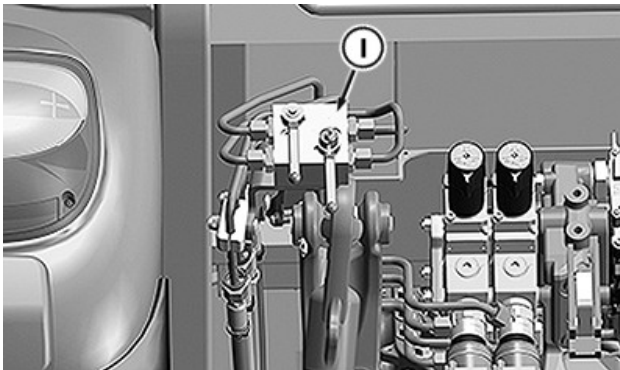

RXA0164942—UN—31OCT18

- A—Center Link
- B—Chain Hook (2)
- C—Front Implement Connector
- D—Front ISOBUS Connector
- E—Front SCV Coupler (2)
- F—Tow Pin
- G—Hitch Cylinder (2)
- H—Lift Arm (2)
- I—Diverter Valve

D3K5H22.00005E1-19-22APR21

Front Implement Connection

Draft Link Positions

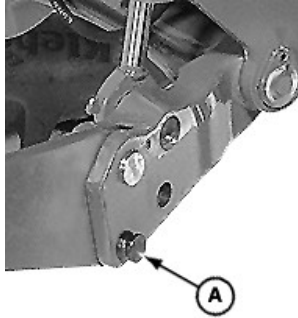

LV16176—UN—12OCT12

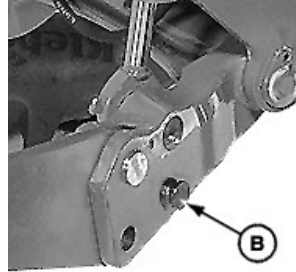

LV16177—UN—12OCT12

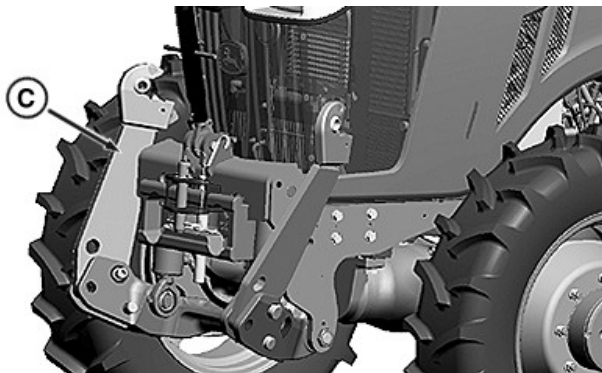

RXA0153888—UN—19SEP16

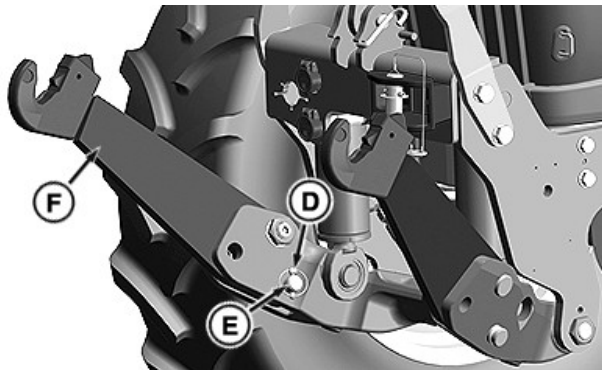

RXA0153886—UN—13SEP16

- A—Draft Link in Vertical Float Position
- B—Draft Link in Locked Position
- C—Draft Link in Transport Position
- D—Retaining Clip
- E—Draft Link Pin
- F—Draft Link

Set front draft links to vertical float position (A), locked position (B), or transport position (C).

To change setting:

1. Remove retaining clip (D) from pin (E).
2. Lift draft link (F) to relieve pressure from pin.
3. Remove pin.
4. Move draft link to desired position.

5. Reinstall pin and retaining clip.

Draft Link Hook Lock



RXA0159204—UN—10MAY17

A—Draft Link Locking Pin Hole

CAUTION: Use draft link locking pins on applications where implement could be forced up and open unintentionally. Examples are driving through high-growing bushes, trees, or using implements with asymmetrical load, such as a side-mounted mower.

1. Install front-mounted implement using SCV II. For diverter valve settings, see Front Hitch and Coupler Operation in this section.
2. Lower front hitch below the implement connection points.
3. Position coupler ends of lift arms below the implement link pins and slowly raise hitch until coupler ends lock on the pins.
4. Insert draft link locking pin into draft link locking pin hole (A) in both coupler hooks. See your John Deere dealer for locking pins.

Front Hitch Center Link

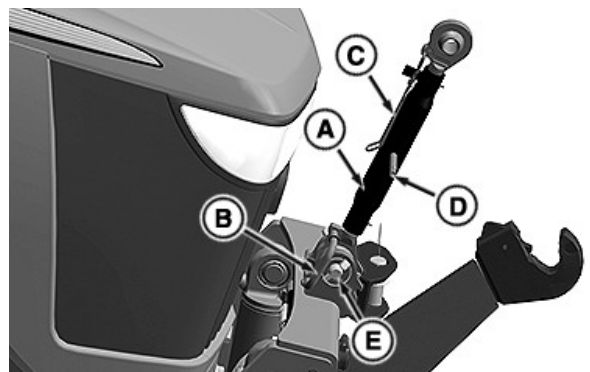

RXA0153887—UN—13SEP16

- A—Center Link
- B—Storage Handle
- C—Locking Clip
- D—Turnbuckle
- E—Pin and Clip

1. Lower implement to ground.

2. Hold center link (A) and pull on the storage handle (B).
3. Align center link with the top mast of implement.
4. To lengthen or shorten the center link, move locking clip (C) away from center link.
5. Use turnbuckle (D) to adjust length and return locking clip (C) to closed position.

NOTE: Perform additional adjustment as necessary to level implement after cycling front hitch.

6. Install implement pin through center link and retain.
7. Remove implement in reverse order.

NOTE: If front hitch center link must be removed for any reason, support center link and remove pin and clip (E).

MP60050,0000A34-19-22FEB21

- Lower - front hitch is powered down and has down-pressure.
- Float - front hitch lowers and follows the ground contour.
- Raise - front hitch lifts upward.

Rear SCV II or III lever controls the couplers on the front hitch. The function of the front couplers is the same as rear SCV II.

MP60050,0000B20-19-27JUL21

Operate Front Hitch with Rear SCV Controls

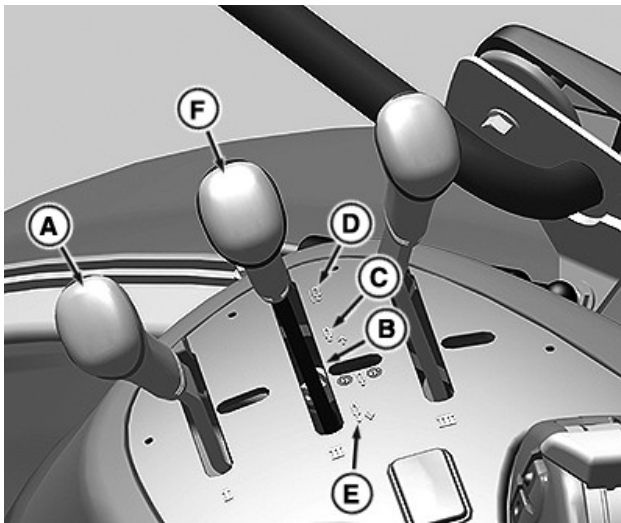

RXA0158647—UN—02MAY17

- A—Rear SCV I Lever
- B—Front Hitch Neutral Position
- C—Front Hitch Lower Position
- D—Front Hitch Float Position
- E—Front Hitch Raise Position
- F—Rear SCV II Lever

NOTE: The front hitch utilizes the SCV I (dual SCV) or SCV II (triple SCV) for oil supply and control.

To use the front hitch or the front SCV couplers, the operator must shift the diverter valve. (See Front Hitch and Coupler Operation in this section.)

Rear SCV I or II lever (A or F) controls the front hitch functions.

- Neutral - front hitch does not move.

Front Hitch and Coupler Operation

Diverter Valve Operation

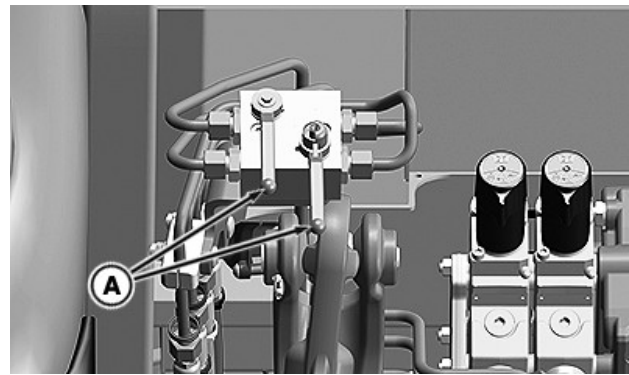

RXA0153882—UN—13SEP16

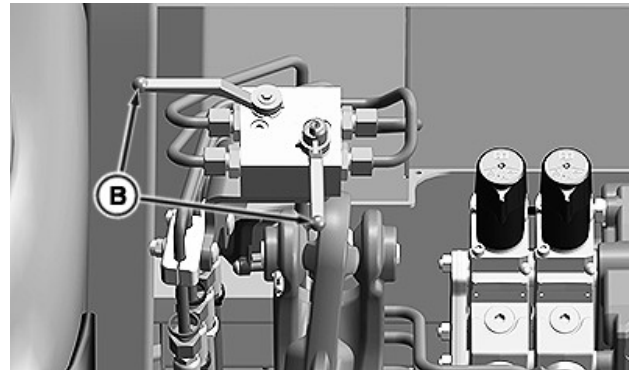

RXA0153883—UN—13SEP16

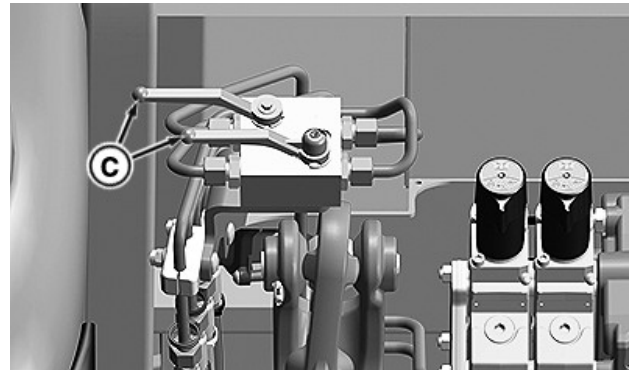

RXA0153884—UN—13SEP16

- A—Oil Flow Blocked Setting
- B—Hydraulic Raise, Gravity Lower Setting
- C—Hydraulic Raise and Lower Setting

NOTE: The SCV configuration the machine is equipped with determines which SCV levers are used to operate the front hitch and SCV. Dual SCV valves use SCV I for front hitch and SCV II for front SCV. Triple SCV valves use SCV II for front hitch and SCV III for front SCV.

CAUTION: If rear SCV I or II couplers are used for a rear implement, diverter valve must be in the oil flow blocked setting (A) to the front hitch.

IMPORTANT: When front-mounted implements with retaining chains are used, avoid damage by selecting hydraulic raise, gravity lower setting (B). Operate SCV I or II in float to allow implement to follow the ground contour.

The diverter valve is located just outside the rear window on the rear left corner of the cab and only controls front hitch oil flow. Diverter valve handles can be accessed and changed from within the machine cab. There are three settings for the diverter valve:

- Oil flow blocked setting (A). Front hitch does not move.
- Hydraulically raised, gravity lower setting (B) using weight of implement.
- Hydraulically raised and lower setting (C).

Front Hitch Operation

CAUTION: Do not attach hoses to rear SCV I or II couplers if using front hitch. Unexpected movement and undesired performance occur.

The front hitch utilizes the SCV I (dual SCV) or SCV II (triple SCV) for oil supply and control on the rear SCV assembly.

The front hitch utilizes the SCV XI for oil supply and control on the mid-mount SCV assembly.

To operate front hitch with rear SCV controls, see Operate Front Hitch with Rear SCV Controls in this section.

To operate front hitch with mid-mount SCV controls, see Mid-Mount SCV Controls and Components in the Selective Control Valve Operation section.

Front Hydraulic Couplers

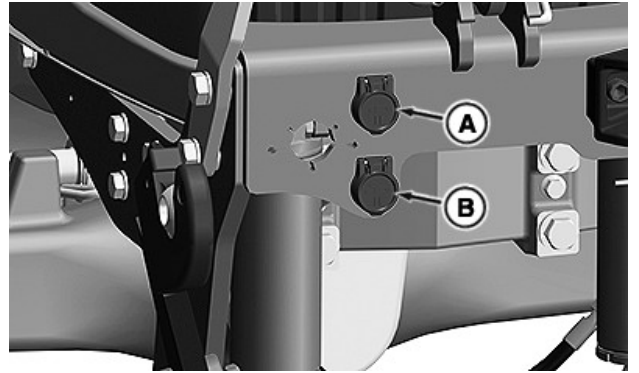

RXA0153885—UN—13SEP16

A—Retract Coupler
B—Extend Coupler

CAUTION: Do not attach hoses to rear SCV II or III couplers if using front couplers. Unexpected movement and undesired performance occur.

1. Open cover and connect hoses to retract and extend couplers (A and B) accordingly.

NOTE: Connection and disconnection are possible when ports are not under pressure. Move SCV II lever to release pressure as required.

2. Use SCV II (dual SCV) or SCV III (triple SCV) to operate front hydraulic couplers.
3. When removing, firmly pull to disconnect hoses.

MP60050.0000B24-19-27JUL21

Drawbar Settings

Adjust Drawbar Length

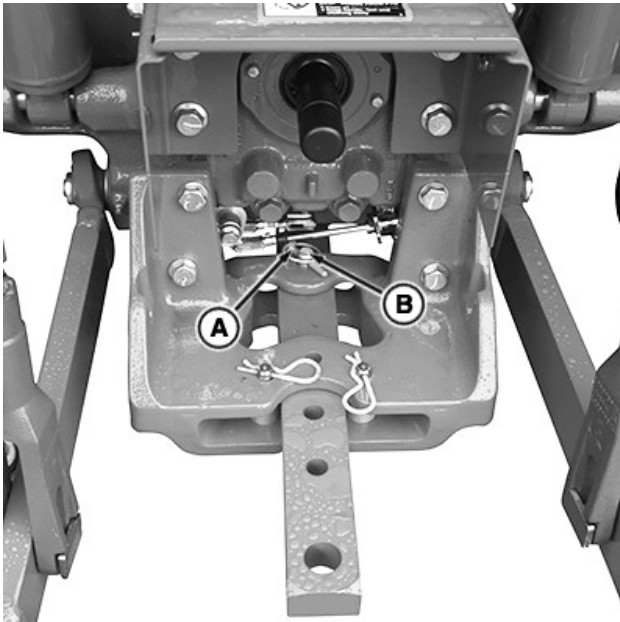

A—Retaining Pin
B—Drawbar Pin

RXA0155957—UN—05DEC16

1. Remove retaining pin (A).
2. Remove drawbar pin (B).
3. Slide drawbar to desired position.
4. Install pin (B) and insert a retaining pin (A) to lock drawbar in place.

Adjust Drawbar Offset

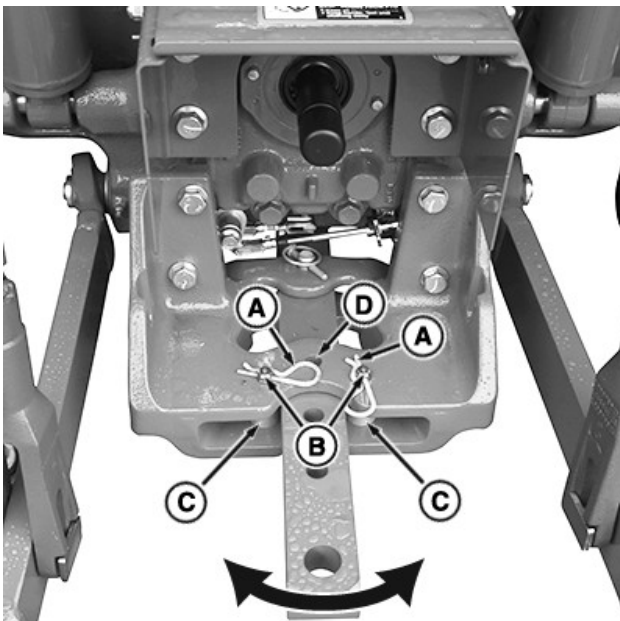

A—Retaining Pin
B—Drawbar Pin
C—Spacers (2)

RXA0155958—UN—05DEC16

D—Offset Mounting Hole

1. Remove retaining pin (A).
2. Remove pin (B) and spacers (C).
3. Offset drawbar toward left or right.
4. Install pin (B) and insert a retaining pin (A) and spacers (C) into hole (D) to hold drawbar in place.

D3K5H22.00005E2-19-22APR21

Clevis Drawbar

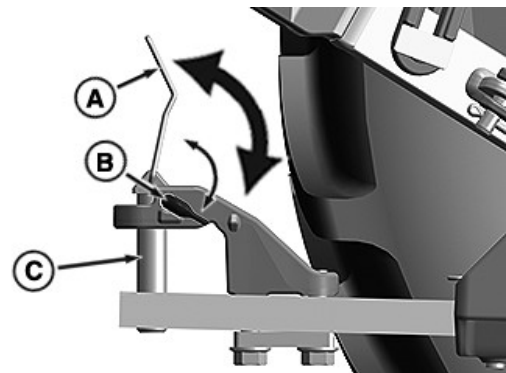

RXA0154069—UN—23SEP16

A—Handle
B—Retaining Pin
C—Implement Pin

1. Flip handle (A) to the vertical position as indicated.
2. Rotate retaining pin (B) counterclockwise while pulling upward on the handle. Implement pin (C) releases when a notch in retaining pin aligns.
3. Implement pin can be removed during connection or placed in the upper position. There are two detents on the implement pin shaft, one at the top and bottom. If the bottom detent of the implement pin is aligned with the retaining pin and locked, the pin is held up, allowing connection to the implement.

DP51502.0002A7F-19-02FEB17

Drawn Implement Connection

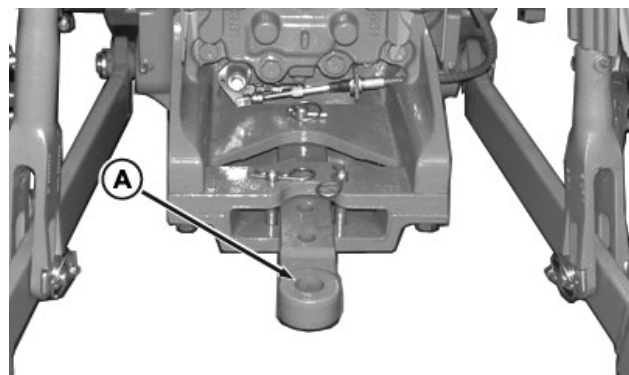

PULV004940—UN—19JUN09

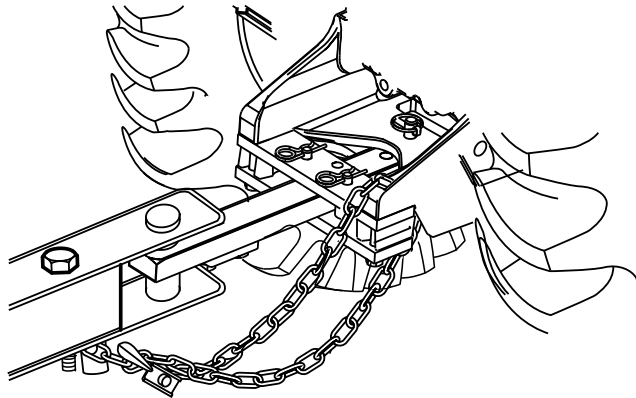

PULV000530—UN—11MAR08

Safety Chain with Drawbar Retracted

3. Use a drawbar pin that is matched for the machine and implement holes with as little free play as possible.
4. Install a retaining clip in the drawbar pin.
5. Install a safety chain from the implement to the machine.

GS25068,00053E6-19-19SEP18

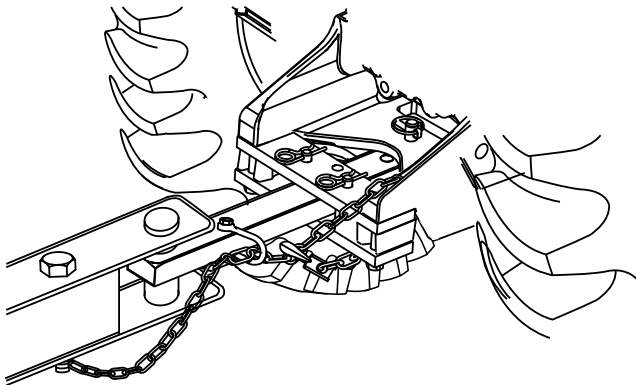

PULV000531—UN—11MAR08

Safety Chain with Drawbar Extended

A—Drawbar

CAUTION: Using smaller diameter pins reduces implement control, increases potential for pin failure, and causes excessive drawbar wear.

CAUTION: A safety chain helps control drawn equipment in case it accidentally separates from the drawbar.

Using the appropriate adapter parts, attach the chain to the drawbar support. Provide only enough slack in the chain to permit turning.

See your John Deere dealer for a chain with a strength rating equal to or greater than the gross weight of the towed machine.

IMPORTANT: Some heavy implements, such as a loaded single-axle trailer, can put excessive strain on drawbar. Speed and rough terrain increase drawbar strain. Reduce speed with heavy loads. Do not exceed maximum static vertical load on drawbar. See the Specifications section for maximum vertical drawbar load.

1. Back machine up to implement.
2. Align drawbar (A) with the implement connection point as close as possible.

Selective Control Valve Operation

Rear SCV Controls and Components

Rear SCV Controls

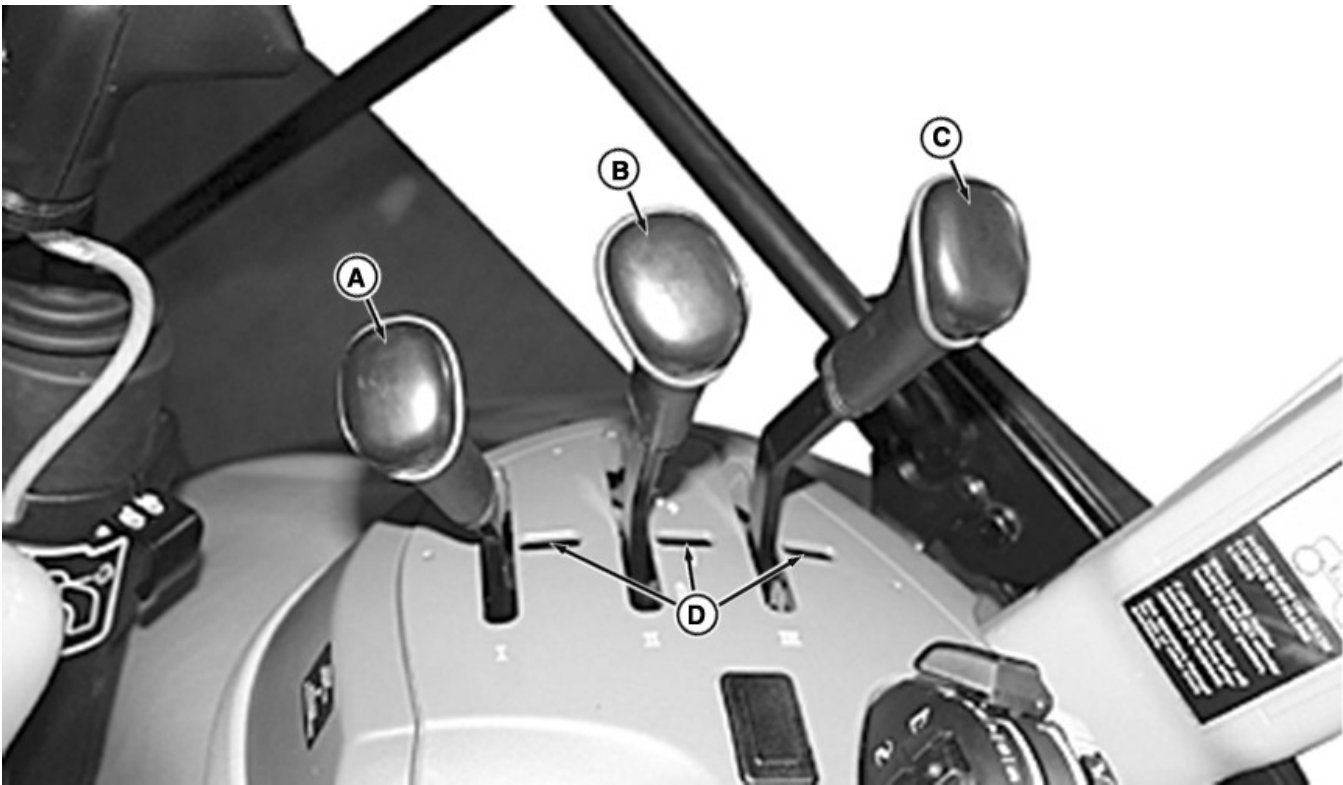

RXA0158456—UN—30MAR17

- A—SCV I Lever
- B—SCV II Lever

- C—SCV III Lever
- D—Transport Lock (3)

Rear SCV Components

Rear SCV Operation

SCV Levers

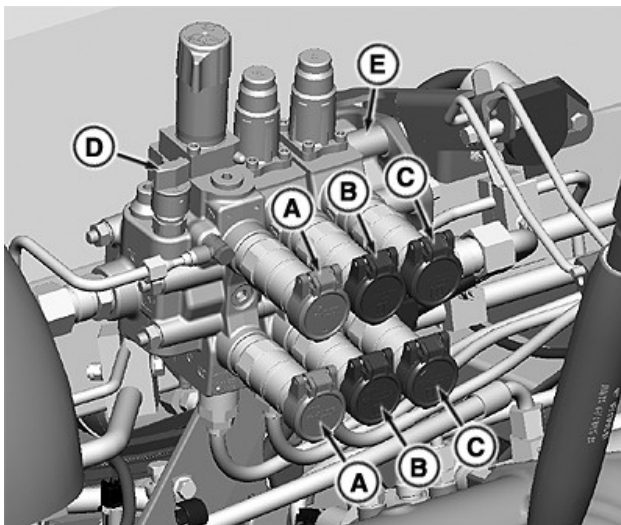

RXA0158458—UN—30MAR17

- A—SCV I
- B—SCV II
- C—SCV III
- D—Inlet Plate with Adjustable Flow Control
- E—End Plate

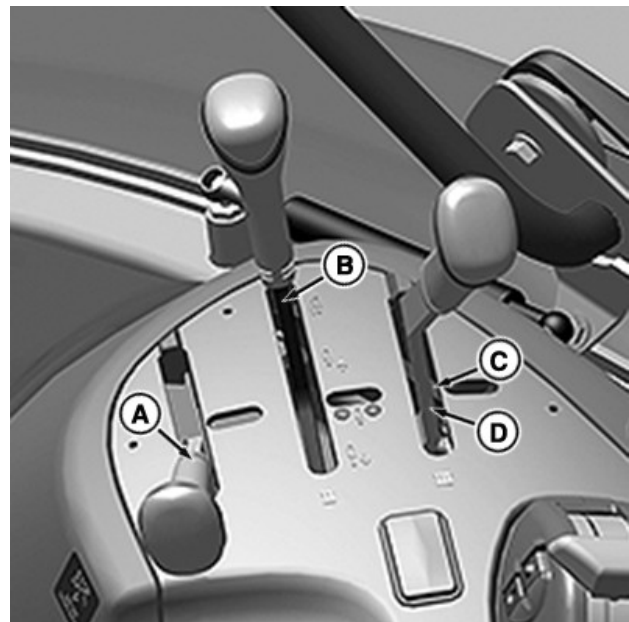

RXA0158459—UN—16MAY17

- A—Extend Position
- B—Float Position

C—Retract Position
D—Neutral Position

IMPORTANT: Use transport lock to avoid unintentional rear SCV movement during transport or while SCV levers are not in use.

Rear SCV levers have four positions:

- Extend - pull and hold lever rearward as required.
- Retract - push and hold lever forward as required.
- Neutral - release lever unless in the float detent. If in float, lever must be pulled rearward to return to neutral.
- Float - push lever forward past retract position and into the float detent.

Rear SCV Identification

SCV levers and couplers are color coded for easier identification. The SCV control matches the corresponding cap on the SCV.

Rear SCV Numbers and Corresponding Colors	
SCV Number	Color
SCV I	Green
SCV II	Blue
SCV III	Brown

MP60050.0000B23-19-08JUN21

Mid-Mount SCV Controls and Components

Mid-Mount SCV Controls

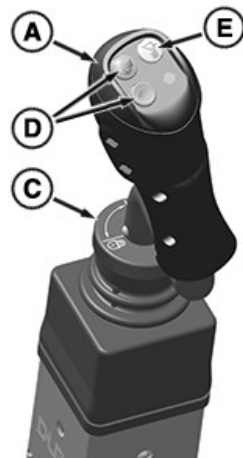

RXA0161910—UN—31JAN18

Mid-Mount SCV Joystick Lever

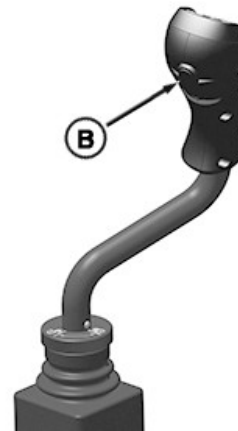

RXA0161911—UN—31JAN18

Mid-Mount SCV Joystick Lever

- A—Mid-Mount SCV Joystick Lever
B—Third-Function Switch
C—Mid-Mount SCV Joystick Lever Lock
D—Gearshift Buttons
E—Loader Suspension Button

Mid-Mount SCV Components

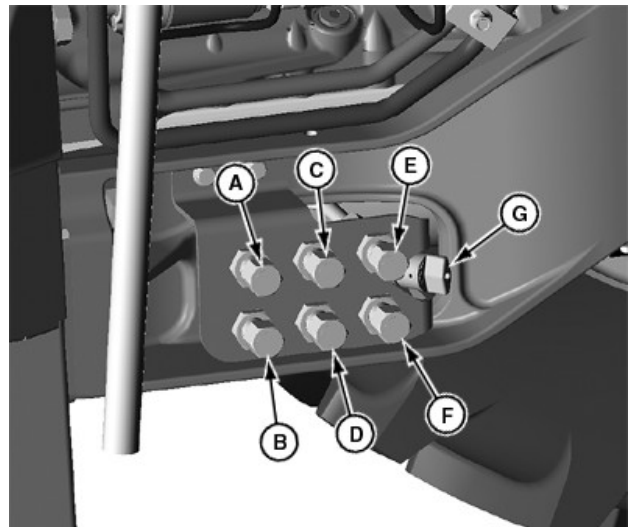

LV22040—UN—29JUL14

- A—SCV XI—Retract
B—SCV XI—Extend
C—SCV XII—Retract
D—SCV XII—Extend
E—SCV XIII—Retract
F—SCV XIII—Extend
G—Adjustable Flow Control

Mid-Mount SCV Operation

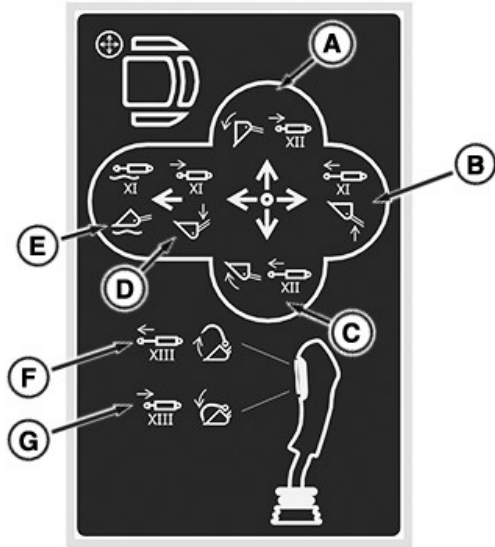

RXA0154082—UN—13OCT16

Mid-Mount SCV Joystick Lever Functions

CAUTION: The mid-mount SCV joystick lever must be locked when the loader or front hitch is not in use, transporting, or when operator dismounts the machine. Turn locking ring to locked position. Check that the loader or front hitch does not respond after locking. If not done, the loader or front hitch may be actuated unintentionally, which could lead to serious accidents.

Position	Direction	Loader Function	SCV Function
A	Right	Bucket Tilt (Dump)	SCV XII Retract
B	Rearward	Boom Raise	SCV XI Extend
C	Left	Bucket Rollback (Curl)	SCV XII Extend
D	Forward	Boom Lower	SCV XI Retract
E	Forward Detent	Boom Float	SCV XI Float
F	Top Button	Grapple Open	SCV XIII Extend
G	Bottom Button	Grapple Close	SCV XIII Retract

Mid-Mount SCV Loader Functions

Position	Direction	Front Hitch Function	SCV Function
A	Right	Front Hydraulic Coupler Retract	SCV XII Retract
B	Rearward	Lift Arm Raise	SCV XI Extend
C	Left	Front Hydraulic Coupler Extend	SCV XII Extend
D	Forward	Lift Arm Lower	SCV XI Retract
E	Forward Detent	Lift Arm Float	SCV XI Float

Position	Direction	Front Hitch Function	SCV Function
F	Top Button	Not Used	SCV XIII Extend
G	Bottom Button	Not Used	SCV XIII Retract

Mid-Mount SCV Front Hitch Functions

Mid-Mount SCV Identification

Mid-Mount SCV Numbers and Corresponding Colors	
SCV Number	Color
SCV XI	Green
SCV XII	Blue
SCV XIII	Brown

MP60050.0000A36-19-16JUN21

Connect Hydraulic Hoses

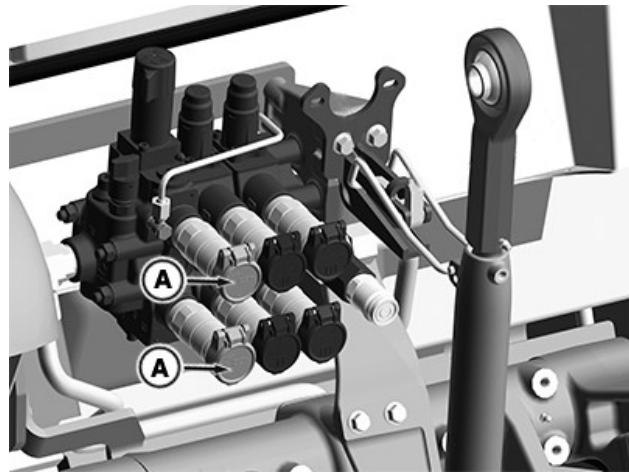

RXA0161474—UN—01DEC17

A—Coupler Cover

IMPORTANT: Hydraulic hoses can fail due to physical damage, kinks, age, and exposure. Check hoses regularly. Replace damaged hoses.

NOTE: Selective control valve (SCV) couplers accept a standard hose tip as recommended by ISO¹ and SAE². Adapters are available to update older hose tips to the ISO couplers on this machine.

NOTE: When making connections, it is helpful to relieve hydraulic pressure from the couplers. For mechanical SCVs, turn the key switch off and cycle the SCV levers to the float position.

Installing hydraulic hoses in SCVs:

1. Clean area around where connection is made and

¹ International Standards Organization (ISO) 7241-1
² Society of Automotive Engineers

end of implement hydraulic hoses to prevent hydraulic system contamination.

2. Open SCV coupler dust covers (A) as required.
3. Identify extend and retract hoses.
4. Firmly push hoses into couplers. Lightly tug on the hoses to ensure that connection is made. If connections are difficult, relieve pressure at couplers.

Removing hydraulic hoses from SCVs:

1. Lower implement to ground before disconnecting hydraulic hoses. If possible, retract remote cylinders as much as possible when stored to protect the rod from damage.
2. Shut off engine.
3. Relieve pressure at the couplers.
4. Lock out SCV controls.
5. Engage lock on mid-mount SCV joystick for mid-mount SCVs.
6. Pull hoses straight out from couplers.
7. Close SCV coupler dust cover.

GS25068,00018A2-19-29JUL21

Connect to Rear SCVs

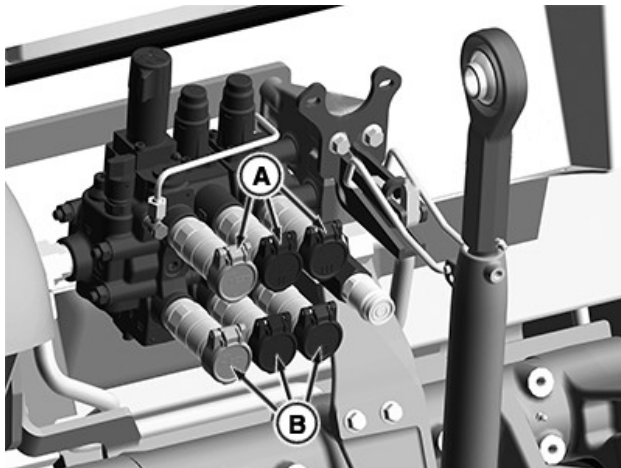

RXA0161476—UN—01DEC17

A—Retract Couplers
B—Extend Couplers

1. Identify extend and retract hoses.
2. Remove dust caps from hose end.
3. Open coupler covers.
4. Making sure that hose end and coupler are clean, push hose tip firmly into SCV coupler. Pull on hose, making sure that positive connection is made.
5. Connect retract hoses to top couplers (A) and extend hoses to bottom couplers (B).

GS25068,00059EC-19-04OCT18

Connect to Mid-Mount SCVs

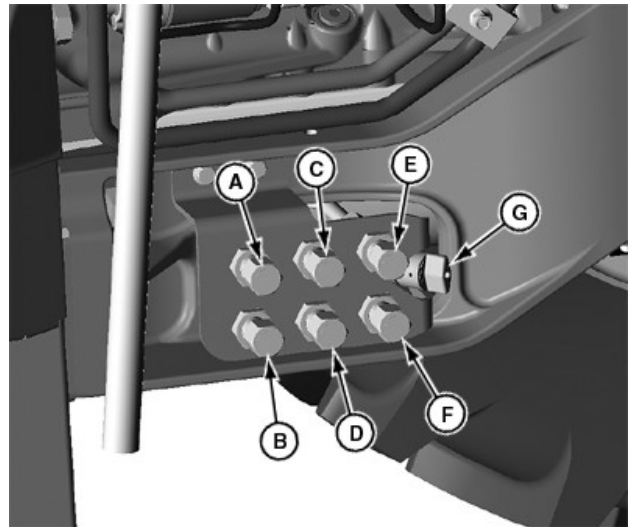

LV22040—UN—29JUL14

A—Boom Cylinder—Retract
B—Boom Cylinder—Extend
C—Bucket Cylinder—Retract
D—Bucket Cylinder—Extend
E—Third-Function Cylinder—Retract
F—Third-Function Cylinder—Extend
G—Adjustable Flow Control

IMPORTANT: Hydraulic hoses can fail due to physical damage, kinks, age, and exposure. Check hoses regularly. Replace damaged hoses.

NOTE: Connections are capped and require couplers to be installed if using hose with ISO ends. Direct connection to the fittings can be made for permanent applications.

1. Match hoses to corresponding couplers.
2. Remove dust caps from hose ends.
3. Remove cap assembly from the selective control valve (SCV) couplers.
4. Ensure that hose end and couplers are clean, slide sleeve back, push hose tip firmly into coupler, and release sleeve.
5. Make sure that positive connection was made by pulling on hose.

GS25068,00018A3-19-23JUL21

Correct Reversed Cylinder Response

⚠ CAUTION: If cylinder response is opposite of the SCV lever, extending when it should retract, reverse hose connections at couplers.

DP51502,0002E74-19-01NOV17

Single-Acting Cylinders

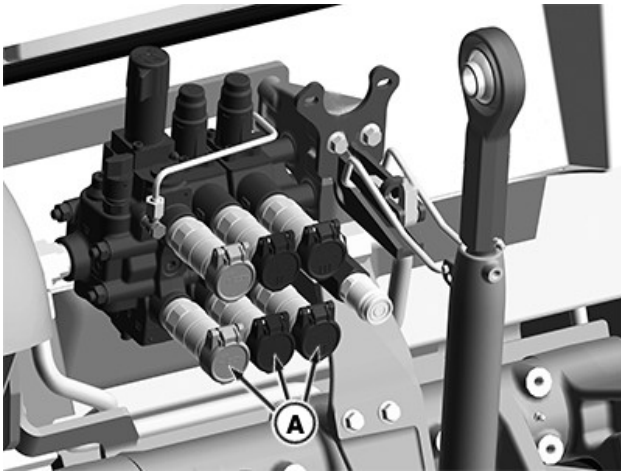

A—Extend Couplers

RXA0161477—UN—01DEC17

IMPORTANT: Volume of oil required to extend a cylinder lowers the transmission/hydraulic oil level. With cylinder fully extended, check oil level and fill to the proper level. (See Check Transmission/Hydraulic System Oil Level in the Hydraulics Maintenance section.)

Only connect single-acting cylinders to SCV extend coupler (A).

Pull SCV lever back to pressurize and extend a single-acting cylinder.

Push SCV lever fully forward to “float” position and retract the cylinder.

GS25068,00059EE-19-04OCT18

Implements Requiring Large Volumes of Oil

IMPORTANT: Removing too much oil can result in malfunction when raising hitch or using extend function of SCVs.

Do not add oil to hydraulic system with engine running.

To determine if sufficient oil is available for implement being used:

1. Cycle all implement cylinders after starting machine.
2. Check transmission/hydraulic oil level.
3. Add oil if necessary.
4. Lower implement to return oil to reservoir.
5. Recheck oil level when implement is removed.
6. Drain excess oil if necessary.

GS25068,00059EF-19-04OCT18

Set SCV Detents

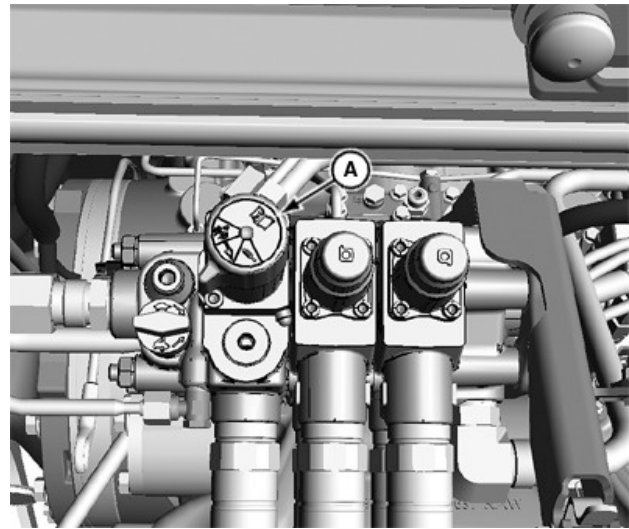

LV22089—UN—12JUN14

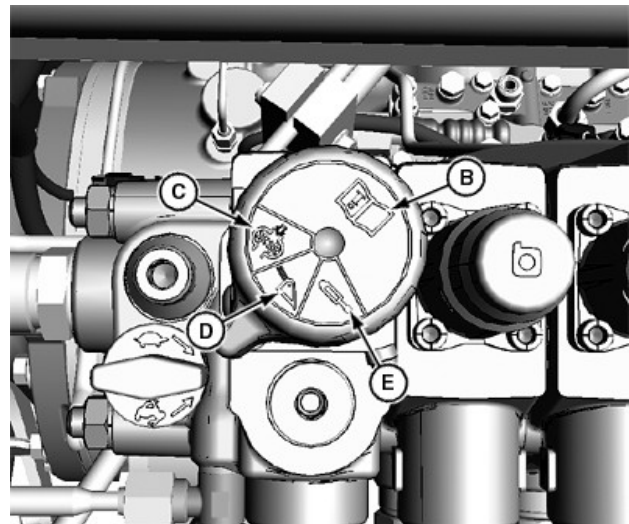

LV22090—UN—12JUN14

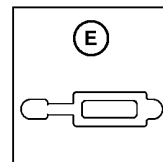
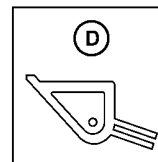
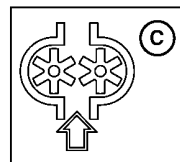
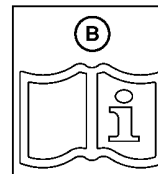

LV22102—UN—12JUN14

- A—SCV Detent Dial
- B—Read Operator's Manual
- C—Continuous Detent (Motor)
- D—No Detent (Loader)
- E—Automatic Detent (Cylinder)

IMPORTANT: To avoid overheating hydraulic oil and damage to machine, use SCV I when long duration “continuous” (motor) operation is required. Section I of deluxe SCV has a flow control valve. When properly adjusted, valve provides flow to operate an implement at required speed while maintaining oil temperature within normal operating range.

Section 1 of the deluxe SCV has selectable detents, used to change mid-mount SCV joystick operations to meet operating requirements of different implements. Detent settings affect only extend and retract lever positions, not “float.”

NOTE: Read Operator’s Manual symbol (B) is for reference only and is not a selectable setting.

SCV Knob Position	SCV Lever Detent
Continuous Detent (Motor) (C) for motor operation	Holds lever in operating position until manually returned to neutral.
No Detent (Loader) (D) for loader operation	Lever returns to neutral when released.
Automatic Detent (Cylinder) (E) for cylinder operation	Lever automatically returns to neutral when a cylinder reaches the end of stroke.

D3K5H22.00005F2-19-17MAY21

Operate Hydraulic Motor with Rear SCV

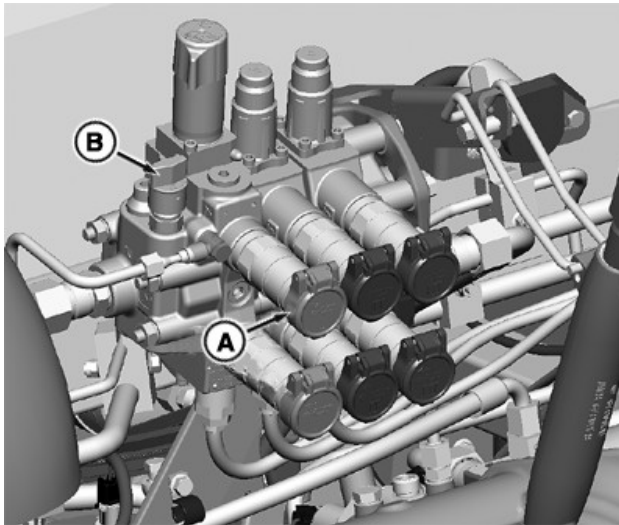

RXA0149443—UN—22JUL15

A—SCV I Retract Coupler
B—Adjustable Flow Control Valve

IMPORTANT: Avoid damage to hydraulic motors. Use only SCVs equipped with flow control or power beyond to operate hydraulic motors.

NOTE: To understand motor requirements, refer to implement operator’s manual.

Use SCV I retract coupler (A) with adjustable flow control for most hydraulic motor operations.

To regulate oil flow when operating a hydraulic motor with any standard valve without adjustable flow control, use an external flow control valve.

IMPORTANT: Never regulate oil flow from an SCV with a flow control valve using an external flow control valve. Having two flow control valves in the same hydraulic circuit overheats oil, causing component malfunctions and damage.

Do not use deluxe rear SCV for any low-flow, high-pressure applications such as the SeedStar variable rate drive planter motor or active downforce circuits. PTO driven hydraulic motor is recommended for low-flow, high-pressure applications.

Recommendations to Avoid Hydraulic Motor Damage

Use hydraulic motor return coupler for implements having:

- Single directional hydraulic motor.
- Hydraulic motor with a low-pressure shaft seal.
- Hydraulic motor with an internal case drain.

Use hydraulic motor case drain connection for implements having motor with a case drain line. (See Case Drain in this section.)

IMPORTANT: If implement motor is not equipped with return coupler, use “float” position to stop hydraulic motor.

Hydraulic Motor Hose Connections and SCV Lever Operations

IMPORTANT: Use only SCVs with adjustable flow control for “continuous” (motor) applications.

1. Shut off engine.
2. Move SCV lever to be connected to motor full forward, into “float” detent.
3. Connect hydraulic motor supply hose to the SCV retract coupler and return hose to the SCV extend, or case drain as required by application.
4. Set SCV lever detent for continuous “motor” operation.
5. Start engine.
6. Do not return hydraulic motor directly to sump via a port on differential case, except intermittent high-pressure applications, such as a post pounder.

To activate hydraulic motor, move SCV lever to “retract” position.

7. To stop hydraulic motor, move SCV lever fully forward into “float” detent.

IMPORTANT: To stop hydraulic motor, do not use neutral lever position.

8. Shut off engine and disconnect hoses from couplers.

MP60050,0000AEC-19-06MAY21

Operate Power Beyond with Rear SCV

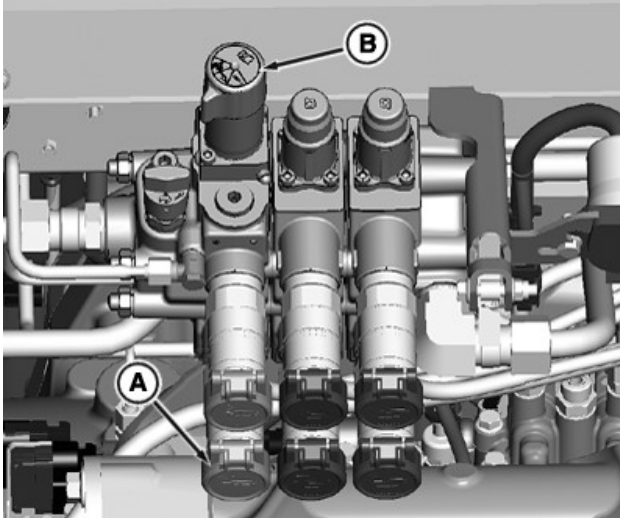

RXA0149424—UN—22JUL15

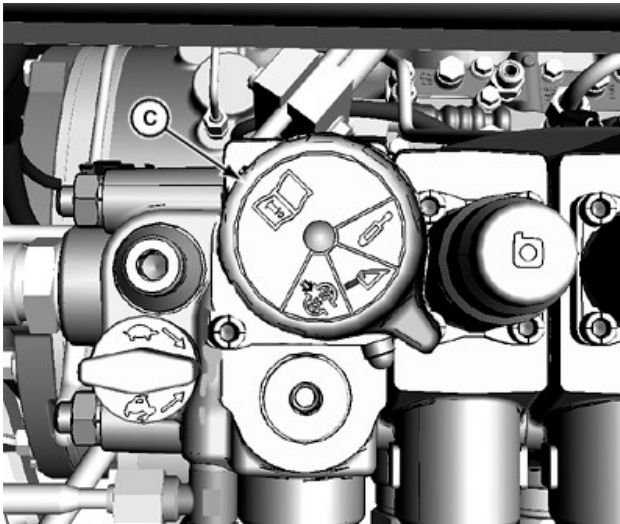

LV22103—UN—17JUN14

- A—Rear SCV I Extend Coupler
- B—SCV I Detent
- C—Continuous Detent Position

IMPORTANT: Power beyond connections must be used when operating any external hydraulic orbital motor with this machine. Failure to comply with power beyond connections overheats and possibly damages the hydraulic system.

NOTE: Oil can be supplied to power beyond equipment using SCV 1 on the deluxe SCV (in continuous mode) or by using a power beyond kit with the standard dual rear SCV.

1. Shut off engine.
2. Connect power beyond hose to rear SCV I extend coupler (A).
3. Set rear SCV I detent (B) to continuous (C).
4. Start engine.
5. Move SCV I lever into extend.
6. Oil is now supplied to power beyond device.
7. To stop, de-activate power beyond device, then return SCV I lever to neutral.
8. Shut off engine and disconnect hoses.

GS25068,00059F2-19-04OCT18

Operate Loader with Rear SCV

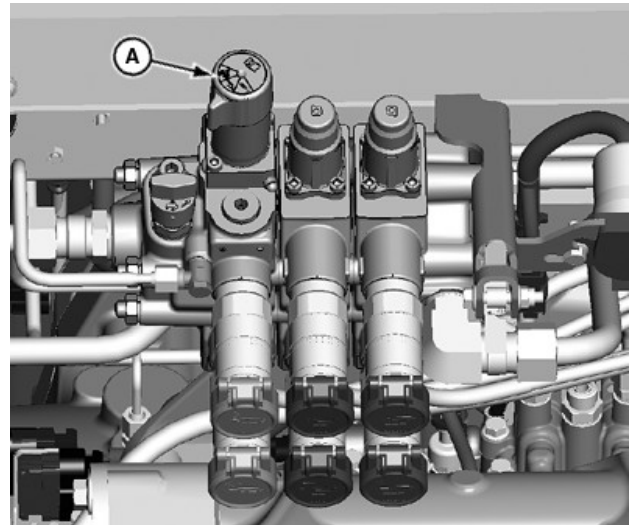

LV22106—UN—17JUN14

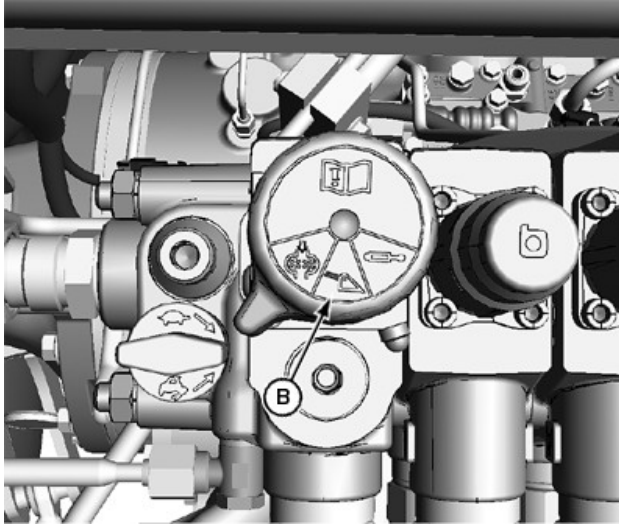

LV22107—UN—17JUN14

A—SCV Detent Selector Knob
B—No Detent (Loader) Position

CAUTION: Avoid injury or death caused by falling loads. When using selective control valve (SCV) to operate loader, detent must be set in loader setting (B), for loader movement to stop when SCV lever is released. Moving SCV lever to any other position would cause the loader to perform unexpectedly and potentially cause injury.

When using loader with rear SCVs, **ALWAYS** put the SCV detent selector knob (A) in loader setting (B) to prevent unexpected movement.

TO84594.000015B-19-17JAN18

Adjust Flow Control

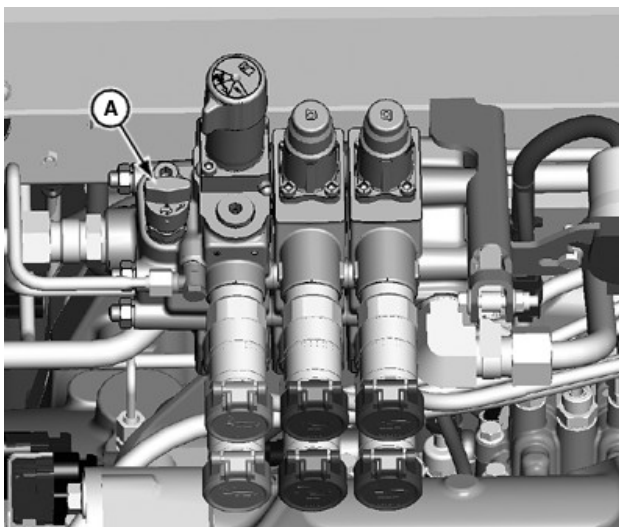

LV22108—UN—17JUN14

Rear SCV Adjustment

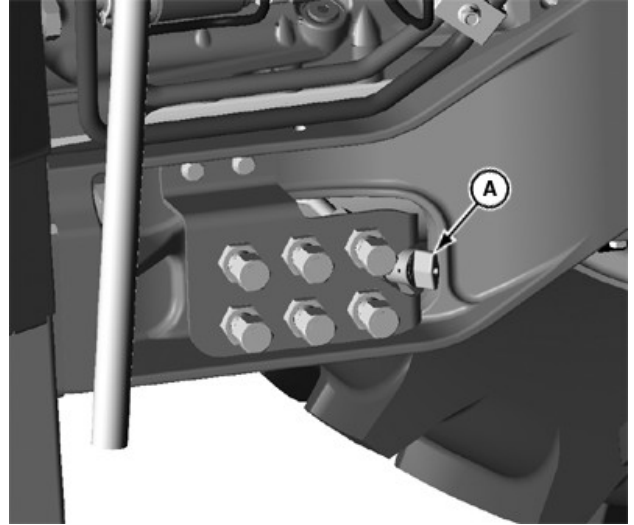

LV22123—UN—17JUN14

Mid-Mount SCV Adjustment

A—Flow Control Adjustment

CAUTION: Excessive operating speed may cause injury or machine damage.

Decrease flow rate if hydraulic oil overheats, remote cylinder moves too quickly, or if hydraulic motor turns too fast.

Flow control adjustment (A) only affects rear SCV I and the electrohydraulic (grapple) section of the three-function mid-mount SCV. This adjustment does not affect other valve sections.

To increase flow, rotate left (counterclockwise).

To decrease flow, rotate right (clockwise).

NOTE: Rear SCV: If detent kicks out before end of cycle, adjust flow control using SCV I.

GS25068.00018A4-19-23JUL21

Power Beyond

Power beyond is designed for applications where continuous high-volume hydraulic oil flow is needed.

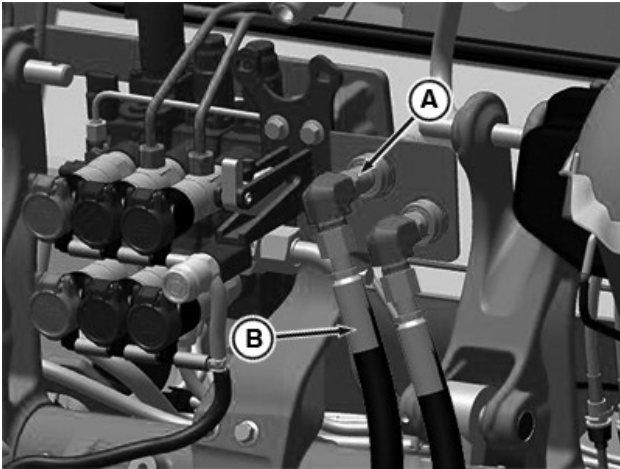

PY42083—UN—18MAY17

A—Hose Coupler
B—Power Beyond Hose

1. To use power beyond feature, remove hose (B) from coupler (A) and attach to implement “return” port.
2. To complete the hydraulic circuit, attach implement “pressure” hose to open coupler (A).
3. When not in use, plug hose end into coupler for storage (as shown).

Parts for this attachment are available from your John Deere dealer.

MP60050,0000A23-19-17FEB21

Parts for this attachment are available from your John Deere dealer.

DP51502,0002E7D-19-01NOV17

Motor Return

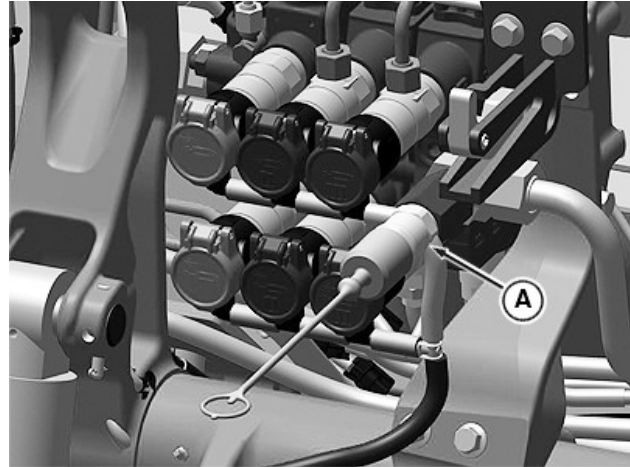

PY42080—UN—18MAY17

A—Motor Return Coupler

Connect motor return hose to the motor return coupler (A) to provide an unrestricted path to sump.

MP60050,0000A24-19-17FEB21

Case Drain

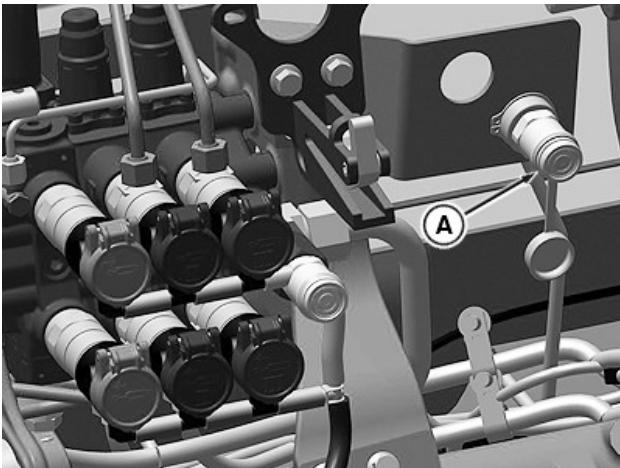

PY42082—UN—18MAY17

A—Flat-Faced Drain Connector

If implement motor is equipped with a case drain hose, attach it to the flat-faced drain connector (A). Make sure that the hose coupler and drain connector are clean before attaching. Install protective dust cap when connector is not in use.

Fast Return-to-Sump

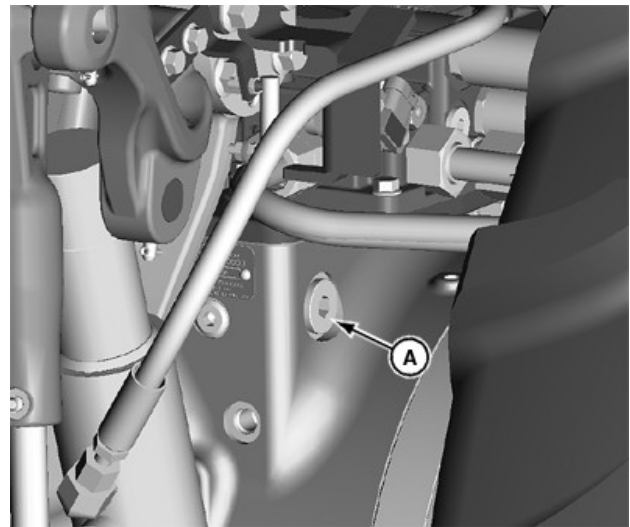

LV22143—UN—18JUN14

A—Plug

IMPORTANT: Use fast return-to-sump connection only for intermittent high-flow applications. Do not use for other applications.

Some implements, such as a post pounder, require use of a high-flow or fast return-to-sump connection.

If a high-flow return connection is needed, remove plug (A) from the transmission housing and install connector.

NOTE: Connector is available from your John Deere dealer.

GS25068,00059F5-19-04OCT18

Rear SCV Oil Collection

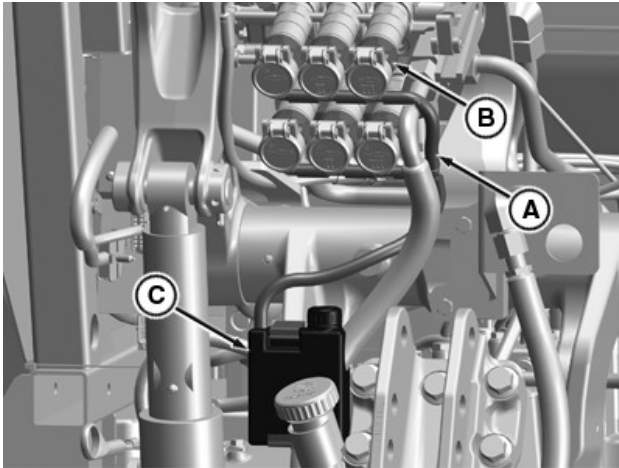

PY39985—UN—04MAY17

A—Hose
B—SCV Coupler
C—Oil Collection Bottle

Oil can leak during hose uncoupling with rear selective control valve (SCV). Collars installed onto couplers (B) capture oil and hoses (A) transfer oil to a removable collection bottle (C).

Parts for this attachment are available from your John Deere dealer.

TO84594,000015E-19-17JAN18

Wheels and Tires Operation

Wheels and Tires Information

Refer to the **Wheels and Tires Maintenance** section of this manual for information.

GS25068,00053F5-19-19SEP18

Ballasting

Ballasting Information

Refer to the Ballasting Maintenance section of this manual for information.

GS25068,00053F6-19-19SEP18

Additional Equipment

Tool Box

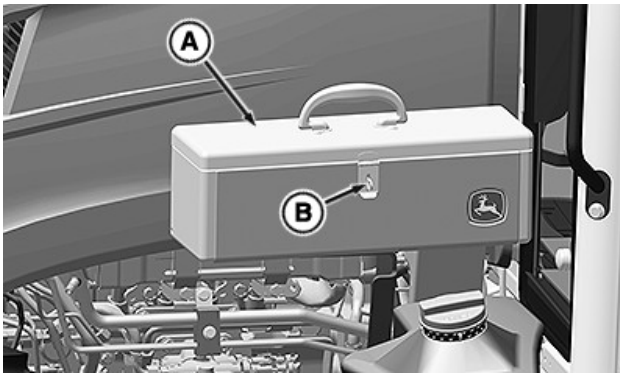

RXA0153913—UN—23SEP16

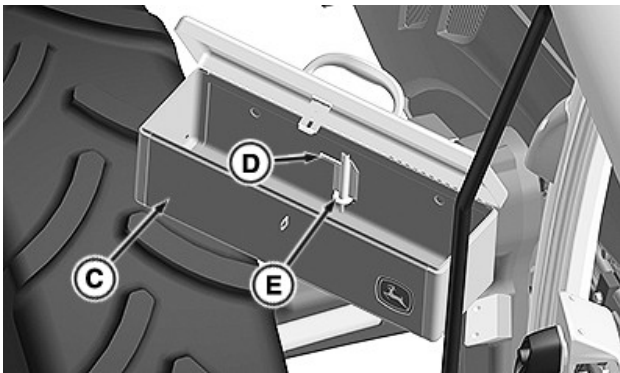

RXA0154070—UN—23SEP16

- A—Lid
- B—Latch
- C—Tool Box
- D—Removal Pin
- E—Retaining Tab

The tool box (C) is lockable and removable. To lock, close latch (B) and place a padlock through eye.

To remove tool box:

1. Lift latch (B).
2. Open lid (A).
3. Support bottom of the tool box (C).
4. Pull removal pin (D) upward to release.
5. Slide toolbox away from retaining tab (E) to release tool box.
6. Reverse process to reinstall.

DP51502.0002A96-19-02FEB17

Front Loader

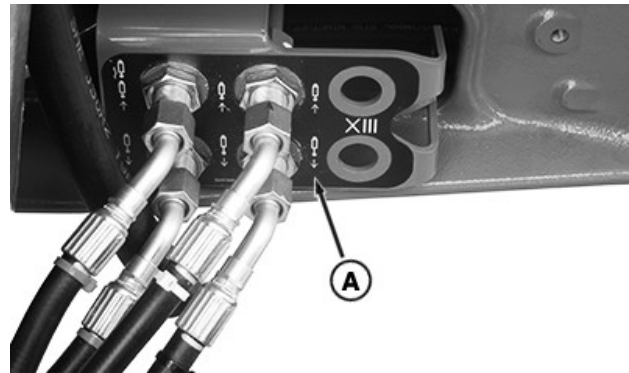

RXA0158463—UN—07APR17

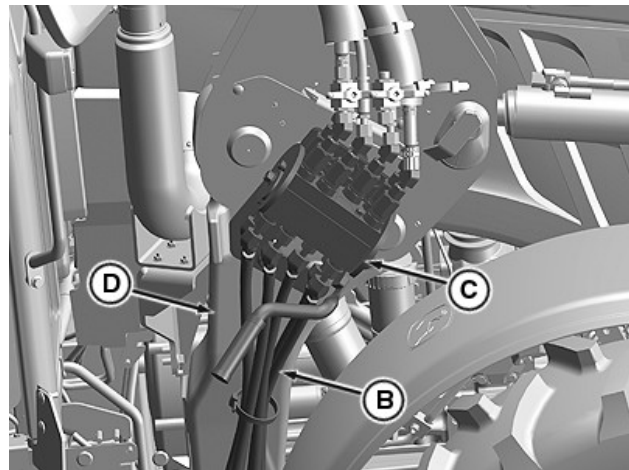

PY39988—UN—09MAY17

- A—Mid-Mount SCV Couplers
- B—Loader Extension Hoses
- C—Loader Multicoupler
- D—Loader Mounting Frame

- For information on installing the loader brackets, see Additional Equipment Maintenance section.
- For information on how to attach the loader to the machine and basic functionality, refer to the specific Loader Operator's Manual.
- For information on how to use the controls to operate the loader, see Selective Control Valve Operation section.
- For information on how to use loader lighting, see Electrical and Lighting Operation section.

GS25068.0001897-19-22JUL21

Front Loader Suspension Activation



RXA0170574—UN—19SEP19

Front Loader Suspension Icon



Front Loader Suspension Button

RXA0170573—UN—18SEP19

A—Front Loader Suspension Button

1. Hold the front loader suspension button (A) and switch on the ignition.
2. Hold the front loader suspension button (A) until the LED in the button starts to flash.
3. Release the front loader suspension button (A).
4. Press the front loader suspension button (A) again within 5 seconds to gain access to the programming mode.
5. Current programming of the front loader suspension system is as follows:
 - LED OFF, front loader suspension system deactivated.
 - LED ON, front loader suspension system activated.
6. Press the front loader suspension button (A) to active or deactivate the front loader suspension system.
7. To leave the programming mode and save the setting, press any button on the mid-mount SCV joystick lever or switch off the ignition.

IMPORTANT: Cycle the lift cylinders circuit several times to bleed air before testing.

8. Test the front loader suspension system.

MP60050,0000A25-19-17MAY21

Lockable Fuel Fill Cap

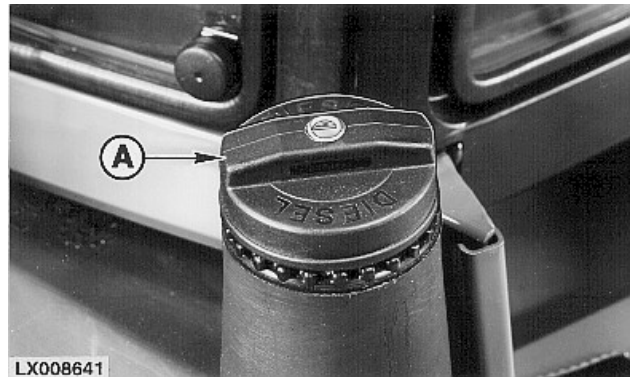

LX008641

LX008641—UN—15AUG94

A—Lockable Fuel Fill Cap

NOTE: It is recommended to use a vented locking fuel cap for all machines.

Machine can be equipped with a lockable fuel fill cap (A).

GS25068,0003EC9-19-06FEB18

Hood Latch



PY42165—UN—24AUG17

Hood Latch Location

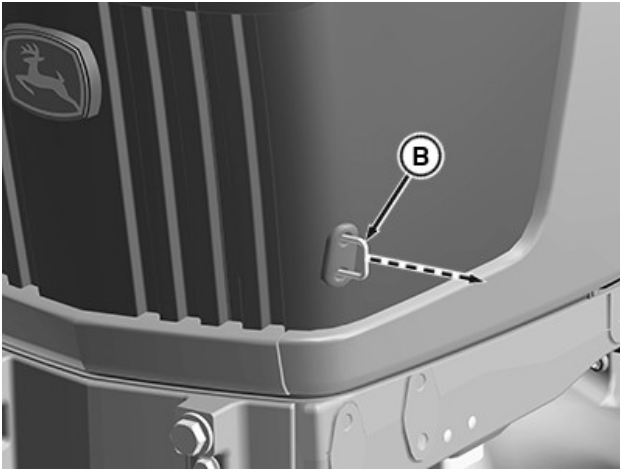

PY42166—UN—24AUG17

A—Hood Latch

B—Hood Latch Release Rod

1. Shut off engine and remove ignition key.
2. Hood latch (A) is located below left headlight on the left side of the hood.
3. Pull the hood latch release rod (B) outward to release the latch.
4. Lift the hood to open the engine compartment.

GS25068,00053F8-19-19SEP18

Operator's Station Operation

Doors



RXA0153901—UN—22SEP16

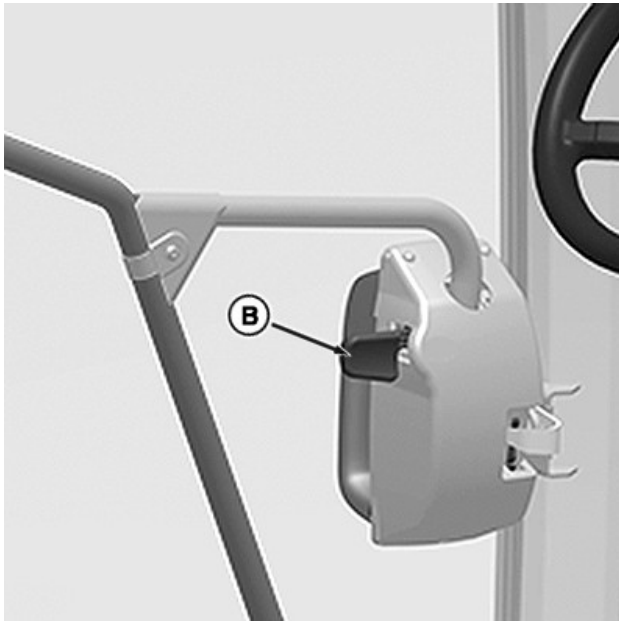

RXA0158465—UN—07APR17

- A—Exterior Door Latch**
- B—Interior Door Latch**

Depress the button on the exterior door latch (A) to release and pull to open door. An optional exterior locking latch is available.

Pull interior door latch (B) to release and push to open door.

MP60050,00009DF-19-03APR17

Grab Handles

Exterior Handle



RXA0158466—UN—07APR17

- A—Exterior Grab Handle**

Both front corners are equipped with an exterior grab handle (A) to assist the operator with entering and exiting the cab.

Interior Handles

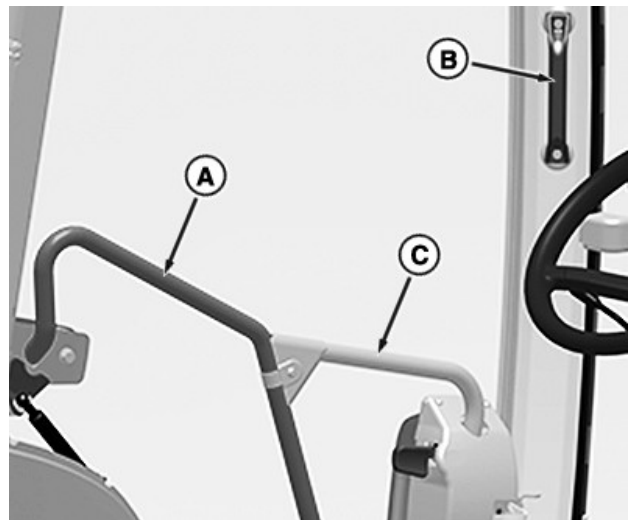

RXA0158468—UN—07APR17

- A—Door Grab Handle**
- B—Corner Post Grab Handle**
- C—Instructional Seat Grab Handle**

Both doors are equipped with grab handles (A) to assist operator with entering and exiting the cab. The handles are also used to assist with opening and closing the doors.

The corner post grab handle (B) is used to assist the operator when getting into and out of the seat.

The instructional seat grab handle (C) is used by the person in the instructional seat to hold during operation and to assist with opening and closing the door.

MP60050,0000A3B-19-24FEB21

Windows

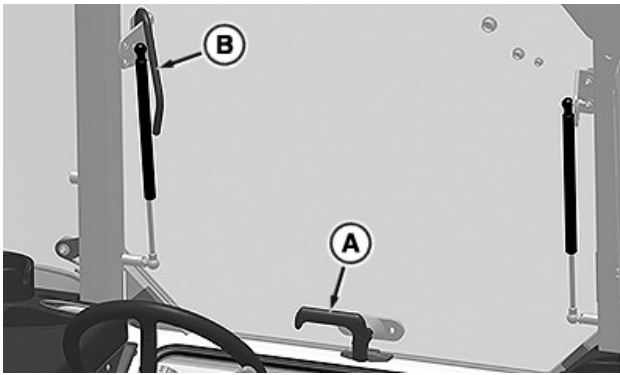

RXA0153908—UN—22SEP16

A—Rear Window Latch
B—Window Handle

⚠ CAUTION: In an emergency situation, rear window provides an exit path if cab doors are blocked. The panoramic sunroof does not open under any circumstance.

Rear Window

Rotate rear window latch (A) clockwise and push window open.

Pull on window handle (B) to close window and rotate window latch counterclockwise to secure.

Side Window

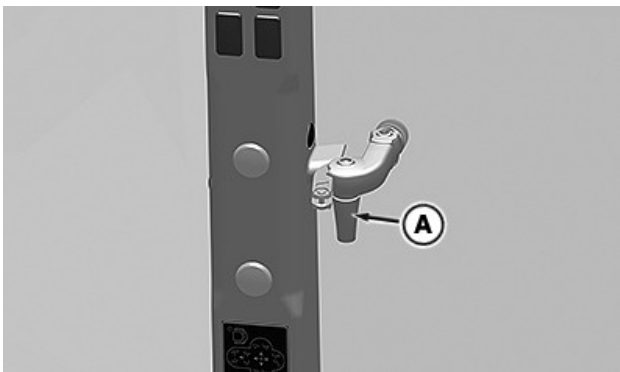

RXA0153909—UN—22SEP16

A—Side Window Latch

Pull side window latch (A) rearward and push side window outward to open.

GS25068,00053F9-19-19SEP18

Window Shades

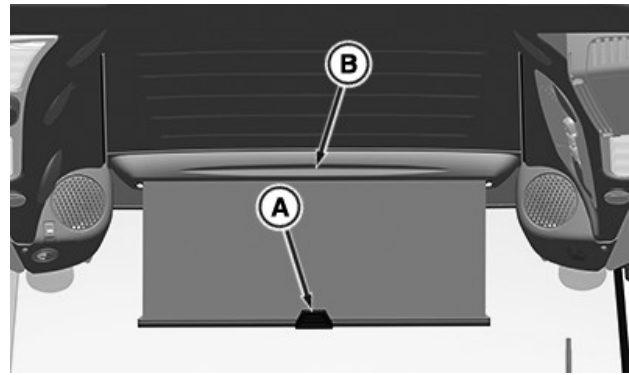

RXA0153904—UN—22SEP16

A—Front Window Shade
B—Roof Window Shade

Pull front window shade (A) straight down to desired position. Shade can be positioned anywhere between fully open and closed. Push shade up to retract.

Pull roof window shade (B) rearward to open and forward to close.

MP60050,0000A3C-19-24FEB21

Mirrors

Exterior Telescoping Mirrors

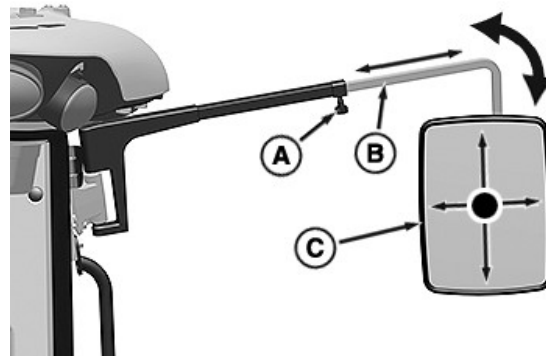

RXA0153903—UN—22SEP16

A—Mirror Arm Adjustment Screw
B—Mirror Arm
C—Mirror

Loosen mirror arm adjustment screw (A) and slide mirror arm (B) inward or outward to desired position. Securely tighten locking knob when adjustment is complete. Push mirror arm forward or pull rearward to desired position. Push mirror (C) up, down, left, or right to move into desired position.

Interior Rearview Mirror

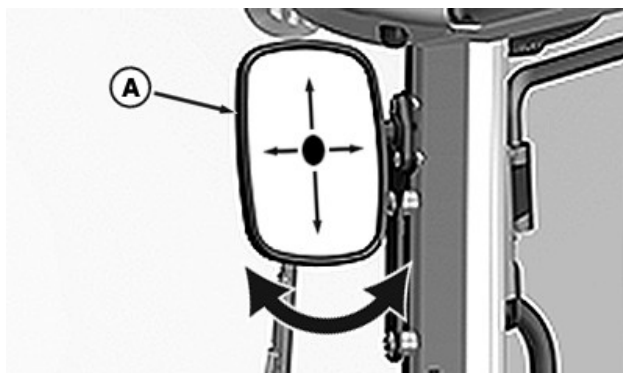

RXA0158472—UN—07APR17

A—Mirror

Push mirror (A) up, down, left, or right to move into desired position.

Hitch Rearview Mirror



RXA0154064—UN—23SEP16

A—Hitch Rearview Mirror

Push hitch rearview mirror (A) up, down, left, or right to move into desired position to view the hitch and drawbar area.

MP60050,0000A28-19-18FEB21

Cab Seats

Mechanical Seat



RXA0158478—UN—04APR17

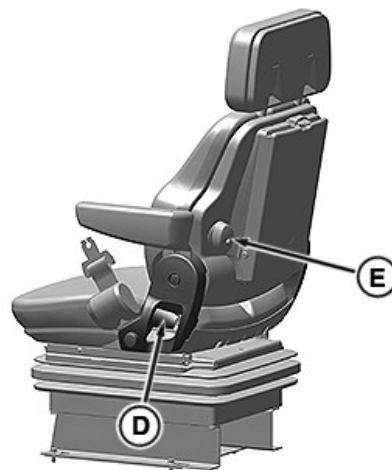

RXA0158479—UN—04APR17

- A—Seat Belt
- B—Forward or Backward Adjustment Lever
- C—Weight Adjustment Lever
- D—Backrest Adjustment Handle
- E—Lumbar Support Adjustment Knob
- F—Back Rest Extension

CAUTION: To avoid accidents, adjust the seat before driving.

IMPORTANT: While adjusting seat, make sure that all controls can be easily accessed.

Adjust the following to operator preference:

Seat Belt

1. Pull tab end of the seat belt (A) to extend.
2. Push tab into latch end until an audible click is heard.
3. Tug on the seat belt to ensure that it is latched.
4. Upon exiting, depress the button on latch to release.

Forward or Backward Adjustment

1. Lift forward or backward adjustment lever (B).
2. Slide seat to desired position.
3. Release forward or backward lever (B) to lock seat in position.

Weight Adjustment

1. Flip out weight adjustment lever (C).
2. Turn lever clockwise (increase load) or counterclockwise (decrease load) to reach desired suspension travel for operator's weight.

IMPORTANT: Stop turning lever (C) counterclockwise (decreasing load) when seat reaches minimum weight position and lever resistance increases. Seat mechanism could be damaged.

NOTE: Adjustable weight range is 40-150 kg (88-330 lb). Suspension should not bottom out when properly adjusted.

3. Return lever (C) to lock seat in position.

Backrest Adjustment

1. Lift on backrest adjustment handle (D).
2. Adjust backrest to desired position.
3. Release handle to lock backrest into position.

Lumbar Support

Turn lumbar support adjustment knob (E) clockwise or counterclockwise until desired lumbar support is reached.

Back Rest Extension

Back rest extension (F) is available for extended back rest support.

Air Suspension Seat



RXA0158624—UN—04APR17

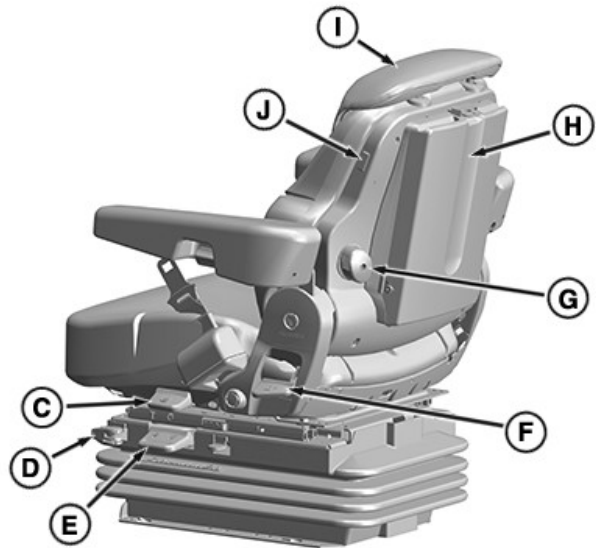

RXA0158625—UN—07APR17

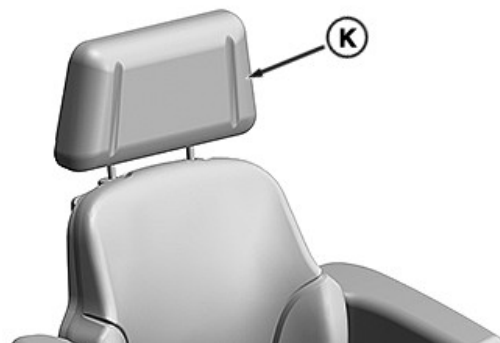

RXA0158626—UN—04APR17

A—Forward/Rearward Adjustment Lever
B—Seat Belt

- C—Swivel Adjustment Lever
- D—Forward/Rearward Suspension Adjustment Lever
- E—Weight Adjustment Lever
- F—Backrest Angle Adjustment Lever
- G—Lumbar Adjustment Knob
- H—Operator's Manual Compartment
- I—Back Rest
- J—Heated Seat Switch
- K—Back Rest Extension

CAUTION: Wear seat belt at all times during machine operation.

NOTE: Adjust with the operator in the seat for best results.

Seat Belt

1. Pull tab end of the seat belt (B) to extend.
2. Push tab into latch end until an audible click is heard.
3. Tug on the seat belt to ensure that it is latched.
4. Upon exiting, depress the button on latch to release.

Forward/Rearward Adjustment

1. Lift forward/rearward adjustment lever (A) up.
2. Select desired position.
3. Release lever to lock in position.

Forward/Rearward Suspension Adjustment

- Flip lever (D) forward for forward/rearward suspension.
- Flip lever rearward for NO forward/rearward suspension.

Weight Adjustment

1. Lift weight adjustment lever (E) up.
2. Reach desired suspension for operator's weight.
3. Release lever to lock seat in position.

Backrest Angle Adjustment

1. Lift backrest angle adjustment lever (F).
2. Tilt backrest (I) forward or rearward as desired.
3. Release lever to lock in position.

Lumbar Adjustment

Rotate lumbar adjustment knob (G) to increase or decrease support.

Swivel Adjustment

1. Lift swivel adjustment lever (C) up.
2. Rotate seat to desired position. Seat turns 15° to the right and left. Seat locks at 7.5° intervals.
3. Release lever to lock in position.

Heated Seat

Turn heated seat switch (J) on or off as desired.

Back Rest

The back rest (I) also has a back rest extension (K).

Operator's Manual Compartment

You can access your operator's manual by using the operator's manual compartment (H).

MP60050,0000AED-19-06MAY21

Adjust Seat Armrests

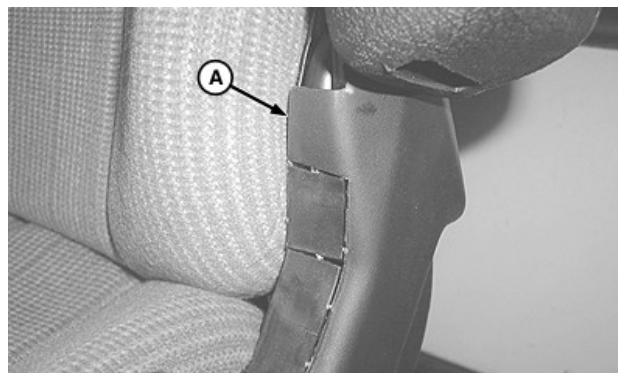

LV9044—UN—17NOV03

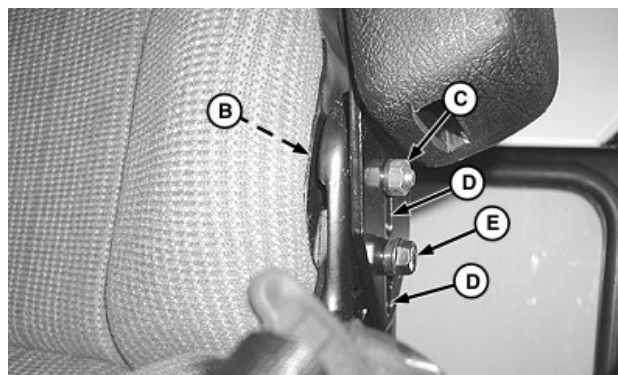

LV9045—UN—17NOV03

- A—Plastic Cover
- B—Cap Screw
- C—Nut
- D—Adjustment Slot
- E—Cap Screw

1. Pry plastic cover (A) away from seat.
2. Loosen cap screws (B and E).
3. Slide armrest up or down to desired height, and tighten hardware.

DP51502,0002B6E-19-03FEB17

Instructional Seat

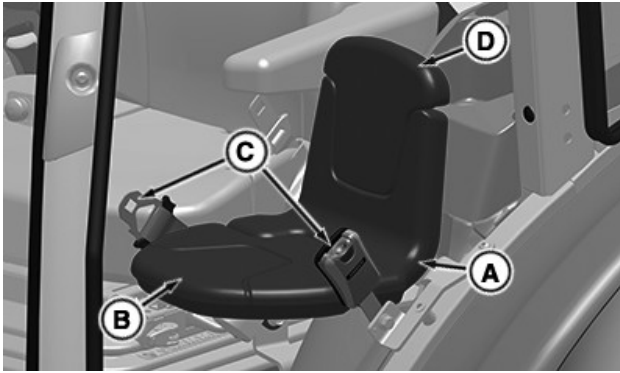

RXA0154077—UN—23SEP16

- A—Instructional Seat
- B—Seat Bottom
- C—Seat Belt
- D—Backrest

CAUTION: Instructional seat (A) is provided only for training operators or diagnosing machine problems. Keep all other riders off machine and equipment. Always wear seat belt (C).

Seat bottom (B) is spring-loaded and has no lock or unlock mechanism to fold or unfold. Push seat bottom upward or downward as required.

Seat backrest (D) extends by pulling upward in the center and retracts by pushing downward.

MP60050,0000A3D-19-24FEB21

Steering Wheel

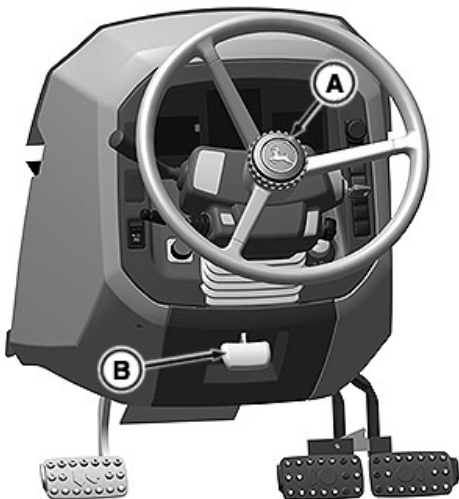

RXA0181059—UN—18FEB21

- A—Steering Wheel Telescope Release Knob
- B—Steering Wheel Tilt Release Lever

Telescope: Rotate steering wheel telescope release knob (A) counterclockwise. Extend or retract the steering wheel to desired position. Rotate knob clockwise to lock.

Wheel Tilt: Pull up on steering wheel tilt release lever (B) and move steering wheel to desired position. Release lever to lock.

MP60050,0000A2B-19-18FEB21

Heat, Defrost, and Air Conditioning

Temperature Controls

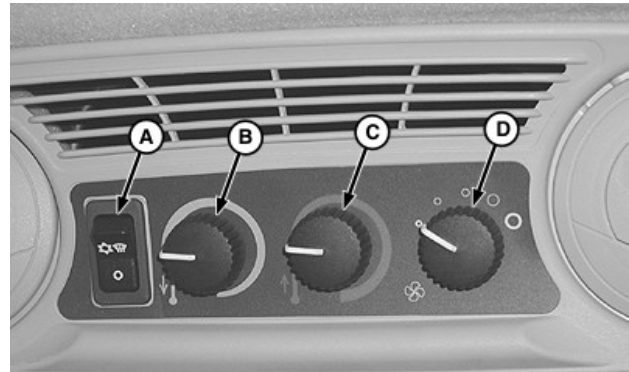

LV8415—UN—14JUL03

- A—Air Conditioner and Defog Switch
- B—Air Conditioner Temperature Control Knob
- C—Heater Temperature Control Knob
- D—Fan Speed Control Knob

- Push top half of switch (A) to turn on air conditioner/defog.
- Turn control knob (B) to adjust air conditioner temperature.
- Turn control knob (C) to adjust heater temperature.

Fan Speed Control

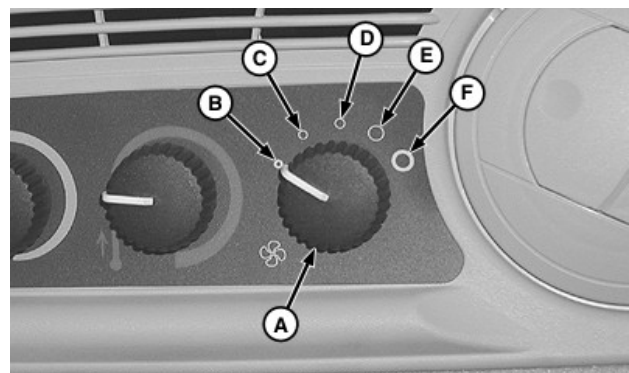

LV8414—UN—14JUL03

- A—Fan Speed Control Knob
- B—Off
- C—Low
- D—Medium
- E—High
- F—Purge

Turn fan speed control knob (A) to desired heater,

ventilation, or air conditioner setting. For a rapid cab cool down, use the purge setting (F).

Defog



LV8596—UN—14AUG03



LV14769—UN—09SEP11

- A—Front Vent
- B—Side Vent
- C—Defog Switch
- D—Air Conditioner Temperature Control Knob
- E—Heater Temperature Control Knob

1. Aim front vents (A) toward windshield.
2. Aim small side vents (B) toward the side window

NOTE: Closing all upper vents will defog the windshield faster.

3. Press top half of defog switch (C) and turn air conditioner temperature control knob (D) to full counterclockwise position.
4. Turn heater temperature control knob (E) clockwise to obtain desired temperature.

Heat and Air Vent Control

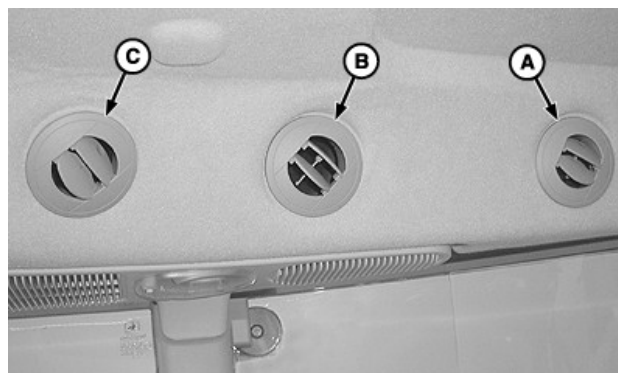

LV10325—UN—21SEP04

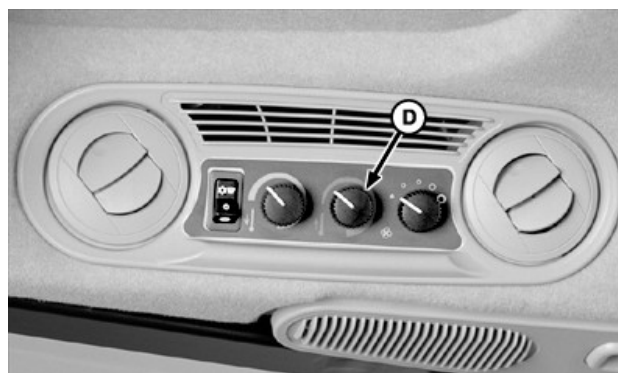

LV10326—UN—21SEP04

- A—Front Vent
- B—Middle Vent
- C—Rear Vent
- D—Heater Temperature Control Knob

Adjust individual vents to target heating or cooling:

- Aim front vents (A) toward legs and mid-body.
- Aim middle vents (B) toward your head.
- Aim rear vents (C) toward your back.
- Aim all vents (A, B, and C) down to heat the floor and feet.

NOTE: For maximum cooling effect, turn heater temperature control knob (D) to full counterclockwise position.

GS25068,00053FE-19-19SEP18

Storage Drawer

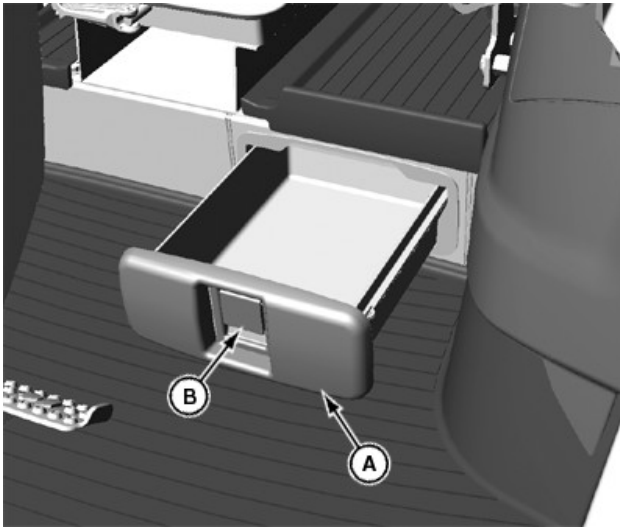

A—Storage Drawer
B—Drawer Handle

LV22339—UN—10JUL14

Storage drawer (A) is provided as an added convenience for operator. Pull outward on drawer handle (B) to open.

GS25068,00053FF-19-19SEP18

Left-Hand Storage

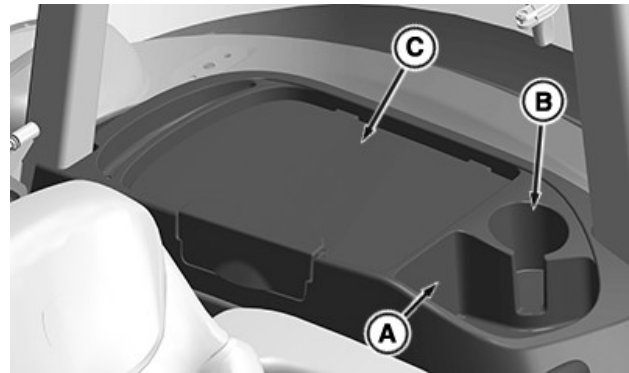

RXA0154067—UN—23SEP16

A—Storage
B—Beverage Holder
C—Writing/Computer Surface

MP60050,0000A2C-19-18FEB21

General Storage

Right-Hand Storage

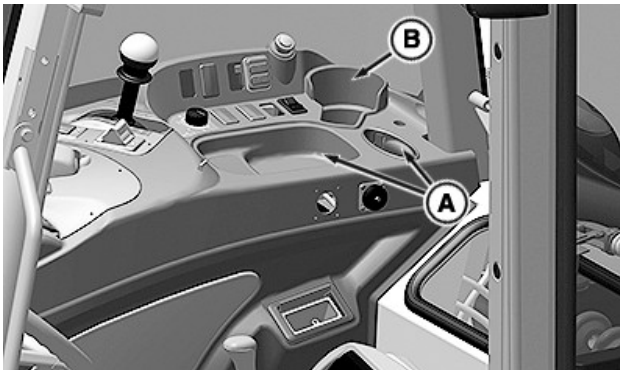

A—Storage
B—Beverage Holder

RXA0158628—UN—04APR17

Field Office

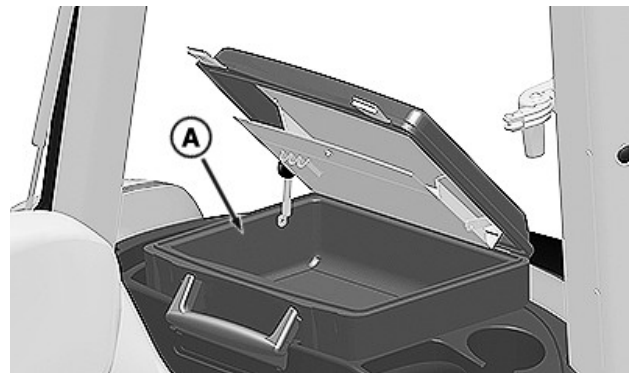

RXA0153920—UN—23SEP16

A—Field Office

Field Office (A) is a removable box to store documents and other items while working in the field.

Close lid, grasp handle, and pull up to remove. Align and depress to snap into place. Open lid as required, keep closed at all other times.

GS25068,0005400-19-05MAY21

Monitor Mounts

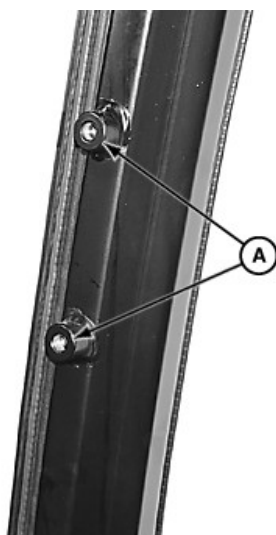

Front Post

LV14520—UN—02AUG11

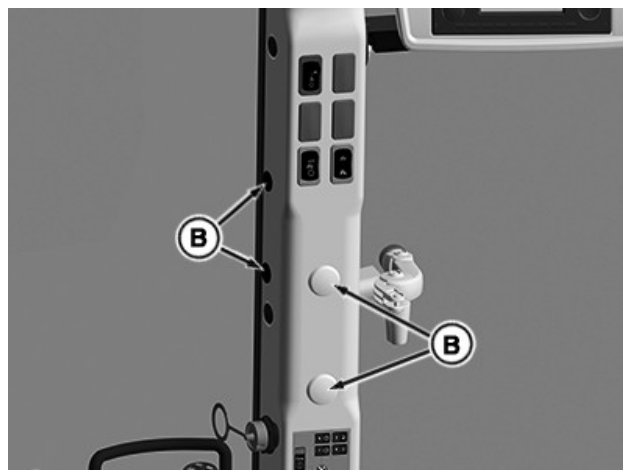

Side Post

RXA0164105—UN—09AUG18

A—Front Right Corner Post Mounting Locations
B—Right Side Post Mounting Locations

Install monitor at front right corner post mounting locations (A) or right side post mounting locations (B).

MP60050,0000A2F-19-22FEB21

Rear Window Cable Routing

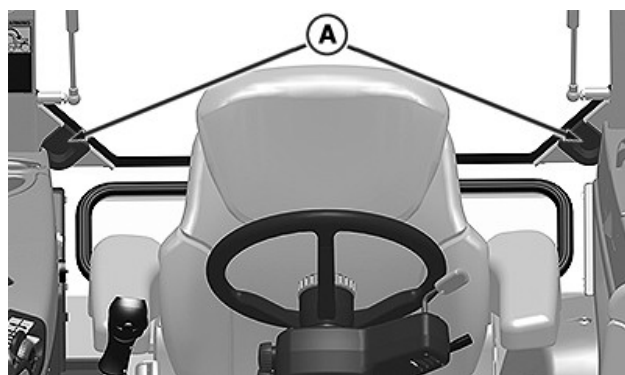

RXA0154076—UN—23SEP16

A—Cable Routing Locations

The rear window of the cab is provided with two openings, allowing the cables to be routed.

1. Open the window and take out the rubber stoppers.
2. Cut the rubber stoppers at the incisions provided to enable the cables to be routed.
3. Route cables and make connections as required.
4. Insert the rubber stoppers and close the window.

DP51502,0002AA6-19-02FEB17

Coat Hook

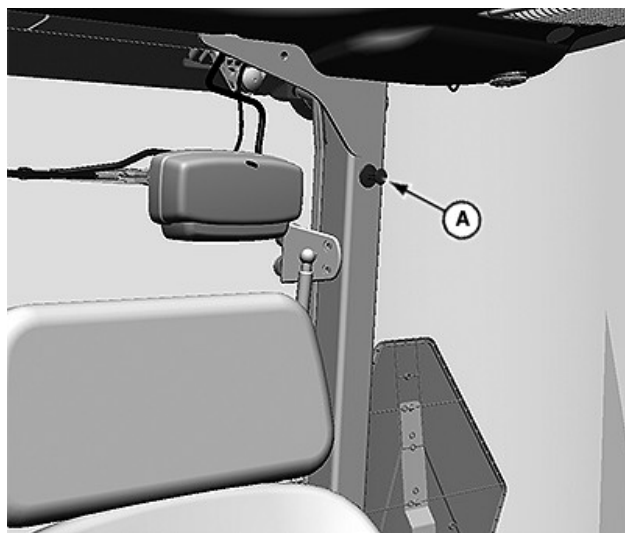

LV22757—UN—19AUG14

A—Coat Hook

Coat hook (A) is supplied for operator's convenience.

GS25068,0005402-19-19SEP18

Ash Tray and Cigarette Lighter

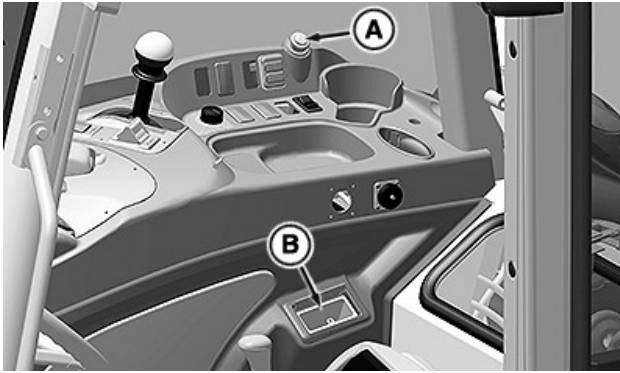

RXA0158630—UN—04APR17

- A—Cigarette Lighter
- B—Ash Tray

Depress cigarette lighter (A) to heat. Open the ash tray (B) lid to use.

MP60050,00009EE-19-04APR17

Transport and Storage

Keep Machines Secure

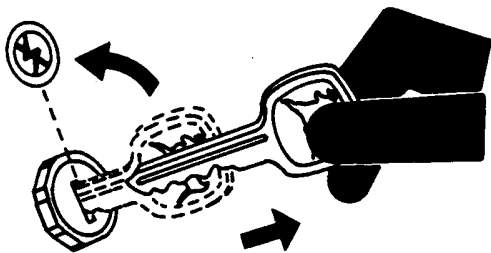

TS230—UN—24MAY89

1. Install vandal-proof devices.
2. When machine is in storage:
 - Lower equipment to the ground
 - Set wheels to widest position to make loading more difficult
 - Remove any keys and batteries
3. When parking indoors, put large equipment in front of exits and lock your storage buildings.
4. When parking outdoors, store in a well-lighted and fenced area.
5. Make note of suspicious activity and report any thefts immediately to law enforcement agencies.
6. Notify your John Deere dealer of any losses.

DX,SECURE2-19-18NOV03

Deliver Safely

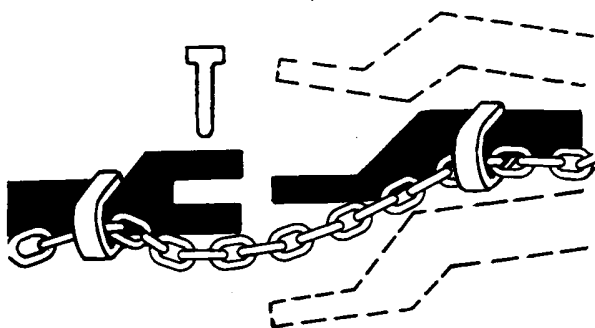

TS217—UN—23AUG88

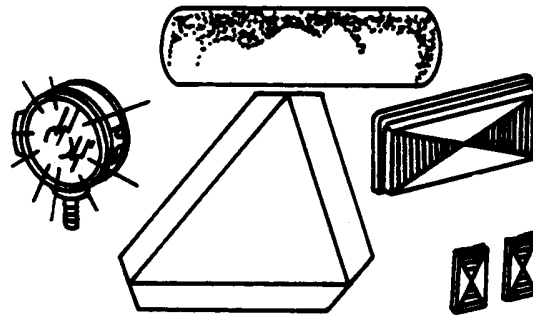

TS949—UN—22MAR90

The best method for delivering tractors, self-propelled equipment, and most implements or attachments is on a flatbed truck or trailer. Secure loads with tie down chains, straps, and binders.

Be aware of height and width restrictions to avoid collision with overpasses, bridge abutments, or other road users. Check with local authorities regarding oversized load transport restrictions and requirements.

When towing, remember that towed loads can swerve, upset or cause loss of control when towed with an undersized towing unit.

Never tow an implement behind a truck or other motor vehicle. The ability to maintain control and brake the implement and vehicle mass is compromised. The ability to properly attach the implement hitch and safety chain to the motor vehicle may be marginal. With most motor vehicles it is not possible to properly operate the warning, tail and turn signal lights on the implement, and in most cases the implement tires are not rated for highway speeds.

Tow drawn implements only with a properly sized and weighted tractor equipped with a stationary drawbar. (See tractor operator's manual for ballast requirements.)

Integral and semi-integral implements should be attached to a tractor with a three-point hitch as specified in the implement operator's manual. The tractor should have the proper size rear tires and the sway blocks should be in the down position. Do not transport unless the tractor front end is ballasted to the weight levels specified in the tractor operator's manual for the correct implement code.

Before transporting, attach a properly sized safety tow chain between the implement and tractor.

Stopping distance increases with speed and weight of towed loads, and when transporting on slopes. Observe these recommended maximum road speeds, or local speed limits that may be lower:

- If towed equipment does not have brakes, do not transport at speeds above 32 km/h (20 mph) and do not tow loads that weigh more than 1.5 times the weight of the tractor.
- If the towed equipment has brakes, do not transport

at speeds above 40 km/h (25 mph) and do not tow loads more than 4.5 times the weight of the tractor.

Use additional caution and reduce speed when towing under adverse surface conditions, when turning, and when on inclines.

Attach the implement lighting harness to the tractor and make sure that the warning and taillights on both the tractor and implement are on and functioning properly.

Make sure that the SMV and other markings on the implement are clean and visible.

DX,DELIVER-19-26JUL19

Road Transportation

⚠ CAUTION: Before operating machine on public roadways, familiarize yourself with the machine and the controls. Read this manual thoroughly, familiarize yourself with the machine, and understand how to use all of the controls. Consider weather, type of towed implement, roadway surface, lighting conditions, and traffic when operating on public roadways.

When transporting, use adequate accessory lights and devices to warn operators of other machines. Frequently check for traffic from the rear, especially in turns. Use your turn signals. Check local governmental regulations. Various safety devices are available from your John Deere dealer. Keep safety items in good condition. Replace missing or damaged items.

The following items must be considered before transporting on public roads:

1. Always wear your seat belt.
2. Correct driving lights for road use and using implement connector to power implement lights. Turn signal and warning light usage. (See Electrical and Lighting Operation section.)
3. Locking brake pedals together, see Steering and Brake Operation section.
4. Transmission operation, see Transmission Operation section.
5. Correct MFWD setting for road use, see MFWD and Front Axle Operation section.
6. Disengage differential lock, see Differential and Rear Axle Operation section.
7. Lock rear hitch in transport position, see Hitch and Drawbar Operation section.
8. Lock loader cylinders, see loader operator's manual for more info.
9. Lock SCVs or lock implement cylinders to prevent

accidental engagement, see Selective Control Valve Operation section or implement operator's manual.

10. Clean windows, slow moving machine sign, and lights. Adjust steering wheel, seat, and mirrors. (See Operator's Station Operation section.)
11. Ballast machine correctly, see Ballasting section.
12. Use the foot speed control instead of the hand speed control. (See Engine Operation section.)

MP60050,0000AF4-19-17MAY21

Towing Loads

⚠ CAUTION: Avoid possible injury from losing control while towing a load. Stopping distance increases with speed and weight of towed loads, and on slopes.

Never operate with transmission in neutral position or with clutch disengaged.

Never exceed implement maximum transport speed. Before transporting a towed implement, refer to the implement operator's manual and implement decals to determine the maximum transport speed. Use implement code in the implement operator's manual to determine minimum number of front weights required.

Failure to adhere to implement maximum transport speed or to have correct ballast can result in:

- Loss of control of machine/implement combination.
- Reduced or no ability to stop during braking.
- Implement tire failure.
- Damage to implement structure or components.

Drive slowly enough to maintain safe control. Be alert for skids. Shift to a lower gear for hillsides, rough ground, and sharp turns, especially when transporting heavy equipment.

Machine must be heavy and powerful enough with adequate braking power for towed load. Add ballast to the machine or lighten implement load.

Guidelines for Towing Equipment without Brakes:

- Do not transport at speeds greater than 32 km/h (20 mph).
- Equipment must weigh less than 1.5 times the ballasted machine weight.

Guidelines for Towing Equipment with Brakes:

- If the implement manufacturer does not specify a

maximum transport speed, avoid transport at speeds above 40 km/h (24.8 mph).

- When transporting at speeds up to 40 km/h (24.8 mph), the fully loaded implement must weigh less than 4.5 times machine weight.

GS25068,0005409-19-19SEP18

Come Home Mode

IMPORTANT: The come home feature allows operation of the machine at a limited capacity. If an electrical issue prevents the machine from moving, the operator can engage come home mode to move the machine.

This mode is intended for limited operation at low speeds to move the machine to a location where it can be transported to a repair facility. Extended operation in come home mode could lead to machine damage.

NOTE: Engine speed is limited to 1300 rpm while come home mode is active.

Enter Come Home Mode:

1. Place left-hand reverser in Neutral position.
2. Start engine.
3. The operator must stand up fully and sit back down for the machine to acknowledge operator presence.
4. Remove the F34 fuse from the fuse panel.
5. Come home mode is active. Diagnostic code OIC 523966.31 is present and the transmission indicator on the display flashes.

Operate Machine:

1. Depress clutch.
2. Select a speed and range.

NOTE: Only low speeds are available in come home mode.

3. Place the left-hand reverser in forward or reverse as needed.
4. Release clutch to move machine.
5. Depress clutch pedal and place left-hand reverser in Neutral to stop machine.

Exit Come Home Mode:

1. Shut key switch off.
2. Replace the F34 fuse in the fuse panel.

GS25068,000164E-19-13MAY21

Tow Machine

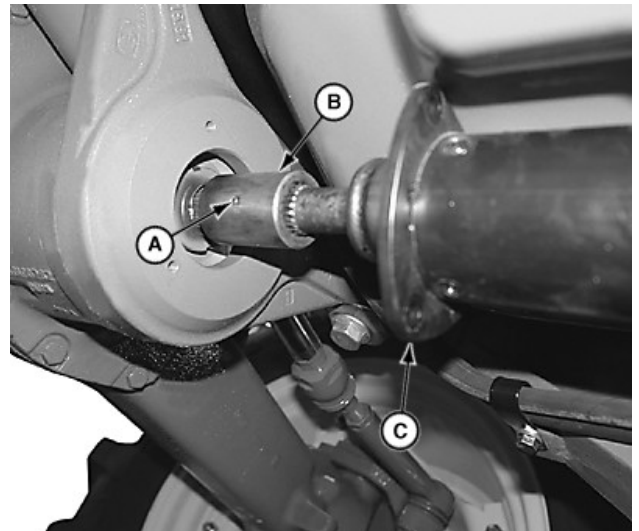

LV14557—UN—03AUG11

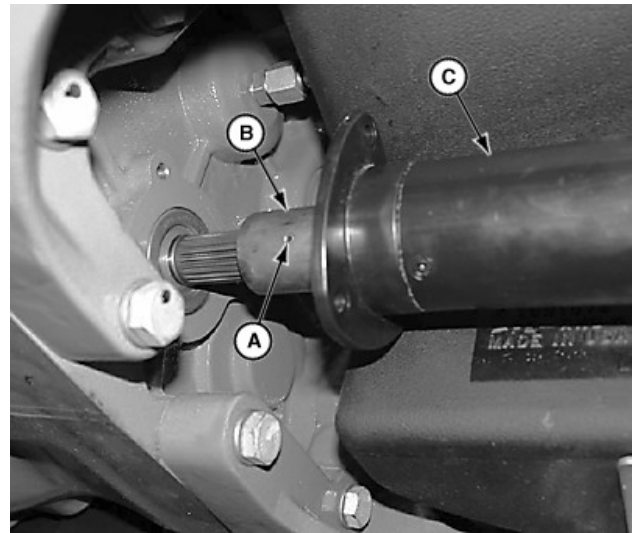

LV14558—UN—03AUG11

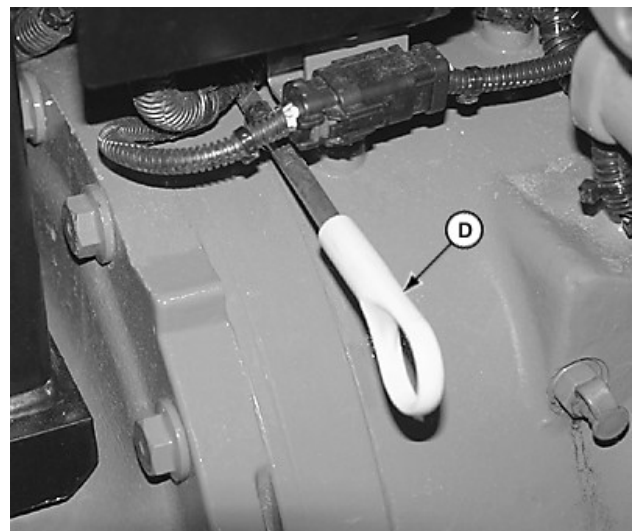

LV14559—UN—03AUG11

- A—Spring Pin
- B—Coupler
- C—Driveshaft Shield

D—Dipstick

CAUTION: Remove MFWD drive shaft if towing machine with front wheels on a carrier. Loss of electrical power or transmission/hydraulic system pressure engages the MFWD and can pull machine off the carrier, even with switch in the DISENGAGED position.

IMPORTANT: To avoid damage to transmission and power train components, **NEVER** attempt to start machine by towing; engine will not start.

1. If equipped with MFWD and towing machine with front wheels on a carrier, remove driveshaft:
 - a. Remove three cap screws and slide driveshaft shield (C) away. Repeat on opposite end.
 - b. Remove spring pin (A) using a punch and hammer.
 - c. While supporting driveshaft, slide coupler (B) toward shield (C) to disengage.
 - d. Remove driveshaft, shields, and couplers.
2. If possible, operate engine above 1250 rpm to provide lubrication, power steering, and power brakes. Have an operator steer and brake machine.
3. If not possible to run engine, add 40 L (10 gal) of transmission/hydraulic oil to transmission. Drain excess oil after transporting.
4. To make sure that differential lock is not engaged, tap brake pedals .
5. Disengage PTO and move range and speed shift levers to Neutral.
6. If equipped with a left-hand reverser, move lever to Neutral.
7. Do not tow a machine faster than 8 km/h (5 mph). Do not exceed 3 km/h (2 mph) for the first 10 minutes at temperatures below freezing.

After Towing

If equipped with MFWD, apply multipurpose grease to couplers and shaft splines, and reinstall driveshaft assembly.

Drain excess transmission/hydraulic oil to return system to normal operating level.

Check oil level with dipstick (D) after draining and again after operating for five minutes.

GS25068,000540A-19-19SEP18

Front Tow Points

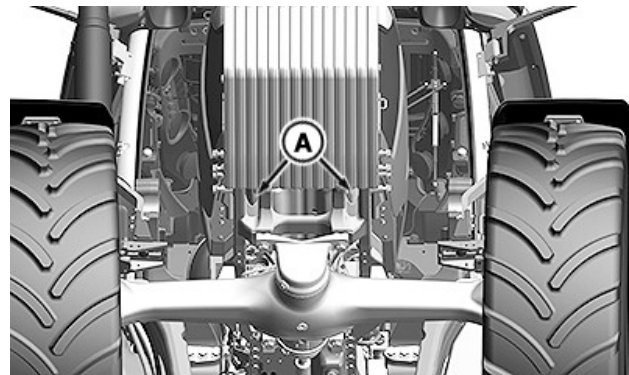

RXA0151018—UN—19JAN16
Oil Pan Tow Points (Weights Installed)

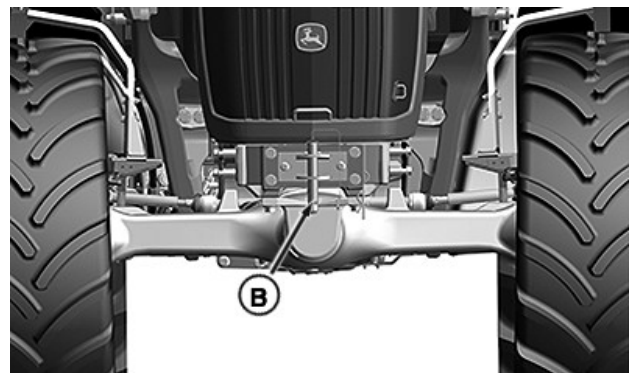

RXA0151020—UN—19JAN16
Front Tow Pin (Without Weight Bracket)

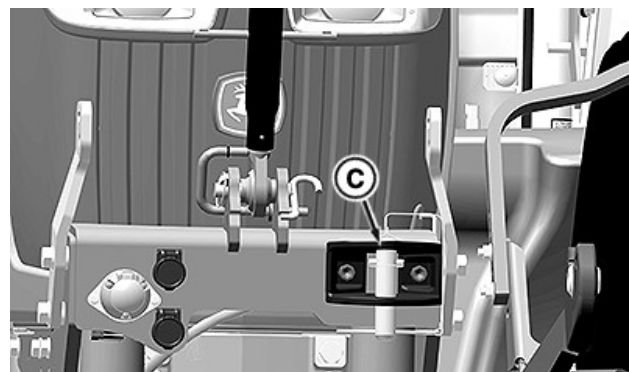

RXA0151069—UN—06DEC16
Front Hitch Tow Pin

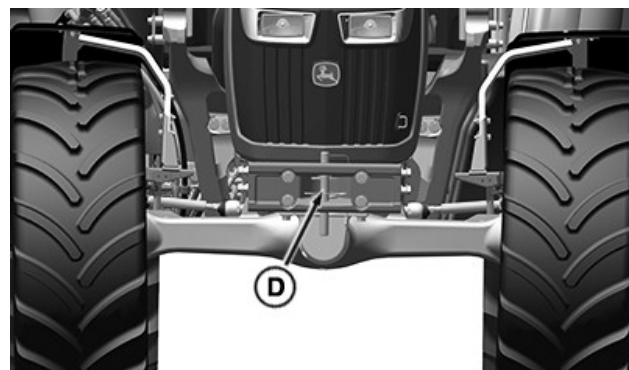

RXA0151311—UN—11NOV16
Front Tow Pin (Weight Bracket Without Weights)

- A—Oil Pan Tow Points
- B—Front Tow Pin
- C—Front Hitch Tow Pin
- D—Front Weight Bracket Tow Pin

CAUTION: Using improper towing devices can result in device failure and personal injury. If towing or freeing a mired machine is required, use pins, clevises, tow straps, or chains which are rated higher than the machine and implement weight. See your John Deere dealer.

Connect towing device to the tow points as necessary. Oil pan tow points (A) can be used on any machine if a chain with hooks on both ends is secured to both points.

DP51502,0002AAF-19-02FEB17

Rear Tow Points

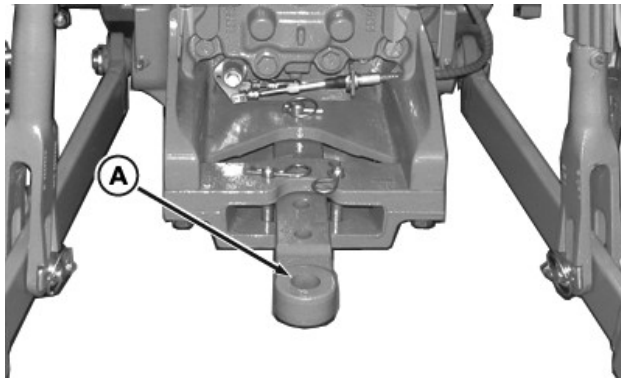

PULV004940—UN—19JUN09

A—Rear Drawbar Tow Point

CAUTION: Using improper towing devices can result in device failure and personal injury. If towing or freeing a mired machine is required, use pins, clevises, tow straps, or chains which are rated higher than the machine and implement weight. See your John Deere dealer.

Connect towing device to the tow points as necessary.

DP51502,0002AB0-19-02FEB17

Machine Storage

IMPORTANT: Anytime machine is not used for several months, use this procedure to minimize corrosion and deterioration. Use an engine storage kit and an extra 0.95 L (1 pt) of corrosion inhibitor. See your John Deere dealer.

IMPORTANT: Long-term storage of Diesel Exhaust Fluid in the DEF tank (over 12 months) is not recommended. If long-term storage is necessary, test DEF before operating engine. (See Fuel, Lubricants, and Coolants section.)

NOTE: Whenever possible, store machine in a building or under a roof to avoid damage resulting from prolonged exposure to the elements.

Perform the following steps to place machine into storage:

1. Service air cleaner, see Air, Fuel, Coolant, and Exhaust Maintenance section.
2. Change engine oil and filter, see Engine Maintenance section.
3. If coolant has not been changed within the last 2 years, flush cooling system. (See your John Deere dealer.) Add 50% antifreeze/water mixture. Test coolant for adequate cold-weather protection.
4. Add 0.5 L (16 oz) of corrosion inhibitor to engine at the oil fill cap.
5. Add 0.25 L (9 oz) of corrosion inhibitor to the transmission/hydraulic reservoir at the oil fill cap.
6. Drain fuel and add back 4 L (1 gal) of fuel. Then add 0.5 L (16 oz) of corrosion inhibitor to fuel tank.
7. Depress clutch and start engine. Run engine until it reaches operating temperature. Also raise and lower front and rear hitches several times. When done, fully lower rear hitch and raise front hitch to retract cylinders.
8. Shut off engine.
9. Remove air intake hose at the manifold. Pour 0.1 L (3 oz) inhibitor into manifold and replace hose.
10. Disconnect crankshaft position sensor wiring connector. (Preventing engine from starting while engaging the starter.)
11. Pull hand speed control back to low idle position. Crank engine only a few revolutions.
12. Release tension on auxiliary drive belts. Remove belt from the air conditioner pulley and fan pulley.
13. Remove and clean battery. Store in a cool, dry place. Keep battery charged. Disconnect battery ground cable for short-term storage periods (30 to 90 days). (See Electrical and Lighting Maintenance section.)
14. Coat exposed metal surfaces, such as steering cylinder rods, if extended, with grease or a corrosion inhibitor.
15. Seal air inlets, exhaust, crankcase fill cap, fuel tank cap, radiator overflow hose, and transmission and hydraulic system fill cap using plastic bags and tape.
16. Protect tires from heat and sunlight:
 - Raise tires off the ground (move machine once a month if tires are not raised off the ground).
 - Cover wheels with waterproof tarpaulin.

- Avoid storing at temperatures greater than 29°C (85°F).
 - Avoid direct sunlight.
17. Thoroughly clean machine. Touch up any painted surfaces that are scratched or chipped.
 18. Wax entire machine.
 19. If machine is stored outside, follow additional precaution: Cover instrument panel, controls, and seat with sheets of material or cardboard, or cover entire machine with waterproof material to protect against sunlight.
 15. Operate air conditioning system at low idle for 2 minutes.
 16. Check all other system functions.

GS25068,000540C-19-19SEP18

MP60050,0000AF5-19-17MAY21

Remove Machine from Storage

IMPORTANT: If machine has been stored over 12 months, test DEF before operating engine. (See Fuel, Lubricants, and Coolants section.)

To remove machine from storage, perform the following steps:

1. Remove all coverings placed in or on machine while storing it.
2. Inspect tires and check tire inflation pressure, see Wheels and Tires Maintenance section.
3. Unseal all openings sealed before storing.
4. Charge and install battery.
5. Install auxiliary belt drive on the air compressor pulley and fan pulley.
6. Check levels of engine oil, transmission/hydraulic oil, engine coolant, and diesel exhaust fluid (DEF). Add if necessary.
7. To purge any moisture condensation that has collected, drain a small amount of fuel from the fuel tank.
8. Fill fuel tank.
9. Check all instruments and indicators by turning ignition switch to ON position.
10. Connect crankshaft position sensor connector.
11. Crank engine for a few revolutions.

IMPORTANT: Do not operate the starter more than 20 seconds at a time, and wait at least 2 minutes for starter to cool before trying again.

12. Start the engine.
13. Operate engine at low idle for some time.
14. Check air conditioning system.

Maintenance Intervals

Maintain Daily Before Start-Up

IMPORTANT: Do not operate when oil level is below lower mark on dipstick.

For any off level operation, engine oil must be maintained at the FULL mark to avoid engine damage.

1. Check engine oil level. (See Engine Maintenance section for procedure.)
2. Raise hood. Clean dust unloading valve. (See Air, Fuel, Coolant, and Exhaust Maintenance section for procedure.)
3. Check transmission/hydraulic oil. (See Hydraulics Maintenance for procedure.)
4. Inspect machine for damage. Repair as needed before operation.
 - Debris around cooling package
 - Exhaust and engine areas
 - Mud and field debris buildup
 - Low tire pressure
 - Loose hardware
5. If operating in wet or muddy conditions, lubricate the following at the 10-hour service interval with multipurpose grease:
 - Front axle pivot pin
 - Rear axle bearings
 - Front and rear hitch

GS25068,000540D-19-19SEP18

Maintenance Intervals

Maintenance Interval Chart

Item	Daily or Every 10 Hours	Weekly or Every 50 Hours	First 100 Hours	Every 250 Hours	Every 500 Hours
Check Engine Oil Level	•				
Clean Air Filter Dust Unloading Valve	•				
Drain Water and Sediment from Fuel Filter	•				
Check Coolant Level		•			
Check Transmission/Hydraulic System Oil Level		•			
Inspect Tires		•			
Check Tire Inflation Pressure		•			
Lubricate MFWD Axle Trunnion		•			
Lubricate Front Hitch		•			
Lubricate Rear Hitch		•			
Check and Tighten Air Intake System and Coolant System Hose Clamps			•		
Change Transmission/Hydraulic Filter			•		•
Check Hitch and Drawbar for Excessive Wear				•	
Change Activated Carbon Filter				•	
Lubricate Draft Sensing Shaft Seal				•	
Check Neutral Start System					•
Change Engine Oil and Filter					•
Change Fuel Filters					•
Change MFWD Axle Wheel Hub and Housing Oil					•
Clean Cab Air Filters					•
Clean Open Crankcase Vent					•
Lubricate Rear Axle Bearings					•

Maintenance Chart — Daily (10 Hours) to 500 Hours

Item	Every 1000 Hours Or Annually	Every 1500 Hours	Every 3000 Hours or 3 Years	Every 4500 Hours or 5 Years	Every 6000 Hours or 6 Years
Check Battery and Connections	•				
Check Coolant Properties	•				
Check Seat Belts	•				
Check Fan Belt Tensioner	•				
Change Fan Belt	•				
Change Front PTO Oil	•				
Clean Fuel Tank Vent Filter	•				
Service Air Cleaner Elements	•				
Lubricate Exchangeable 540/1000 rpm PTO Shaft	•				
Change Open Crankcase Ventilation Filter		•			
Change Transmission/Hydraulic Oil and Filter		•			
Adjust Engine Valve Clearance ^a			•		
Change Transmission Dampener ^a				•	
Change Diesel Exhaust Fluid (DEF) Dosing Unit Filter			•		
Change Diesel Exhaust Fluid (DEF) Tank Header Suction Screen				•	
Change Thermostat					•
Drain and Replace Coolant					•

Maintenance Chart — 1000 Hours to 6000 Hours

^aSee your John Deere dealer for service.

Fuels, Lubricants, and Coolants

Alternative and Synthetic Lubricants

Conditions in certain geographical areas may require lubricant recommendations different from those printed in this manual.

Some John Deere brand coolants and lubricants may not be available in your location.

Consult your John Deere dealer to obtain information and recommendations.

Synthetic lubricants may be used if they meet the performance requirements as shown in this manual.

The temperature limits and service intervals shown in this manual apply to John Deere branded fluids or fluids that have been tested and/or approved for use in John Deere equipment.

Re-refined base stock products may be used if the finished lubricant meets the performance requirements.

DX,ALTER-19-13JAN18

Diesel Engine Coolant (engine with wet sleeve cylinder liners)

Failure to follow applicable coolant standards and drain intervals can result in severe engine damage that may not be covered under warranty. Warranties, including the emissions warranty, are not conditioned on the use of John Deere coolants, parts, or service.

Preferred Coolants

The following pre-mix engine coolants are preferred:

- John Deere COOL-GARD™ II
- John Deere COOL-GARD II PG

COOL-GARD II pre-mix coolant is available in several concentrations with different freeze protection limits as shown in the following table.

COOL-GARD II Pre-Mix	Freeze Protection Limit
COOL-GARD II 20/80	-9°C (16°F)
COOL-GARD II 30/70	-16°C (3°F)
COOL-GARD II 50/50	-37°C (-34°F)
COOL-GARD II 55/45	-45°C (-49°F)
COOL-GARD II PG 60/40	-49°C (-56°F)
COOL-GARD II 60/40	-52°C (-62°F)

Not all COOL-GARD II pre-mix products are available in all countries.

Use COOL-GARD II PG when a non-toxic coolant formulation is required.

Additional Recommended Coolants

The following engine coolant is also recommended:

COOL-GARD is a trademark of Deere & Company

- John Deere COOL-GARD II Concentrate in a 40—60% mixture of concentrate with quality water.

IMPORTANT: When mixing coolant concentrate with water, do not use less than 40% or greater than 60% concentration of coolant. Less than 40% gives inadequate additives for corrosion protection. Greater than 60% can result in coolant gelation and cooling system problems.

Other Coolants

Other ethylene glycol or propylene glycol base coolants may be used if they meet the following specification:

- Pre-mix coolant meeting ASTM D6210 requirements
- Is formulated with a 2-ethylhexanoic acid (2-EHA) free additive package
- Coolant concentrate meeting ASTM D6210 requirements in a 40—60% mixture of concentrate with quality water

If coolant meeting one of these specifications is unavailable, use a coolant concentrate or pre-mix coolant that has a minimum of the following chemical and physical properties:

- Provides cylinder liner cavitation protection according to either the John Deere Cavitation Test Method or a fleet study run at or above 60% load capacity
- Is formulated with a nitrite-free additive package
- Is formulated with a 2-ethylhexanoic acid (2-EHA) free additive package
- Protects the cooling system metals (cast iron, aluminum alloys, and copper alloys such as brass) from corrosion

Water Quality

Water quality is important to the performance of the cooling system. Deionized or demineralized water is recommended for mixing with ethylene glycol and propylene glycol base engine coolant concentrate.

Coolant Drain Intervals

Drain and flush the cooling system and refill with fresh coolant at the indicated interval, which varies with the coolant used.

When COOL-GARD II or COOL-GARD II PG is used, the drain interval is 6 years or 6000 hours of operation.

If a coolant other than COOL-GARD II or COOL-GARD

If PG is used, reduce the drain interval to 2 years or 2000 hours of operation.¹

IMPORTANT: Do not use cooling system sealing additives or antifreeze that contains sealing additives.

Do not mix ethylene glycol and propylene glycol base coolants.

Do not use coolants that contain nitrites.

DX,COOL3-19-25AUG20

Operating in Warm Temperature Climates

John Deere engines are designed to operate using recommended engine coolants.

Always use a recommended engine coolant, even when operating in geographical areas where freeze protection is not required.

IMPORTANT: Water may be used as coolant in emergency situations only.

Foaming, hot surface aluminum and iron corrosion, scaling, and cavitation occur when water is used as the coolant, even when coolant conditioners are added.

Drain cooling system and refill with recommended engine coolant as soon as possible.

DX,COOL6-19-17FEB20

John Deere COOL-GARD™ II Coolant Extender

Some coolant additives gradually deplete during engine operation. For COOL-GARD™ II pre-mix and COOL-GARD II Concentrate, replenish coolant additives between drain intervals by adding COOL-GARD II Coolant Extender.

COOL-GARD II Coolant Extender should not be added unless indicated by COOL-GARD II Test Strips. These test strips provide a simple, effective method to check the freeze point, additive levels, and pH of your engine coolant.

Test the coolant solution at intervals of 12 months and whenever excessive coolant is lost through leaks or overheating.

COOL-GARD is a trademark of Deere & Company

¹ Coolant analysis may extend the service interval of other "Coolants" to a maximum not to exceed the interval of Cool-Gard II coolants. Coolant analysis means taking a series of coolant samples at 1000 hour increments beyond the normal service interval until either the data indicate the end of useful coolant life or the maximum service interval of Cool-Gard II is reached.

IMPORTANT: Do not use COOL-GARD II Test Strips with COOL-GARD II PG.

COOL-GARD II Coolant Extender is a chemically matched additive system for use with all COOL-GARD II coolants. COOL-GARD II Coolant Extender is not intended for use with nitrite-containing coolants.

IMPORTANT: Do not add a supplemental coolant additive when the cooling system is drained and refilled with any of the following:

- John Deere COOL-GARD II
- John Deere COOL-GARD II PG

The use of non-recommended supplemental coolant additives can result in additive drop-out, gelation of the coolant, or corrosion of cooling system components.

Add the recommended concentration of COOL-GARD II Coolant Extender. DO NOT add more than the recommended amount.

DX,COOL16-19-15MAY13

Water Quality for Mixing with Coolant Concentrate

Engine coolants are a combination of three chemical components: ethylene glycol (EG) or propylene glycol (PG) antifreeze, inhibiting coolant additives, and quality water.

Water quality is important to the performance of the cooling system. Deionized or demineralized water is recommended for mixing with ethylene glycol and propylene glycol base engine coolant concentrate.

All water used in the cooling system should meet the following minimum specifications for quality:

Chlorides	<40 mg/L
Sulfates	<100 mg/L
Total solids	<340 mg/L
Total dissolved hardness	<170 mg/L
pH	5.5—9.0

IMPORTANT: Do not use bottled drinking water because it often contains higher concentrations of total dissolved solids.

Freeze Protection

The relative concentrations of glycol and water in the engine coolant determine its freeze protection limit.

Ethylene Glycol	Freeze Protection Limit
40%	-24°C (-12°F)
50%	-37°C (-34°F)
60%	-52°C (-62°F)

Ethylene Glycol	Freeze Protection Limit
Propylene Glycol	Freeze Protection Limit
40%	-21°C (-6°F)
50%	-33°C (-27°F)
60%	-49°C (-56°F)

DO NOT use a coolant-water mixture greater than 60% ethylene glycol or 60% propylene glycol.

DX,COOL19-19-13JAN18

Testing Coolant Freeze Point



TS1732—UN—04SEP13

SERVICEGARD™ Part Number 75240

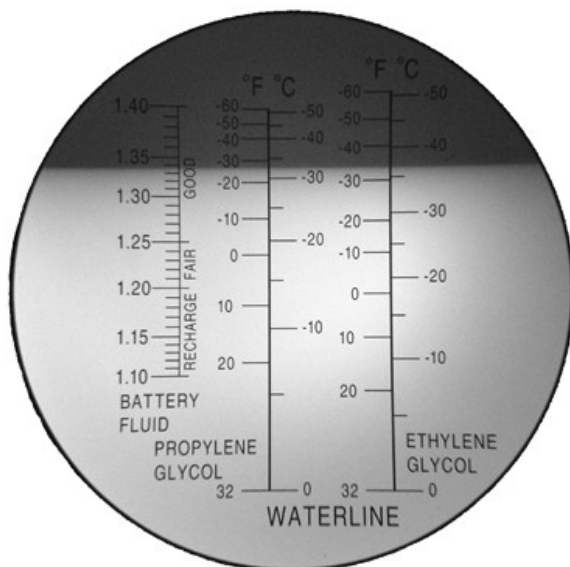

TS1733—UN—04SEP13

Image with a Drop of 50/50 Coolant Placed on the Refractometer Window

The use of a handheld coolant refractometer is the quickest, easiest, and most accurate method to determine coolant freeze point. This method is more accurate than a test strip or a float-type hydrometer which can produce poor results.

A coolant refractometer is available through your

John Deere dealer under the SERVICEGARD™ tool program. Part number 75240 provides an economical solution to accurate freeze point determination in the field.

To use this tool:

1. Allow cooling system to cool to ambient temperatures.
2. Open radiator cap to expose coolant.
3. With the included dropper, collect a small coolant sample.
4. Open the lid of the refractometer, place one drop of coolant on the window and close the lid.
5. Look through the eyepiece and focus as necessary.
6. Record the listed freeze point for the type of coolant (ethylene glycol coolant or propylene glycol) being tested.

DX,COOL,TEST-19-13JUN13

Diesel Exhaust Fluid (DEF) — Use in Selective Catalytic Reduction (SCR) Equipped Engines

In order to maintain the emissions performance of the engine, it is essential to use and refill DEF in accordance with the specification.

Diesel exhaust fluid (DEF) is a high purity liquid that is injected into the exhaust system of engines equipped with selective catalytic reduction (SCR) systems. Maintaining the purity of DEF is important to avoid malfunctions in the SCR system. Engines requiring DEF shall use a product that meets the requirements for aqueous urea solution 32 (AUS 32) according to ISO 22241-1.

The use of John Deere Diesel Exhaust Fluid is recommended. John Deere Diesel Exhaust Fluid is available at your John Deere dealer in a variety of package sizes to suit your operational needs.

If John Deere Diesel Exhaust Fluid is not available, use DEF that is certified by the American Petroleum Institute (API) Diesel Exhaust Fluid Certification Program or by the AdBlue™ Diesel Exhaust Fluid Certification Program. Look for the API certification symbol or the AdBlue™ name on the container.



RG30211—UN—08MAR18

SERVICEGARD is a trademark of Deere & Company
AdBlue is a trademark of VDA, the German Association of the Automotive Industry.

In some cases, DEF is referred to by one or more of these names:

- Urea
- Aqueous Urea Solution 32
- AUS 32
- AdBlue™
- NOx Reduction Agent
- Catalyst Solution

DX,DEF-19-13JAN18

Disposal of Diesel Exhaust Fluid (DEF)

Although there is little issue with minor spillage of DEF on the ground, large amounts of DEF should be contained. If large spills occur, contact local environmental authorities for assistance with clean-up.

If a substantial quantity of DEF is not within specification, contact the DEF supplier for assistance with disposal. Do not dump substantial quantities of DEF onto the ground or send DEF to wastewater treatment facilities.

DX,DEF,DISPOSE-19-13JUN13

Refilling Diesel Exhaust Fluid (DEF) Tank



TS1731—UN—23AUG13

⚠ CAUTION: Avoid contact with eyes. In case of contact, immediately flush eyes with large amounts of water for a minimum of 15 minutes. Reference the Materials Safety Data Sheet (MSDS) for additional information.

Do not ingest DEF. In the event DEF is ingested, contact a physician immediately. Reference the Materials Safety Data Sheet (MSDS) for additional information.

IMPORTANT: Use only distilled water to rinse components that are used to deliver DEF. Tap water can contaminate DEF. If distilled water is not available, rinse with clean tap water, then thoroughly rinse with ample amounts of DEF.

If DEF is spilled or contacts any surface other than the storage tank, immediately clean the surface with clear water. DEF is corrosive to painted and unpainted metallic surfaces and can distort some plastic and rubber components.

If DEF is filled into engine fuel tank or other fluid compartment, do not operate engine until system is properly purged of DEF. Contact your John Deere dealer immediately to determine how to clean and purge the system.

Reasonable care should be taken when refilling the DEF tank. Ensure that the DEF tank cap area is free of debris before removing the cap. Seal containers of DEF between use to prevent contamination and evaporation.

Avoid splashing DEF and do not allow DEF to come into contact with skin, eyes, or mouth.

DEF is not harmful to handle, but DEF can be corrosive to materials such as steel, iron, zinc, nickel, copper, aluminum, and magnesium. Use suitable containers to transport and store DEF. Containers made of polyethylene, polypropylene, or stainless steel are recommended.

Avoid prolonged contact with skin. In case of accidental contact, wash skin immediately with soap and water.

Keep anything used to store or dispense DEF clean of dirt and dust. Wash and rinse containers or funnels thoroughly with distilled water to remove contaminants.

If an unapproved fluid, such as diesel fuel or coolant is added to the DEF tank, contact your John Deere dealer immediately to determine how to clean and purge the system.

If water has been added to the DEF tank, a tank cleaning is necessary. See Cleaning DEF Tank in this manual. After refilling the tank, check the DEF concentration. See Testing Diesel Exhaust Fluid (DEF).

The operator must maintain appropriate DEF levels at all times. Check the DEF level daily and refill the tank as needed. The filling port is identified by a blue colored cap embossed with the following DEF symbol.

DX,DEF,REFILL-19-15JUL20

Storing Diesel Exhaust Fluid (DEF)

⚠ CAUTION: Avoid contact with eyes. In case of contact, immediately flush eyes with large amounts of water for a minimum of 15 minutes. Reference the Materials Safety Data Sheet (MSDS) for additional information.

Do not ingest DEF. In the event DEF is ingested, contact a physician immediately. Reference the Materials Safety Data Sheet (MSDS) for additional information.

IMPORTANT: It is unlawful to tamper with or remove any component of the aftertreatment system. Do not use DEF that does not meet the required specifications or operate the engine with no DEF.

Never attempt to create DEF by mixing agricultural grade urea with water. Agricultural grade urea does not meet the necessary specifications and can damage the aftertreatment system.

Do not add any chemicals or additives to DEF in an effort to prevent freezing. Any chemicals or additives added to DEF can damage the aftertreatment system.

Never add water or any other fluid in place of, or in addition to DEF. Operating with a modified DEF or using an unapproved DEF can damage the aftertreatment system.

Storage information provided below is for reference and is to be used as a guideline only.

It is preferred to store DEF out of extreme ambient temperatures. DEF freezes at -11°C (12°F). Exposure to temperatures greater than 30°C (86°F) can degrade DEF over time. Do not store DEF in direct sunlight.

Dedicated DEF storage containers must be sealed between uses to prevent evaporation and contamination. Containers made of polyethylene, polypropylene, or stainless steel are recommended to transport and store DEF.

Ideal conditions for storage of DEF are:

- Store at temperatures between -5°C and 30°C (23°F and 86°F)
- Store in dedicated containers sealed to avoid contamination and evaporation

Under these conditions, DEF is expected to remain useable for a minimum of 18 months. Storing DEF at higher temperatures can reduce its useful life by approximately 6 months for every 5°C (9°F) temperature above 30°C (86°F).

If unsure how long or under what conditions DEF has been stored, test DEF. See Testing Diesel Exhaust Fluid (DEF).

Long-term storage in the DEF tank (over 12 months) is not recommended. If long-term storage is necessary, test DEF prior to operating engine. See Testing Diesel Exhaust Fluid (DEF).

It is recommended to purchase DEF in quantities that will be consumed within 12 months.

DX,DEF,STORE-19-15JUL20

Testing Diesel Exhaust Fluid (DEF)

IMPORTANT: Using DEF with the correct concentration is critical to engine and aftertreatment system performance. Extended storage and other conditions can adversely alter the DEF concentration.

If DEF quality is questionable, draw a sample out of the DEF tank or storage tank into a clear container. DEF must be crystal clear with a light ammonia smell. If DEF appears cloudy, has a colored tint, or has a profound ammonia smell, it is likely not within specification. DEF in this condition should not be used. Drain tank, flush with distilled water and refill with new or good DEF. After refilling the tank, check the DEF concentration.

If the DEF passes the visual and smell test, check the DEF concentration with a handheld refractometer calibrated to measure DEF.

DEF concentration should be checked when the engine has been stored for extended periods, or if there is suspicion the engine or packaged DEF fluid has been contaminated with water.

Two approved tools are available through your John Deere dealer:

- JDG11594 Digital DEF Refractometer—A digital tool providing an easy to read concentration measurement
- JDG11684 DEF Refractometer—Low-cost alternative tool providing an analog reading

Follow instructions included with either tool to obtain the measurement.

The correct DEF concentration is 31.8—33.2% urea. If the DEF concentration is not within specification, drain the DEF tank, flush with distilled water and fill with new or good DEF. If packaged DEF is not within specification, dispose of DEF packages and replace with new or good DEF.

DX,DEF,TEST-19-13JUN13

Diesel Engine Oil Service Interval for Operation at High Altitude

To avoid excessive oil degradation and potential engine damage, reduce oil and filter service intervals to 50% of the original recommended values when operating engines at altitudes above **1675 m (5500 ft)**.

Oil analysis may allow longer service intervals.

Use only approved oil types.

Example of Original Hours	Corresponding High Altitude Hours
125	60
150	75

Example of Original Hours	Corresponding High Altitude Hours
175	85
200	100
250	125
275	135
300	150
350	175
375	185
400	200
500	250

DX,ENOIL,SERV,HIALT-19-11NOV14

If John Deere Plus-50™ II engine oil is not available, engine oil meeting one or more of the following may be used:

- API Service Category CK-4
- API Service Category CJ-4
- ACEA Oil Sequence E9
- ACEA Oil Sequence E6

DO NOT use engine oil containing more than 1.0% sulfated ash, 0.12% phosphorus, or 0.4% sulfur.

Multi-viscosity diesel engine oils are preferred.

Diesel fuel quality and fuel sulfur content must comply with all existing emissions regulations for the area in which the engine operates.

IMPORTANT: Use only ultra low sulfur diesel (ULSD) fuel with a maximum sulfur content of 15 mg/kg (15 ppm).

DX,ENOIL14-19-23APR19

Diesel Engine Oil — Interim Tier 4, Final Tier 4, Stage IIIB, Stage IV, and Stage V

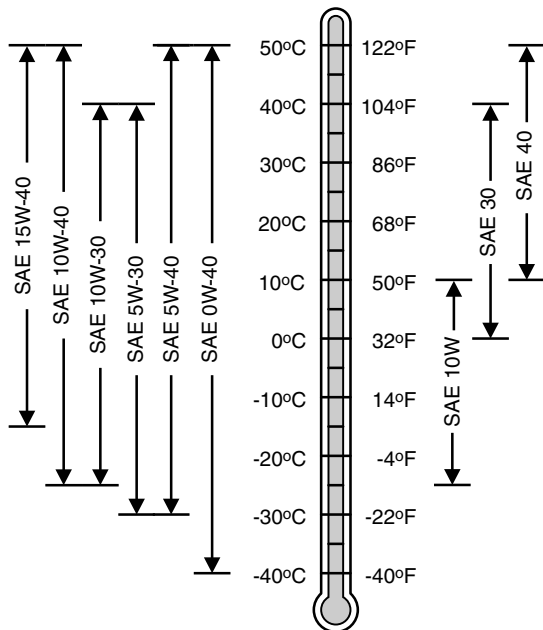

TS1743—UN—25APR19

Oil Viscosities for Air Temperature Ranges

Failure to follow applicable oil standards and drain intervals can result in severe engine damage that might not be covered under warranty. Warranties, including the emissions warranty, are not conditioned on the use of John Deere oils, parts, or service.

Use oil viscosity based on the expected air temperature range during the period between oil changes.

John Deere Plus-50™ II is the recommended engine oil.

Extended service intervals may apply when John Deere Plus-50™ II engine oil is used. Refer to the engine oil drain interval table and consult your John Deere dealer for more information.

Engine Oil and Filter Service Intervals — Interim Tier 4, Final Tier 4, Stage IIIB, Stage IV, and Stage V Engines

Failure to follow applicable oil standards and drain intervals can result in severe engine damage that might not be covered under warranty. Warranties, including the emissions warranty, are not conditioned on the use of John Deere oils, parts, or service.

Recommended oil and filter service intervals are based on a combination of oil pan capacity, type of engine oil and filter used, and sulfur content of the diesel fuel. Actual service intervals also depend on operation and maintenance practices.

Approved Oil Types:

- John Deere Plus-50™ II
- “Other Oils” include API CK-4, API CJ-4, ACEA E9, and ACEA E6

Use oil analysis to evaluate the condition of the oil and to aid in selection of the proper oil and filter service interval. Contact your John Deere dealer or other qualified service provider for more information on engine oil analysis.

Change the oil and oil filter at least once every 12 months even if the hours of operation are fewer than the otherwise recommended service interval.

Diesel fuel sulfur content affects engine oil and filter service intervals. Higher fuel sulfur levels reduce oil and filter service intervals.

Use of diesel fuel with sulfur content less than 15 mg/kg (15 ppm) is **REQUIRED**.

Plus-50 is a trademark of Deere & Company

Engine operation at high altitude decreases oil change intervals. See Diesel Engine Oil Service Interval for Operation at High Altitude for additional information.

NOTE: The 500 hour extended oil and filter change interval is only allowed if all of the following conditions are met:

- Use of diesel fuel with sulfur content less than 15 mg/kg (15 ppm)
- Use of John Deere Plus-50™ II oil
- Use of an approved John Deere oil filter

Engine Oil and Filter Service Intervals	
John Deere Plus-50™ II	500 hours
Other Oils	250 hours
Oil analysis may extend the service interval of "Other Oils" to a maximum not to exceed the interval of Plus-50™ II oils. Oil analysis means taking a series of oil samples at 50-hour increments beyond the normal service interval until either the data indicates the end of useful oil life or the maximum service interval of John Deere Plus-50 II oils is reached.	

IMPORTANT: To avoid engine damage:

- **Reduce oil and filter service intervals by 50% when using biodiesel blends greater than B20. Oil analysis may allow longer service intervals.**
- **Use only approved oil types.**

DX,ENOIL15,IT4,120toMAX-19-13JAN18

John Deere Break-In Plus™ Engine Oil — Interim Tier 4, Final Tier 4, Stage IIIB, Stage IV, and Stage V

New engines are filled at the factory with John Deere Break-In Plus™ Engine Oil. During the break-in period, add John Deere Break-In Plus™ Engine Oil, as needed to maintain the specified oil level.

Operate the engine under various conditions, particularly heavy loads with minimal idling, to help seat engine components properly.

During the initial operation of a new or rebuilt engine, change the oil and filter between a minimum of 100 hours and maximum equal to the interval specified for John Deere Plus-50™ II oil.

After engine overhaul, fill the engine with John Deere Break-In Plus™ Engine Oil.

If John Deere Break-In Plus™ Engine Oil is not available, use an SAE 10W-30 viscosity grade diesel engine oil meeting one of the following:

- API Service Category CK-4
- API Service Category CJ-4

Break-In Plus is a trademark of Deere & Company

- ACEA Oil Sequence E9
- ACEA Oil Sequence E6

If one of these oils is used during the initial operation of a new or rebuilt engine, change the oil and filter between a minimum of 100 hours and a maximum of 250 hours.

IMPORTANT: Do not use any other engine oils during the initial break-in of a new or rebuilt engine.

John Deere Break-In Plus™ Engine Oil can be used for all John Deere diesel engines at all emission certification levels.

After the break-in period, use John Deere Plus-50™ II or other diesel engine oil as recommended in this manual.

DX,ENOIL16-19-13JAN18

Oil Filters

Filtration of oils is critically important for proper operation and lubrication. John Deere brand oil filters have been designed and produced specifically for John Deere applications.

John Deere filters adhere to engineering specifications for quality of the filter media, filter efficiency rating, strength of the bond between the filter media and the element end cap, fatigue life of the canister (if applicable), and pressure capability of the filter seal. Non-John Deere branded oil filters might not meet these key John Deere specifications.

Always change oil filters regularly as specified in this manual.

DX,FILT1-19-11APR11

Fuel Filters

The importance of fuel filtration cannot be overemphasized with modern fuel systems. The combination of increasingly restrictive emission regulations and more efficient engines requires fuel system to operate at much higher pressures. Higher pressures can only be achieved using fuel injection components with very close tolerances. These close manufacturing tolerances have significantly reduced capacities for debris and water.

John Deere brand fuel filters have been designed and produced specifically for John Deere engines.

To protect the engine from debris and water, always change engine fuel filters as specified in this manual.

DX,FILT2-19-14APR11

Plus-50 is a trademark of Deere & Company.

Diesel Fuel

Consult your local fuel distributor for properties of the diesel fuel available in your area.

In general, diesel fuels are blended to satisfy the low temperature requirements of the geographical area in which they are marketed.

Diesel fuels specified to EN 590 or ASTM D975 are recommended. Renewable diesel fuel produced by hydrotreating animal fats and vegetable oils is basically identical to petroleum diesel fuel. Renewable diesel that meets EN 590, ASTM D975, or EN 15940 is acceptable for use at all percentage mixture levels.

Required Fuel Properties

In all cases, the fuel shall meet the following properties:

Cetane number of 40 minimum. Cetane number greater than 47 is preferred, especially for temperatures below -20°C (-4°F) or elevations above 1675 m (5500 ft.).

Cloud Point should be below the expected lowest ambient temperature or **Cold Filter Plugging Point** (CFPP) should be a maximum 10°C (18°F) below the fuel cloud point.

Fuel lubricity should pass a maximum scar diameter of 0.52 mm as measured by ASTM D6079 or ISO 12156-1. A maximum scar diameter of 0.45 mm is preferred.

Diesel fuel quality and sulfur content must comply with all existing emissions regulations for the area in which the engine operates. DO NOT use diesel fuel with sulfur content greater than 10 000 mg/kg (10 000 ppm).

Materials such as copper, lead, zinc, tin, brass and bronze should be avoided in fuel handling, distribution and storage equipment as these metals can catalyze fuel oxidation reactions which can lead to fuel system deposits and plugged fuel filters.

E-Diesel fuel

DO NOT use E-Diesel (Diesel fuel and ethanol blend). Use of E-Diesel fuel in any John Deere machine may void the machine warranty.

 **CAUTION: Avoid severe injury or death due to the fire and explosion risk from using E-Diesel fuel.**

Sulfur Content for Interim Tier 4, Final Tier 4, Stage III B, Stage IV, and Stage V Engines Above 560 kW

- Use ONLY diesel fuel with a maximum of 500 mg/kg (500 ppm) sulfur content.

Sulfur Content for Interim Tier 4, Final Tier 4, Stage III B, Stage IV Engines, and Stage V Engines

- Use ONLY ultra low sulfur diesel (ULSD) fuel with a maximum of 15 mg/kg (15 ppm) sulfur content.

Sulfur Content for Tier 3 and Stage III A Engines

- Use of diesel fuel with sulfur content less than 1000 mg/kg (1000 ppm) is RECOMMENDED.
- Use of diesel fuel with sulfur content 1000—2000 mg/kg (1000—2000 ppm) REDUCES the oil and filter change interval.
- BEFORE using diesel fuel with sulfur content greater than 2000 mg/kg (2000 ppm), contact your John Deere dealer.

Sulfur Content for Tier 2 and Stage II Engines

- Use of diesel fuel with sulfur content less than 2000 mg/kg (2000 ppm) is RECOMMENDED.
- Use of diesel fuel with sulfur content 2000—5000 mg/kg (2000—5000 ppm) REDUCES the oil and filter change interval.²
- BEFORE using diesel fuel with sulfur content greater than 5000 mg/kg (5000 ppm), contact your John Deere dealer.

Sulfur Content for Other Engines

- Use of diesel fuel with sulfur content less than 5000 mg/kg (5000 ppm) is RECOMMENDED.
- Use of diesel fuel with sulfur content greater than 5000 mg/kg (5000 ppm) REDUCES the oil and filter change interval.

IMPORTANT: Do not mix used diesel engine oil or any other type of lubricating oil with diesel fuel.

Improper fuel additive usage may cause damage on fuel injection equipment of diesel engines.

DX,FUEL1-19-01NOV22

Handling and Storing Diesel Fuel

 **CAUTION: Reduce the risk of fire. Handle fuel carefully. DO NOT fill the fuel tank when engine is running. DO NOT smoke while you fill the fuel tank or service the fuel system.**

Fill the fuel tank at the end of each day's operation to prevent water condensation and freezing during cold weather.

Keep all storage tanks as full as practical to minimize condensation.

Ensure that all fuel tank caps and covers are installed properly to prevent moisture from entering. Monitor water content of the fuel regularly.

² See DX,ENOIL12,OEM, DX,ENOIL12,T2,STD, or DX,ENOIL12,T2,EXT for more information on Engine Oil and Filter Service Intervals.

When using biodiesel fuel, the fuel filter may require more frequent replacement due to premature plugging.

Check engine oil level daily prior to starting engine. A rising oil level may indicate fuel dilution of the engine oil.

IMPORTANT: The fuel tank is vented through the filler cap. If a new filler cap is required, always replace it with an original vented cap.

When fuel is stored for an extended period or if there is a slow turnover of fuel, add a fuel conditioner to stabilize the fuel. Keeping the free water drained and treating the bulk fuel storage tank quarterly with a maintenance dose of a biocide will prevent microbial growth. Contact your fuel supplier or John Deere dealer for recommendations.

DX,FUEL4-19-13JAN18

Lubricity of Diesel Fuel

Most diesel fuels manufactured in the United States, Canada, and the European Union have adequate lubricity to ensure proper operation and durability of fuel injection system components. However, diesel fuels manufactured in some areas of the world may lack the necessary lubricity.

IMPORTANT: Make sure the diesel fuel used in your machine demonstrates good lubricity characteristics.

Fuel lubricity should pass a maximum scar diameter of 0.52 mm as measured by ASTM D6079 or ISO 12156-1. A maximum scar diameter of 0.45 mm is preferred.

If fuel of low or unknown lubricity is used, add John Deere Fuel-Protect Diesel Fuel Conditioner (or equivalent) at the specified concentration.

Lubricity of BioDiesel Fuel

Fuel lubricity can improve significantly with BioDiesel blends up to B20 (20% BioDiesel). Further increase in lubricity is limited for BioDiesel blends greater than B20.

DX,FUEL5-19-07FEB14

Testing Diesel Fuel

A fuel analysis program can help to monitor the quality of diesel fuel. The fuel analysis can provide critical data such as calculated cetane index, fuel type, sulfur content, water content, appearance, suitability for cold weather operations, bacteria, cloud point, acid number, particulate contamination, and whether the fuel meets ASTM D975 or equivalent specification.

Contact your John Deere dealer for more information on diesel fuel analysis.

DX,FUEL6-19-13JAN18

Biodiesel Fuel

Biodiesel fuel is comprised of monoalkyl esters of long chain fatty acids derived from vegetable oils or animal fats. Biodiesel blends are biodiesel mixed with petroleum diesel fuel on a volume basis.

Before using fuel containing biodiesel, review the Biodiesel Use Requirements and Recommendations in this Operator's Manual.

Environmental laws and regulations can encourage or prohibit the use of biofuels. Operators should consult with appropriate governmental authorities prior to using biofuels.

John Deere Stage V Engines Operating in the European Union

Where the engine is to be operated within the Union on diesel or non-road gas-oil, a fuel with a FAME content not greater than 8% volume/volume (B8) shall be used.

John Deere Engines with Exhaust Filter Except Stage V Engines Operating in the European Union

Biodiesel blends up to B20 can be used ONLY if the biodiesel (100% biodiesel or B100) meets ASTM D6751, EN 14214, or equivalent specification. Expect a 2% reduction in power and a 3% reduction in fuel economy when using B20.

Biodiesel concentrations above B20 can harm the engine's emission control systems and should not be used. Risks include, but are not limited to, more frequent stationary regeneration, soot accumulation, and increased intervals for ash removal.

John Deere Fuel conditioners or equivalent, which contain detergent and dispersant additives, are required when using biodiesel blends from B10 to B20, and are recommended when using lower biodiesel blends.

John Deere Engines Without Exhaust Filter

Biodiesel blends up to B20 can be used ONLY if the biodiesel (100% biodiesel or B100) meets ASTM D6751, EN 14214, or equivalent specification. Expect a 2% reduction in power and a 3% reduction in fuel economy when using B20.

These John Deere engines can operate on biodiesel blends above B20 (up to 100% biodiesel). Operate at levels above B20 ONLY if the biodiesel is permitted by law and meets the EN 14214 specification (primarily available in Europe). Engines operating on biodiesel blends above B20 might not fully comply with or be permitted by all applicable emissions regulations. Expect up to a 12% reduction in power and an 18% reduction in fuel economy when using 100% biodiesel.

John Deere fuel conditioners or equivalent, which contain detergent and dispersant additives, are required when using biodiesel blends from B10 to B100, and are recommended when using lower biodiesel blends.

Biodiesel Use Requirements and Recommendations

The petroleum diesel portion of all biodiesel blends must meet the requirements of ASTM D975 (US) or EN 590 (EU) commercial standard.

Biodiesel users in the U.S. are strongly encouraged to purchase biodiesel blends from a BQ-9000 Certified Marketer and sourced from a BQ-9000 Accredited Producer (as certified by the National Biodiesel Board). Certified Marketers and Accredited Producers can be found at the following website: <http://www.bq9000.org>.

Biodiesel contains residual ash. Ash levels exceeding the maximums allowed in either ASTM D6751 or EN14214 can result in more rapid ash loading and require more frequent cleaning of the Exhaust Filter (if present).

The fuel filter can require more frequent replacement when using biodiesel fuel, particularly if switching from diesel. Check engine oil level daily prior to starting engine. A rising oil level can indicate fuel dilution of the engine oil. Biodiesel blends up to B20 must be used within 90 days of the date of biodiesel manufacture. Biodiesel blends above B20 must be used within 45 days from the date of biodiesel manufacture.

When using biodiesel blends up to B20, the following must be considered:

- Cold-weather flow degradation
- Stability and storage issues (moisture absorption, microbial growth)
- Possible filter restriction and plugging (usually a problem when first switching to biodiesel on used engines)
- Possible fuel leakage through seals and hoses (primarily an issue with older engines)
- Possible reduction of service life of engine components

Request a certificate of analysis from your fuel distributor to ensure that the fuel is compliant with the specifications provided in this Operator's Manual.

Consult your John Deere dealer for John Deere fuel products to improve storage and performance with biodiesel fuels.

The following must also be considered if using biodiesel blends above B20:

- Possible coking or blocked injector nozzles, resulting in power loss and engine misfire if John Deere fuel additives and conditioners or equivalent containing detergent/dispersants are not used

- Possible crankcase oil dilution (requiring more frequent oil changes)
- Possible lacquering or seizure of internal components
- Possible formation of sludge and sediments
- Possible thermal oxidation of fuel at elevated temperatures
- Possible compatibility issues with other materials (including copper, lead, zinc, tin, brass, and bronze) used in fuel handling, distribution, and storage equipment
- Possible reduction in water separator efficiency
- Possible damage to paint if exposed to biodiesel
- Possible corrosion of fuel injection equipment
- Possible elastomeric seal and gasket material degradation (primarily an issue with older engines)
- Possible high acid levels within fuel system
- Because biodiesel blends above B20 contain more ash, using blends above B20 can result in more rapid ash loading and require more frequent cleaning of the Exhaust Filter (if present)

IMPORTANT: Raw pressed vegetable oils are NOT acceptable for use as fuel in any concentration in John Deere engines. Their use could cause engine failure.

DX,FUEL7-19-13JAN18

Minimizing the Effect of Cold Weather on Diesel Engines

John Deere diesel engines are designed to operate effectively in cold weather.

However, for effective starting and cold-weather operation, a little extra care is necessary. The following information outlines steps that can minimize the effect that cold weather may have on starting and operation of your engine. See your John Deere dealer for additional information and local availability of cold-weather aids.

Use Winter Grade Fuel

When temperatures fall below 0°C (32°F), winter grade fuel (No. 1-D in North America) is best suited for cold-weather operation. Winter grade fuel has a lower cloud point and a lower pour point.

Cloud point is the temperature at which wax begins to form in the fuel. This wax causes fuel filters to plug.

Pour point is the lowest temperature at which movement of the fuel is observed.

NOTE: On average, winter grade diesel fuel has a lower Btu (heat content) rating. Using winter grade fuel may reduce power and fuel efficiency, but should not cause any other engine performance effects. Check the grade of fuel being used before troubleshooting for low-power complaints in cold-weather operation.

Air Intake Heater

An air intake heater is an available option for some engines to aid cold weather starting.

Ether

An ether port on the intake is available to aid cold weather starting.

 **CAUTION: Ether is highly flammable. Do not use ether when starting an engine equipped with glow plugs or an air intake heater.**

Coolant Heater

An engine block heater (coolant heater) is an available option to aid cold weather starting.

Seasonal Viscosity Oil and Proper Coolant Concentration

Use seasonal grade viscosity engine oil based on the expected air temperature range between oil changes and a proper concentration of low silicate antifreeze as recommended. (See DIESEL ENGINE OIL and ENGINE COOLANT requirements in this section.)

Diesel Fuel Cold Flow Additive

Use John Deere Fuel-Protect Diesel Fuel Conditioner (winter formula), which contains anti-gel chemistry, or equivalent fuel conditioner to treat non-winter grade fuel (No. 2-D in North America) during the cold-weather season. This generally extends operability to about 10° C (18°F) below the fuel cloud point. For operability at even lower temperatures, use winter grade fuel.

IMPORTANT: Treat fuel when outside temperature drops below 0°C (32°F). For best results, use with untreated fuel. Follow all recommended instructions on label.

Biodiesel

When operating with biodiesel blends, wax formation can occur at warmer temperatures. Begin using John Deere Fuel-Protect Diesel Fuel Conditioner (winter formula) or equivalent at 5°C (41°F) to treat biodiesel fuels during the cold-weather season. Use B5 or lower blends at temperatures below 0°C (32°F). Use only winter grade petroleum diesel fuel at temperatures below -10°C (14°F).

Winterfronts

Use of fabric, cardboard, or solid winterfronts is not

recommended with any John Deere engine. Their use can result in excessive engine coolant, oil, and charge air temperatures. This can lead to reduced engine life, loss of power and poor fuel economy. Winterfronts may also put abnormal stress on fan and fan drive components potentially causing premature failures.

If winterfronts are used, they should never totally close off the grill frontal area. Approximately 25% area in the center of the grill should remain open at all times. At no time should the air blockage device be applied directly to the radiator core.

Radiator Shutters

If equipped with a thermostatically controlled radiator shutter system, this system should be regulated in such a way that the shutters are completely open by the time the coolant reaches 93°C (200°F) to prevent excessive intake manifold temperatures. Manually controlled systems are not recommended.

If air-to-air aftercooling is used, the shutters must be completely open by the time the intake manifold air temperature reaches the maximum allowable temperature out of the charge air cooler.

For more information, see your John Deere dealer.

DX,FUEL10-19-13JAN18

Supplemental Diesel Fuel Additives

Diesel fuel can be the source of performance or other operational problems for many reasons. Some causes include poor lubricity, contaminants, low cetane number, and a variety of properties that cause fuel system deposits. These and others are referenced in other sections of this Operator's Manual.

To optimize engine performance and reliability, closely follow recommendations on fuel quality, storage, and handling, which are found elsewhere in this Operator's Manual.

To further aid in maintaining performance and reliability of the engine's fuel system, John Deere has developed a family of fuel additive products for most global markets. The primary products include Fuel-Protect Diesel Fuel Conditioner (full feature conditioner in winter and summer formulas) and Fuel-Protect Keep Clean (fuel injector deposit removal and prevention). Availability of these and other products varies by market. See your local John Deere dealer for availability and additional information about fuel additives that might be right for your needs.

DX,FUEL13-19-07FEB14

Multipurpose Extreme Pressure (EP) Grease

IMPORTANT: For automated lubrication systems different ambient air temperatures need to be considered.

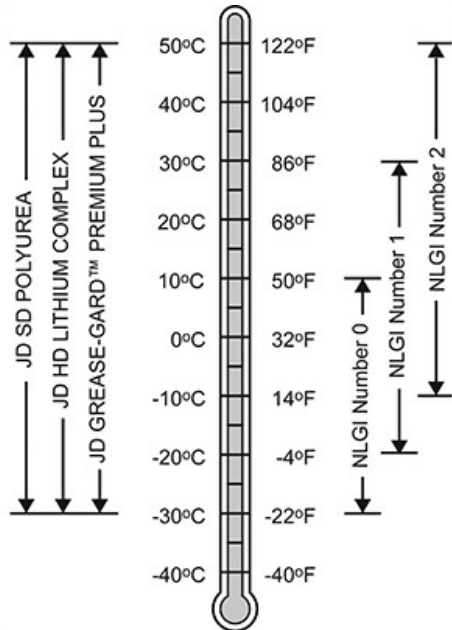

RG30199—UN—08MAR18

Greases for Air Temperature Ranges

Use grease based on NLGI consistency numbers and the expected air temperature range during the service interval.

John Deere SD Polyurea Grease is preferred.

The following greases are also recommended:

- John Deere HD Lithium Complex Grease
- John Deere Grease-Gard™ Premium Plus

Other greases may be used if they meet the following:

- NLGI Performance Classification GC-LB
- ISO-L-X-BDHB 2 or DIN KP 2 N-10 Lithium Complex, Non-Synthetic Base Oil (100 to 220 mm²/s @ 40°C)

IMPORTANT: Some types of thickeners, base oils, and additives used in greases are not compatible with others. Mixing greases should be avoided. Consult your grease supplier before mixing different types of grease.

DX,GREA1-19-13JAN18

Mixing of Lubricants

In general, avoid mixing different brands or types of oil.

Grease-Gard is a trademark of Deere & Company

Oil manufacturers blend additives in their oils to meet certain specifications and performance requirements.

Mixing different oils can interfere with the proper functioning of these additives and degrade lubricant performance.

Consult your John Deere dealer to obtain specific information and recommendations.

DX,LUBMIX-19-18MAR96

Lubricant Storage

Your equipment can operate at top efficiency only when clean lubricants are used.

Use clean containers to handle all lubricants.

Store lubricants and containers in an area protected from dust, moisture, and other contamination. Store containers on their side to avoid water and dirt accumulation.

Make certain that all containers are properly marked to identify their contents.

Properly dispose of all old containers and any residual lubricant they may contain.

DX,LUBST-19-11APR11

Oilscan™ and CoolScan™

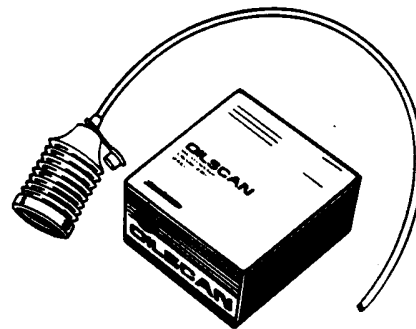

T6828AB—UN—15JUN89

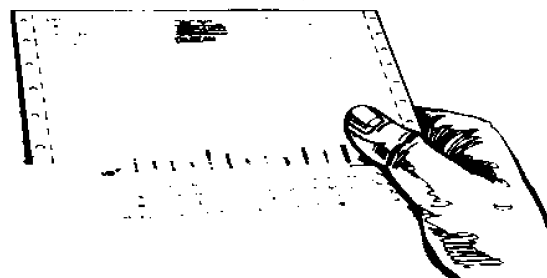

T6829AB—UN—26AUG11

Oilscan™ and CoolScan™ are John Deere sampling programs to help you monitor machine performance and identify potential problems before they cause serious damage.

Oil and coolant samples should be taken from each system before its recommended change interval.

Check with your John Deere dealer for the availability of Oilscan™ and CoolScan™ kits.

DX,OILSCAN-19-13SEP11

Transmission, Steering, Brake, Hydraulic, and Gear Case Oil

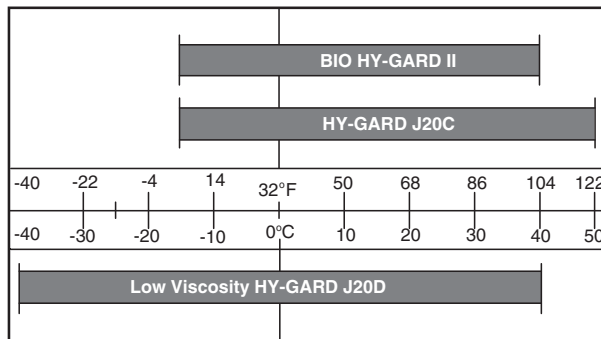

RXA0171623—UN—21OCT19

Oils for Air Temperature Ranges

Use oil viscosity based on the expected air temperature range during the period between oil changes.

The following oils are preferred:

- John Deere Hy-Gard
- John Deere Low Viscosity Hy-Gard

Other oils may be used if they meet one of the following:

- John Deere Standard JDM J20C
- John Deere Standard JDM J20D

Use John Deere Bio Hy-Gard II oil when a biodegradable fluid is required.³

DP51502,0000EC2-19-21APR21

Oilscan is a trademark of Deere & Company
CoolScan is a trademark of Deere & Company

³ Bio Hy-Gard II meets or exceeds the minimum biodegradability of 80% within 21 days according to CEC-L-33-T-82 test method. Bio Hy-Gard II should not be mixed with mineral oils, because this reduces the biodegradability and makes proper oil recycling impossible.

As Required Maintenance

Service As Required

NOTE: Maintain machine as required and as often as necessary. For maintenance items, see the relevant maintenance sections.

Maintenance Item	Maintenance Section
Paint and Finish Care	As Required Maintenance
Wash Machine	As Required Maintenance
General Control and Instrument Maintenance	Controls and Instruments Maintenance
Break-In Checks	Engine Maintenance
Check Engine and Exhaust Compartments for Debris	Air, Fuel, Coolant, and Exhaust Maintenance
Clean Diesel Particulate Filter (DPF)	Air, Fuel, Coolant, and Exhaust Maintenance
Clean Diesel Exhaust Fluid (DEF) Tank	Air, Fuel, Coolant, and Exhaust Maintenance
Drain Diesel Exhaust Fluid (DEF) Tank	Air, Fuel, Coolant, and Exhaust Maintenance
Clean Grille Screens and Cooling Package	Air, Fuel, Coolant, and Exhaust Maintenance
Bleed Fuel System	Air, Fuel, Coolant, and Exhaust Maintenance
Use Booster Battery or Charger	Electrical Maintenance
Access and Replace Battery	Electrical Maintenance
Replace Fusible Link	Electrical Maintenance
Replace Fuses	Electrical Maintenance
Replace Halogen Headlight Bulb	Electrical Maintenance
Replace LED Headlight	Electrical Maintenance
Headlight Adjustment	Electrical Maintenance
Replace Loader Headlight Bulb	Electrical Maintenance
Replace Bucket Light	Electrical Maintenance
Replace Tail/Turn/Brake Light Bulb	Electrical Maintenance
Replace Warning Light Bulb	Electrical Maintenance
Replace Halogen Worklight Bulb	Electrical Maintenance
Replace LED Worklight	Electrical Maintenance
Replace LED Beacon Light	Electrical Maintenance
Replace Dome Light Bulb	Electrical Maintenance
Replace Map Light Bulb	Electrical Maintenance
Replace Right-Hand Console Light Bulb	Electrical Maintenance
Check Transmission Park System	Transmission Maintenance
Adjust PTO Speed Shift Lever ^a	Power Take-Off (PTO) Maintenance
Check Manual Brakes	Steering and Brakes Maintenance
Adjust Mechanical SCV Cables ^a	Selective Control Valve Maintenance
Empty SCV Oil Collection Tank	Selective Control Valve Maintenance
Tighten Wheel Bolts Correctly	Wheels and Tires Maintenance
Tighten Wheel Bolts—MFWD Axle	Wheels and Tires Maintenance
Tighten Wheel Bolts—Rear Axle	Wheels and Tires Maintenance
Check Air Conditioning System	Operator's Station Maintenance
Change Wiper Blade	Operator's Station Maintenance
Keep Cab Protection System Installed Properly	Operator's Station Maintenance

^aSee your John Deere dealer for service.

GS25068,000157A-19-19APR21

Paint and Finish Care

IMPORTANT: Do not use strong soaps, chemical detergents, or cleaning agents containing acids, caustics, or abrasives. It is best to use commercially available car wash (non-detergent) products which do not remove protective wax applied to the paint finish.

- Wash machine regularly, particularly if it has been exposed to herbicides, pesticides, road salt, or other chemical agents.
- Do not wash machine in direct sunlight.
- Rinse all cleaning agents away promptly and do not allow to dry on painted surface.
- Waxing machine occasionally is recommended to remove residue from and further protect paint finish. Do not use waxes containing abrasive compounds.
- Inspect paint surface during washing or waxing for chips and scratches. Repaint any areas where paint has been damaged.

Your John Deere dealer has a full line of cleaners, waxes, and touch-up paints compatible with your equipment to help enhance the paint finishes.

GS25068,0005410-19-19SEP18

Wash Machine

IMPORTANT: Cab seals are designed to be rain proof and are not able to withstand high water pressure during washing. Using a pressure washer or high pressure hose causes water ingress into the cab.

- Avoid using high-pressure water around roof seals, door seals, and vents.
- Directing pressurized water at electronic/electrical components or connectors, bearings and hydraulic seals, fuel injection pumps, exhaust outlet or other sensitive parts and components can cause product malfunctions.
- Reduce pressure and wash at a 45 to 90 degree angle.
- Do not use water at temperatures over 50°C (122°F).
- When washing do not direct any water towards electrical connectors, control units, the exhaust or any fill tank openings.
- Do not spray or wash components (for example, the engine) with cold water when hot.

GS25068,0000A9B-19-11NOV19

Controls and Instruments Maintenance

General Controls and Instruments Maintenance

- Ensure that controls and instruments are clean and no bindings are present. See your John Deere dealer for recommended cleaners to prolong life of products.
- Adjust mechanical SCV levers, shiftable PTO lever, and creeper lever. See your John Deere dealer for proper adjustments.

DP51502,0002AB9-19-06APR17

Engine Maintenance

Break-In Maintenance

After a minimum of 100 hours and a maximum of 500 hours of operation:

Replace Break-In Plus Engine Oil

IMPORTANT: If make-up oil is required during the break-in period, John Deere Break-In Plus oil must be used whenever possible. New engines are filled at the factory with Break-In Plus engine oil.

Do not add make-up oil until the oil level is **BELOW** the ADD mark on dipstick. (See Fuel, Lubricant, and Coolants section.)

If any of the following occur during the first 100 hours, it is advised to extend the break-in to 500 hours before changing the oil.

- Too much operating time at idle.
- Too much operating time at a constant speed.
- Too much light load usage.
- Make-up oil is required in the first 100 hours.

GS25068,00015AA-19-15APR21

Break-In Checks

IMPORTANT: Initial break-in maintenance interval of a new or rebuilt wet sleeve engine must last at least 100 hours with John Deere Break-In Plus oil. The surface mating of rings and liners usually occurs during the first 100 hours.

Maximum maintenance interval is the same as the maintenance interval recommended for your engine. (See Engine Oil and Filter Service Intervals in Fuels, Lubricants, and Coolants section.)

IMPORTANT: If engine oil must be added before first normal oil change, use John Deere Break-In Plus engine oil.

The engine is ready for normal operation. During first 100 hours of operation:

- Operate engine at heavy loads without reaching sustained maximum load.
- Avoid idling engine longer than 5 minutes. If engine idles longer than 5 minutes, stop engine.
- Closely observe coolant temperature during operation.
- Check air intake hoses and clamps. (See Air, Fuel, Coolant, and Exhaust Maintenance section.)
- Check for fluid leaks.
- Tighten wheel, wheel weight, and axle bolts after 3

HOURS, after **10 HOURS**, and **DAILY** for the first week of operation. (See Wheels and Tires Maintenance section.)

Daily or Every 10 Hours

Perform normal daily services:

- Check engine oil. (See Engine Maintenance section.)
- Clean dust unloading valve. (See Air, Fuel, Coolant, and Exhaust Maintenance section.)

For first 100 hours of machine operation, perform these additional services daily or every 10 hours:

- Drain water separator. (See Air, Fuel, Coolant, and Exhaust Maintenance section.)
- Check coolant level. (See Air, Fuel, Coolant, and Exhaust Maintenance section.)
- Lubricate rear and front hitch components. (See Hitch and Drawbar Maintenance section.)
- Inspect tires for cuts or punctures. (See Wheels and Tires Maintenance section.)

GS25068,00015AC-19-14APR21

Check Engine Oil Level

MAINTENANCE INTERVAL

Daily or Every 10 Hours

IMPORTANT: Engine comes from the factory, filled with John Deere Break-In Plus oil. (See Break-In Maintenance in this section.)

IMPORTANT:

- Do not operate engine with the oil level below the lower mark on dipstick.
- Avoid damage by maintaining full oil level.
- Use seasonal viscosity grade oil. (See Fuels, Lubricants, and Coolants section.)

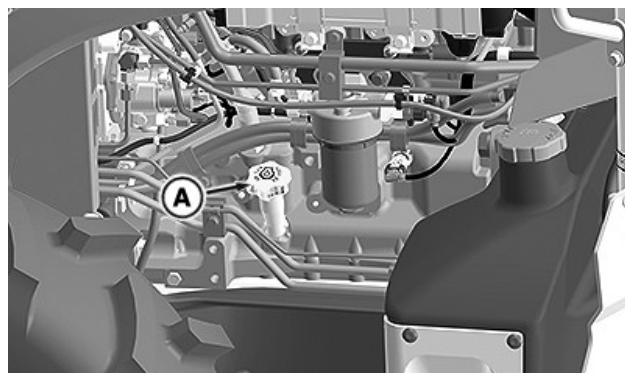

RXA0154377—UN—22FEB17

Left Side of Engine

A—Engine Oil Fill Cap/Dipstick

1. Park machine on level ground and shut off engine.
2. Remove key.
3. Allow engine to cool.
4. Remove engine oil fill cap/dipstick (A). Wipe off, then fully reinsert the dipstick.
5. Remove engine oil fill cap/dipstick (A). Check engine oil level. Oil level must be between two marks on dipstick.
6. If level is low, add oil through engine oil fill hole until even with the top mark on dipstick. Do not overfill.
7. Reinstall engine oil fill cap/dipstick (A) before operating engine.

GS25068,00015AB-19-14APR21

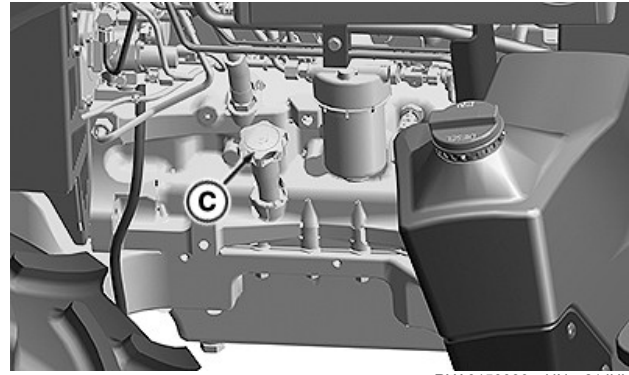

RXA0153039—UN—21JUL16

Left Side of Engine

- A—Engine Oil Drain Plug**
- B—Engine Oil Filter**
- C—Engine Oil Fill Cap/Dipstick**

1. Operate engine to warm oil.
2. Park machine on level ground and shut off engine.
3. Remove key.
4. Remove engine oil fill cap/dipstick (C).

NOTE: Place a container under drain plug (A) and capture waste oil. Dispose of oil properly.

5. Remove engine oil drain plug (A) and allow oil to drain.
6. Open hood.
7. Remove engine oil filter (B).

NOTE: Make sure that old filter gasket is removed from housing before installing new filter.

8. Apply a film of oil on the new oil filter gasket and install new filter. Hand-tighten plus 1/2 turn.
9. Install engine oil drain plug (A).
10. Add engine oil to engine oil fill hole. (See Fuel, Lubricants, And Coolants section for oil grades and specifications.)

Specification

4.5 Liter 4-Cylinder Engine
 Oil—Capacity. 13 L
 (3.4 gal)

11. Install engine oil fill cap/dipstick (C).
12. Remove engine oil fill cap/dipstick (C). Wipe off, then fully reinsert the fill cap/dipstick.
13. Remove engine oil fill cap/dipstick (C). Check engine oil level. Oil level must be between two marks on dipstick.
14. Reinstall fill cap/dipstick (C).
15. Start engine and inspect drain plug and filter for leaks.

Change Engine Oil and Filter

MAINTENANCE INTERVAL

INITIAL — 100 to 500 Hours

REGULAR (AFTER INITIAL CHANGE) — Every 500 HOURS If John Deere Plus-50 II oil and John Deere filter are used. Maintenance interval is every 250 hours for all other brands of oil or filters.

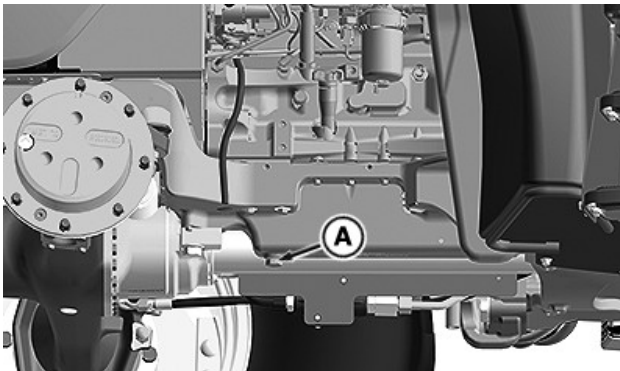

RXA0152210—UN—27OCT16

Bottom Left Side of Engine

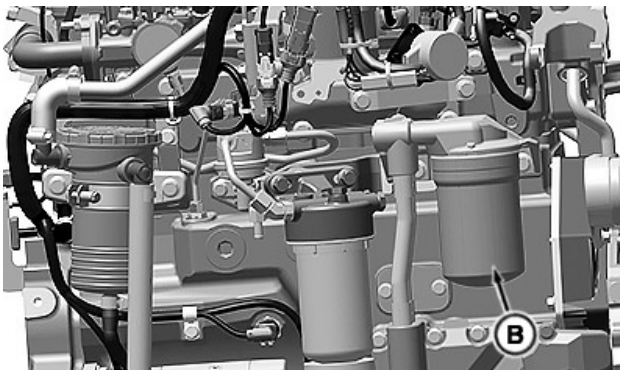

RXA0155753—UN—23NOV16

Right Side of Engine

16. Stop engine and remove key.
17. Recheck engine oil level on dipstick, add if necessary.
18. Lower hood.

GS25068,00015AE-19-23,JUL21

Clean Open Crankcase Vent

MAINTENANCE INTERVAL
Every 500 Hours

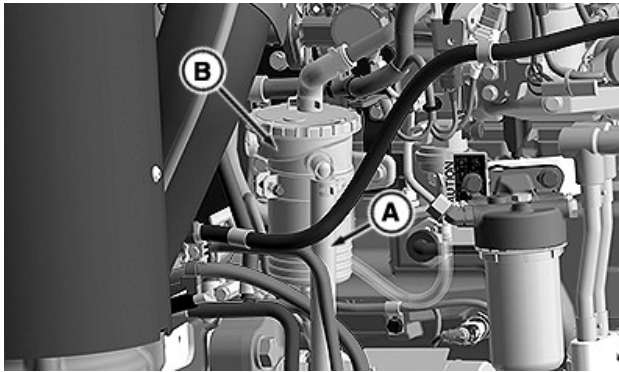

RXA0182224—UN—15APR21

A—Open Crankcase Vent Tube
B—Open Crankcase Vent Filter Housing

⚠ CAUTION: Reduce compressed air pressure to less than 210 kPa (2 bar) (30 psi) when using for cleaning purposes. Clear area of bystanders, guard against flying chips, and wear personal protection equipment, including eye protection.

1. Remove open crankcase vent tube (A) from the open crankcase vent filter housing (B).
2. Wash the open crankcase vent tube (A) in solvent or blow clean with compressed air.
3. Install open crankcase vent tube (A) to the open crankcase vent filter housing (B). Be sure that the vent tube is not kinked or pinched.

GS25068,00015AF-19-15APR21

Change Open Crankcase Ventilation Filter

MAINTENANCE INTERVAL
Every 1500 Hours

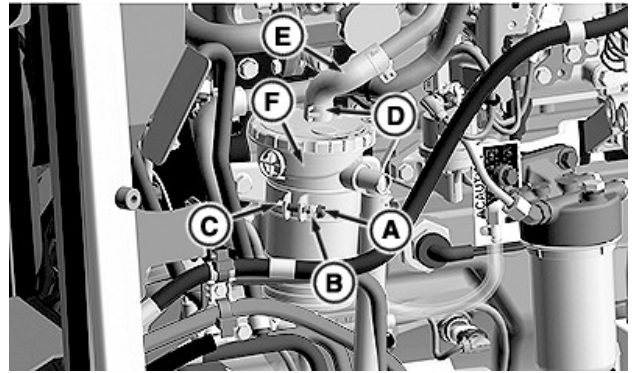

RXA0182225—UN—15APR21

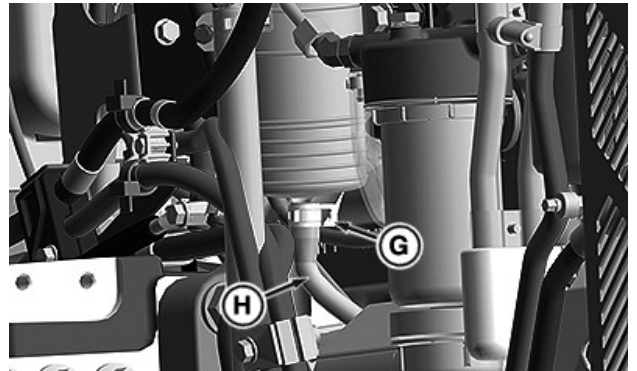

RXA0182226—UN—15APR21

A—Cap Screw
B—Spring
C—Lock Nut
D—Hose Clamp
E—Hose
F—Open Crankcase Vent Filter Housing
G—Hose Clamp
H—Hose

1. Remove and retain cap screw (A), spring (B), and lock nut (C).
2. Loosen hose clamp (C) and remove hose (D) on top of the open crankcase vent filter housing.
3. Loosen hose clamp (G) and remove hose (H) on bottom of the open crankcase vent filter housing.
4. Unscrew open crankcase vent filter housing top and remove filter.
5. Inspect open crankcase vent filter housing. Clean if necessary.
6. Install new filter and reinstall filter housing top.
7. Reinstall open crankcase vent filter housing.

GS25068,00015B0-19-15APR21

Check Fan Belt Tensioner

MAINTENANCE INTERVAL
Every 1000 Hours or Annually

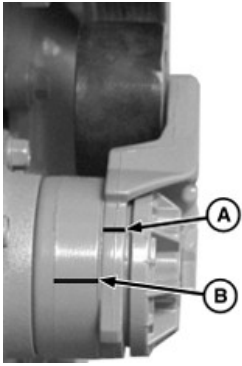

LV12526—UN—13APR05

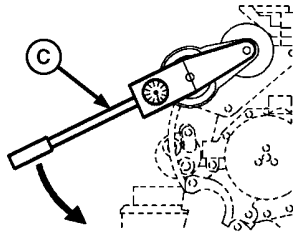

LV12528—UN—12APR05

- A—Mark on Swing Arm
- B—Mark on Tensioner Mounting Base
- C—Torque Wrench

NOTE: A belt tension gauge does not provide an accurate measurement of the belt tension. Measure tensioner spring tension using a torque wrench.

1. Place machine in park and shut off engine. Remove key.
2. Remove fan belt. See procedure in this section.
3. Put a mark (A) on the swing arm of the tensioner as shown.
4. Measure 21 mm (0.83 in) from (A) and put a mark (B) on tensioner mounting base.
5. Rotate the swing arm using a torque wrench until marks (A and B) are aligned.

Pull tensioner with torque wrench away from engine.

6. Record torque wrench measurement and compare with specification. If recorded measurement is below specification, have your John Deere dealer replace tensioner assembly.

Specification

Belt Tensioner—Torque. 18—22 N·m
(159—195 lb·in)

7. Install fan belt. See procedure in this section.

GS25068,00015B1-19-15APR21

Change Fan Belt

MAINTENANCE INTERVAL
Every 1000 Hours or Annually

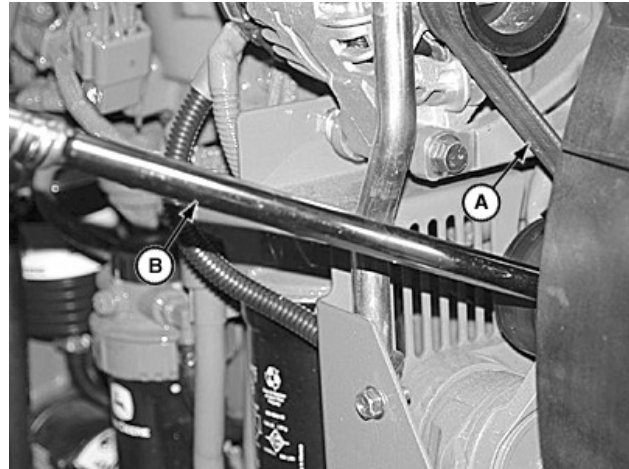

LV14667—UN—18AUG11

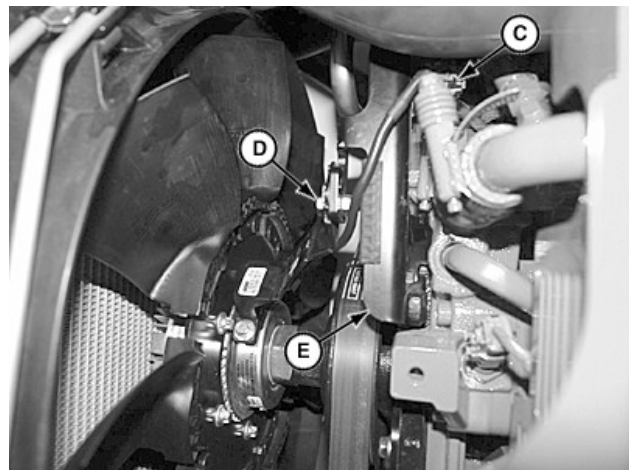

LV14668—UN—18AUG11

- A—Belt
- B—Breaker Bar
- C—Fan Clutch Connector
- D—Lock Nut and Flanged Screw
- E—Wire Harness Support Bracket

NOTE: Fan belt drive has an automatic tensioner that does not require adjustment.

1. Place machine in park and shut off engine. Remove key.
2. Release tension on belt using a long-handle 1/2-in drive breaker bar (B) to pull the tensioner away from engine.
3. Remove belt (A) from alternator pulley.
4. Release tension on tensioner and remove breaker bar.
5. Disconnect fan clutch connector (C).
6. Remove lock nut and flanged screw (D) from wire harness support bracket (E).
7. Use breaker bar to push the tensioner into position for removing the belt.
8. Remove belt by bringing it over the wire harness

support and cooling fan. Slip it between the fan blades and fan shroud.

- Install new belt in reverse order of removal.

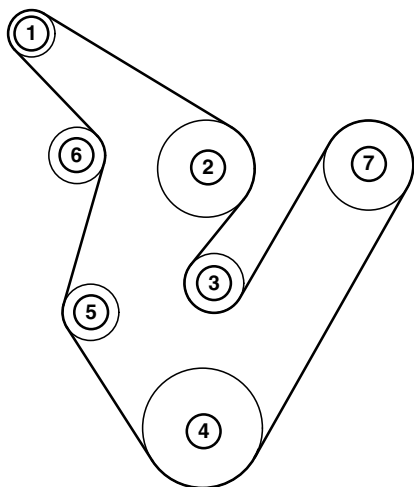

RXA0154358—UN—27OCT16

Fan Belt Routing

Belt Routing	
1	Alternator
2	Fan Drive
3	Idler
4	Crankshaft Pulley
5	Coolant Pump
6	Tensioner
7	Air Conditioning Compressor

- Install wire harness support using lock nut and flanged screw. Tighten to specification.

Specification

Wire Harness Support Lock
 Nut—Torque..... 14 N·m
 (124 lb·in)

- Reconnect fan clutch connector (C).
- Use breaker bar to push the tensioner into position for belt installation.

GS25068,00015F4-19-20APR21

Adjust Engine Valve Clearance

<p>MAINTENANCE INTERVAL Every 3000 Hours or 3 Years</p>

Have your John Deere dealer check and adjust engine valve clearance.

GS25068,00015B3-19-15APR21

Air, Fuel, Coolant, and Exhaust Maintenance

Required Emission-Related Information

Service Provider

A qualified repair shop or person of the owner's choosing may maintain, replace, or repair emission control devices and systems with original or equivalent replacement parts. However, warranty, recall, and all other services paid for by John Deere must be performed at an authorized John Deere service center.

DX,EMISSIONS,REQINFO-19-12JUN15

Recommended Dealer Performed Service

Check Coolant Properties

MAINTENANCE INTERVAL

Every 1000 Hours or Annually

Ask your John Deere dealer to check engine coolant properties. Use Cool-Gard II only if additional coolant is required.

Change Thermostat, Drain Coolant, and Replace Coolant

MAINTENANCE INTERVAL

Every 6000 Hours or 6 Years If Cool-Gard II is used. Machine must be initially filled and only serviced with properly diluted Cool-Gard II coolant.

Every 2000 Hours or 2 Years If Cool-Gard II is not used.

Have your John Deere dealer flush the cooling system, replace thermostat, and fill the system with Cool-Gard II.

Drain and Flush Fuel Tank

If excessive amounts of water or dirt are found in the fuel filter and water separator, ask your John Deere dealer to drain and flush fuel tank.

GS25068,00015B4-19-23JUL21

Check Engine and Exhaust Compartments for Debris

IMPORTANT: Directing pressurized water at electronic/electrical components, connectors, bearings and hydraulic seals, fuel injection pump or other sensitive components can cause product malfunctions. Reduce pressure and spray at a 45 to 90 degree angle.

Directing pressurized air at electronic/electrical components or connectors can cause buildup of static electricity and product malfunctions.

Never steam clean or pour cold water on an injection pump that is operating or hot. Pump could seize.

1. Shut off engine and allow to cool.

2. Open and raise engine hood.
3. Remove any crop or debris within engine and exhaust compartments, especially around turbocharger, exhaust manifold, and exhaust aftertreatment system.
4. Reinstall all shields. Close and securely latch hood.

DP51502,0002AC4-19-24MAR17

Clean Diesel Particulate Filter (DPF)

1. When exhaust filter and warning light indicators are illuminated, ensure that exhaust filter cleaning is set to "Auto".
2. Operate machine above 1200 rpm to allow an automatic exhaust filter cleaning to occur.
3. If indicators remain illuminated after an automatic cleaning has occurred, additional cleaning is required. Perform parked exhaust filter cleaning (if system allows). (See Air, Fuel, Coolant, and Exhaust Operation section for procedure.)
4. If a parked exhaust filter cleaning has been performed and exhaust filter and warning light indicators are still illuminated, contact your John Deere dealer.

GS25068,0005420-19-20SEP18

Change Diesel Exhaust Fluid (DEF) Dosing Unit Filter

MAINTENANCE INTERVAL

Every 4500 Hours or 5 Years

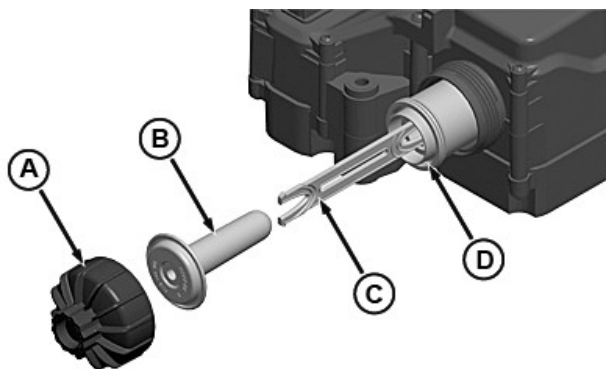

RG22534—UN—21MAR13

DEF Dosing Unit Filter

- A—DEF Dosing Unit Filter Cover
- B—DEF Dosing Unit Filter Equalizing Element
- C—DEF Dosing Unit Filter Tool (supplied with new filter)
- D—DEF Dosing Unit Filter

CAUTION: Avoid contact with eyes. In case of contact, immediately flush eyes with large amounts of water for a minimum of 15 minutes. Reference the Materials Safety Data Sheet (MSDS) for additional information.

IMPORTANT: If DEF is spilled or contacts any surface other than the storage tank, immediately clean the surface with clear water. DEF is corrosive to painted and unpainted metallic surfaces and can distort some plastic and rubber components.

Spilled DEF, if left to dry or if only wiped away with a cloth, leaves a white residue. Improperly cleaned DEF spill can interfere with diagnosis of Selective Catalytic Reduction (SCR) system leakage problems.

NOTE: See your John Deere equipment technical manual or OEM manufacturer's technical manual for DEF dosing unit filter location.

IMPORTANT: Avoid system and filter damage. Ensure that DEF system is not frozen before changing filter. If system is frozen, operate engine until system has thawed completely.

NOTE: Servicing DEF dosing unit filter may require removing additional covers or components.

1. Remove DEF dosing unit filter cover (A).
2. Remove and discard DEF dosing unit filter equalizing element (B).

NOTE: DEF dosing unit filter tool (C) is supplied with replacement filter.

3. Insert "Black" end of DEF dosing unit filter tool (C) into DEF dosing unit filter (D) until CLICK is felt or

heard indicating DEF dosing unit filter tool is fully engaged.

NOTE: A tool such as a screwdriver can be inserted into DEF dosing unit filter tool slot to assist removal.

4. Pull DEF dosing unit filter tool and DEF dosing unit filter from DEF dosing unit. Discard DEF dosing unit filter and DEF dosing unit filter tool.
5. Clean DEF dosing unit threads and mating surfaces with distilled water.
6. Lubricate DEF filter O-rings with clean DEF. Carefully insert DEF dosing unit filter into DEF dosing unit.
7. Install new DEF dosing unit filter equalizing element into DEF dosing unit filter.
8. Install DEF dosing unit filter cover and tighten to specification.

Specification

DEF Dosing Unit Filter	
Cover—Torque	23 N·m (204 lb·in)

GS25068,00015B5-19-15APR21

Change Diesel Exhaust Fluid (DEF) Tank Header Suction Screen

MAINTENANCE INTERVAL
Every 4500 Hours or 5 Years

DEF Tank Header Identification

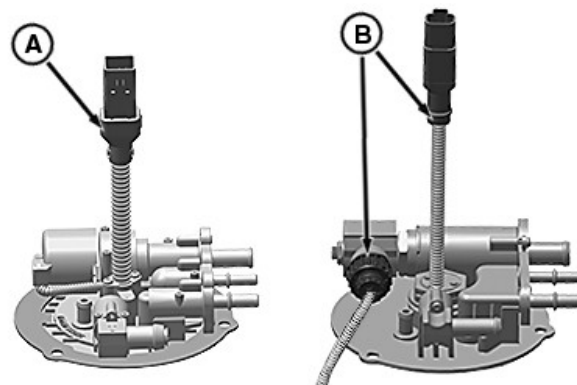

RG29623—UN—18JUL17

DEF Tank Header Identification

- A—Type A DEF Tank Header (one electrical connection)
- B—Type B DEF Tank Header (two electrical connections)

NOTE: Accessing DEF tank header may require removing additional covers or components.

Type A DEF tank header has one wiring harness connection (A). Type B DEF tank header has two wiring

harness connections (B). Refer to the procedure that is applicable to your DEF tank header.

Replace Type A DEF Tank Header Suction Screen

CAUTION: Avoid contact with eyes. In case of contact, immediately flush eyes with large amounts of water for a minimum of 15 minutes. Reference the Materials Safety Data Sheet (MSDS) for additional information.

IMPORTANT: If DEF is spilled or contacts any surface other than the storage tank, immediately clean the surface with clear water. DEF is corrosive to painted and unpainted metallic surfaces and can distort some plastic and rubber components.

Spilled DEF, if left to dry or if only wiped away with a cloth, leaves a white residue. Improperly cleaned DEF spill can interfere with diagnosis of Selective Catalytic Reduction (SCR) system leakage problems.

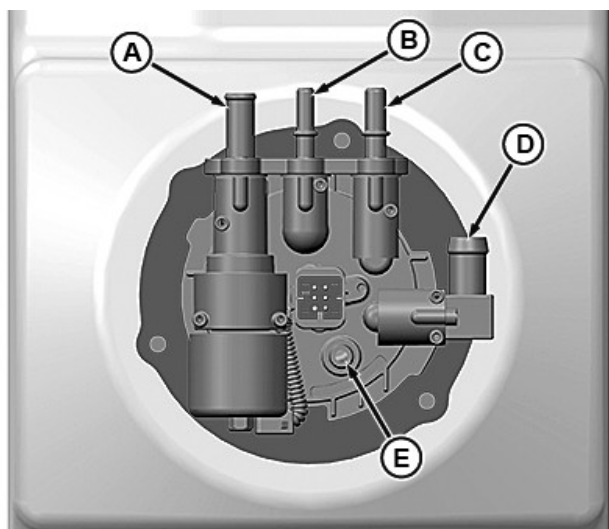

DEF Tank Header Fittings

A—Coolant Outlet Fitting
 B—DEF Return Line Fitting
 C—DEF Supply Line Fitting
 D—Coolant Inlet Fitting
 E—Vent Line Fitting

1. Clear all debris from area around DEF tank header.

CAUTION: Explosive release of fluids from pressurized cooling system can cause serious burns. Before disconnecting coolant hoses, wait until engine coolant is cool enough to touch the surge tank cap with bare hands. Slowly loosen the surge tank cap to first stop to relieve pressure.

IMPORTANT: Cap and plug all lines and fittings to prevent contamination. Coolant in DEF causes Selective Catalytic Reduction (SCR) system performance issues.

2. Disconnect coolant hoses from fittings (A and D).
3. Disconnect DEF return and supply lines from fittings (B and C).
4. Disconnect DEF tank header electrical connector.
5. Remove vent hose from fitting (E).

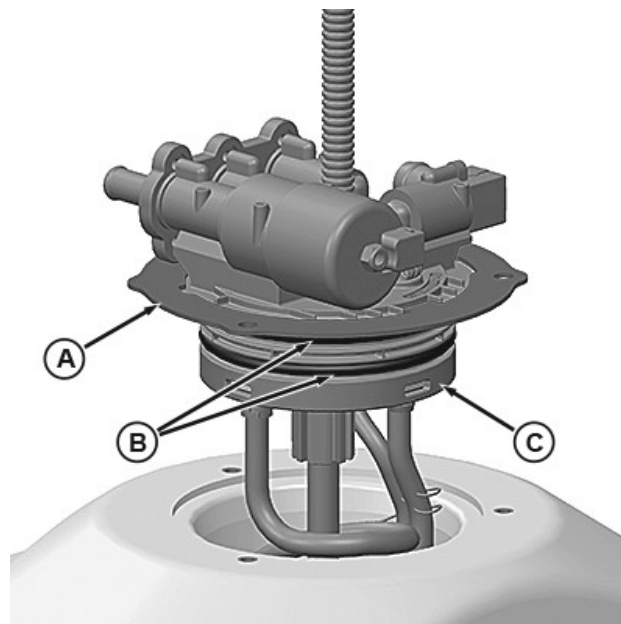

RG29625—UN—25JUL17

DEF Tank Header

A—DEF Tank Header Locking Ring
 B—O-Ring (2)
 C—DEF Tank Header

6. Remove cap screws from DEF tank header locking ring (A).
7. Remove DEF tank header (C) from tank.
8. Remove O-rings (B) and inspect for damage.
9. Replace O-rings (B) if necessary.

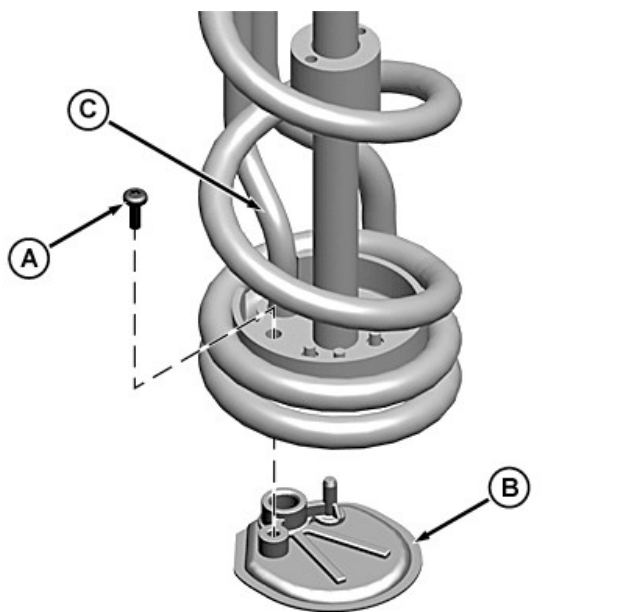

DEF Suction Screen

RG23672—UN—01JUL13

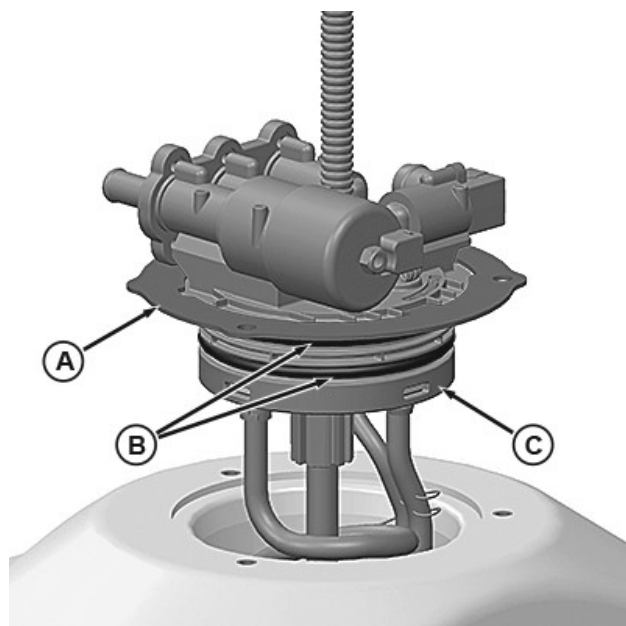

DEF Tank Header

RG29625—UN—25JUL17

- A—Screw
- B—Suction Screen
- C—Suction Tube

10. Remove screw (A) that secures suction screen (B) to suction tube (C).
11. Remove suction screen (B).
12. Install suction screen (B) to suction tube (C).
13. Install screw (A) and tighten to specification.

Specification

DEF Suction Screen	
Screw—Torque	1 N·m (11 lb·in)

- A—DEF Tank Header Locking Ring
- B—O-Ring (2)
- C—DEF Tank Header

14. Lubricate O-rings (B) with clean DEF.
15. Insert DEF header into tank and align holes on locking ring (A) with holes in tank.

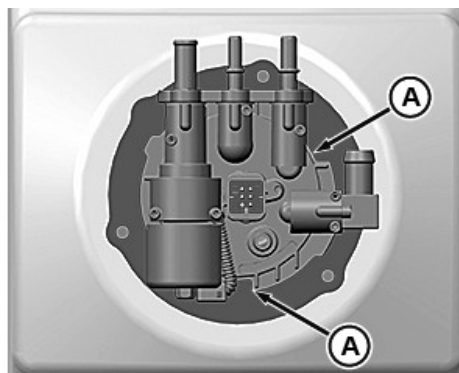

Alignment Notches

RG25370—UN—03APR14

- A—Alignment Notch (2)

IMPORTANT: Prevent DEF leak, header, and lock ring damage. Ensure that alignment notches on the locking ring are properly aligned with plastic tabs on the header.

16. Install stainless steel cap screws into mounting holes and tighten to specification.

Specification

DEF Tank Header M6 Cap	
Screw—Torque	9 N·m (80 lb·in)

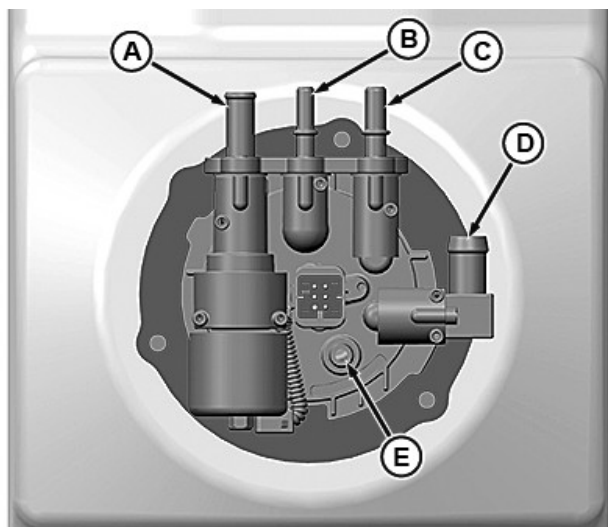

RG29624—UN—19JUL17

DEF Tank Header Fittings

- A—Coolant Outlet Fitting
- B—DEF Return Line Fitting
- C—DEF Supply Line Fitting
- D—Coolant Inlet Fitting
- E—Vent Line Fitting

17. Connect 9.5-mm (3/8-in) vent hose to fitting (E).
18. Connect 16-mm (5/8-in) coolant hose to coolant inlet fitting (D).
19. Connect 13-mm (1/2-in) coolant hose to coolant outlet fitting (A).

IMPORTANT: Push DEF line onto fitting until you hear a “click”, then lightly pull back to ensure that it is connected and locked in place.

NOTE: DEF supply and return lines have unique sized fittings.

20. Connect DEF return and supply lines to fittings (B and C).
21. Connect DEF tank header electrical connector.

Replace Type B DEF Tank Header Suction Screen

CAUTION: Avoid contact with eyes. In case of contact, immediately flush eyes with large amounts of water for a minimum of 15 minutes. Reference the Materials Safety Data Sheet (MSDS) for additional information.

IMPORTANT: If DEF is spilled or contacts any surface other than the storage tank, immediately clean the surface with clear water. DEF is corrosive to painted and unpainted metallic surfaces and can distort some plastic and rubber components.

Spilled DEF, if left to dry or if only wiped away with a cloth, leaves a white residue. Improperly cleaned DEF spill can interfere with diagnosis of Selective Catalytic Reduction (SCR) system leakage problems.

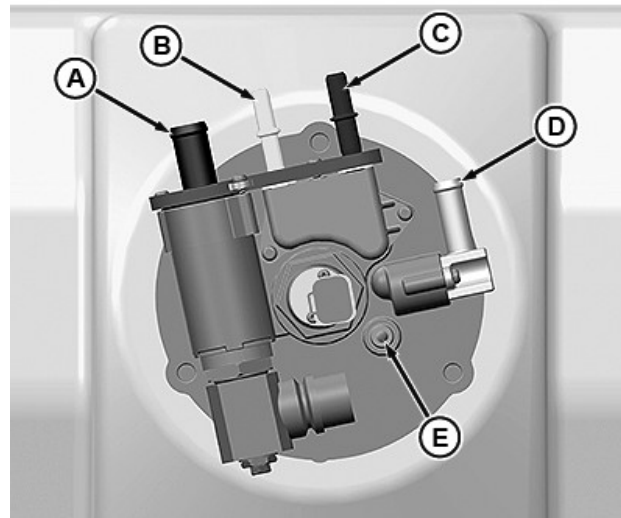

RG29626—UN—19JUL17

DEF Tank Header Fittings

- A—Coolant Inlet Fitting
- B—DEF Return Line Fitting
- C—DEF Supply Line Fitting
- D—Coolant Outlet Fitting
- E—Vent Line Fitting

1. Clear all debris from area around DEF tank header.

CAUTION: Explosive release of fluids from pressurized cooling system can cause serious burns. Before disconnecting coolant hoses, wait until engine coolant is cool enough to touch the surge tank cap with bare hands. Slowly loosen surge tank cap to first stop to relieve pressure.

IMPORTANT: Cap and plug all lines and fittings to prevent contamination. Coolant in DEF causes Selective Catalytic Reduction (SCR) system performance issues.

2. Disconnect coolant hoses from fittings (A and D).
3. Disconnect DEF return and supply lines from fittings (B and C).
4. Disconnect DEF tank header electrical connectors.
5. Remove vent hose from fitting (E).

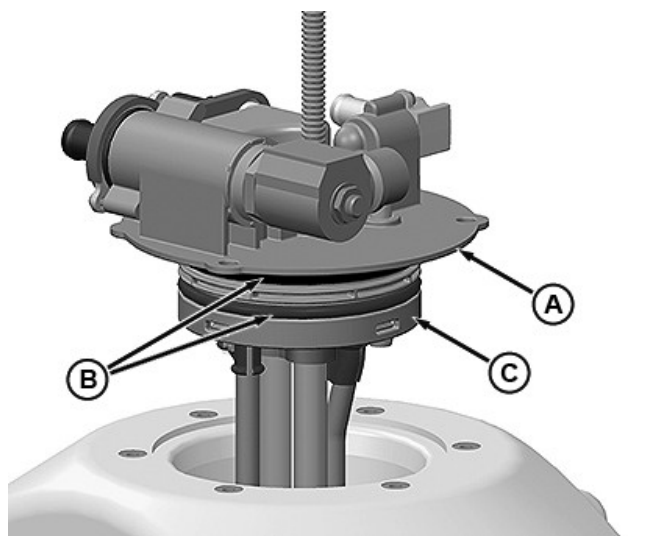

DEF Tank Header

RG29627—UN—19JUL17

- A—DEF Tank Header Mounting Flange
- B—O-Ring (2)
- C—DEF Tank Header

6. Remove cap screws from DEF tank header mounting flange (A).
7. Remove DEF tank header (C) from tank.
8. Remove O-rings (B) and inspect for damage.
9. Replace O-rings (B) if necessary.

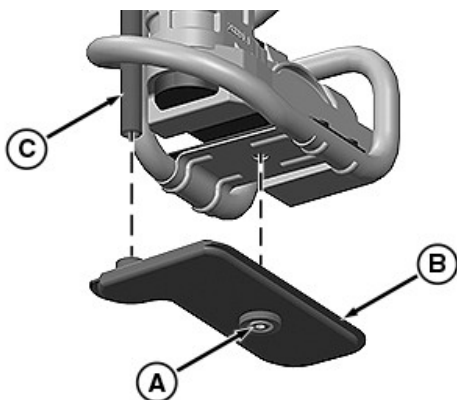

DEF Suction Screen

RG28054—UN—29MAR16

- A—Screw
- B—Suction Screen
- C—Suction Tube

10. Remove screw (A) that secures suction screen (B) to suction tube (C).
11. Remove suction screen (B).
12. Install suction screen (B) to suction tube (C).
13. Install screw (A) and tighten to specification.

Specification

DEF Suction Screen	
Screw—Torque.	1 N·m (11 lb·in)

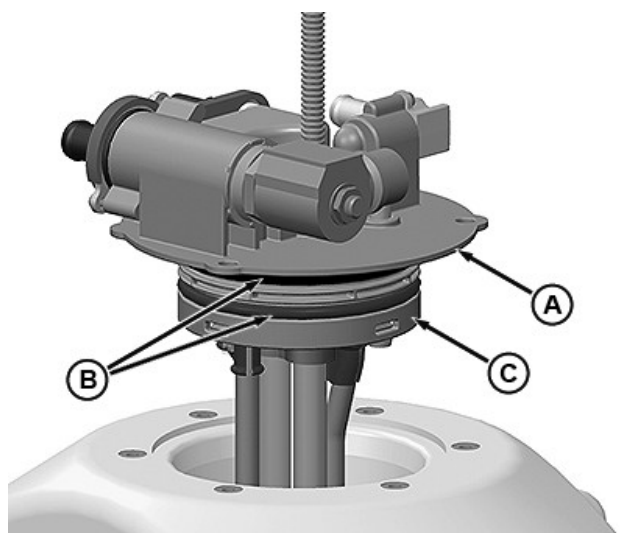

DEF Tank Header

RG29627—UN—19JUL17

- A—DEF Tank Header Mounting Flange
- B—O-Ring (2)
- C—DEF Tank Header

14. Lubricate O-rings (B) with clean DEF.
15. Insert DEF header (C) into tank and align mounting holes on mounting flange (A) with holes in tank.
16. Install stainless steel M6 cap screws into mounting holes and tighten to specification.

Specification

DEF Tank Header Cap	
Screw—Torque.	9 N·m (80 lb·in)

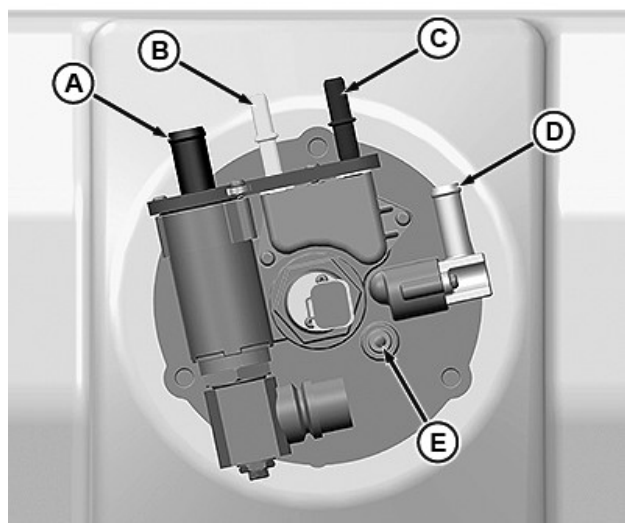

DEF Tank Header Fittings

RG29626—UN—19JUL17

- A—Coolant Inlet Fitting
- B—DEF Return Line Fitting
- C—DEF Supply Line Fitting
- D—Coolant Outlet Fitting
- E—Vent Line Fitting

17. Connect 9.5-mm (3/8-in) vent hose to fitting (E).
18. Connect 16-mm (5/8-in) coolant hose to coolant inlet fitting (A).
19. Connect 13-mm (1/2-in) coolant hose to coolant outlet fitting (D).

IMPORTANT: Push DEF line onto fitting until you hear a “click”, then lightly pull back to ensure that it is connected and locked in place.

NOTE: DEF supply and return lines have unique sized fittings.

20. Connect DEF return and supply lines to fittings (B and C).
21. Connect DEF tank header electrical connectors.

GS25068,00015B6-19-15APR21

Clean Diesel Exhaust Fluid (DEF) Tank

CAUTION: Avoid contact with eyes. In case of contact, immediately flush eyes with large amounts of water for a minimum of 15 minutes. Reference the Materials Safety Data Sheet (MSDS) for additional information.

IMPORTANT: If DEF is spilled or contacts any surface other than the storage tank, immediately clean the surface with clear water. DEF is corrosive to painted and unpainted metallic surfaces and can distort some plastic and rubber components.

Spilled DEF, if left to dry or if only wiped away with a cloth, leaves a white residue. Improperly cleaned DEF spill can interfere with diagnosis of Selective Catalytic Reduction (SCR) system leakage problems.

If foreign material or fluid has been added to the DEF tank, drain the DEF tank, flush, and fill with new DEF.

If DEF quality is in question, pull a sample out of the DEF tank and place into a clear container. DEF should be crystal clear with a light ammonia smell. If DEF appears cloudy, has a colored tint, or has a profound ammonia smell, it is likely not within specification. DEF in this condition should not be used.

1. Remove drain plug (if equipped), and drain or siphon bad DEF from DEF tank.

NOTE: Cleaning can take place with DEF tank installed or removed.

2. Clean DEF tank with new DEF.

DEF must pass visual, smell, and concentration checks before running the engine. See Diesel Exhaust Fluid (DEF) – For Use In Selective Catalytic Reduction (SCR) Equipped Engines in the Fuels, Lubricants, and Coolants Section for more information.

3. Drain or siphon DEF tank.

NOTE: Repeat steps 2—3 until DEF tank has been cleaned.

4. **Early version:** Change DEF dosing unit filter and DEF tank header suction screen.

Later version: Change DEF dosing unit filter and DEF inline filter.

5. If removed, install DEF tank drain plug.
6. If removed, install DEF tank.
7. Fill DEF tank with new DEF.
8. Check DEF concentration with DEF refractometer, such as JDG11594 or JDG11684. The correct DEF concentration is 31.8% — 33.2%. See your authorized dealer for more information.
9. If DEF is not within specification, does not appear clear, or does not have a slight ammonia smell, contact your authorized dealer.

GS25068,0000D0D-19-07FEB20

Drain Diesel Exhaust Fluid (DEF) Tank

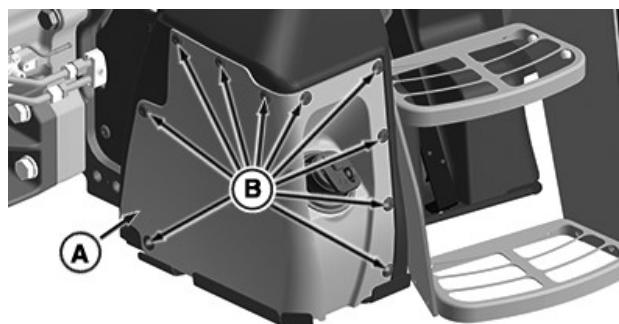

RXA0154380—UN—22FEB17

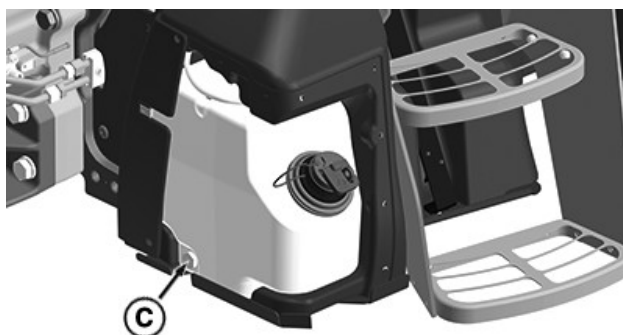

RXA0154381—UN—22FEB17

- A—DEF Tank Cover
- B—Screws (10)
- C—DEF Tank Drain Plug
- D—Fuel Tank Outer Shield

IMPORTANT: Do not overtorque the drain plug.

1. Remove screws (B) and DEF tank cover (A). Remove DEF tank cap if necessary to remove cover.
2. Place a container below the drain and capture waste. Dispose of waste properly.
3. Remove DEF tank drain plug (C) and drain DEF from tank.
4. Check o-ring for defects. Replace if needed.
5. Clean DEF tank. (See Cleaning Diesel Exhaust Fluid (DEF) Tank in this section.)
6. Clean out any DEF crystallization in threads.
7. Install drain plug and tighten to specification.

Specification

DEF Tank Drain Plug—Torque. 25 N·m
(18 lb·ft)

8. Clean all DEF from machine surfaces with clean water.

GS25068,00015B7-19-15APR21

Service Air Cleaner Elements

<p>MAINTENANCE INTERVAL Every 1000 Hours or Annually</p>



RXA0152424—UN—28OCT16

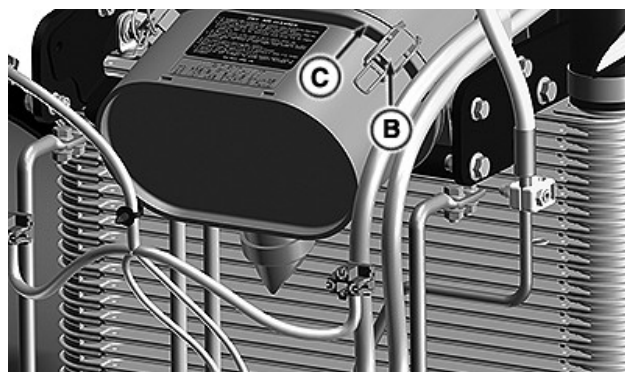

RXA0153091—UN—28JUL16

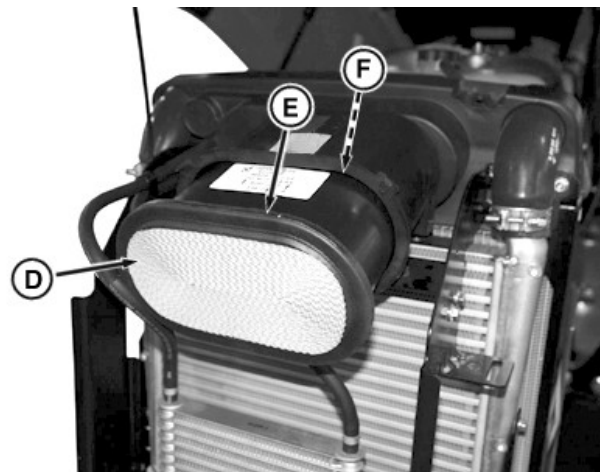

RXA0156171—UN—14DEC16

- A—Air Filter Restriction Indicator
- B—Latch
- C—Cover
- D—Primary Air Cleaner Element
- E—Guide Ring
- F—Secondary Air Cleaner Element

IMPORTANT: Dirty air cleaner element is indicated when air filter restriction indicator (A) appears on the information display.

1. Release latch and raise hood.
2. Open the latch (B) and cover (C).
3. Remove primary air cleaner element (D). If primary element does not pull out with ease, move side-to-side.

4. When the air cleaner element must be serviced in the field, tap it on the palm of your hand. Do not use compressed air or filter damage occurs.
5. Inspect guide ring (E) for damage.
6. Replace elements if core material or seals (both ends) are damaged, or if indicator remains illuminated.
7. Install elements and reinstall the air filter cover.
8. Close the hood.

GS25068,00015B8-19-15APR21

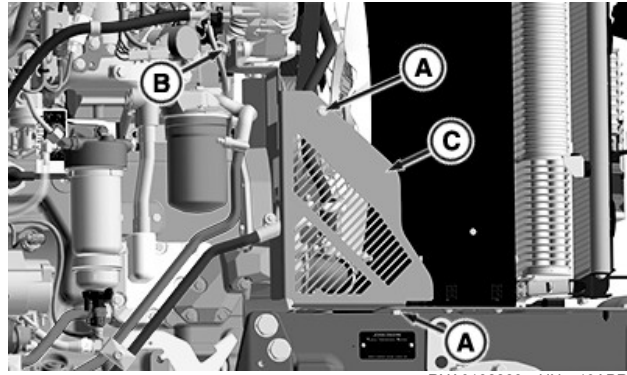

RXA0182228—UN—19APR21

Right Side of Engine

- A—Cap Screw (2)
 B—Lock Nut
 C—Fan Shield

4. Remove and retain cap screws (A), lock nut (B), and fan shield (C).

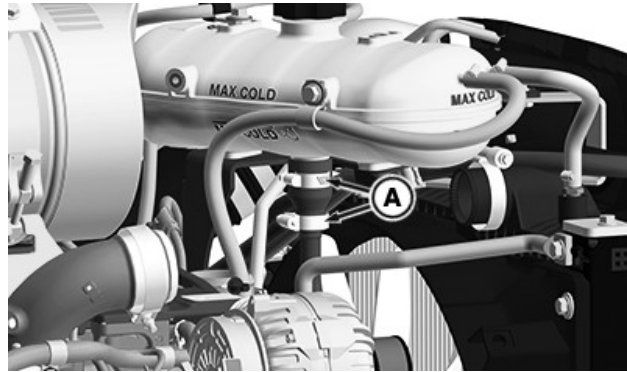

RXA0182229—UN—19APR21

- A—Hose Clamp (2)

5. Inspect hose clamps (A) on the bottom of the coolant tank. Tighten any loose hose clamps.

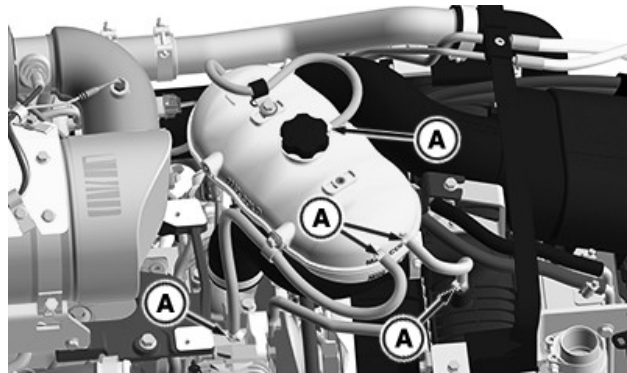

RXA0182230—UN—19APR21

- A—Hose Clamp (5)

6. Inspect hose clamps (A). Tighten any loose hose clamps.

Check and Tighten Air Intake System and Coolant System Hose Clamps

MAINTENANCE INTERVAL
 First 100 Hours

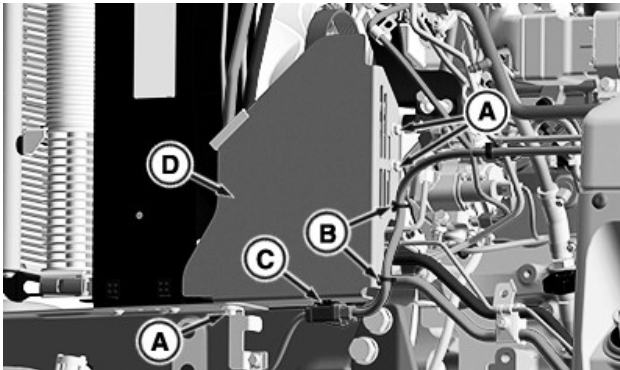

RXA0182227—UN—19APR21

Left Side of Engine

- A—Cap Screw (3)
 B—Wire Clip (2)
 C—Connector Clip
 D—Fan Shield

⚠ CAUTION: Do not operate the engine without the fan shields installed.

1. Park machine, shut off engine, and remove key.
2. Raise the hood.
3. Remove and retain cap screws (A), wire clips (B), connector clip (C), and fan shield (D).



RXA0182231—UN—19APR21

Right Side of Engine

A—Hose Clamp (4)

7. Inspect hose clamps (A). Tighten any loose hose clamps.

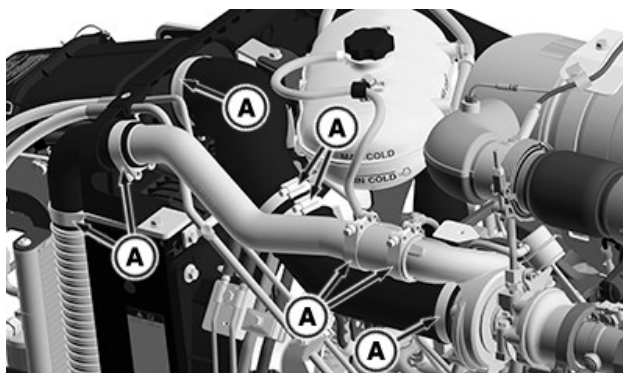

RXA0182232—UN—19APR21

Left Side of Engine

A—Hose Clamp (8)

8. Inspect hose clamps (A). Tighten any loose hose clamps.
9. Reinstall shields and lower hood before operating machine.

GS25068,00015BA-19-20APR21

Clean Air Filter Dust Unloading Valve

MAINTENANCE INTERVAL

Daily or Every 10 Hours

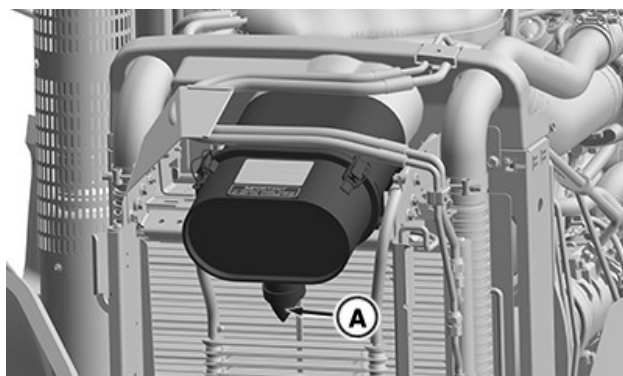

RXA0154394—UN—24FEB17

A—Dust Unloading Valve

IMPORTANT: Do not operate the engine without air cleaner elements or dust unloading valve installed.

1. Park machine on level ground and shut off engine.
2. Raise hood.
3. Squeeze the end of the dust unloading valve (A) open and remove any excessive buildup of dust and dirt. Replace if damaged.
4. Lower hood.

GS25068,00015BB-19-16APR21

Clean Grille Screens and Cooling Package



RXA0153092—UN—28JUL16

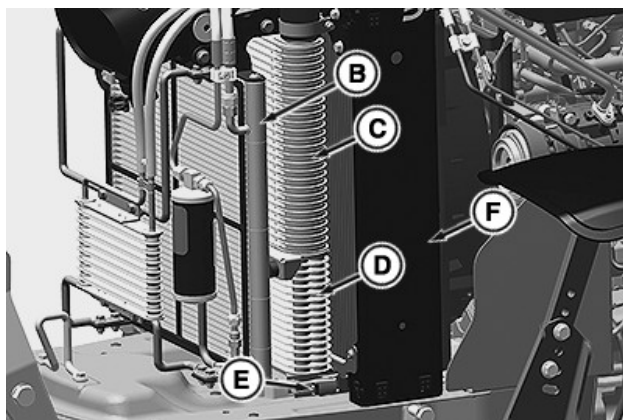

RXA0153101—UN—06DEC16

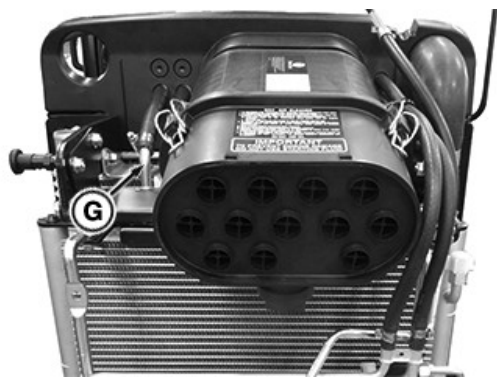

RXA0153100—UN—01AUG16

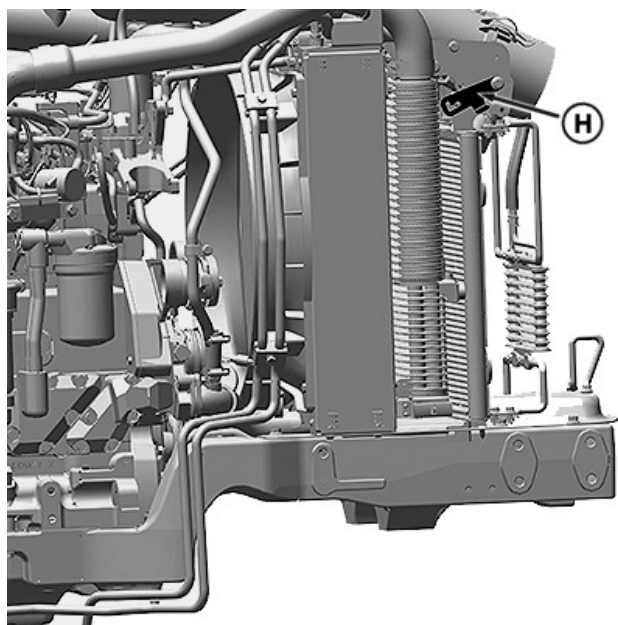

RXA0155654—UN—15NOV16

- A—Grille
- B—Air Conditioner Condenser
- C—Charge Air Cooler
- D—Hydraulic Oil Cooler
- E—Clip
- F—Radiator
- G—Hydraulic Oil Cooler Lines
- H—Release Latch

⚠ CAUTION: Reduce compressed air pressure to less than 210 kPa (2 bar) (30 psi) when using for cleaning purposes. Clear area of bystanders, guard against flying chips, and wear personal protection equipment including eye protection.

1. Remove trash buildup on the front grille (A) as required.
2. Release hood latch and raise hood.
3. Inspect air conditioner condenser (B), charge air cooler (C), hydraulic oil cooler (D), and radiator (F) for debris. Clean using compressed air.

If a more thorough cleaning is required, air conditioner condenser and hydraulic oil cooler can be tipped out of position for easier access.

4. **Air Conditioner Condenser:** Release clip (E) and pull conditioner condenser up. Clean as needed.
5. **Hydraulic Oil Cooler:** While the condenser is raised up, inspect charge air cooler (C) and hydraulic oil cooler (D).
6. **Radiator:** Release clip (E) on the hydraulic oil cooler (D) and raise up to inspect radiator.
7. Inspect hydraulic oil cooler lines (G) for loose connections or any damage.
8. Straighten any bent fins.
9. Lift release latch (H).
10. Return air conditioner condenser and hydraulic oil cooler to their original positions. Secure them with their clips (E).

NOTE: Verify that lines are not pinched or kinked when coolers are repositioned.

HV12280,0000949-19-29JAN21

Do Not Modify Fuel System

IMPORTANT: Increasing horsepower or altering fuel and air delivery beyond the factory rating causes emissions to exceed United States Environmental Protection Agency (EPA) approved levels. Violations of EPA regulations can result in substantial fines to persons or companies committing such violations.

Machine warranty is void if power level is changed from factory specifications.

Do not attempt to service injection pump or fuel injectors yourself. Special training and special tools are required. See your John Deere dealer.

DP51502,0002ACB-19-02FEB17

Drain Water and Sediment from Fuel Filter

<p>MAINTENANCE INTERVAL</p> <p>Daily or Every 10 Hours</p>

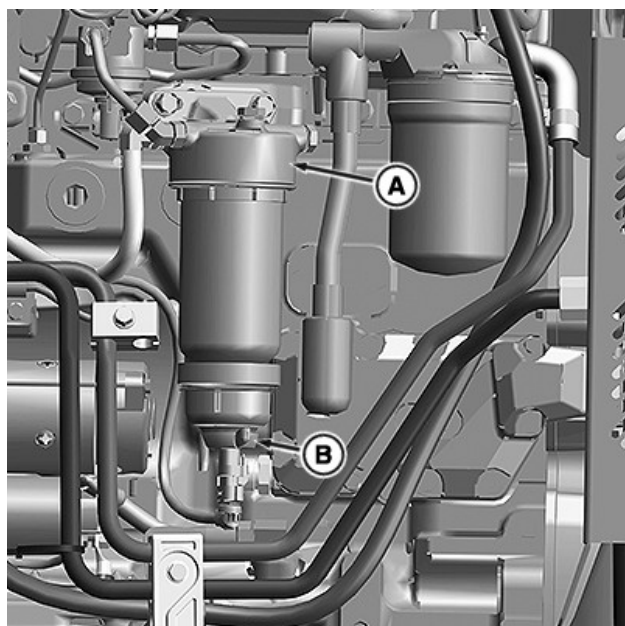

RXA0153093—UN—28JUL16

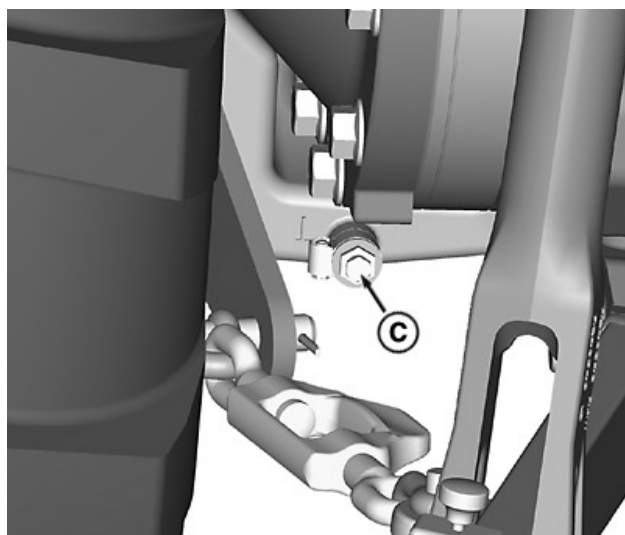

RXA0153094—UN—28JUL16

- A—Primary Fuel Filter
- B—Water Separator Drain Valve
- C—Fuel Tank Drain Plug

IMPORTANT: Place a suitable sized container under the fuel drain locations (filters, water separator, and tanks). Dispose of waste properly.

1. Park machine on level ground and shut off engine. Remove key.
2. Raise hood and locate primary fuel filter (A) on the right-hand side of machine.
3. Open water separator drain valve (B) to bleed accumulated water and sediment from filter. Close when clear fuel runs from the drain valve.
4. Run engine for minimum of 20 seconds and check water separator drain valve again for water and sediment.

5. If moisture or sediment is present, drain fuel tank.
6. Open fuel tank drain plug (C) to bleed accumulated moisture and sediment from the fuel tank.
7. Apply Teflon tape or equivalent to threads of the drain plug.
8. Tighten plug when clear fuel runs from the fuel tank drain. Replace and tighten.
9. Lower hood.

GS25068,00015BC-19-26JUL21

Bleed Fuel System

⚠ CAUTION: Escaping fluid under pressure has the potential to penetrate the skin, causing serious injury. Avoid the hazard by relieving pressure before disconnecting hydraulic or other lines. Tighten all connections before applying pressure. Search for leaks with a piece of cardboard. Protect hands and body from high-pressure fluids.

If an accident occurs, see a doctor immediately. Any fluid injected into the skin must be surgically removed within a few hours or gangrene can result. Doctors unfamiliar with this type of injury must reference a knowledgeable medical source. Such information is available from Deere & Company Medical Department in Moline, Illinois, U.S.A.

IMPORTANT: To avoid injection pump damage, Do not attempt to start the engine while bleeding the fuel system.

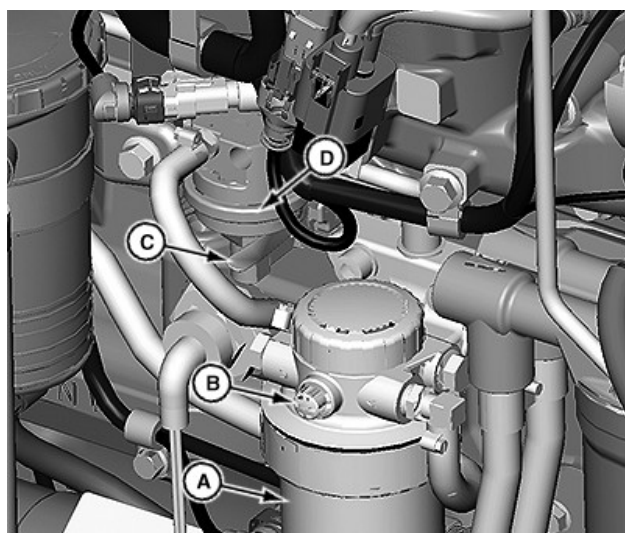

LV23097—UN—17SEP14

Right Side of Engine

- A—Fuel Filter
- B—Bleed Screw
- C—Priming Mechanism

D—Transfer Pump

1. Park machine on level ground. Remove key.
2. Check fuel level. Add if necessary.
3. Raise hood and locate primary fuel filter (A) on the right-hand side of machine.
4. Loosen filter housing bleed screw (B). Capture the discharge waste and dispose of properly.
5. Push priming mechanism (C) at the transfer pump (D) until all air is purged and fuel runs out smoothly from bleed screw. Tighten bleed screw.
6. Lower hood.

GS25068,00015BD-19-16APR21

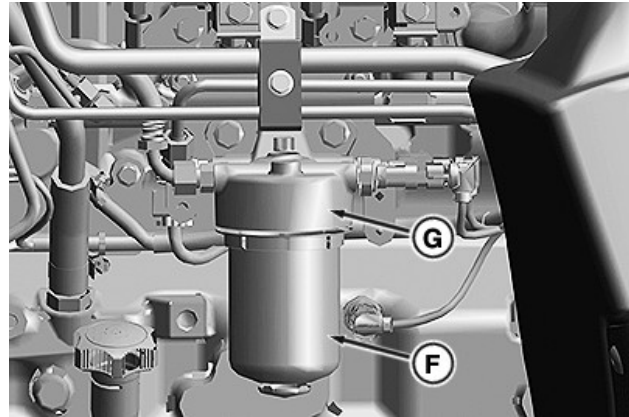

RXA0153078—UN—27JUL16

Left Side of Engine

- A—Water-in-Fuel Sensor
- B—Drain Valve
- C—Water Separator Bowl Assembly
- D—Primary Fuel Filter
- E—Primary Fuel Filter Housing
- F—Secondary Fuel Filter
- G—Secondary Fuel Filter Housing

Change Fuel Filters

MAINTENANCE INTERVAL
Every 500 Hours

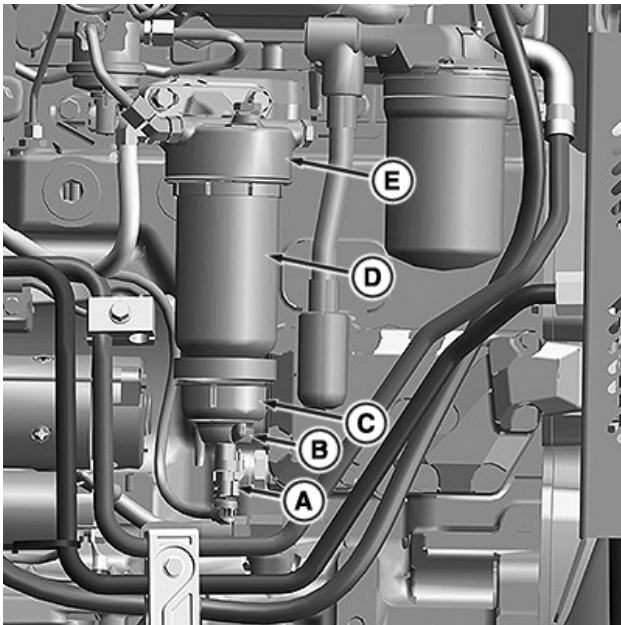

RXA0153077—UN—27JUL16

Right Side of Engine

IMPORTANT: Be sure characteristics of the new filter match the original filter.

The fuel filters (D and F) are different, do not interchange. See your John Deere dealer for correct replacement parts. Replace one after another to avoid interchange.

IMPORTANT: Do not use a filter wrench when tightening filters. Hand tighten filter only.

1. Place machine in park, turn off engine, and remove key. Allow engine to cool.
2. Raise hood.
3. Disconnect water-in-fuel sensor (A) on the bottom of the primary fuel filter on the right-hand side of the engine.
4. Open drain valve (B) on water separator bowl assembly (C) of the primary fuel filter (D). Drain fuel. Capture the discharge waste and dispose of properly.
5. Remove primary filter from the fuel filter housing (E) by turning counterclockwise.
6. Remove water separator bowl assembly from the primary fuel filter.
7. Clean water separator bowl. Dry with compressed air.
8. Install new seals (supplied with the new filter) on the water separator bowl and drain valve. Install water separator assembly on the new primary fuel filter.
9. Fill filters with clean diesel fuel before installing on engine.

10. Apply a small amount of clean oil on the primary fuel filter gasket.
11. Install new primary fuel filter assembly.
12. Connect water-in-fuel sensor.
13. Remove secondary fuel filter (F) on the left-hand side of the engine from the filter housing (G) by turning counterclockwise.

NOTE: Do not fill the secondary fuel filter assembly with fuel when reassembling.

14. Apply a small amount of clean oil on the new secondary fuel filter gasket.
15. Install new secondary fuel filter.
16. Bleed the fuel system. (See Bleed Fuel System in this section.)
17. Start engine and run until warm.
18. Turn off engine and remove key.
19. Inspect drain valve and filters for leaks.
20. Lower hood.

GS25068,00015BE-19-17JUN21

Clean Fuel Tank Vent Filter

MAINTENANCE INTERVAL
Every 1000 Hours or Annually



Left-Hand Side

LV22351—UN—11JUL14

A—Fuel Tank Vent Filter

⚠ CAUTION: Reduce compressed air pressure to less than 210 kPa (2 bar) (30 psi) when using for cleaning purposes. Clear area of bystanders, guard against flying chips, and wear personal protection equipment including eye protection.

NOTE: Fuel tank vent filter is not used on machines equipped with vented fuel caps.

Raise hood and locate fuel tank vent filter (A) on the left-hand side of machine.

1. Unlatch and raise hood.
2. Identify the fuel tank vent filter (A) on the left-hand side of the machine as shown.
3. Remove and clean fuel tank vent filter with a soapy solution.
4. Blow dry with compressed air and inspect it.
5. Reinstall fuel tank filter. If it is damaged, replace it.

GS25068,00015BF-19-16APR21

Check Coolant Level

MAINTENANCE INTERVAL
Weekly or Every 50 Hours

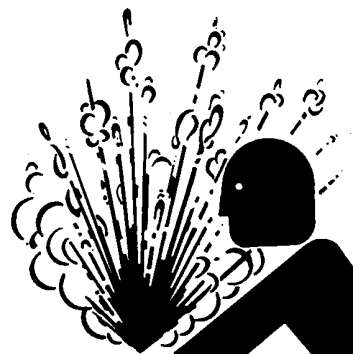

TS281—UN—15APR13

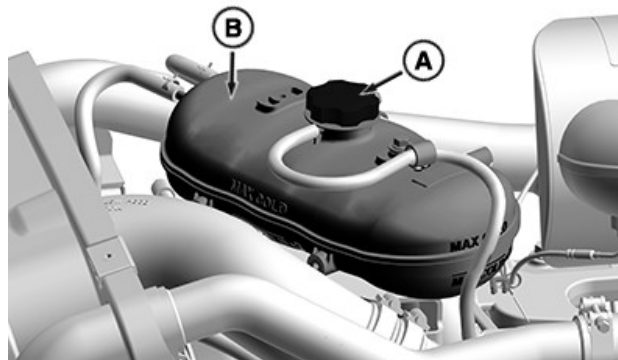

RXA0154402—UN—24FEB17

A—Cap
B—Coolant Recovery Tank

 **CAUTION: Avoid injury from hot, spraying fluid. Add make-up coolant through the coolant recovery tank. If cap must be removed, do not remove when engine is hot. Shut off engine and wait until cap is cool enough to touch with bare hands. Slowly loosen cap to relieve pressure before removing completely.**

1. Park machine on level ground and shut off engine. Remove key.
2. Allow engine to cool completely.
3. Raise hood and check level in the coolant recovery tank (B).
4. If coolant level is below **the MIN COLD** mark, remove cap (A) and add coolant to the recovery tank. Fill tank level between **MIN COLD** and **MAX COLD** marks with Cool-Gard II pre-diluted coolant. (See Fuel, Lubricants, and Coolants section.)
5. Replace cap.
6. Lower hood.

GS25068,00015C0-19-16APR21

Electrical and Lighting Maintenance

Use Booster Battery or Charger



TS204—UN—15APR13

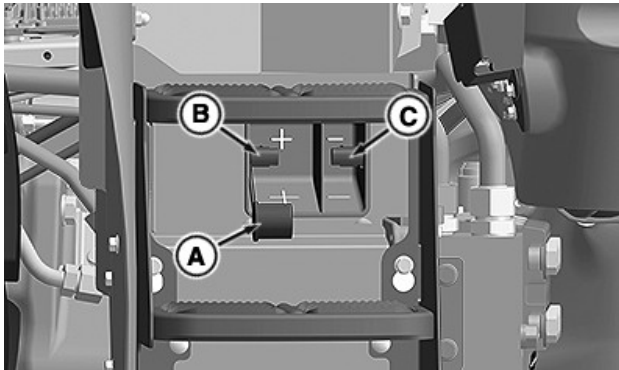

RXA0154359—UN—01NOV16

Under Right-Hand Step

- A—Protective Cover
- B—Positive Terminal
- C—Negative Terminal

CAUTION: Battery gas is explosive. Keep sparks and flames away from battery. Make last connection and first disconnection at a point away from battery.

Booster Battery

1. Remove protective cover (A) from the positive terminal.
2. Attach positive jumper cable to the machine battery positive terminal (B).
3. Attach positive jumper cable to the booster battery positive post.
4. Attach negative jumper cable to the machine battery negative terminal (C).
5. Attach negative jumper cable to the booster battery negative post.
6. Turn key to Start.
7. When engine starts, remove negative jumper cables first, then the positive cables.
8. Reinstall the protective cover on the positive terminal.

Battery Charger

1. Remove protective cover (A) from the positive terminal.
2. Turn charger OFF.
3. Attach positive charger lead to the battery positive terminal (B).
4. Attach negative charger lead to the battery negative terminal (C).
5. Charge battery according to the charger manufacturer's instructions.
6. Turn charger OFF.
7. Disconnect negative charger lead first, then positive lead.
8. Reinstall the protective cover on the positive terminal.

D3K5H22,000058E-19-29MAR21

Check Battery and Connections

MAINTENANCE INTERVAL

Every 1000 Hours or Annually

IMPORTANT: Do not add water in freezing weather unless machine is run at least 30 minutes to assure thorough mixing.

NOTE: Although this battery is a maintenance-free battery, conditions such as long periods of operation at high ambient temperatures and excessive starting could require adding water. See label on the battery.

1. Clean battery and remove debris buildup from top of battery case as needed.
2. Check level of the electrolyte in each cell as needed. Ensure that every cell has fluid level above the top of plates. Only use clean, soft water to fill up electrolyte level.
3. Wipe battery with a damp cloth.
4. Remove, clean, and tighten connections if needed.
5. Coat terminals with a small amount of grease.
6. If battery is not performing as desired, charge as needed or see your John Deere dealer.

GS25068,00015C1-19-16APR21

Access and Replace Battery

Remove Right-Hand Steps

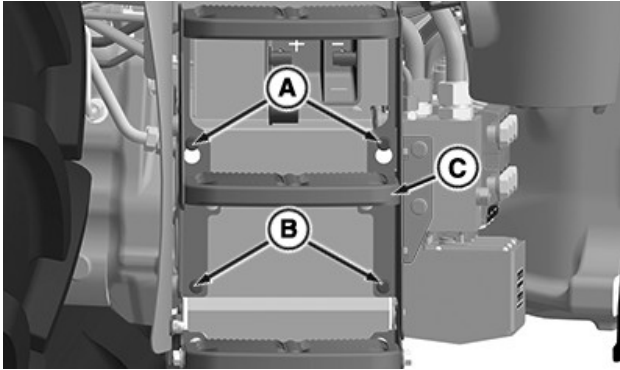

RXA0154360—UN—01NOV16

- A—Position Bolts
- B—Retaining Bolts
- C—Step Assembly

1. Loosen but do not remove position bolts (A).
2. Remove retaining bolts (B).
3. Pull step assembly (C) upward and away from the machine to remove.

Remove Battery Hold-Down Bracket

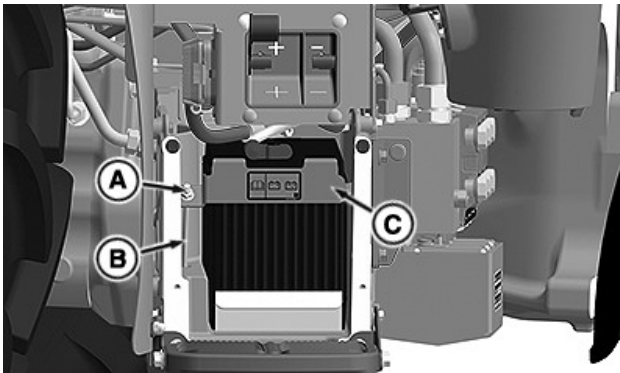

RXA0154410—UN—01NOV16

- A—Nut
- B—Retaining Bolt
- C—Hold-Down Bracket

1. Remove nut (A) from retaining bolt (B).
2. Remove hold-down bracket (C) and retaining bolt.

Remove and Replace Battery

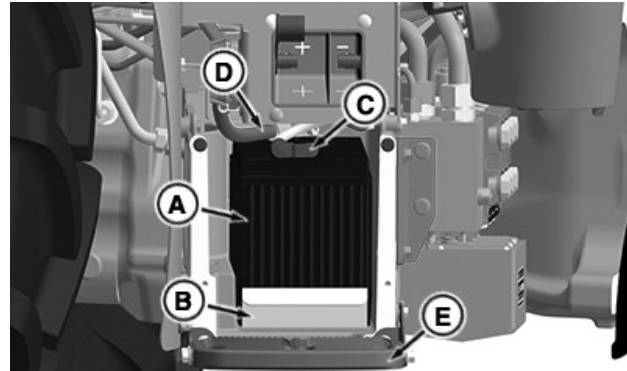

RXA0154411—UN—01NOV16

- A—Battery
- B—Battery Slide-Out Tray
- C—Negative Battery Cable
- D—Positive Battery Cable
- E—Bottom Step

NOTE: Battery cables will not reach battery posts if battery is installed incorrectly. Verify correct battery orientation before replacement.

1. Pull battery (A) and slide-out tray (B) away from the battery compartment.
2. Set battery on bottom step (E).
3. Disconnect the negative battery cable (C).
4. Disconnect the positive battery cable (D).
5. Test or remove battery as required.
6. Replace battery in opposite order of removal.

D3K5H22,000058F-19-29MAR21

Replace Fusible Link

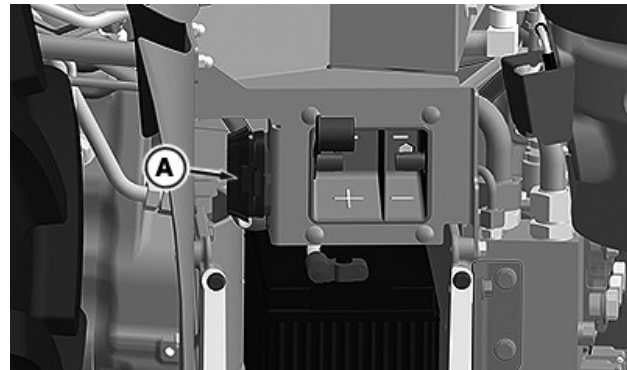

RXA0154412—UN—01NOV16

- A—Fusible Link

1. Access the battery compartment. (See Access and Replace Battery in this section.)
2. Disconnect the battery.
3. Locate the fusible link (A) next to the battery.
4. Open the fusible link cover.

5. Replace the fusible link with a new part from your John Deere dealer.
6. Close cover, reconnect the battery, and reinstall the steps.

D3K5H22,0000590-19-29MAR21

Replace Fuses

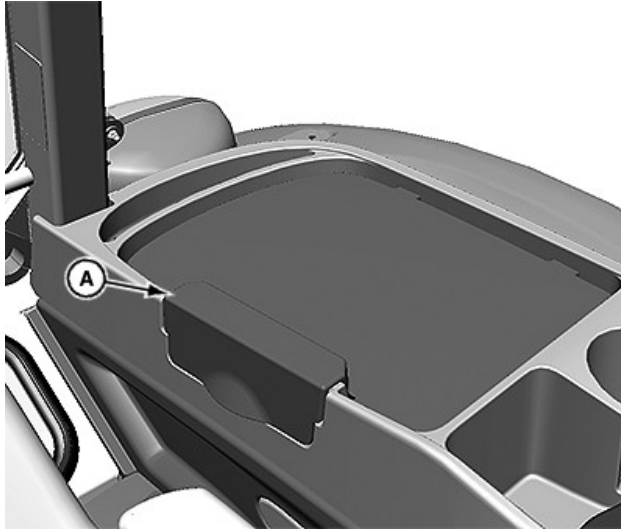

Left Console

LV22822—UN—15AUG14



Fuse/Relay Block

LV14697—UN—25AUG11

A—Left-Hand Console Cover

IMPORTANT: Never replace the original fuse with a higher rated fuse or machine damage will occur. If the original size fuse does not carry electrical load and continues to fail, have the electrical system checked by your John Deere dealer.

NOTE: A fuse and relay reference label is provided under the left-hand console cover (A).

Remove cover (A) to access main fuse, relay load center, and fuse/relay block.

All electrical circuits are protected by fuses. Amperage rating is marked on each fuse. Fuses are color coded to facilitate proper replacement.

Fuse Rating in Amperes	Color
5	Tan
10	Red
15	Blue
20	Yellow
25	Clear
30	Green

NOTE: Most fuses and relays are located in the main load center as shown. Additional relays and a diode block are located inside the front console.

Fuses use an "F" designator and relays use a "K" designator as identifiers.

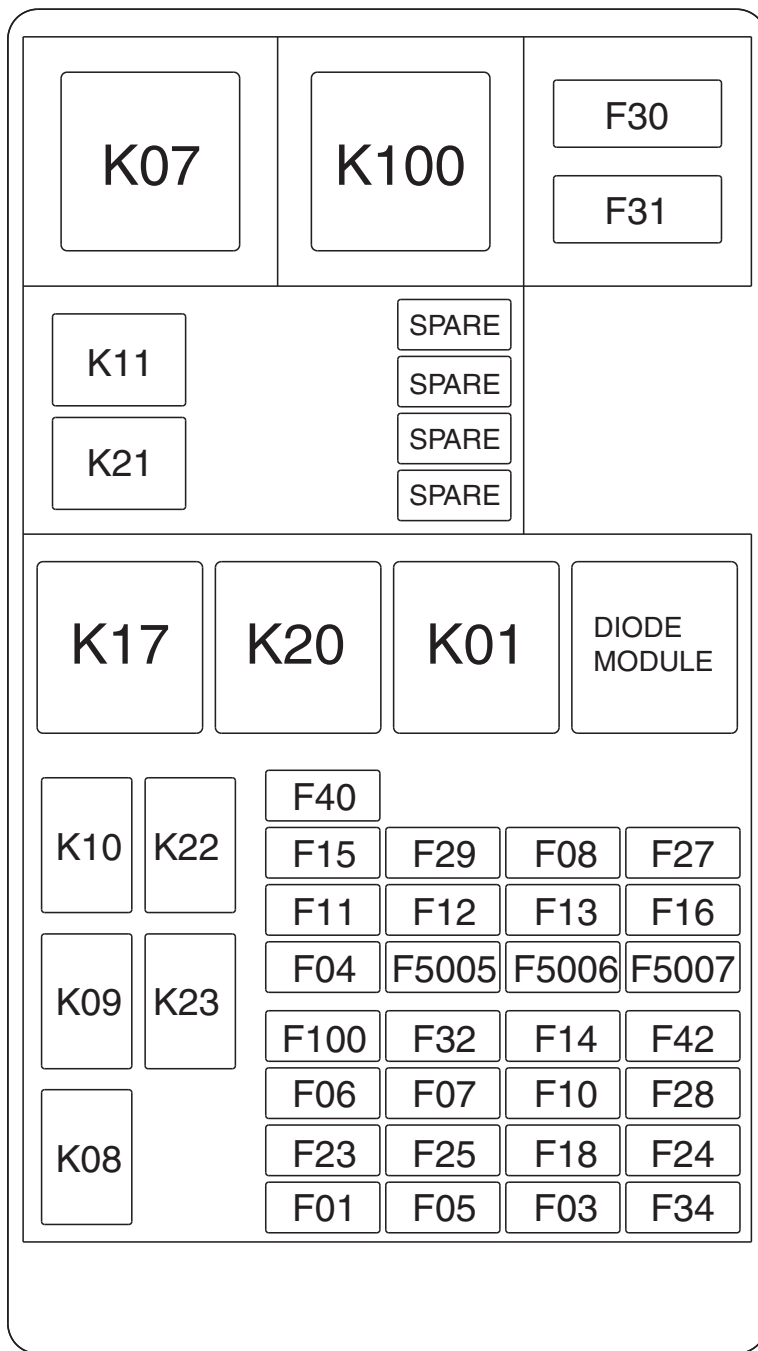

Cab Load Center

RXA0182391—UN—19APR21

- F01—Key Switch
- F03—Seat/Primary Display
- F04—Front PTO (if equipped)
- F05—Brake Lights
- F06—Junction Block Unswitched Power
- F07—Dome Light
- F08—Loader Power (if equipped)
- F10—Implement Power
- F11—Junction Block Switched Power

- F12—Radio (if equipped)
- F13—Seat
- F14—Transmission Controller
- F15—ISO Radio Memory (if equipped)
- F16—Power Outlet
- F18—Beacon Light (if equipped)
- F23—Heating, Ventilation, and Cooling/Right Blower
- F24—Wiper
- F25—Left Blower

F27—Backup Alarm (if equipped)
 F28—ISOBUS Controller (if equipped)
 F29—Accessory Power
 F30—ISOBUS ECU (if equipped)
 F31—ISOBUS Implement (if equipped)
 F32—Subwoofer Power (if equipped)
 F34—Come Home
 F40—Radio Memory (if equipped)
 F42—ISOBUS (if equipped)
 F100—Trailer Lights
 F5005—Engine Control Unit Power
 F5006—Engine Control Unit Power
 F5007—Engine Control Unit Power
 K01—ISOBUS ECU Power (if equipped)

K07—Accessory Power
 K08—Trailer Worklights
 K09—Brake Lights
 K10—Beacon Light (if equipped)
 K11—Neutral
 K17—Implement Power
 K20—Heating, Ventilation, and Cooling
 K21—Wiper
 K22—Left-Hand Blower
 K23—Right-Hand Blower
 K100—ISOBUS Implement Power (if equipped)
 Diode Module—Block of Diodes
 Spare—Extra Fuses (if equipped)

HV12280,0000B96-19-24MAY23

Handle Halogen Light Bulbs Safely

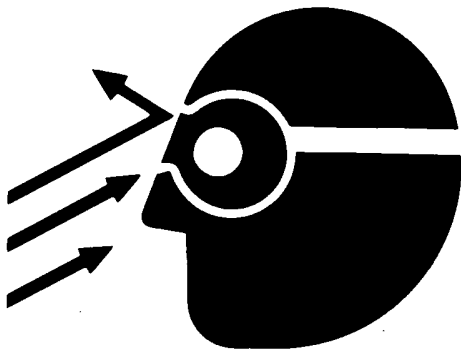

TS266—UN—23AUG88



H39474—UN—30JUN00

A—Halogen Bulb

⚠ CAUTION: Halogen bulbs (A) contain gas under pressure. Handling a bulb improperly could cause it to shatter into flying fragments. To avoid possible injury:

- Handle bulb by its base. Keep bulb oil free; wear gloves to avoid touching glass.
- Turn light switch off and allow bulbs to cool before changing. Leave switch off until bulb change is done.
- Wear eye protection.
- Do not drop or scratch bulb. Keep moisture away from bulb.
- Place used bulb in the new bulb carton and

dispose of properly. Keep out of the reach of children.

DP51502,0002BA2-19-06APR17

Replace Halogen Headlight Bulb

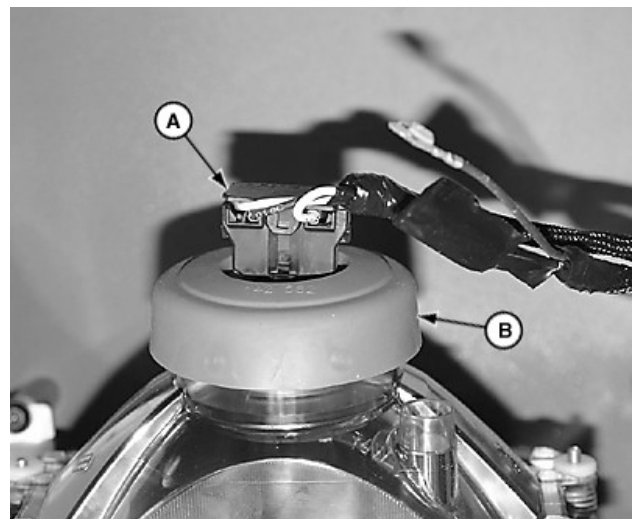

LV14699—UN—25AUG11

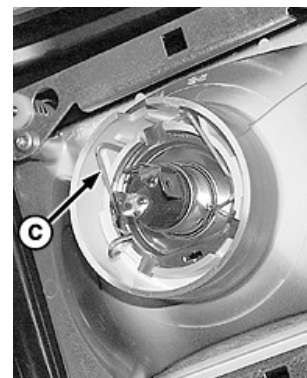

LV9511—UN—01AUG04

A—Wiring Harness Plug
 B—Dust Boot
 C—Retaining Spring

⚠ CAUTION: See Handle Halogen Light Bulbs Safely in this section.

1. Raise hood.
2. Disconnect wiring harness plug (A).
3. Remove dust boot (B).
4. Unlatch retaining spring (C) and remove light bulb.
5. Install new bulb in reverse order of removal.
6. Adjust headlights, if necessary.

GS25068,0000D01-19-06FEB20

- A—Harness Connector
- B—Light Retaining Screws
- C—LED Headlight Bulb
- D—Backing Plate Screw
- E—Backing Plate

1. Raise hood.
2. Disconnect wiring harness connector (A).
3. Remove light retaining screws (B).
4. Remove LED headlight bulb (C).
5. Remove screws (D) from backing plate (E).
6. Replace headlight bulb with a new part and reassemble in reverse order.

DP51502,0002BA4-19-17MAR17

Replace LED Headlight

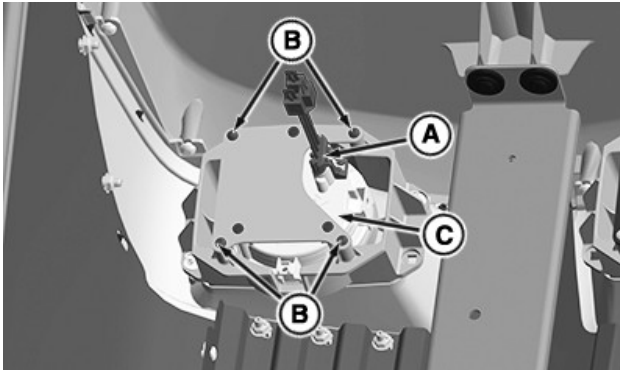

RXA0154413—UN—01NOV16

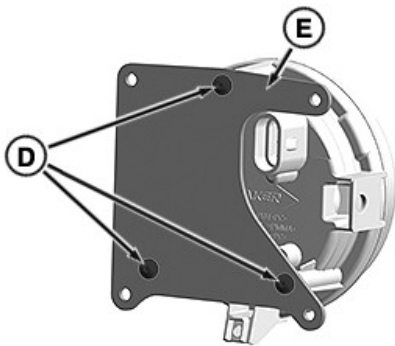

RXA0154414—UN—01NOV16

Headlight Adjustment

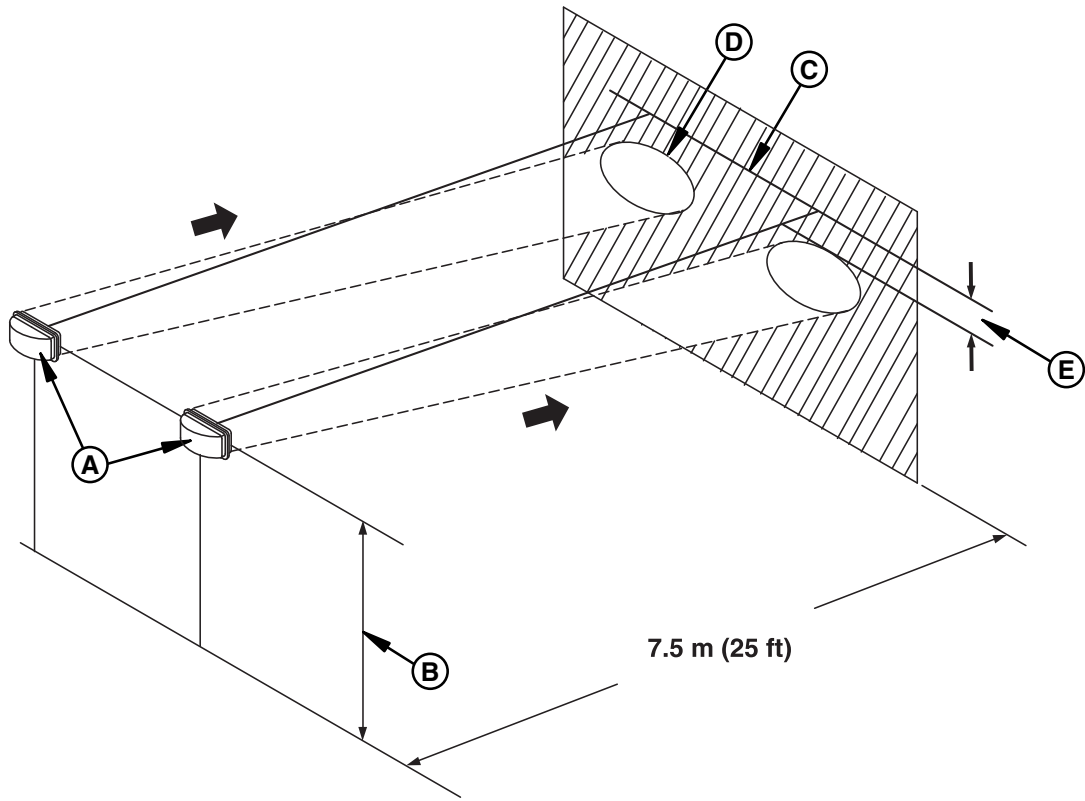

Headlight Aiming Diagram

PULV000659—UN—05MAY08

A—Headlights
B—Distance from Center of Headlight to Ground
C—Horizontal Line on Wall

D—Border of Bright Area
E—10% of Distance (B)

1. Park machine on a level surface with headlights (A) 7.5 meters (25 ft) from a vertical wall.
2. Measure the distance (B) from the center of a headlight to the ground.
3. Mark a horizontal line (C) on the wall, the same distance from the ground as (B).
4. Turn headlight switch to low beam and observe bright areas on the wall.
5. Use screws at the back of lights for adjustment.

GS25068,00015C4-19-19APR21

Replace Loader Headlight Bulb

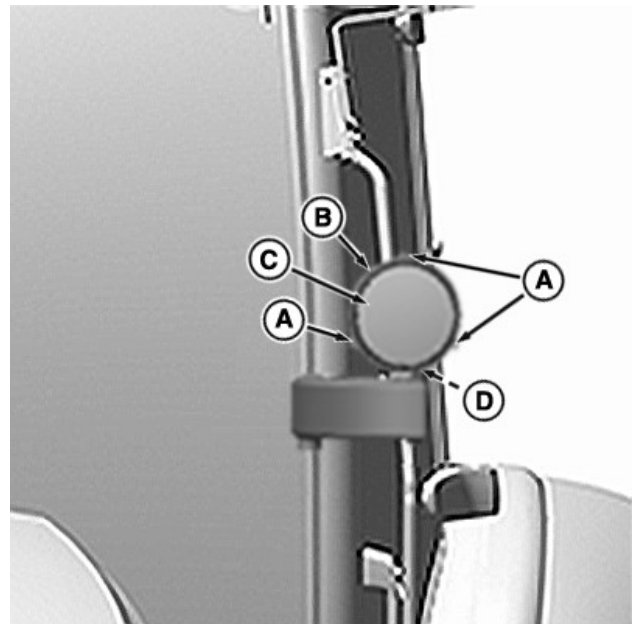

A—Retaining Ring Screws
B—Retaining Ring

RXA0156148—UN—12DEC16

C—Lens
D—Harness Connector

1. Disconnect harness connector (D).
2. Remove retaining ring screws (A) and retaining ring (B).
3. Pull bulb to remove from socket.
4. Install new bulb in socket.
5. Reinstall in reverse order.

GS25068,00015C5-19-19APR21

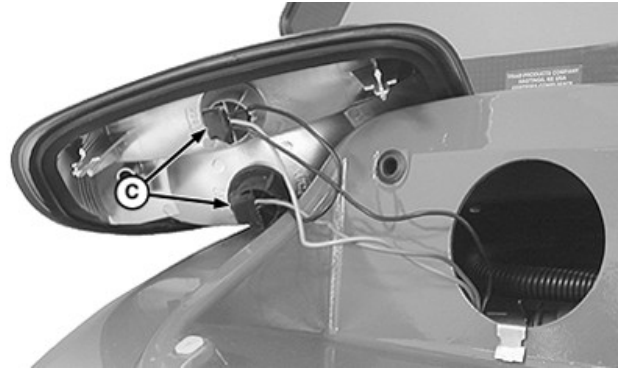

LV12532—UN—13APR05

A—Screw (2)
B—Housing
C—Socket (2)

1. Remove screws (A).
2. Pull housing (B) away from fender.
3. Rotate socket (C) and remove from housing.
4. Pull bulb to remove from socket.
5. Install new bulb in socket.
6. Reinstall in reverse order.

GS25068,00015C2-19-19APR21

Replace Bucket Light

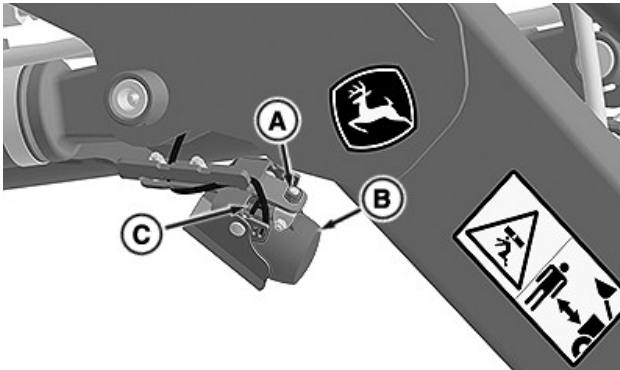

RXA0158319—UN—22MAR17

A—Nut
B—Light Fixture
C—Wire Harness

1. Remove nut (A).
2. Remove light fixture (B).
3. Disconnect wiring harness (C).
4. Install new light fixture in reverse order.
5. Adjust, if necessary.

DP51502,0002BA6-19-17MAR17

Replace Warning Light Bulb



RXA0182390—UN—01APR21

Replace Tail/Turn/Brake Light Bulb

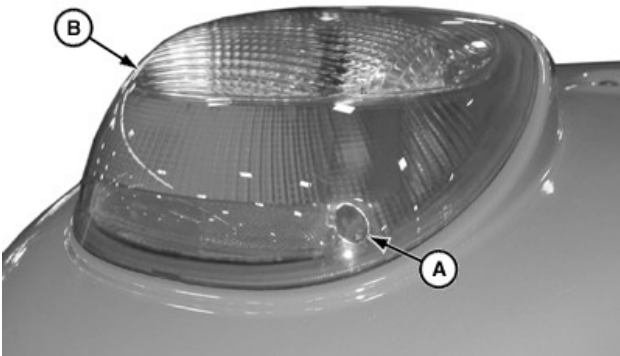

LV14850—UN—04OCT11

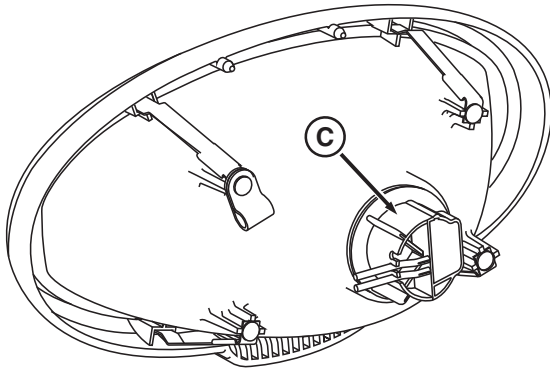

- A—Mounting Screw (2)
- B—Housing
- C—Bulb and Socket

RXA0181720—UN—12APR21

NOTE: Bulb replacement procedures for front and rear warning lights are the same.

1. Remove mounting screws (A) securing housing (B) to cab roof.
2. Remove bulb and socket (C) from housing.
3. Pull bulb from socket.
4. Install new bulb and socket into housing.

NOTE: Apply thread lock and sealer (medium strength) to mounting screws (A) if equipped with auxiliary worklights.

5. Install housing and screws to cab roof.

GS25068,00015C6-19-19APR21

Replace Halogen Worklight Bulb

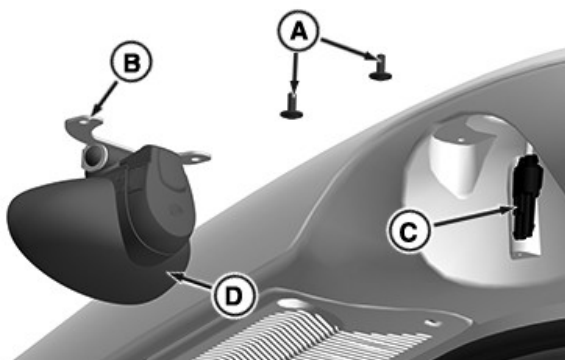

- A—Screws

RXA0154417—UN—07NOV16

- B—Bracket
- C—Harness Connector
- D—Halogen Light Housing

CAUTION: Halogen bulbs contain gas under pressure. Handling a bulb improperly could cause it to shatter into flying fragments. (See Handle Halogen Light Bulbs Safely in this section.)

NOTE: Bulb replacement procedures for front, side, rear, and auxiliary worklights are the same.

1. Tilt halogen light housing outward and remove screws (A) from the light bracket (B).
2. Disconnect harness connector (C) from the light housing (D). A protective connector cover may need to be removed.
3. Rotate bulb and remove from housing.
4. Install new bulb in the housing.
5. Reinstall housing in reverse order of removal.

D3K5H22,000059C-19-07APR21

Replace LED Worklight

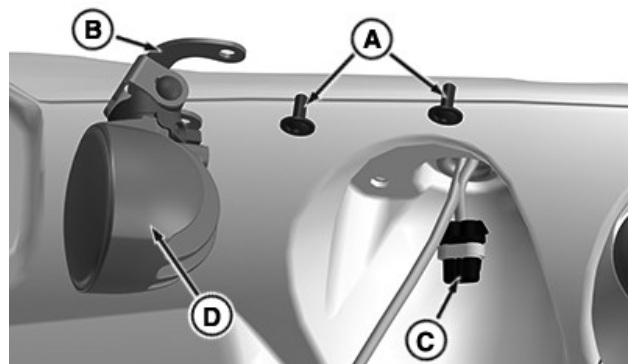

RXA0154416—UN—07NOV16

- A—Screws
- B—Bracket
- C—Harness Connector
- D—LED Light Bulb

NOTE: Bulb replacement procedures for front, side, rear, and auxiliary worklights are the same.

1. Tilt LED light housing outward and remove screws (A) from the light bracket (B).
2. Disconnect harness connector (C) from light bulb (D).
3. Replace LED light bulb.
4. Reinstall housing in reverse order of removal.

D3K5H22,000059D-19-07APR21

Replace LED Beacon Light



RXA0182393—UN—06APR21



A—Screws (3)
B—Wire Harness

1. Remove screws (A) from top of beacon light assembly.
2. Disconnect wire harness (B) and remove beacon light assembly.
3. Install new beacon light assembly in reverse order of removal.

GS25068,00015C7-19-19APR21

Replace Dome Light Bulb

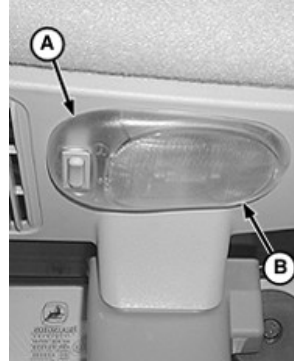

LV12533—UN—13APR05

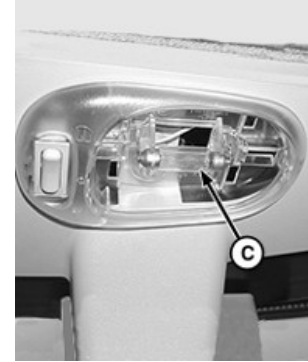

LV12534—UN—13APR05

A—Housing
B—Cover
C—Bulb

1. Remove cover (B) from housing (A).
2. Pull bulb (C) from socket.
3. Install new bulb and cover.

DP51502,0002BAB-19-20MAR17

Replace Map Light Bulb

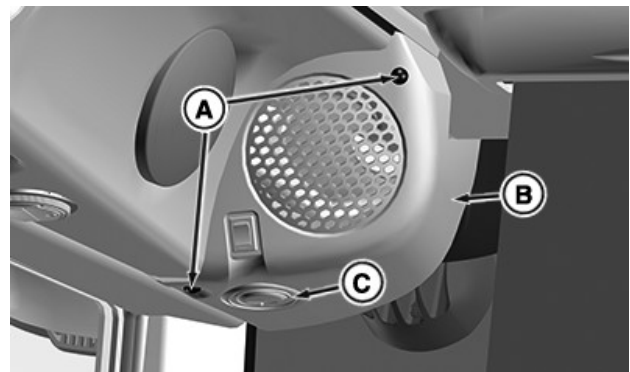

RXA0154420—UN—07NOV16

A—Screw (2)
B—Cover
C—Map Light

1. Remove screws (A) from cover (B).
2. Lower cover to access harness connector of map light (C).
3. Pull bulb from back side of the light housing.
4. Install new bulb in reverse order of removal.

GS25068,00015C8-19-19APR21

Replace Right-Hand Console Light Bulb

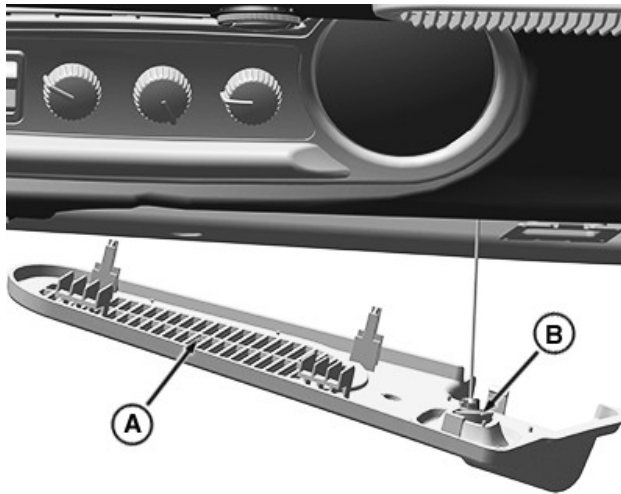

RXA0153099—UN—29JUL16

A—Panel
B—Light Bulb Retainer

1. Pry off panel (A).
2. Rotate light bulb retainer (B) counterclockwise to remove.
3. Pull out light bulb.
4. Install new bulb in reverse order of removal.

DP51502,0002BAC-19-20MAR17

Drivetrain Maintenance

Drivetrain Information

The drivetrain information is broken up into different functional systems for operation and maintenance. See the following sections within this manual for detailed information:

Operational Sections

- Transmission Operation
- MFWD and Front Axle Operation
- Differential and Rear Axle Operation
- Power Take-Off (PTO) Operation

Maintenance Sections

- Transmission Maintenance
- MFWD and Front Axle Maintenance
- Differential and Rear Axle Maintenance
- Power Take-Off (PTO) Maintenance

GS25068,0005437-19-20SEP18

Transmission Maintenance

Change Transmission/Hydraulic Oil and Filter

See Hydraulics Maintenance section for procedure.

GS25068.0005438-19-20SEP18

Check Neutral Start System

MAINTENANCE INTERVAL

Every 500 Hours



RXA0182233—UN—19APR21



RXA0182234—UN—19APR21

A—Range Shift Lever
B—Left-Hand Reverser

CAUTION: If machine starts while left-hand reverser is held in Forward or Reverse position, see your John Deere dealer immediately for repairs.

CAUTION: If PTO rotates when starting engine, see your John Deere dealer immediately for repairs.

Transmission Check

IMPORTANT: Engine should start with transmission in NEUTRAL or PARK positions only.

1. Shut off the engine.
2. Depress the clutch pedal and brake pedals.

3. Place the range shift lever (A) in any range. Range shift lever must not be in neutral or park.

4. Place the left-hand reverser (B) into forward or reverse direction position.

5. Attempt to start the engine.

PTO Check

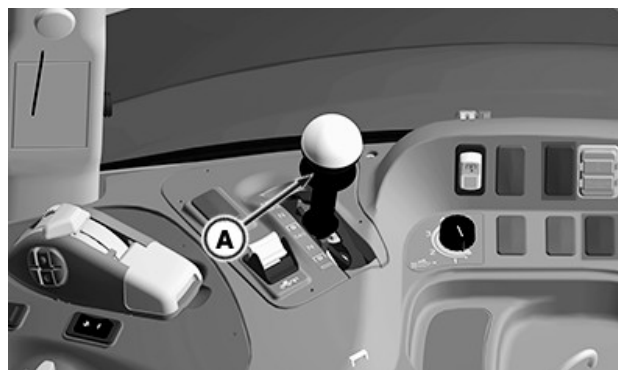

RXA0182235—UN—19APR21

A—Shiftable PTO Speed Lever

1. Shut off the engine.
2. Place the range shift lever in neutral or park.
3. Place shiftable PTO speed lever (A) into any speed.
4. Switch rear PTO engagement switch in the engaged position.
5. Start the engine. Engine starts but rear PTO does not rotate.
6. Shut off the engine. Shift the PTO speed lever into another speed and repeat steps 1—5.

GS25068.00015C9-19-29JUL21

Check Transmission Park System



RXA0182233—UN—19APR21

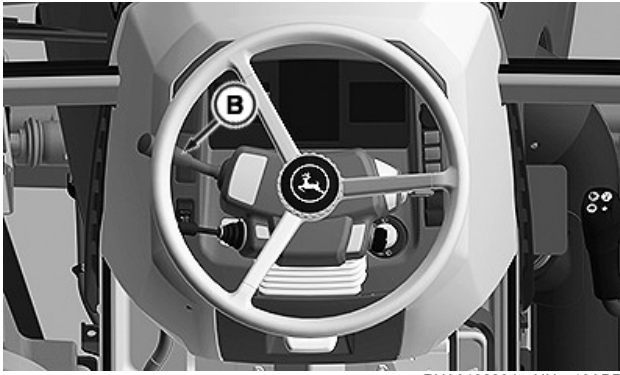

RXA0182234—UN—19APR21

A—Range Shift Lever
B—Left-Hand Reverser

⚠ CAUTION: Avoid personal injury. Make sure that everyone is clear of machine.

If machine does not hold stationary on an incline with reverser lever in Park position, see your John Deere dealer immediately for repairs.

1. Position machine on a 30% incline (1 m [3.3 ft] vertically for every 3 m [9.8 ft] horizontally) with the front of machine facing downward.
2. Depress the clutch pedal and brake pedals.
3. Place the range shift lever (A) in park.
4. Place the left-hand reverser (B) in neutral.
5. Release the clutch pedal and brake pedals. Wait 10—15 seconds, watching for movement.

GS25068,00015CA-19-20APR21

Change Transmission Dampener

MAINTENANCE INTERVAL Every 4500 Hours or 5 Years
--

Have your John Deere dealer inspect and service the transmission dampener.

GS25068,00015CB-19-19APR21

MFWD and Front Axle Maintenance

Lubricate MFWD Axle Trunnion

MAINTENANCE INTERVAL

Weekly or Every 50 Hours

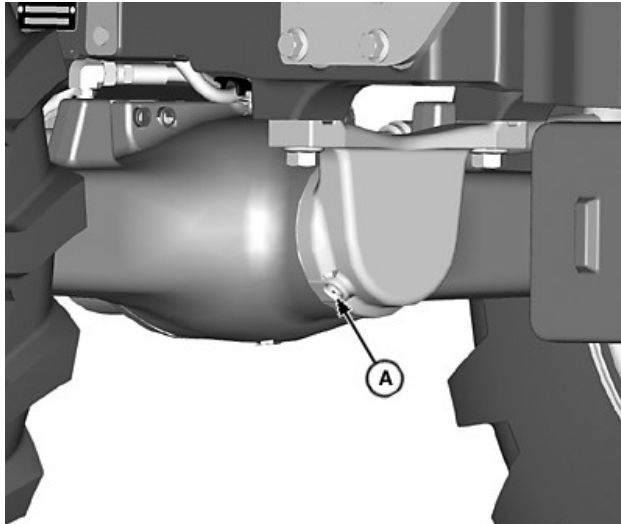

LV14409—UN—08JUN11

Front Side of Axle

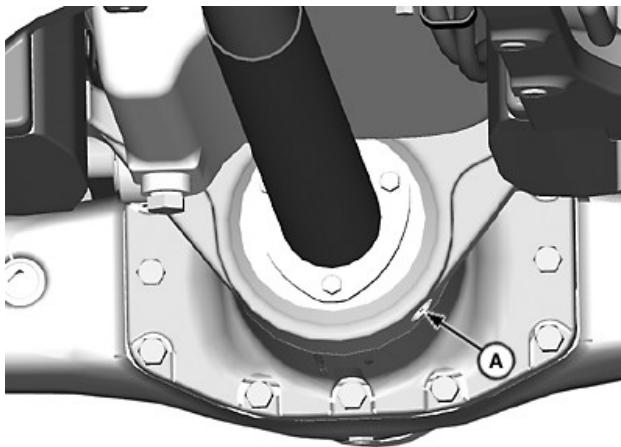

LV14410—UN—08JUN11

Back Side of Axle

A—Trunnion Grease Points

Apply several shots of multi-purpose grease to trunnion. (See Fuel, Lubricants, and Coolants section.)

GS25068,00015CC-19-19APR21

Change MFWD Axle Wheel Hub Oil

MAINTENANCE INTERVAL

Every 500 Hours

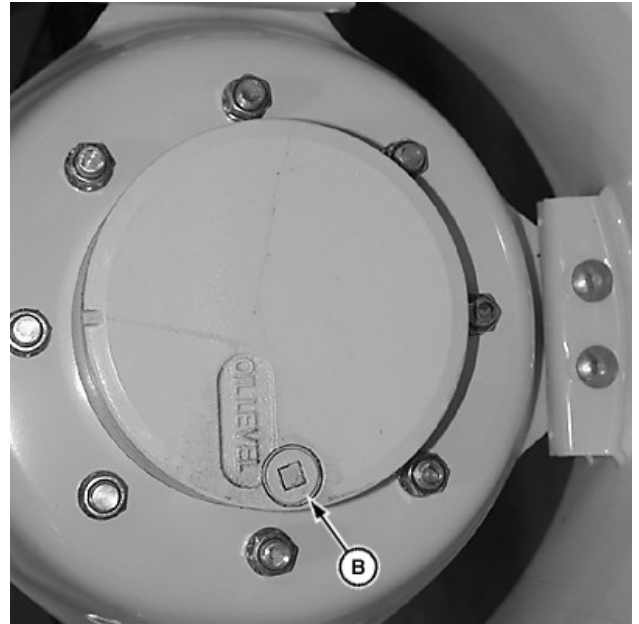

LV15529—UN—05MAR12

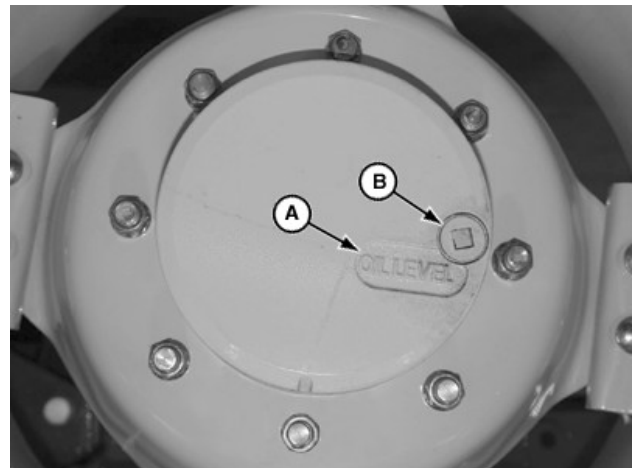

LV14649—UN—18AUG11

A—Oil Level
B—Drain/Fill Port Plug

NOTE: Approximate oil capacity for MFWD hubs is 0.8 L (0.9 qt). (See Fuel, Lubricants, and Coolants section.)

1. Park machine on a level surface, with wheel rotated until drain/fill port plug (B) is at bottom of hub.
2. Remove drain/fill port plug and drain oil.
3. After oil has drained, move and park machine so that "OIL LEVEL" mark at the drain/fill port is parallel to ground.
4. Add Hy-Gard J20C until it reaches oil level (A) at bottom of the drain/fill port.
5. Install drain/fill port plug (B) and tighten to specifications.

Specification

Plug to Hub—Torque. 70 N·m
(52 lb·ft)

GS25068,00015CD-19-19APR21

Change MFWD Axle Housing Oil

MAINTENANCE INTERVAL
Every 500 Hours

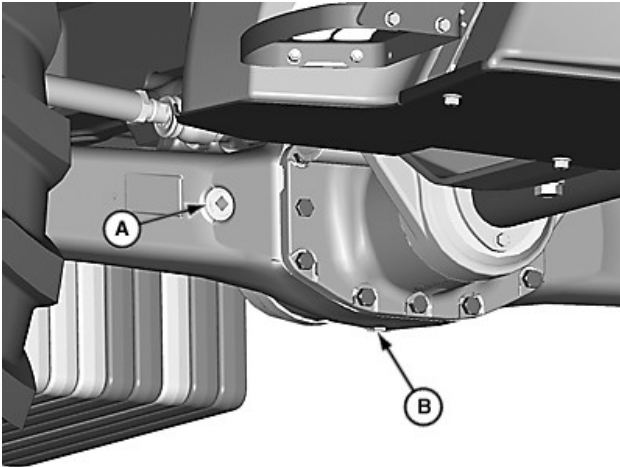

LV14651—UN—17AUG11

A—Fill Plug
B—Drain Plug

NOTE: Approximate MFWD axle housing oil capacity is 5 L (1.3 gal). (See Fuel, Lubricants, and Coolants section.)

1. Park machine on level ground. Remove key.
2. Remove fill plug (A) and drain plug (B).
3. Install drain plug and tighten to specification.
4. Add Hy-Gard J20C until even with the bottom of fill plug.
5. Install the fill plug and tighten to specification.

Specification

Plug to Housing—Torque. 70 N·m
(52 lb·ft)

GS25068,00015CE-19-19APR21

Differential and Rear Axle Maintenance

Lubricate Rear Axle Bearings

MAINTENANCE INTERVAL Every 500 Hours
--

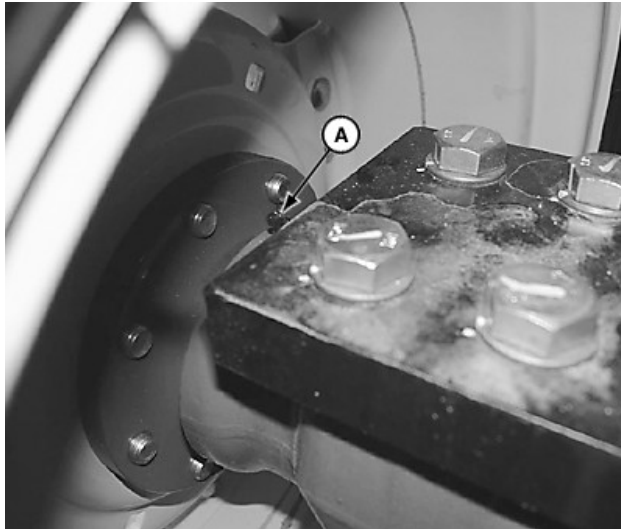

LV14653—UN—17AUG11

A—Grease Point

NOTE: Service more often if operated in wet and muddy conditions.

Lubricate rear axle grease points (A) on left and right-hand sides of the axle with several shots of multipurpose grease. (See Fuel, Lubricants, and Coolants section.)

HV12280,00008F5-19-02DEC20

Power Take-Off (PTO) Maintenance

Adjust PTO Speed Shift Lever

Have your John Deere dealer check and adjust PTO speed shift lever.

DP51502,0002AF1-19-02FEB17

Lubricate Exchangeable 540/1000 rpm PTO Shaft (If Equipped)

MAINTENANCE INTERVAL

Every 1000 Hours or Annually

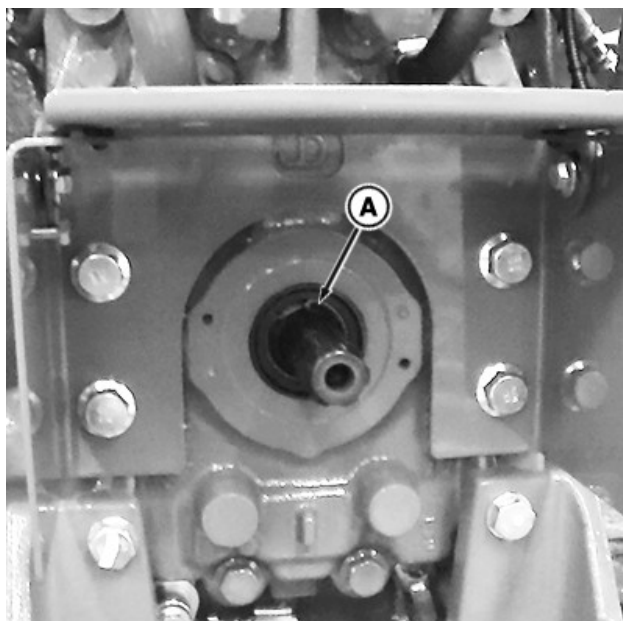

RXA0155648—UN—11NOV16

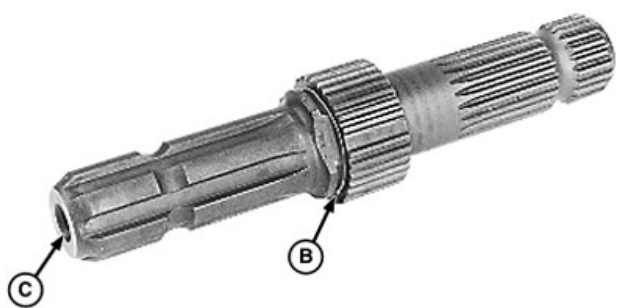

LV12604—UN—26APR05

A—Snap Ring
B—Stub Shaft
C—Bore

IMPORTANT: Ensure that PTO is stopped and allowed to cool before servicing.

NOTE: When exchanging the PTO shaft, hydraulic oil does not leak out due to a dry socket design.

1. Locate flattened area on the stub shaft which facilitates snap ring removal and installation.

2. Align snap ring ends with flattened area. Remove snap ring (A) and pull out PTO shaft (B).
3. Clean PTO shaft thoroughly and apply a light coat of grease. Be sure the end bore (C) is clean if installing shaft for 1000 rpm operation.
4. Turn PTO shaft end-for-end and insert in the PTO housing until snap ring groove is visible.
 - a. **540 rpm shaft**—Rotate the shaft back and forth while installing. Ensure that the shaft is properly seated in housing; continue to push shaft in when installing snap ring.
 - b. **1000 rpm shaft**—Rotate the shaft back and forth while installing until engagement is felt.
5. Install snap ring in the groove to retain PTO stub shaft. Align ends of the snap ring with flat surface of shaft.

GS25068,00015CF-19-02JUN23

Change Front PTO Oil

MAINTENANCE INTERVAL

Every 1000 Hours or Annually

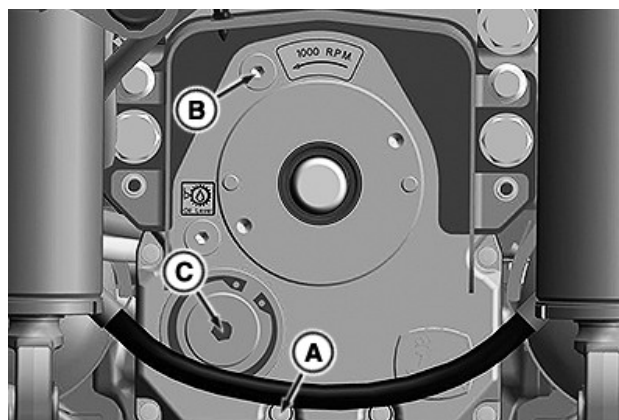

RXA0155640—UN—10NOV16

A—Drain Plug
B—Fill Plug
C—Cover

IMPORTANT: J20D is the only acceptable transmission/hydraulic oil for use in the front PTO.

1. Remove fill plug (B).
2. Remove drain plug (A).
3. Drain oil into a suitable container.
4. Remove snap ring and cover (C).
5. Remove and clean oil screen.
6. Check O-ring, install oil screen, close cover, and install snap ring.

7. Install drain plug (A) and tighten to specification.

Specification

Drain Plug—Torque. 42 N·m
(31 lb·ft)

8. Add J20D transmission/hydraulic oil to the PTO housing. (See Fuel, Lubricants, and Coolants section.)

Specification

Front PTO—Capacity. 3.1 L
(0.8 gal)

9. Install fill plug (B) and tighten to specification.

Specification

Fill Plug—Torque. 42 N·m
(31 lb·ft)

10. Check fluid level after changing oil and after initial run.

GS25068,00015D0-19-19APR21

Steering and Brake Maintenance

Check Manual Brakes

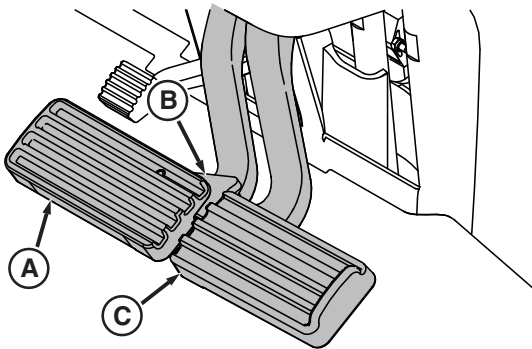

RXA0068386—UN—27AUG03

A—Left Brake Pedal
B—Latch Bar
C—Right Brake Pedal

IMPORTANT: Any noticeable pedal drift downward from initial point of resistance (solid pedal) indicates brake leakage. See your John Deere dealer.

1. Machine must be in park with engine shut off to check brakes for correct function.
2. Position latch bar (B) to allow brake pedals to operate separately.
3. Pump the left brake pedal (A) and right brake pedal (C) individually. Pedals should have a solid feel. If pedals do not feel solid, have your John Deere dealer bleed brakes.
4. Check to make sure that pedals do not settle to end of stroke within 10 seconds after being applied. If leakage exceeds this rate or if one pedal settles faster than the other, see your John Deere dealer.

DP51502,0002AF3-19-02FEB17

Hydraulics Maintenance

Check Transmission/Hydraulic System Oil Level

MAINTENANCE INTERVAL

Weekly or Every 50 Hours

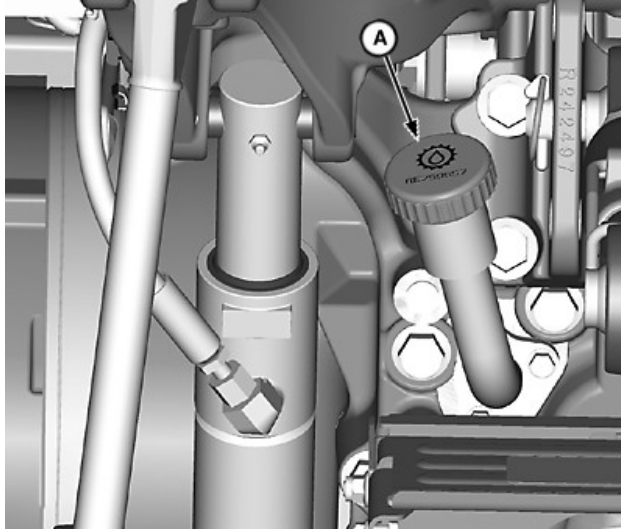

LV14405—UN—08JUN11

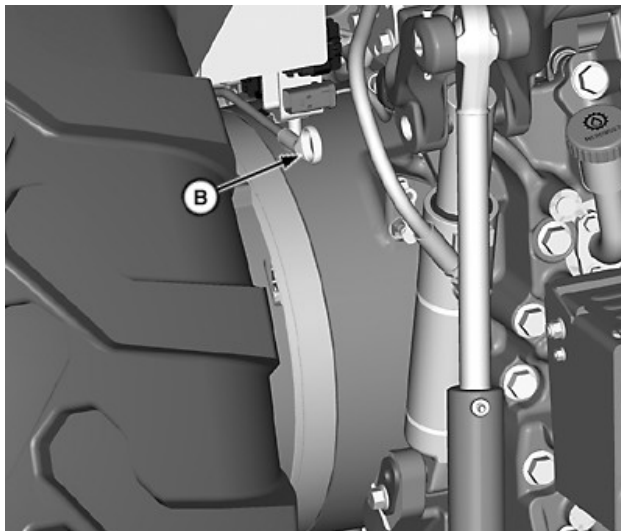

LV14406—UN—08JUN11

A—Transmission Oil Fill Cap
B—Dipstick

1. Park machine on level ground, lower hitch, and other hydraulic implements.
2. Shut off engine. Remove key.
3. Let oil settle for a minimum of five minutes.
4. Check level at the mark on dipstick (B). Level must be at the full oil level mark.
5. Remove transmission oil fill cap (A) and add transmission oil to the fill port if level is low. (See Fuel, Lubricants, and Coolants section for correct oil.)

GS25068,00015D1-19-19APR21

Change Transmission/Hydraulic Filter

MAINTENANCE INTERVAL

INITIAL — 100 Hours

REGULAR (AFTER INITIAL CHANGE) — Every 500 Hours

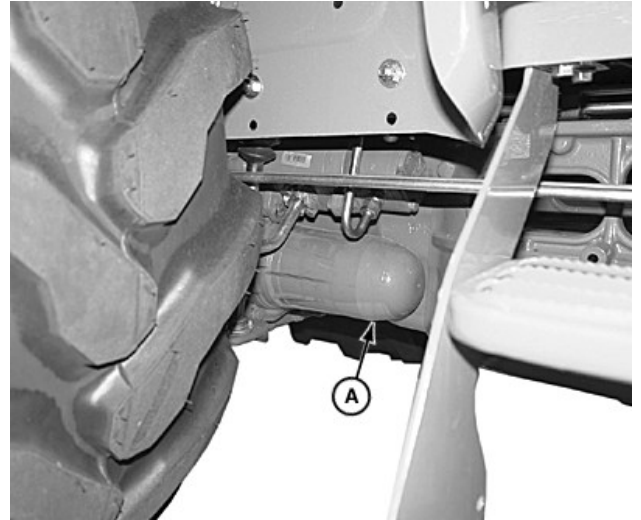

LV14613—UN—11AUG11



LV14782—UN—16SEP11

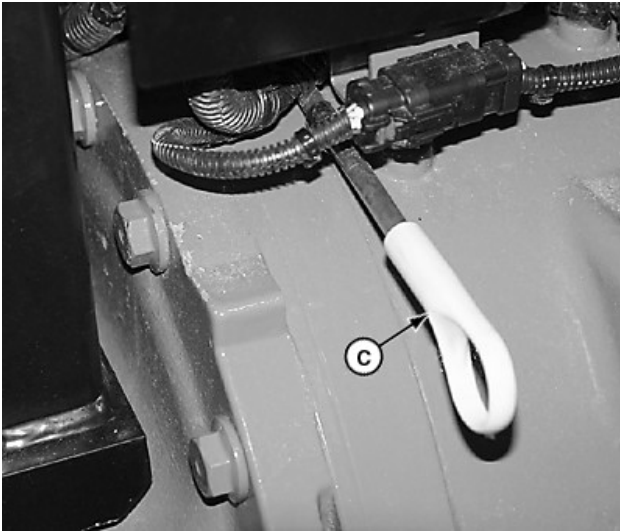

LV14783—UN—16SEP11

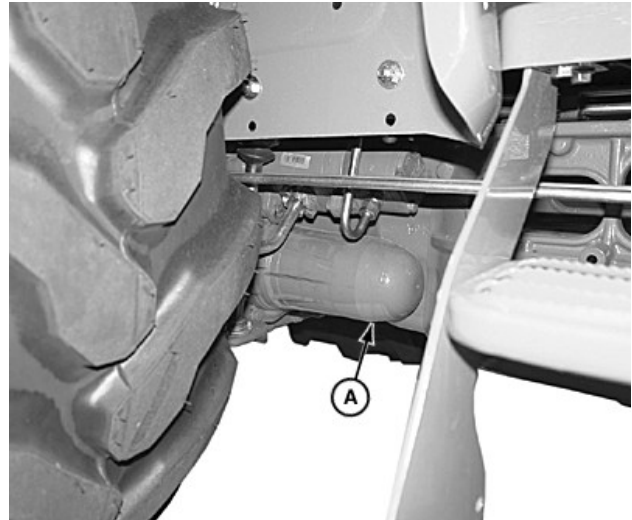

LV14613—UN—11AUG11

- A—Transmission/Hydraulic Oil Filter
- B—Transmission Oil Fill Cap
- C—Transmission Oil Dipstick

IMPORTANT: Capture oil from filter using a drain pan. Dispose of waste oil properly.

IMPORTANT: Do not overtighten filter.

1. Park machine on level ground and shut off engine. Remove key.
2. Remove transmission oil fill cap and use a shop-vac to apply suction to the fill port to prevent excessive draining of hydraulic fluid.
3. Remove transmission/hydraulic oil filter (A) from the filter base.
4. Clean threads on the filter base and on new filter.
5. Apply oil to the new filter seal and install transmission/hydraulic oil filter. Tighten filter by hand, then tighten an additional 1/8 turn.
6. Check oil level with transmission oil dipstick (C).
7. If level is low, remove transmission oil fill cap (B) and add transmission/hydraulic oil as necessary to fill system. (See Fuel, Lubricants, and Coolants section for correct oil.)
8. Recheck oil level after five minutes of operation.

GS25068,00015D2-19-19APR21

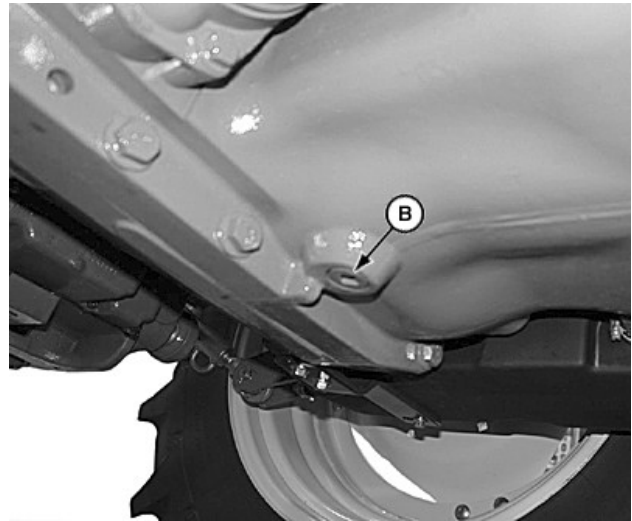

LV14662—UN—18AUG11

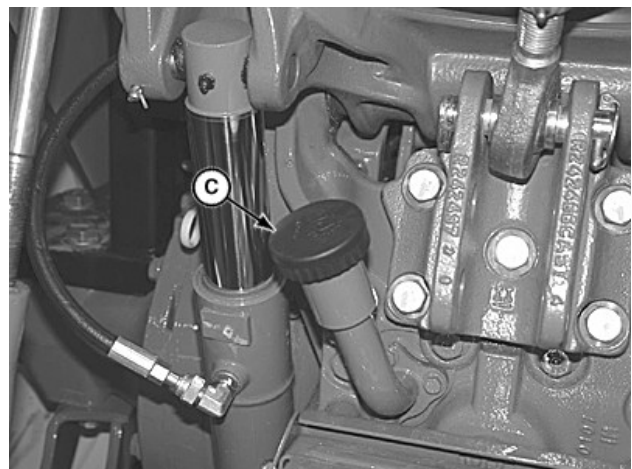

LV14663—UN—18AUG11

Change Transmission/Hydraulic Oil and Filter

MAINTENANCE INTERVAL
Every 1500 Hours

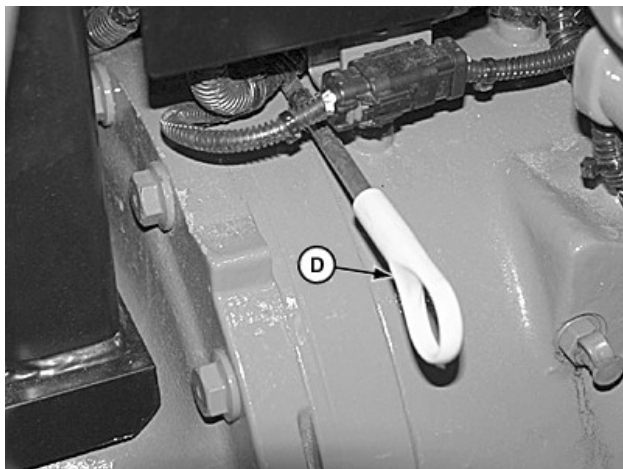

LV14665—UN—18AUG11

- A—Transmission/Hydraulic Oil Filter
- B—Transmission Drain Plug
- C—Transmission Oil Fill Cap
- D—Transmission Oil Dipstick

IMPORTANT: Capture oil from reservoir and filter using a drain pan. Dispose of waste oil properly.

IMPORTANT: Do not overtighten filter.

1. Lower rear hitch to remove trapped oil.
2. Park machine on level ground and shut off engine. Remove key.
3. Remove transmission drain plug (B).
4. Remove transmission/hydraulic oil filter (A) from the filter base.
5. Clean threads on the filter base and on the new transmission/hydraulic oil filter with clean transmission/hydraulic oil.
6. Apply oil to the new transmission/hydraulic oil filter seal and install transmission/hydraulic oil filter. Tighten transmission/hydraulic oil filter by hand, then tighten an additional 1/8 turn.
7. Install transmission drain plug.
8. Remove transmission oil fill cap (C) and fill oil. (See Fuel, Lubricants, and Coolants section for correct oil.)

Specification

Transmission Oil—Capacity 39.4 L
(10.4 gal)

9. Check oil level with transmission oil dipstick (D) and again after five minutes of operation.

GS25068,00015D3-19-19APR21

Hitch and Drawbar Maintenance

Lubricate Draft Sensing Shaft Seal

MAINTENANCE INTERVAL
Every 250 Hours

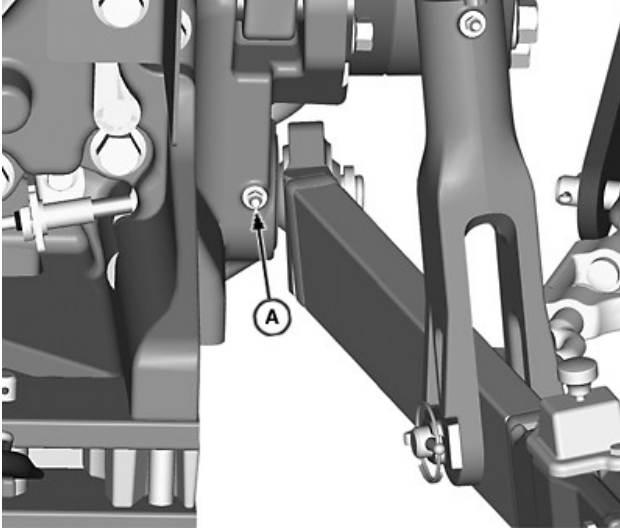

LV14423—UN—13JUN11

A—Grease Point

NOTE: Grease point on the right side of the PTO housing shown, left side similar.

Grease daily if operated in wet and muddy conditions.

Apply several shots of general-purpose grease to the grease point (A). (See Fuel, Lubricants, and Coolants for correct lubricant.)

HV12280,00008FB-19-02DEC20

Lubricate Rear Hitch

MAINTENANCE INTERVAL
Weekly or Every 50 Hours

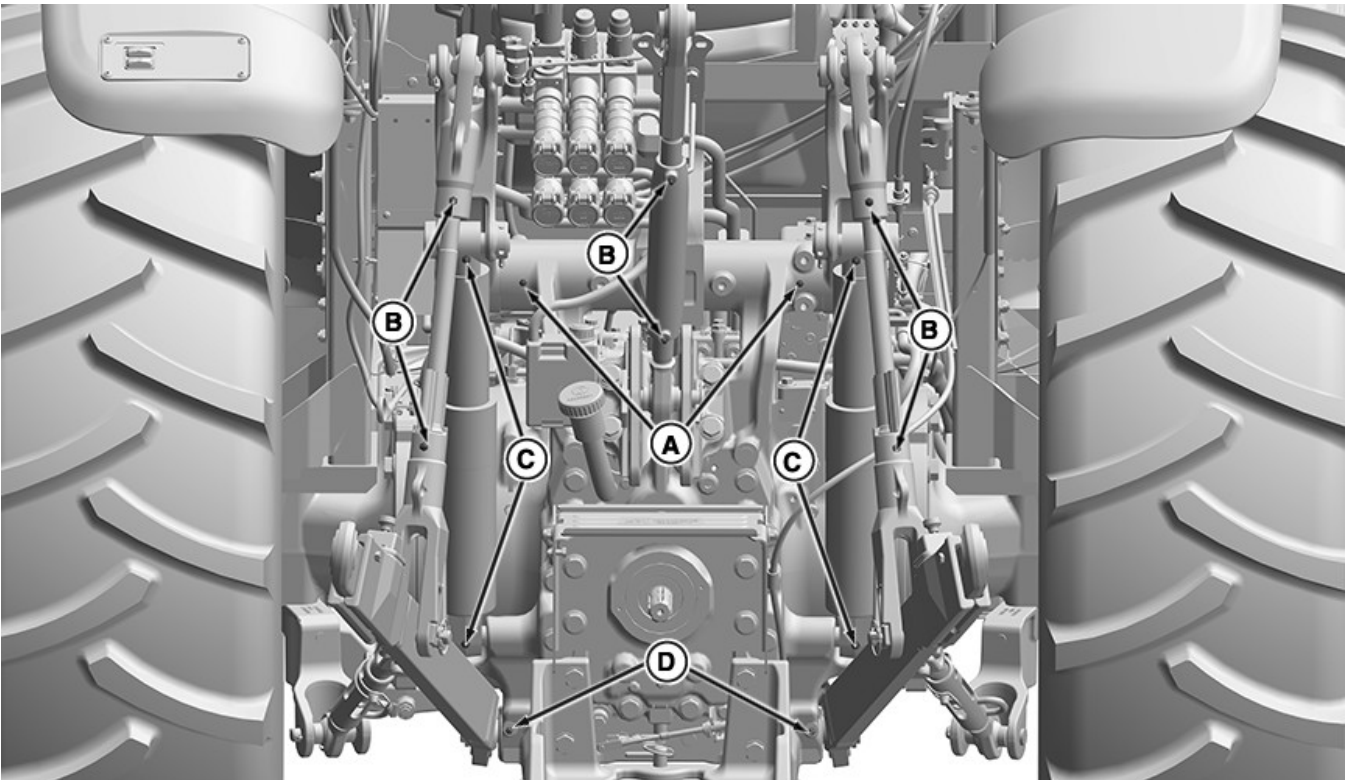

RXA0154404—UN—27FEB17

A—Hitch Bushing Grease Point
B—Hitch Linkage Grease Point

NOTE: Grease daily when operating in wet and muddy conditions.

C—Lift Cylinder Grease Point
D—Draft Sense Shaft Seal

grease points (A—C). See Fuel, Lubricants, and Coolants for correct lubricant.)

GS25068,00015D4-19-19APR21

Apply several shots of general-purpose grease to the

Lubricate Front Hitch

MAINTENANCE INTERVAL

Weekly or Every 50 Hours

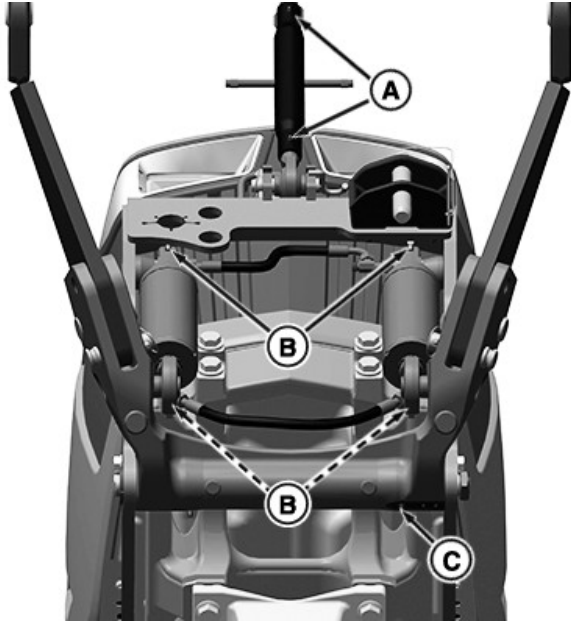

RXA0154215—UN—06OCT16

Viewed From Below Hitch

- A—Hitch Linkage Grease Point
- B—Lift Cylinders Grease Point
- C—Hitch Bushing Grease Point

NOTE: Grease daily when operating in wet and muddy conditions.

Apply several shots of general-purpose grease to the grease points (A—C). (See Fuel, Lubricants, and Coolants for correct lubricant.)

GS25068,00015D5-19-19APR21

Check Hitch and Drawbar for Excessive Wear

MAINTENANCE INTERVAL

Every 250 Hours

Visually inspect the hitch and drawbar for excessive wear, hole deformation, cracks, or damage. Replace parts as needed, see your John Deere dealer.

GS25068,00015D6-19-19APR21

Selective Control Valve Maintenance

Adjust Mechanical SCV Cables

See your John Deere dealer for adjusting mechanical mid and rear SCV cables.

DP51502,0002AFA-19-03FEB17

Empty Rear SCV Oil Collection Bottle

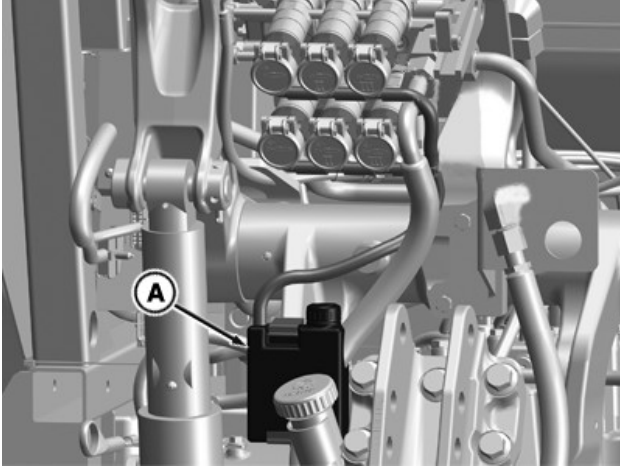

RXA0182236—UN—19APR21

A—Oil Collection Bottle

Check oil collection bottle (A) and empty as required. Dispose of waste properly.

GS25068,00015D7-19-19APR21

Wheels and Tires Maintenance

Inspect Tires

MAINTENANCE INTERVAL

Weekly or Every 50 Hours

IMPORTANT: Keep wheel hardware tight for safety.

1. Check tires daily for damage or noticeably low pressure.
2. Have any cuts or breaks repaired as soon as possible.
3. At least every 50 hours of operation, check tires with an accurate gauge having 10 kPa (0.1 bar) (1 psi) graduations. If tires contain liquid ballast, use a special air-water gauge and measure with the valve stem at bottom.
4. Check wheel hardware torque before operating, twice during first 10 hours of operation and thereafter every week/50 hours of operation.
5. Remove chemicals and petroleum products from tires as soon as possible to avoid damage.

MP60050,0000ABA-19-27APR21

Adjust and Check Clearance

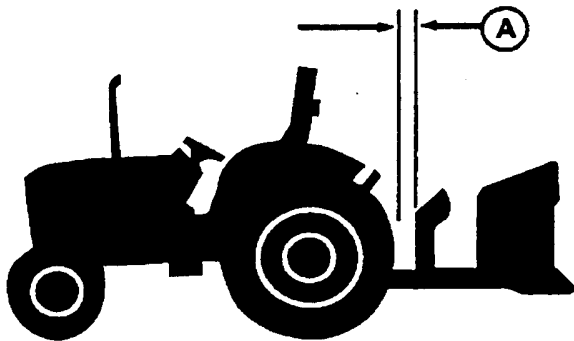

A—Clearance

M47177—UN—31JAN92

IMPORTANT: Whenever an implement, quick coupler, or attachment is connected to the hitch, check full range of operation for interference, binding, or PTO separation.

When large diameter rear tires are installed, a quick coupler or similar device is required to provide adequate implement-to-tire clearance.

1. Adjust center link and lift links as necessary. (See Level Hitch in Hitch and Drawbar Operation section.)
2. Adjust sway as necessary. (See Adjust Hitch Side Sway in Hitch and Drawbar Operation section.)
3. Start engine.

4. Slowly raise and lower implement with hitch fender switch or position lever.
5. Watch for interference points and adjust hitch setting as required.
6. Check for adequate clearance (A) between outside diameter of the tire and implement with hitch in raised position.

GS25068,000544E-19-20SEP18

Check Tire Inflation Pressure

MAINTENANCE INTERVAL

Weekly or Every 50 Hours

Consider the Following When Inflating Tires:

- At least every 50 hours of operation, check inflation pressure with a gauge. Use an accurate gauge having 10 kPa (0.1 bar) (1 psi) graduations. If tires contain liquid ballast, use a special air-water gauge and measure with the valve stem at bottom.
- Correctly inflated radial tires show a large deflection of the sidewall or “cheeks.” Deflection is normal and does not damage the tire if the inflation pressure is maintained.
- Overinflation reduces performance and increases strain of both tire and rim.
- Regularly monitor inflation pressures less than 80 kPa (0.8 bar) (12 psi) because of the increased risk of low pressure leaks (especially due to leaking valve cores).
- When operating machine on a steep side slope or furrow plowing, increase inflation pressures 28 kPa (0.28 bar) (4 psi) above the values listed to compensate for lateral weight transfer.
- Tires run as singles in high-traction conditions sometimes experience bead slip. Increasing the inflation pressure compensates for this condition but causes reduced traction.
- If higher load capacities are needed, contact your John Deere dealer for tire manufacturer load and inflation table information.
- Maximum tire pressure is specified on the tire sidewall.
- Increase front tire pressures 30 kPa (0.3 bar) (4 psi) above values listed when operating with a loader to compensate for weight transfer.

GS25068,00015D9-19-19APR21

Tire Pressures

Long life and satisfactory performance of the tires depend on proper tire inflation. Underinflation of tires

leads to rapid wear. Overinflated tires reduce traction and increase wheel slippage.

Since correct tire pressures vary with working conditions and load, but also with model, tire size and manufacturer, we recommend that you approach your John Deere dealer or tire company for advice.

GS25068,0005450-19-20SEP18

Tire Inflation Pressure Guidelines

Check tire inflation pressure while tires are cool, using an accurate dial or stick-type gauge having 10 kPa (0.1 bar) (1 psi) graduations.

NOTE: Use a special air-water gauge and measure with the valve stem at bottom, if tires contain liquid ballast.

Correctly inflated radial tires show a deflection of the sidewall. This is normal and will not damage the tire.

Inflation pressures less than 83 kPa (0.8 bar) (12 psi) must be monitored frequently because of the increased risk of low-pressure leaks.

NOTE: Bead-slip can be experienced in high-traction conditions when using single tires. Increasing inflation pressure helps, but reduce traction.

Maximum tire pressure is specified on the tire sidewall.

Determining Correct Tire Pressure

Integral implements transfer significant weight to the rear axle. Always include this weight when determining correct inflation pressures. Weigh the machine as described in order to determine the correct tire pressure:

Rear-Mounted Implement - The front axle must be weighed with implement lowered. The rear axle must be weighed with the implement raised.

Front-Mounted Implement - The front axle must be weighed with the implement raised. The rear axle must be weighed with the implement lowered.

Front- and Rear-Mounted Implements - Weigh the machine with front and rear implements both raised.

Set tire inflation pressures according to the weight measured. *Ballasting and tire inflation pressure may need to be adjusted when operating conditions change.* Refer to the tire manufacturers recommended inflation pressures as an initial starting point.

Altering Tire Inflation Pressure

Machines operating with a loader should increase front tire pressures 30 kPa (0.3 bar) (4 psi) above the values listed to compensate for weight transfer.

Machines operating on steep side slopes or furrow plowing should increase rear tire pressures 30 kPa (0.3

bar) (4 psi) above the values listed for base pressures 80 kPa (0.8 bar) (12 psi) and above to compensate for lateral weight transfer. For base pressures below 80 kPa (0.8 bar) (12 psi), pressure should be increased by 30%.

Reduce inflation pressure when using towed implements.

Machines with heavy hitch-mounted implements that require additional front cast weights to maintain steering stability require increased front and rear tire inflation pressure to carry the increased weight.

GS25068,0005451-19-29JUL20

Tire Sidewall Information



RXA0149658—UN—13AUG15

Information useful in selecting and working with tires is displayed on tire sidewalls.

- A**—Tire section width – Width in millimeters.
- B**—Aspect ratio – Ratio of height to tire section width.
- C**—Construction type – R = Radial, B = Bias.
- D**—Rim diameter – Diameter in inches (not total tire height or group size).
- E**—Load index – Numerical code indicates tire load-carrying capacity. Higher load index number designates higher load capacity.
- F**—Speed rating – Maximum speed tire is designed to travel.

Additional information that may be displayed on sidewall:

Tread pattern—Indicates tread design and tire usage. Designs offered are all lug- or bar-type tires and are separated into one of three specifications: R1, R1W, or R2.

Direction of rotation—Icon (usually an arrow or group of arrows) indicating tire rotation direction.

Manufacturer name—Name of tire manufacturer.

Max load and pressure information—Maximum load a tire is permitted to carry under specified

pressure and operating conditions.

Safety warnings—Important information provided by tire manufacturer.

GS25068,0005453-19-20SEP18

Use Correct Tire Combinations

IMPORTANT: When replacing tires, consult your tire or John Deere dealer. Mixing worn and new tires, bias and radial, or tires of different diameters or loaded radii can reduce tire life and overall machine performance.

Using tire combinations not listed in the Tire Compatibility Chart could result in premature tire and driveline wear due to excessive underspeed or overspeed.

In order to achieve maximum drawbar pull, maintain proper steerability, and reduce tire wear and fuel consumption, comply with the correct tire combinations.

When MFWD front tires show excessive wear in comparison with the rear tires, the front tires must be replaced in order to maintain the predetermined tire ratio.

Front	Rear
11.2-24	16.9-30
12.5/80-18	19.5L-24
12.4R24 (320/85R24)	18.4R30 (460/85R30)
340/85R24	400/75R38
380/85R24	460/85R34
14.9R24 (380/85R24)	16.9R38 (420/85R38)
230/95R32	230/95R48
380/70R24	480/70R34
400/80R24	480/80R34
480/65R24	540/65R38

Tire Combinations

MP60050,0000ABB-19-26JUL21

Correct Tire Selection

IMPORTANT: When replacing tires, consult your tire dealer. Mixing worn and new tires, bias and radial, or tires of different diameters or loaded radii can reduce tire life and overall tractor performance.

Using any tire combination, other than those listed on the Tire Compatibility Chart, could result in premature tire and driveline wear due to excessive underspeed or overspeed.

IMPORTANT: If a different tire combination is selected, or new rear tires are selected with an SRI (speed/radius index) higher than the previous one, the tractors electronics must be recalibrated by your John Deere dealer.

IMPORTANT: To prevent damage to the drivetrain and avoid premature tire wear, obtain a front axle overspeed calculation between 100—105%. This correlates to a 0—5% MFWD axle overspeed, which is recommended for optimal performance.

The size ratio of the front wheels to the rear ones is precisely determined in order to produce a positive front wheel lead of between 0% and 5%. To ascertain the correct ratio when changing tires, proceed as follows:

NOTE: There are three different methods for calculating MFWD axle overspeed.

Calculate MFWD Axle Overspeed with Front/Rear Axle Ratio:

Determine Front/Rear Axle Ratio



RXA0139133—UN—05FEB14

Locate front/rear axle ratio displayed on a label located below the rear window on the right-hand side inside of the cab. The following ratios are possible:

- 1.347
- 1.392

Determine Tire Rolling Circumferences

This information must be obtained from the tire manufacturers manual.

1. Select tires with suitable load-bearing capability.
2. Select tires appropriate to the tractors top speed.
3. From the manual, obtain the rolling circumference of the tire desired for the rear wheel.
4. From the manual, obtain the rolling circumference of the tire desired for the front wheel.

MFWD Axle Overspeed Formula

Calculate the overall transmission ratio using the following formula:

$$\text{MFWD Axle Overspeed} = \frac{\text{Rolling Circumference of Front Tire}}{\text{Rolling Circumference of Rear Tire}} (\times \text{F/R Axle Ratio}) \times 100\%$$

MFWD Axle Overspeed Formula (F/R Axle Ratio)

Using the above formula, the following is an example of the calculation:

- Rolling circumference of the front tire = 3420 mm (134.6 in)
- Rolling circumference of the rear tire = 4395 mm (173.0 in)
- Front to rear axle ratio = 1.347

$$\text{MFWD Axle Overspeed} = \frac{3420}{4395} (\times 1.347) \times 100\%$$

MFWD Axle Overspeed Example

In the example, the MFWD axle overspeed equates to 104.8% or a 4.8% overspeed. The tires would be acceptable to use.

Calculate MFWD Axle Overspeed Alternate Method:

1. Mark the front/rear tires and the ground where they contact.
2. **With the MFWD Off**, roll the machine ten revolutions of the rear tires and count the revolutions of the front tire.
3. **With the MFWD On**, roll the machine ten revolutions of the rear tires and count the revolutions of the front tire.
4. Calculate the difference percentage.

$$\text{MFWD Axle Overspeed} = \frac{[(\text{MFWD On Revolutions} - \text{MFWD Off Revolutions}) / \text{MFWD Off Revolutions}] \times 100}{1}$$

MFWD Axle Overspeed Formula (Alternate Method)

GS25068,0001ACA-19-24JAN22

Changing Tire Sizes

NOTE: When changing tire sizes, it is recommended to have your John Deere dealer ensure that the machine is properly set up.

- Changing tire sizes requires a software change to

ensure that correct ground speed is achieved and displayed.

- Any change of tire combination must conform to a combination authorized for that particular machine.
- Depending on the new tire size, a change to the MFWD ratio may be required.

DP51502,0002DC6-19-14SEP17

Select Front Tire Rolling Direction

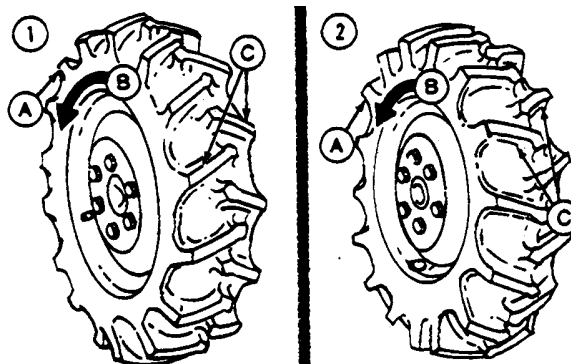

RW510—UN—06APR89

Left Tire (Viewed From Rear)

- A—Front Tire (Viewed from Rear)
- B—Rolling Direction of Tire
- C—Tire Lugs

1. Under most conditions, front tires (A) are mounted with the direction of tire lugs (C) the same as the tire rolling direction (B).
2. If machine is used primarily for loader operations, lug direction can be reversed on the MFWD axle for improved tire wear.

GS25068,0003F48-19-08FEB18

Dual Wheel Usage

IMPORTANT: Do not use dual wheels on this machine. Machine damage occurs if dual wheels are installed and used on either the front or rear axle.

GS25068,00015DA-19-19APR21

Rear Wheel Tread Width Limitations

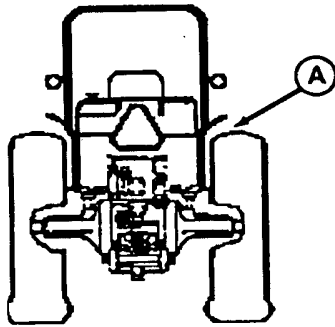

M47179—UN—31JAN92

A—Rear Wheel-to-Fender Clearance

IMPORTANT: Tires must have at least 25 mm (1 in) clearance with fenders (A). When rear tires are installed, check clearance between the tire and fenders.

DP51502,0002B06-19-03FEB17

- Adjust wheel tread by exchanging the wheels from side-to-side and by using spacers.
- Tread settings are measured at the middle of the tires at axle height.

Set Tread—Two-Position MFWD Wheels

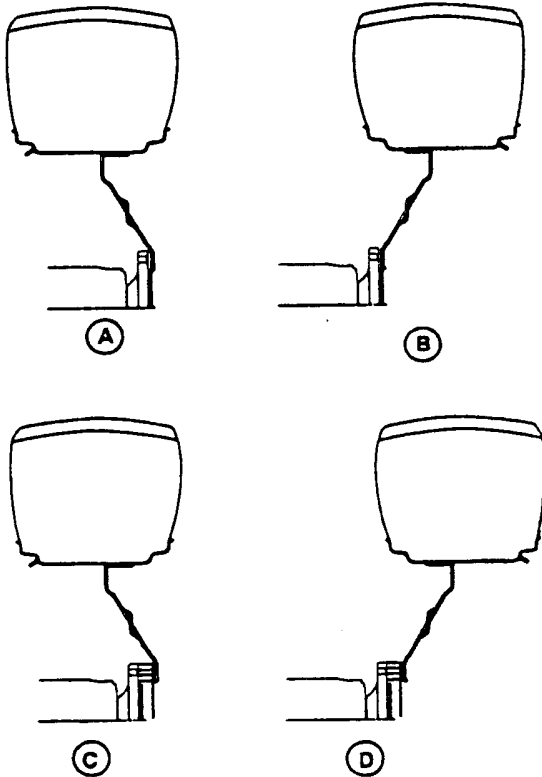

M47178—UN—31JAN92

Two-Position MFWD Wheels—Tread Width (Centerline-to-Centerline)				
Tire	No Spacer		60 mm Spacer	
	A	B	C	D
12.5/80-18	1578 mm (62.1 in)	1724 mm (67.9 in)	1698 mm (66.85 in)	1844 mm (72.59 in)

MP60050,0000ABC-19-27APR21

Set Tread—Multi-Position MFWD Wheels

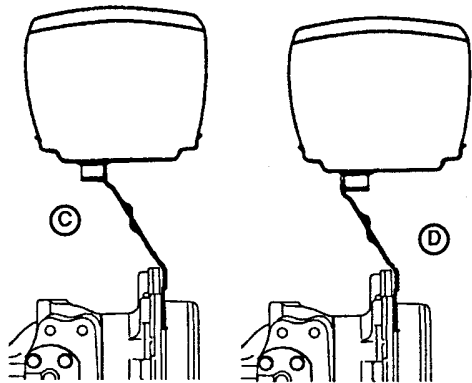
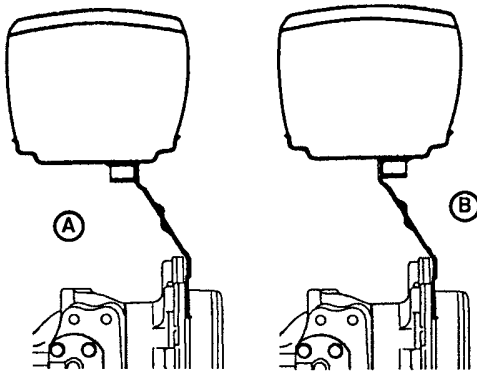

LV601—UN—22APR94

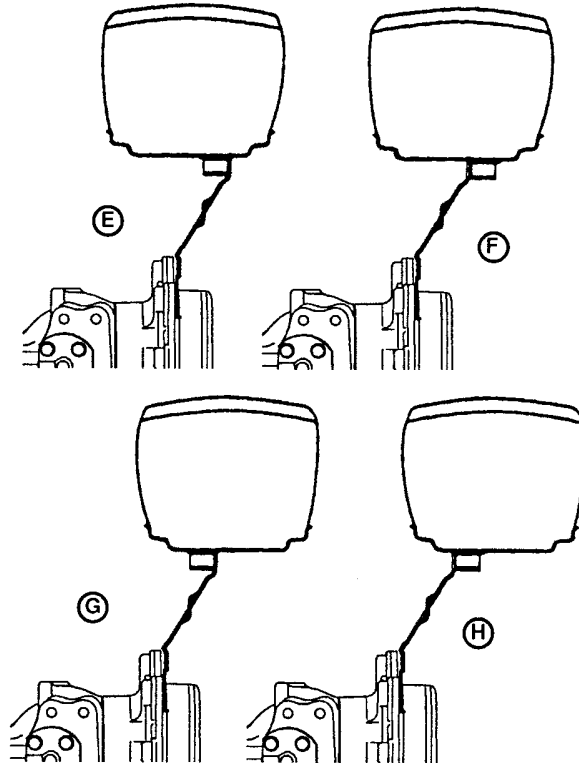

LV602—UN—22APR94

- Wheel tread with multi-position wheels is adjusted by repositioning or exchanging the rims or by reversing the wheel disks.
- Wheel tread can also be adjusted by exchanging the complete wheel to the opposite side of the machine. This permits the change from disk-dished-in to disk-dished-out operations without disassembling the wheel.
- When changing wheels from one side to the other, the arrow on the sidewall of tire points in the direction of forward rotation.
- The wheel tread can be adjusted by exchanging the wheels from side-to-side and by using spacers.
- Tread settings are measured at the middle of the tires at axle height.

Wheels and Tires Maintenance

Multi-Position MFWD Wheels—Tread Width (Centerline-to-Centerline)								
No Spacer								
Tire	A	B	C	D	E	F	G	H
11.2R24 (280/85R24)	1300 mm (51.1 in)	1398 mm (55.0 in)	1500 mm (59.0 in)	1596 mm (62.8 in)	1700 mm (66.9 in)	1798 mm (70.7 in)	1900 mm (74.8 in)	1998 mm (78.6 in)
12.4R24 (320/85R24)	Interference	1398 mm (55.0 in)	1500 mm (59.0 in)	1596 mm (62.8 in)	1700 mm (66.6 in)	1798 mm (70.7 in)	1900 mm (74.8 in)	1998 mm (78.6 in)
13.6R24 (340/85R24)	Interference	1396 mm (54.9 in)	1500 mm (59.0 in)	1596 mm (62.8 in)	1700 mm (66.9 in)	1796 mm (70.7 in)	1900 mm (74.8 in)	1996 mm (77.5 in)
14.9R24 (380/85R24)	Interference	1396 mm (54.9 in)	1504 mm (59.2 in)	1600 mm (62.9 in)	1700 mm ^a (66.9 in)	1796 mm (70.7 in)	1904 mm (74.9 in)	2000 mm (78.7 in)
230/95R32	1300 mm (51.2 in)	1400 mm (55.1 in)	1504 mm (59.2 in)	1602 mm (63.1 in)	1702 mm (67.0 in)	1800 mm (70.9 in)	1904 mm (75.0 in)	2004 mm (78.9 in)
380/70R24	Interference	1396 mm (54.9 in)	1500 mm (59.0 in)	1596 mm (62.8 in)	1700 mm (66.9 in)	1796 mm (70.7 in)	1900 mm (74.8 in)	1996 mm (78.5 in)
400/80R24	Interference	1396 mm (54.9 in)	1500 mm (59.0 in)	1596 mm (62.8 in)	1700 mm (66.9 in)	1796 mm (70.7 in)	1900 mm (74.8 in)	1996 mm (78.5 in)
480/65R24	Interference	Interference	1504 mm (59.2 in)	1600 mm (62.9 in)	1700 mm ^b (66.9 in)	1796 mm ^c (70.7 in)	1904 mm (74.9 in)	2000 mm (78.7 in)

^aFender Adjustment Required

^bFender Adjustment Required, but Rubs Fuel Tank

^cTire Contacts Fender Bolt at Full Turn

Multi-Position MFWD Wheels—Tread Width (Centerline-to-Centerline)								
60 mm Spacer								
Tire	A	B	C	D	E	F	G	H
11.2R24 (280/85R24)	1420 mm (55.90 in)	1518 mm (59.76 in)	1620 mm (63.77 in)	1716 mm (67.55 in)	1820 mm (71.65 in)	1918 mm (75.51 in)	2020 mm (79.52 in)	2118 mm (83.38 in)
12.4R24 (320/85R24)	1420 mm (55.90 in)	1518 mm (59.76 in)	1620 mm (63.77 in)	1716 mm (67.55 in)	1820 mm (71.65 in)	1918 mm (75.51 in)	2020 mm (79.52 in)	2118 mm (83.38 in)
13.6R24 (340/85R24)	1420 mm (55.90 in)	1516 mm (59.68 in)	1620 mm (63.77 in)	1716 mm (67.55 in)	1820 mm (71.65 in)	1916 mm (75.43 in)	2020 mm (79.52 in)	2116 mm (83.30 in)
14.9R24 (380/85R24)	1420 mm (55.90 in)	1516 mm (59.68 in)	1624 mm (63.93 in)	1720 mm (67.71 in)	1820 mm (71.65 in)	1916 mm (75.43 in)	2024 mm (79.68 in)	2120 mm (83.46 in)
230/95R32	1420 mm (55.90 in)	1516 mm (59.68 in)	1624 mm (63.93 in)	1720 mm (67.71 in)	1822 mm (71.73 in)	1920 mm (75.59 in)	2024 mm (79.68 in)	2124 mm (83.62 in)
380/70R24	1405 mm (55.31 in)	1516 mm (59.68 in)	1620 mm (63.77 in)	1720 mm (67.71 in)	1820 mm (71.65 in)	1916 mm (75.43 in)	2020 mm (79.52 in)	2116 mm (83.30 in)
400/80R24	1405 mm (55.31 in)	1516 mm (59.68 in)	1620 mm (63.77 in)	1720 mm (67.71 in)	1820 mm (71.65 in)	1916 mm (75.43 in)	2020 mm (79.52 in)	2116 mm (83.30 in)
480/65R24	1420 mm (55.90 in)	1516 mm (59.68 in)	1624 mm (63.93 in)	1720 mm (67.71 in)	1820 mm (71.65 in)	1916 mm (75.43 in)	2024 mm (79.68 in)	2120 mm (83.46 in)

MP60050,0000ABD-19-27APR21

Set Tread—Multi-Position Rear Wheels

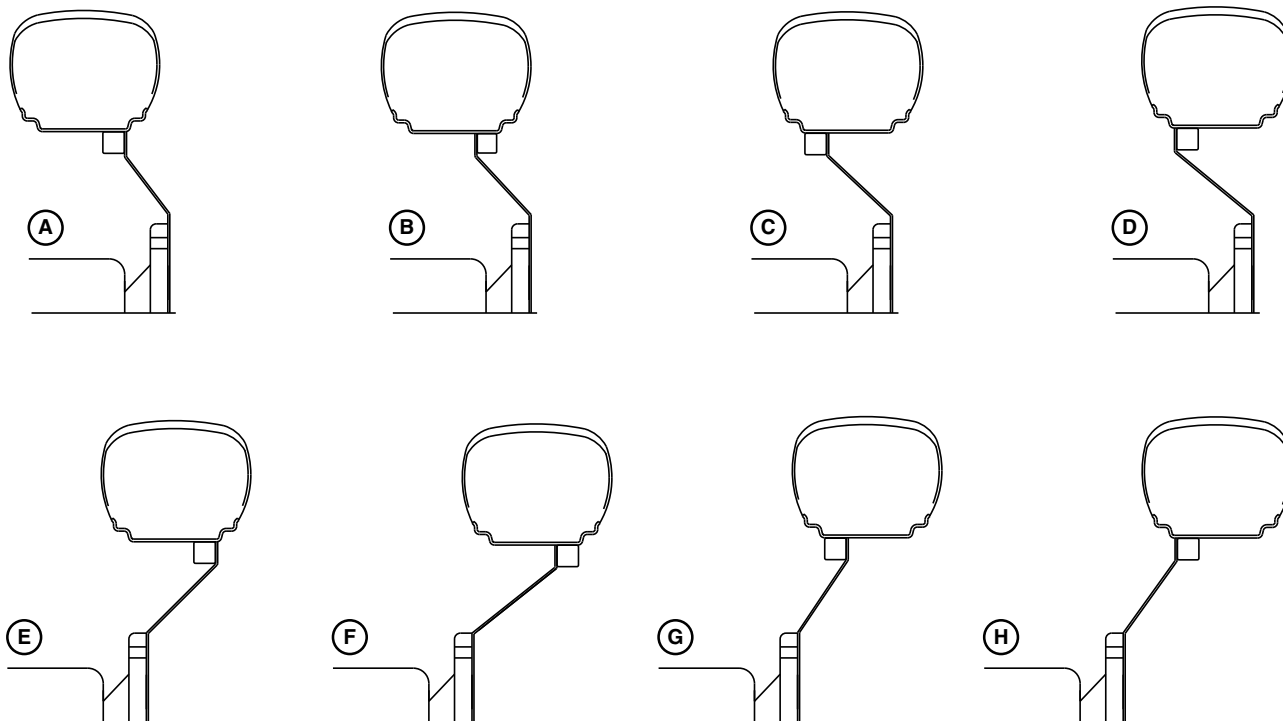

LV8610—UN—28AUG03

- Wheel tread with multi-position wheels is adjusted by repositioning or exchanging the rims or by reversing the wheel disks.
- Wheel tread can also be adjusted by exchanging the complete wheel to the opposite side of the machine. This permits the change from disk-dished-in to disk-dished-out operations without disassembling the wheel.
- When changing wheels from one side to the other, the arrow on the sidewall of tire points in the direction of forward rotation.
- The wheel tread can be adjusted by exchanging the wheels from side-to-side and by using spacers.
- Tread settings are measured at the middle of the tires at axle height.

Multi-Position Rear Wheels—Tread Width (Centerline-to-Centerline)								
No Spacer								
Tire	A	B	C	D	E	F	G	H
400/75R38	Interference	Interference	Interference	Interference	1491 mm (58.7 in)	1595 mm (62.7 in)	1691 mm (66.5 in)	1795 mm (70.6 in)
16.9R30 (420/85R30)	Interference	Interference	Interference	Interference	1497 mm (58.9 in)	1591 mm (62.6 in)	1701 mm (66.9 in)	1795 mm (70.6 in)
16.9R38 (420/85R38)	Interference	Interference	Interference	Interference	1491 mm (58.7 in)	1591 mm (62.6 in)	1695 mm (66.9 in)	1795 mm (70.6 in)
18.4R30 (460/85R30)	Interference	Interference	Interference	Interference	1497 mm (58.9 in)	1591 mm (62.6 in)	1701 mm (66.9 in)	1795 mm (70.6 in)
18.4R34 (460/85R34)	Interference	Interference	Interference	Interference	1495 mm (58.8 in)	1595 mm (62.7 in)	1695 mm (66.7 in)	1795 mm (70.6 in)
19.5L-24	Interference	Interference	Interference	Interference	Interference	1587 mm (62.4 in)	1707 mm (67.2 in)	1803 mm (70.9 in)
230/95R48	Interference	Interference	1295 mm (50.9 in)	1395 mm (54.9 in)	1491 mm (58.7 in)	1591 mm (62.6 in)	1695 mm (67.7 in)	1795 mm (70.6 in)
480/70R34	Interference	Interference	Interference	Interference	Interference	1595 mm (62.7 in)	1695 mm (67.7 in)	1795 mm (70.6 in)
480/80R34	Interference	Interference	Interference	Interference	Interference	1595 mm (62.7 in)	1695 mm (66.7 in)	1795 mm (70.6 in)

Wheels and Tires Maintenance

Multi-Position Rear Wheels—Tread Width (Centerline-to-Centerline)								
No Spacer								
Tire	A	B	C	D	E	F	G	H
540/65R38	Interference	Interference	Interference	Interference	Interference	1591 mm (62.6 in)	1695 mm (66.9 in)	1795 mm (70.6 in)

Multi-Position Rear Wheels—Tread Width (Centerline-to-Centerline)								
30 mm Spacer								
Tire	A	B	C	D	E	F	G	H
400/75R38	Interference	Interference	Interference	1479 mm (58.2 in)	1575 mm (62 in)	1679 mm (66.1 in)	1775 mm (69.9 in)	1879 mm (74 in)
16.9R30 (420/85R30)	Interference	Interference	Interference	1473 mm (58 in)	1575 mm (62 in)	1669 mm (65.7 in)	1779 mm (70 in)	1873 mm (73.7 in)
16.9R38 (420/85R38)	Interference	Interference	Interference	1479 mm (58.2 in)	1575 mm (62 in)	1675 mm (65.9 in)	1779 mm (70 in)	1879 mm (74 in)
18.4R30 (460/85R30)	Interference	Interference	Interference	Interference	1575 mm (62 in)	1669 mm (65.7 in)	1779 mm (70 in)	1873 mm (73.7 in)
18.4R34 (460/85R34)	Interference	Interference	Interference	Interference	1575 mm (62 in)	1675 mm (65.9 in)	1775 mm (69.9 in)	1875 mm (73.8 in)
19.5L-24	Interference	Interference	Interference	Interference	1567 mm (61.7 in)	1663 mm (65.5 in)	1783 mm (70.2 in)	1879 mm (74 in)
230/95R48	Interference	1275 mm (50.2 in)	1455 mm (57.3 in)	1455 mm (57.3 in)	1575 mm (62 in)	1455 mm (57.3 in)	1455 mm (57.3 in)	1879 mm (74 in)
480/70R34	Interference	Interference	Interference	Interference	1575 mm (62 in)	1675 mm (65.9 in)	1775 mm (69.9 in)	1875 mm (73.8 in)
480/80R34	Interference	Interference	Interference	Interference	1575 mm (62 in)	1675 mm (65.9 in)	1775 mm (69.9 in)	1875 mm (73.8 in)
540/65R38	Interference	Interference	Interference	Interference	Interference	1671 mm (65.8 in)	1775 mm (69.9 in)	1875 mm (73.8 in)

Multi-Position Rear Wheels—Tread Width (Centerline-to-Centerline)								
44 mm Spacer								
Tire	A	B	C	D	E	F	G	H
400/75R38	Interference	Interference	Interference	1507 mm (59.3 in)	1603 mm (63.1 in)	1707 mm (67.2 in)	1803 mm (71 in)	1907 mm (75.1 in)
16.9R30 (420/85R30)	Interference	Interference	Interference	1501 mm (59.1 in)	1603 mm (63.1 in)	1697 mm (66.8 in)	1807 mm (71.1 in)	1901 mm (74.8 in)
16.9R38 (420/85R38)	Interference	Interference	Interference	1507 mm (59.3 in)	1603 mm (63.1 in)	1703 mm (67 in)	1807 mm (71.1 in)	1907 mm (75.1 in)
18.4R30 (460/85R30)	Interference	Interference	Interference	Interference	1603 mm (63.1 in)	1697 mm (66.8 in)	1807 mm (71.1 in)	1901 mm (74.8 in)
18.4R34 (460/85R34)	Interference	Interference	Interference	Interference	1603 mm (63.1 in)	1703 mm (67 in)	1803 mm (71 in)	1903 mm (75.1 in)
19.5L-24	Interference	Interference	Interference	Interference	1595 mm (62.8 in)	1691 mm (66.6 in)	1811 mm (71.3 in)	1907 mm (75.1 in)
230/95R48	Interference	1303 mm (51.3 in)	1407 mm (55.4 in)	1507 mm (59.3 in)	1603 mm (63.1 in)	1703 mm (67 in)	1807 mm (71.1 in)	1907 mm (75.1 in)
480/70R34	Interference	Interference	Interference	Interference	1603 mm (63.1 in)	1703 mm (67 in)	1803 mm (71 in)	1903 mm (75.1 in)
480/80R34	Interference	Interference	Interference	Interference	1603 mm (63.1 in)	1703 mm (67 in)	1803 mm (71 in)	1903 mm (75.1 in)
540/65R38	Interference	Interference	Interference	Interference	1603 mm (63.1 in)	1703 mm (67 in)	1803 mm (71 in)	1903 mm (75.1 in)

Wheels and Tires Maintenance

Multi-Position Rear Wheels—Tread Width (Centerline-to-Centerline)								
111 mm Spacer								
Tire	A	B	C	D	E	F	G	H
400/75R38	Interference	1441 mm (56.7 in)	1537 mm (60.5 in)	1641 mm (64.6 in)	1737 mm (68.4 in)	1841 mm (72.5 in)	1937 mm (76.3 in)	2041 mm (85.4 in)
16.9R30 (420/85R30)	Interference	Interference	1541 mm (60.7 in)	1635 mm (64.4 in)	1737 mm (68.4 in)	1831 mm (72.1 in)	1941 mm (76.4 in)	2035 mm (80.1 in)
16.9R38 (420/85R38)	Interference	Interference	1541 mm (60.7 in)	1641 mm (64.6 in)	1737 mm (68.4 in)	1837 mm (72.3 in)	1941 mm (76.4 in)	2041 mm (85.4 in)
18.4R30 (460/85R30)	Interference	Interference	1541 mm (60.7 in)	1635 mm (64.4 in)	1737 mm (68.4 in)	1831 mm (72.1 in)	1941 mm (76.4 in)	2035 mm (80.1 in)
18.4R34 (460/85R34)	Interference	Interference	1537 mm (60.5 in)	1637 mm (64.5 in)	1737 mm (68.4 in)	1837 mm (72.3 in)	1937 mm (76.3 in)	2037 mm (80.2 in)
19.5L-24	Interference	Interference	1545 mm (60.8 in)	1641 mm (64.6 in)	1729 mm (68.1 in)	1825 mm (71.9 in)	1945 mm (76.6 in)	2041 mm (85.4 in)
230/95R48	1337 mm (52.6 in)	1437 mm (56.6 in)	1541 mm (60.7 in)	1641 mm (64.6 in)	1737 mm (68.4 in)	1837 mm (72.3 in)	1941 mm (76.4 in)	2041 mm (85.4 in)
480/70R34	Interference	Interference	1537 mm (60.5 in)	1637 mm (64.5 in)	1737 mm (68.4 in)	1837 mm (72.3 in)	1937 mm (76.3 in)	2037 mm (80.2 in)
480/80R34	Interference	Interference	1537 mm (60.5 in)	1637 mm (64.5 in)	1737 mm (68.4 in)	1837 mm (72.3 in)	1937 mm (76.3 in)	2037 mm (80.2 in)
540/65R38	Interference	Interference	Interference	1641 mm (64.6 in)	1737 mm (68.4 in)	1837 mm (72.3 in)	1941 mm (76.4 in)	2041 mm (85.4 in)

MP60050,0000ABF-19-26JUL21

Tighten Wheel Bolts Correctly

CAUTION: NEVER operate machine with a loose rim, wheel, hub, or axle.

NOTE: Follow checking procedure when a new machine is first used or wheels have been off.

Any time hardware is loosened, tighten to specified torque. (See Tighten Wheel Bolts for the specific axle on the machine in this section.)

1. After driving machine about 100 m (109 yd) and before placing it under load, tighten hardware to specified torque.
2. Check hardware after working 3 hours and again after 10 hours.
3. Check all hardware frequently every 50 hours thereafter.

GS25068,0005459-19-20SEP18

Install Wheel Spacer

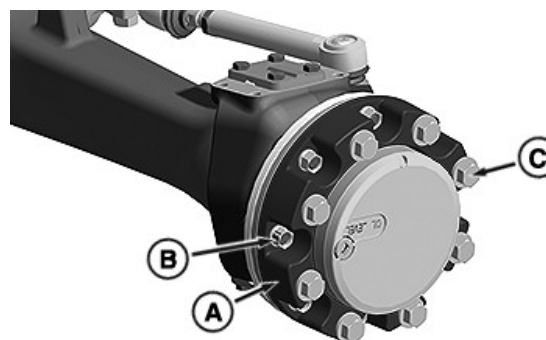

RXA0154078—UN—17NOV16

- A—Spacer
- B—Flange Nut (8)
- C—Cap Screw (8)

NOTE: Front and rear wheel spacers are available. See your John Deere dealer.

Any time hardware is loosened, tighten to specified torque.

1. Install the spacer (A) over the hub.
2. Lubricate and install flange nuts (B).
3. Tighten to specified torque.

Specification

Front Axle Flange Nut—Torque. 320 N·m
(236 lb-ft)

Specification

Rear Axle Flange Nut—Torque. 510 N·m
(376 lb·ft)

4. Install wheel and tighten cap screws (C) to specified torque. (See Tighten Wheel Bolts for the specific axle on the machine in this section.)

GS25068,00015DB-19-30MAR22

Tighten Wheel Bolts—MFWD Axle



LV14727—UN—25AUG11

- A—MFWD Wheel Rim-to-Disk Bolt (8)
- B—MFWD Wheel Disk-to-Hub Nut (8)

1. Tighten MFWD wheel rim-to-disk bolts (A) to specification.

Specification

MFWD Wheel Rim-to-Disk Bolts
(A)—Torque. 245 N·m
(180 lb·ft)

2. Tighten MFWD wheel disk-to-hub nuts (B) to specification.

Specification

MFWD Wheel Disk-to-Hub Nuts
(B)—Torque. 320 ± 30 N·m
(236 ± 22 lb·ft)

3. Drive machine 100 m (109 yd) and tighten again.

GS25068,00015DC-19-21APR21

Tighten Wheel Bolts—Rear Axle



LV14279—UN—10MAY11

- A—Rear Wheel Rim-to-Disk Bolt (8)
- B—Rear Wheel Disk-to-Hub Nut (8)

1. Tighten wheel rim-to-disk bolts (A) to specification.

Specification

Rear Wheel Rim-to-Disk Bolts
(A)—Torque. 245 N·m
(180 lb·ft)

2. Tighten wheel disk-to-hub nuts (B) to specification.

Specification

Rear Steel Wheel Disk-to-Hub
Nuts (B)—Torque. 510 ± 50 N·m
(376 ± 36 lb·ft)

3. Drive machine 100 m (109 yd) and tighten again.

GS25068,00015DD-19-21APR21

Jacking Up Machine

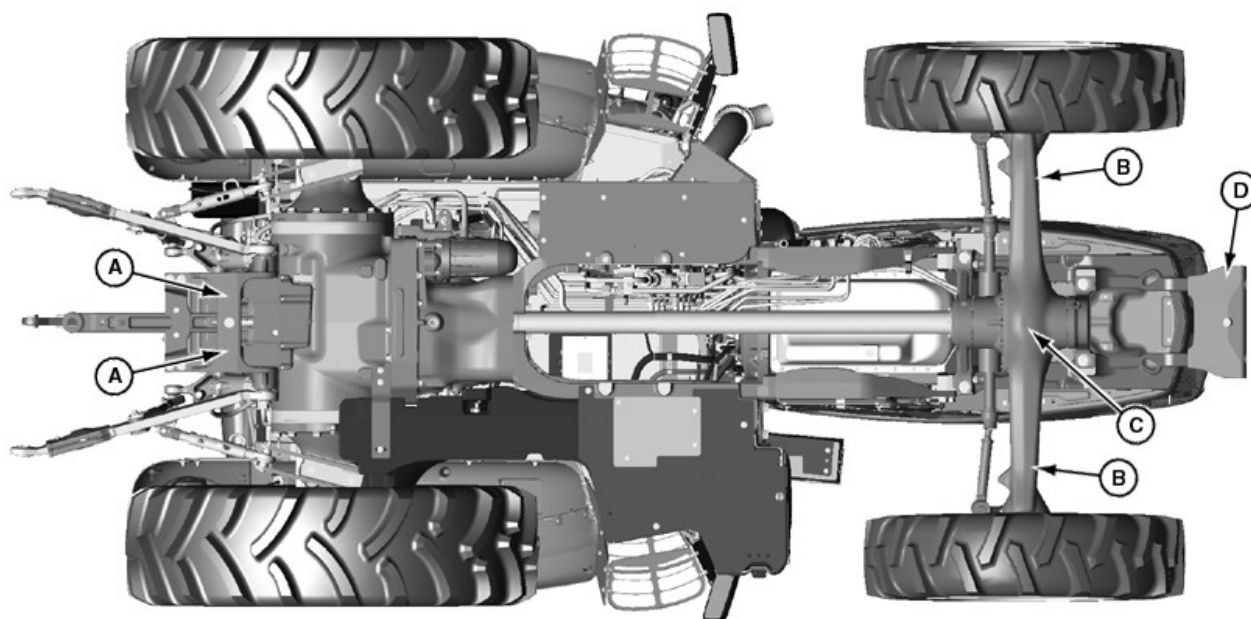

A—Rear of Machine Lift Point
B—Front of Machine Lift Point

CAUTION: Use approved lifting equipment only. Jack up the machine on firm, level ground only.

Before doing any work on the machine, first secure it using suitable jackstands.

NOTE: It is recommended to remove front ballast weights before lifting front end of machine.

The illustration shows the recommended lifting points for jacking up the machine. Use a stable jack with sufficient lifting force. (See Specification section.)

LV22152—UN—18JUN14

C—Center of Axle Lift Point (use wooden wedges to prevent axle from tilting)
D—Front End of Machine under the Basic Weight



LX1049890

LX1049890—UN—11FEB11
GS25068,000545D-19-20SEP18

Check Toe-In—MFWD Axle

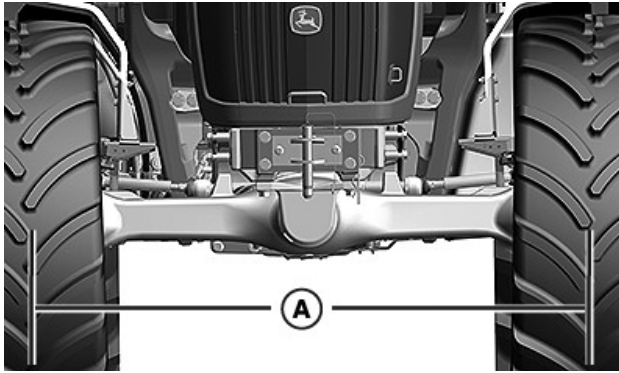

RXA0153367—UN—10AUG16

A—MFWD Axle Toe-In Distance

1. Disengage MFWD and park machine on smooth, level surface. Steer front wheels straight ahead. Stop engine.
2. Measure MFWD axle toe-in distance (A) between centerline of tires at hub level in front of axle, using an outside lug of each tire or an inside lug of each tire. Record measurement and mark the tires.
3. Move machine back about 1 m (3 ft), so mark is at the hub level behind the axle. Again, measure distance between tires at same point on tire. Record measurement.
4. Determine the difference between front and rear measurements. If the front measurement is smaller, toe is in. If the rear is smaller, toe is out. The difference may be in either direction (toe-in or toe-out), but must be less than 3 mm (1/8 in). Adjust toe-in if necessary. (See Adjust Toe-In—MFWD Axle in this section.)

GS25068,0005460-19-20SEP18

Adjust Toe-In—MFWD Axle

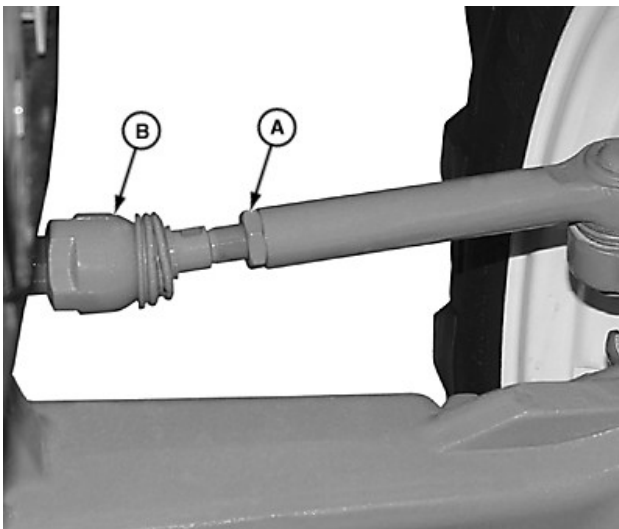

LV14732—UN—25AUG11

A—Tie Rod Jam Nuts

B—Inner Rod

1. Loosen tie rod lock nuts (A) on both ends of tie rod.
2. Adjust both sides equally by rotating the inner rod (B) to lengthen or shorten the tie rod to obtain toe-in or toe-out of less than 3 mm (1/8 in).

Tie Rod Rotation	Approximate Change
1/8 turn	4 mm (3/16 in)
1/4 turn	8 mm (3/8 in)
1/2 turn	16 mm (5/8 in)

3. Tighten lock nuts to specification.

Specification

Tie Rod Lock Nut—Torque: 220—240 N·m
(162—177 lb·ft)

GS25068,0005461-19-20SEP18

Set Steering Stops

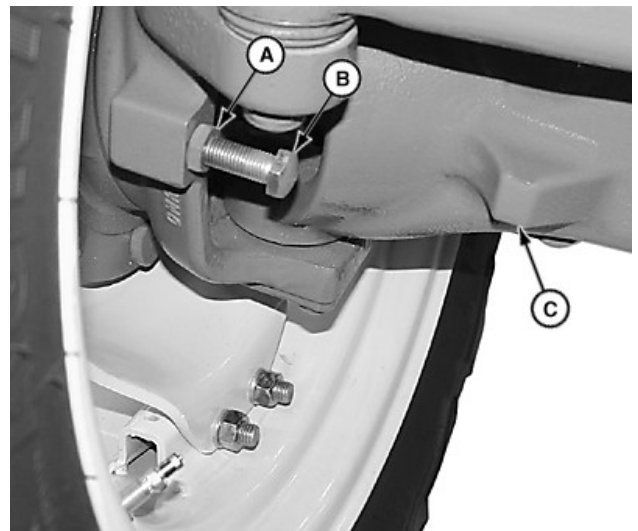

LV14733—UN—25AUG11

- A—Steering Stop Lock Nut
- B—Steering Stop Bolt
- C—Steering Stop

NOTE: Wide tread settings and large tire sizes increase turn radius slightly.

1. Raise and support front of the machine so the MFWD axle can be oscillated to its stops.
2. Slowly turn steering wheel to the left until steering cylinder travel has reached its limit, the steering stops, or the tires are within 25 mm (1 in) of grille screen or side panels.
3. Raise left side of the axle against its stop and measure clearance between tire and nearest machine component. The distance must not be less than 25 mm (1 in).

4. Loosen lock nut (A) on steering stop and adjust steering stop bolt (B) so it touches steering stop (C). Shorten the stop bolt (B) in order to obtain maximum turning angle if necessary.
5. Tighten steering stop bolt retaining lock nut (A) to specifications.

Specification

Steering Stop Bolt Retaining
Lock Nut—Torque. 125 N·m
(92 lb·ft)

6. Turn wheel fully to the left. Impact knuckle housing to steering stop five times.
7. Tighten steering stop bolt retaining nuts again to specification.
8. Repeat steps for the right side.

GS25068,0003F4D-19-08FEB18

Ballasting Maintenance

General Ballast Information

CAUTION: Do not exceed permissible axle load or tire carrying capacities when adding ballast to the machine.

IMPORTANT: As front weight and tread width increase, steering capacity of machine is reduced.

Basic Ballasting Definitions

Ballast is mass added to machine chassis and/or wheels to:

- Increase total weight and/or
- The influence of weight distribution between the front axle and rear axle (static balance). Static means that front and rear axle loads are determined when machine is parked.

Weight split is the static weight distribution between front and rear axles. It is expressed as percentages of total machine static weight supported by front and rear axles. For example, if the front axle supports 40% of total static machine weight, machine has a 40/60 weight split. Percentage of front axle weight is always stated first in this form.

A properly ballasted machine for a given type of implement (towed, integral, or semi-integral) has both correct total weight and static balance for that implement type.

Major Considerations

Required ballast amount and mounting location depend on type of implement being used and operating speed.

Ballasting is required to:

- Assure front axle carries sufficient weight for steering security and stability with a field draft load, as well as transport in field and on road.
- Provide sufficient traction to pull high draft loads efficiently.
- Provide proper fore/aft balance to minimize occurrence of power hop in MFWD machines.
- Assure rear axle carries sufficient weight for traction, braking, and stability when a loader or other front implement is attached to front of machine.

Reconfigure ballast on machine when changing from one implement or attachment to another.

MFWD:

Implement Type	Rear % of Machine Weight	Front % of Machine Weight
Towed	65	35
Semi-Integral	60	40

Implement Type	Rear % of Machine Weight	Front % of Machine Weight
Integral	60 ^a	40

^aFront weight requirements are determined by weight of hitch-mounted implements. Add enough front weights to maintain steering control.

GS25068,00015DE-19-19APR21

Select Ballast Carefully

CAUTION: When determining axle ballast, ensure permissible axle loads and the permissible weight are not exceeded. (See Specifications section.)

Comply with local regulations regarding installation and maximum permissible number of weights. To maintain steering capability, at least 20% of total weight must be on the front axle.

CAUTION: Use suitable lifting tools when handling weights.

Safety and performance of your machine depend on ballasting of the front axle (front weights) and rear axle (wheel weights, filling tires with liquid ballast).

Match amount of ballast needed for each job. Changing implements or attaching a loader requires changing ballast for best performance.

Factors determining amount of ballast:

- Soil surface—loose or firm
- Type of implement—integral/semi-integral or towed
- Travel speed—slow or fast
- Machine power output—partial or full load
- Tire size

Ballasting MFWD Machines

Ideal tire slippage for MFWD is 8—12%. To reduce wheel slip, more weight is needed on the front. The ideal weight is 40% front and 60% rear of total machine weight. In some cases, liquid ballast is needed in tires to obtain this weight split.

The best way to check for correct ballast is to measure amount of travel reduction (% slip) of the drive wheels. Add more weight to drive wheels if slip is above 12%. If there is less than 8% slip, remove wheel weights.

If a loader is attached, provide adequate ballast to rear.

Matching Ballast to Work Load

Use no more ballast than necessary, and remove ballast when it is no longer needed.

Rather than weighing machine down to pull heavy loads, try to reduce load. Pulling a lighter load at a higher speed is more economical and more efficient.

To Little Ballast		To Much Ballast	
1.	Excessive wheel slip	1.	Increased load
2.	Power loss due to churning soil	2.	Power loss due to carrying extra weight
3.	Tire wear	3.	Tire strain
4.	Fuel waste	4.	Soil compaction
5.	Lower productivity	5.	Fuel waste
		6.	Lower productivity

Ballast Limitations

Ballast is limited by tire capacity or machine capacity. Each tire has a recommended carrying capacity, see Wheels and Tires Maintenance section. If a greater amount of weight is needed for traction, consider a larger single tire.

When determining axle ballast, ensure permissible axle loads and the permissible weight are not exceeded. (See Specifications section.)

GS25068,000AA0-19-13NOV19

Front-End Ballast

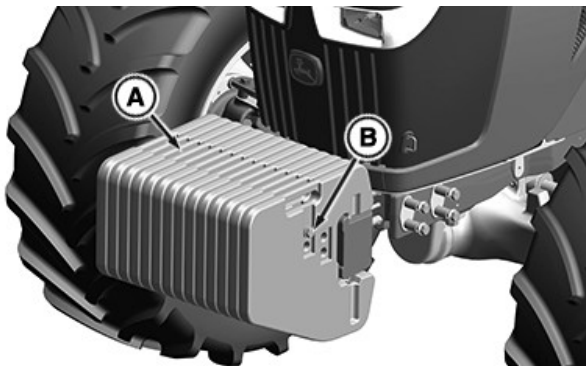

RXA0151009—UN—14JAN16

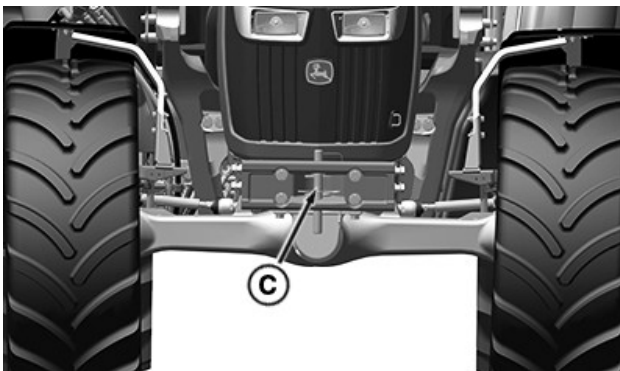

RXA0153889—UN—19SEP16

- A—Ballast Center
- B—Ballast Retaining Bolt
- C—Ballast Retaining Pin

CAUTION: Additional front ballast may be needed for rear-mounted implements. Heavy pulling and heavy rear-mounted implements tend to lift front wheels. Use proper lifting equipment for weights.

Determine the minimum number of front weights required from implement code in the implement operator’s manual.

NOTE: Quik-Tatch weights can be installed on the front of the machine up to the width of the weight bracket. Do not exceed the maximum permissible axle load (See Specifications section).

1. Install weights in pairs, one on each side of the ballast retaining pin (C). Place weights evenly on left and right sides of the retaining pin.
2. To hold six weights or fewer in position, insert retaining bolts (B) through holes and secure with a nut. Tighten to specification.

Specification

Ballast Weight Retaining

Bolt—Torque. 215 N·m
(159 lb-ft)

3. When eight or more weights are installed, insert retainers (A) between weights, one with the threaded hole upward and the other with the threaded hole downward. Insert retaining bolts (B) through holes and secure with a nut. Tighten to specification.

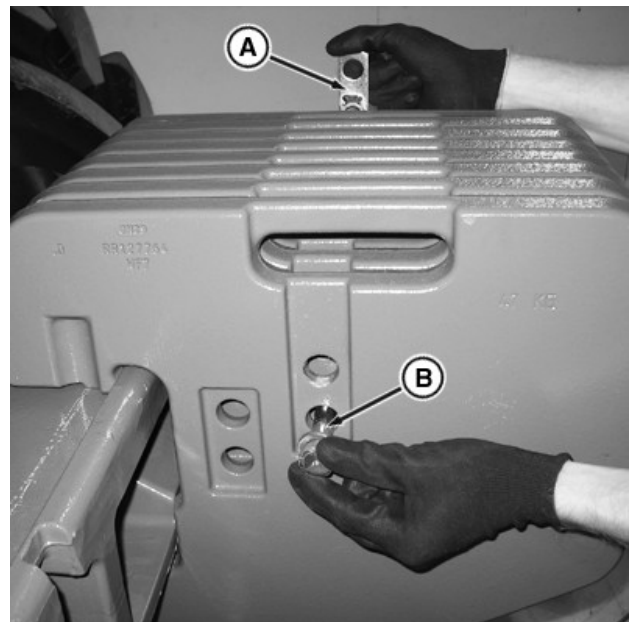

RXA0113871—UN—09FEB11

- A—Retainer
- B—Retaining Bolt

GS25068,00015DF-19-19APR21

Rear Wheel Ballast

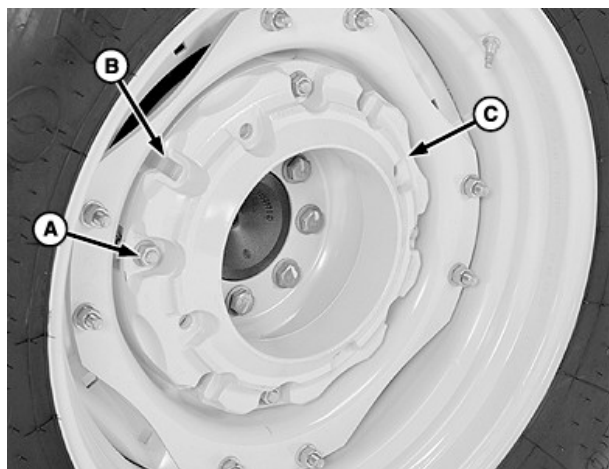

LV9684—UN—17AUG04

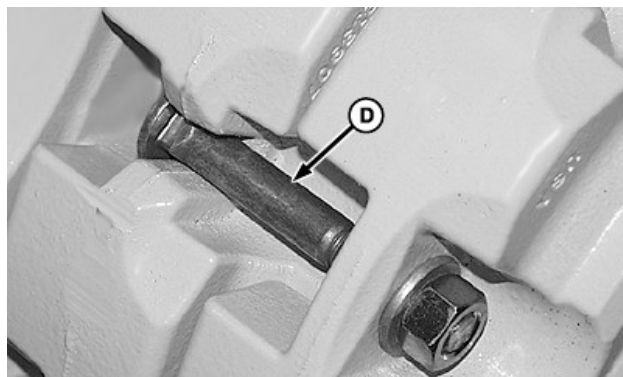

LV9692—UN—19AUG04

Install Bolt in Slot (Additional Weight)

- A—Nut, 5/8-11 (4)
- B—Slot (4)
- C—Wheel Weight
- D—Round-Head Bolt (4)

CAUTION: When installing weights, use appropriate lifting equipment or have the job performed by your John Deere Dealer.

1. Remove wheel.
2. Attach weight (C) to wheel disks using four special round-head bolts, washers, and nuts (A). Tighten nuts to specifications.

Specification

Wheel Weight-to-Disk	
Nuts—Torque.	215 N·m (159 lb·ft)

3. Install additional weights:
 - a. Insert round-head bolts (D) through slots (B) of first weight. Install bolts with the square neck in slot (as shown).
 - b. Align mounting holes of second weight with the round-headed bolts and install weight. Fasten

with washers and nuts. Tighten nuts to specifications.

Specification

Wheel Weight-to-Weight	
Nuts—Torque.	215 N·m (159 lb·ft)

4. Install wheel and tighten mounting hardware. (See Wheel and Tire Maintenance section.)
5. Retighten bolts after 3 hours, 10 hours, and every 250 hours of operation thereafter.

GS25068,00015E0-19-19APR21

Control Power Hop - MFWD

Power hop is a condition where an MFWD machine without suspension exhibits severe bounce and/or pitch motions at field working speeds when pulling a towed implement. It can occur when pulling medium to high draft loads in loose, dry soil on top of a firm base and/or when climbing hills. As a result, machine cannot maintain pull due to either loss of traction, rough ride or both. Adjust only after assuring guidelines for optimum performance with towed implements have been followed. They are:

- No more than 40% of weight can be on the front axle.
- If liquid ballast is used in rear tires, do not exceed 40% fill (4 o'clock valve stem position).
- Front and rear inflation pressures are set correctly based on static axle loads.

Then if power hop occurs:

1. Increase front inflation pressures by 40 kPa (0.4 bar) (6 psi) and operate machine.
2. If power hop still occurs:

Increase front inflation pressures by another 40 kPa (0.4 bar) (6 psi) and operate machine. Increase front inflation pressure as needed, up to a maximum of 40 kPa (0.4 bar) (6 psi) **above** the maximum pressure rating for tires. Usually 40--80 kPa (0.4—0.8 bar) (6—12 psi) above rated pressure for front axle load suffices to control power hop.
3. If power hop still occurs:

Remove all front ballast weights. Leave same front maximum inflation pressure from previous step and operate machine.
4. If power hop still occurs:

Install 75% liquid in front tires. Reinflate front tires to the maximum pressure rating for tires and operate machine.

NOTE: In most cases, step 4 is not required to control power hop.

DP51502,0002B1F-19-03FEB17

Add Liquid Ballast to Tires

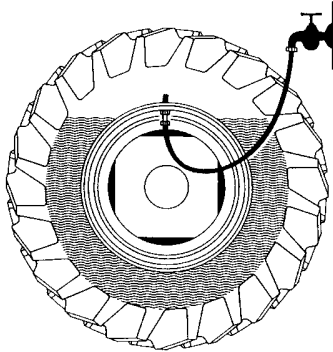

LX009450

LX009450—UN—03JAN95

To fill a tire:

1. Jack up machine and turn wheel so that the tire valve is at the top.
2. Remove valve insert and screw water valve onto the valve stem. While water is entering, air escapes through a lateral bore in the water valve.
3. Stop filling tire when water drains from the vent hole of valve. Depending on tire size, filling a tire takes 15—30 minutes. Quantity of liquid ballast required varies, depending on tire size and type. If in doubt, consult your John Deere dealer or tire manufacturer.
4. After adding liquid, screw in the air valve and pump up tire to normal inflation pressure.

For low temperature climates:

NOTE: Add calcium chloride to the water, NOT water to calcium chloride.

Do not use this antifreeze solution in radiator.

1. There are several types of liquid ballast available. Tire manufacturers recommend a mixture of water and calcium chloride. To provide protection down to -25°C (-13°F), dissolve 34 kg (75 lb) of calcium chloride in 86 L (22.7 gal) of water. This mixture makes 100 L (26.4 gal) of antifreeze solution. This solution produces an increase in weight of 120 kg (269 lb).
2. Draw antifreeze solution from an elevated tank. To speed up filling operation, use a pump (flush pump with clear water afterwards).

GS25068,0005466-19-20SEP18

Remove Liquid Ballast from Tires

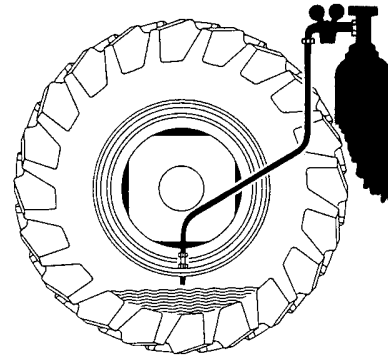

LX009451

LX009451—UN—03JAN95

1. Jack up machine.
2. Remove air valve from the tire and allow liquid to drain out.
3. Clear remainder of liquid from tire by inserting drain tube with hose extension and pump air into tire. The air pressure pushes remaining liquid out of tire.

GS25068,0003F4E-19-08FEB18

Measure Wheel Slip

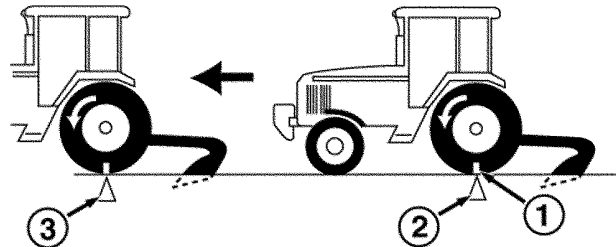

RW26776—UN—12JAN00

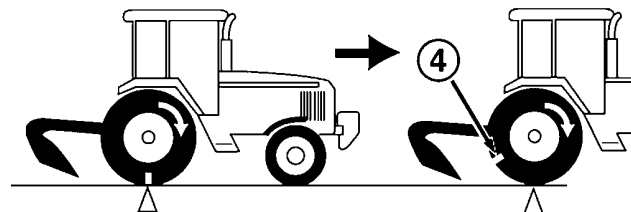

RW26777—UN—13JAN00

- 1—Mark on Tire
- 2—Mark Starting Point
- 3—Mark Ending Point After Ten Revolutions
- 4—Revolution Count with Implement Raised

IMPORTANT: Make sure that tire pressures are set for axle loads before measuring wheel slip.

1. Mark a rear tire.
2. Mark a starting point on ground with machine moving and implement lowered on ground.
3. Follow machine and mark ground again where marked tire completes ten full revolutions.
4. Repeat procedure with implement raised at same working speed. Count revolutions between same two marks.
5. Use second count and chart to determine slippage.

NOTE: Ideal slippage is 8—12% (machines with MFWD).

6. Adjust ballast or load to give correct slippage.

NOTE: Available horsepower is greatly reduced when wheel slip drops below minimum percent.

Wheel Slippage Chart		
Wheel Revolutions (Step 4)	% Slip	Result
10	0	Remove Ballast
9-1/2	5	
9	10	Correct Ballast
8-1/2	15	Add Ballast
8	20	
7-1/2	25	
7	30	

GS25068,0005467-19-20SEP18

Additional Equipment Maintenance

Front Loader Bracket Installation

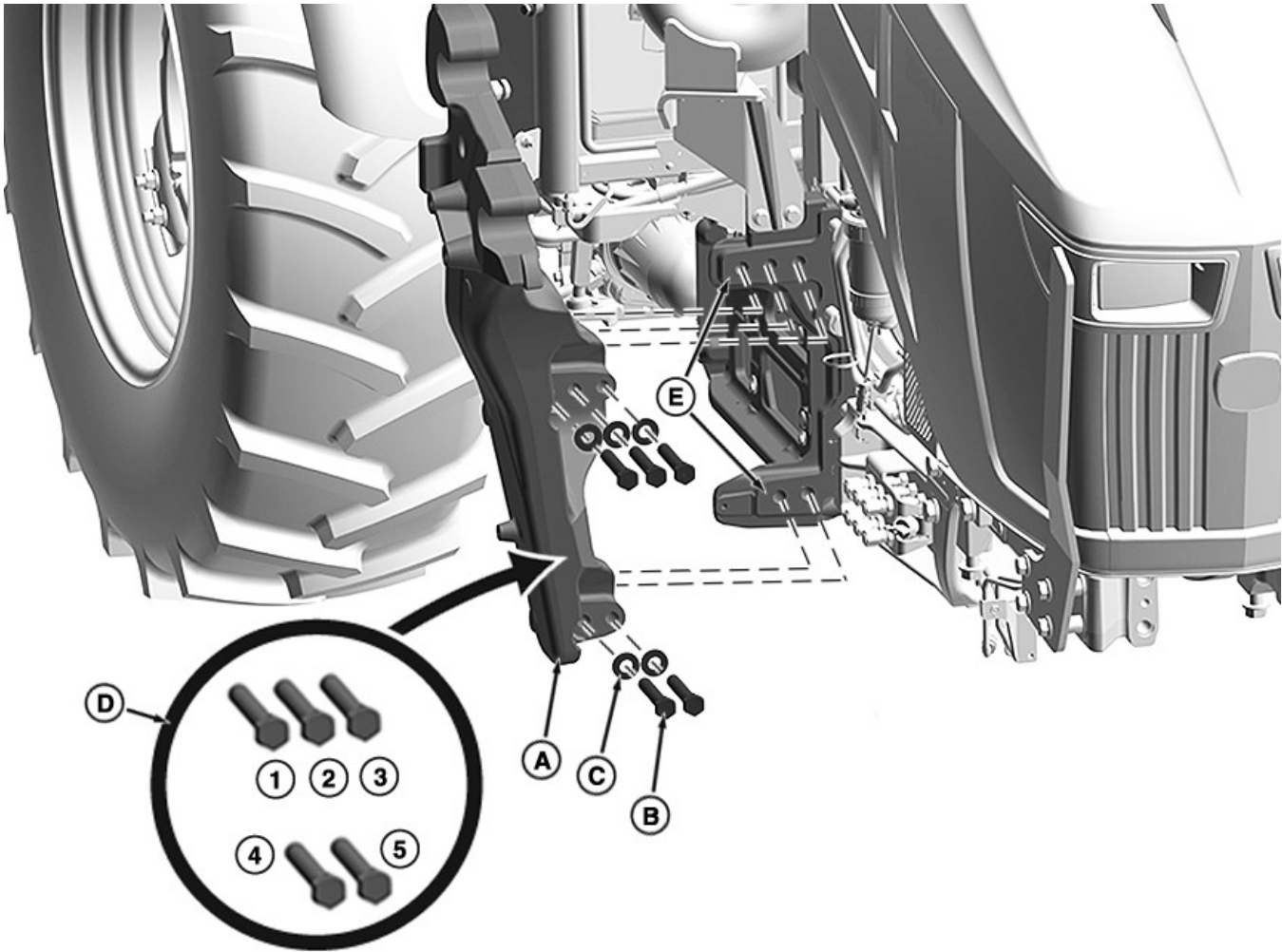

A—Front Loader Bracket (2)
 B—Hex Head Cap Screw (10)
 C—Flat Washer (10)

D—Torque Sequence
 E—Mounting Surfaces

RXA0161458—UN—31JAN18

John Deere Front Loader Bracket Hardware						
Description	Quantity	Width across Flats	Standard	Thread	Length	Identification/Grade
Hex Head Cap Screw (B)	10	30 mm	ISO 4014	M20 x 2.5	110 mm	12.9
Washer (C)	10	—	JDS 130	—	—	300HV

IMPORTANT: Attach loader brackets as shown with hardware listed in the table. Do not attach loader brackets at other points or using other hardware.

Comply with Operator's Manual and Installation Instructions of the front loader.

1. Remove any paint or debris from mounting surfaces (E).
2. Torque loader bracket bolts as indicated in the

diagram. Follow sequence as indicated 1—5. Right-hand shown, left is opposite.

Specification

Loader Mounting Bracket
 Hardware—Torque. 625 ± 62.5 N·m
 (460 ± 46 lb·ft)

3. Start on the top outward bolt first. Work inward to the machine.
4. Repeat on the bottom bracket bolts.

5. Repeat on the other bracket.
6. Check torque regularly.

GS25068,00015E2-19-19APR21

Set Pivoting Fender Brackets

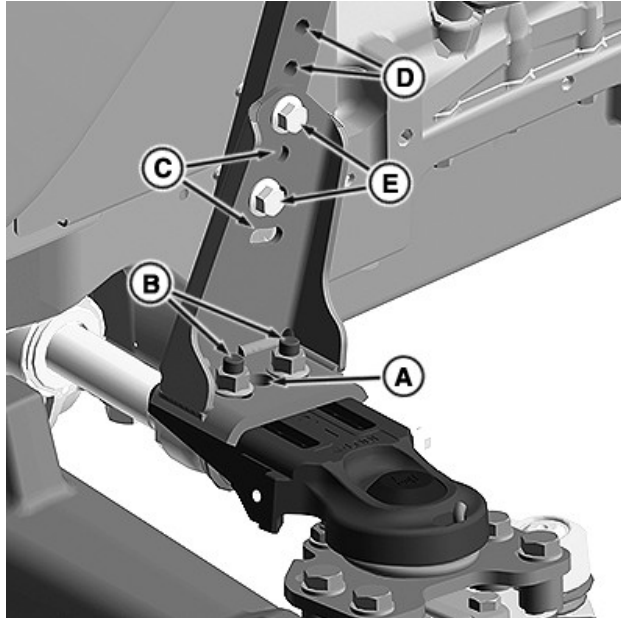

RXA0154421—UN—11NOV16

- A—Position Indicator
- B—Position Bolt (2)
- C—Height and Angle Adjustment Slot (4)
- D—Fender Arm Height Adjustment Hole (5)
- E—Height Bolts

NOTE: It is best to set fenders with the tires on the machine, resting on the ground, and inflated to intended application pressure.

1. Loosen position bolts (B) to allow fender arm to be moved in or out as needed.
2. Select a position (1—5) that allows tire clearance and centers the fender arm over the center of the tire as close as possible. Number is visible in the position indicator (A) hole in the bracket.
3. Tighten position bolts.
4. Loosen and remove height bolts (E) to change fender height.
5. Set fender height to allow clearance for tire movement and material buildup on the tire.

NOTE: Height bolts must be located correctly in the height and angle adjustment slots (C). Use the top and third slot (as shown) or the second and fourth.

6. Insert height bolts through the bracket and fender arm height adjustment holes (D) as required to obtain proper height for tire clearance.

7. Fender tilts forward or rearward to get desired clearance. Tighten bolts once position is set.
8. Additional adjustment of the fender is possible to get proper alignment. (See Set Fender Position in this section.)

GS25068,00015E3-19-19APR21

Set Fender Position

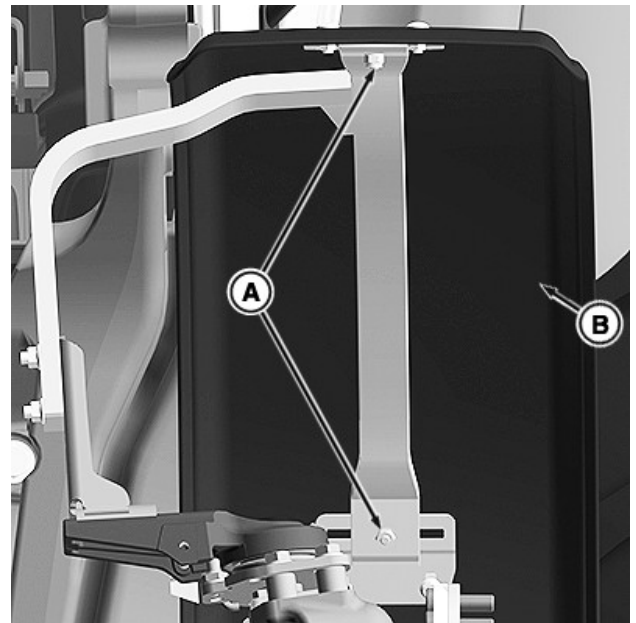

RXA0154422—UN—11NOV16

- A—Fender Bolt (2)
- B—Fender

1. To adjust fender position, loosen bolts (A).
2. Slide fender (B) inward or outward as required to center the fender over the tire.
3. Tighten bolts once position is set.
4. Verify fender clearance by turning steering wheel to left stop and right stop. If the fender contacts machine or tire, readjust brackets and fender to resolve the problem.

GS25068,00015E1-19-19APR21

Operator's Station Maintenance

Clean Cab Air Filters

MAINTENANCE INTERVAL

Every 500 Hours Cleaning filters is required more often in dusty conditions.

Every 250 Hours Change Activated Carbon Filter

IMPORTANT: Activated carbon filters can NOT be cleaned.

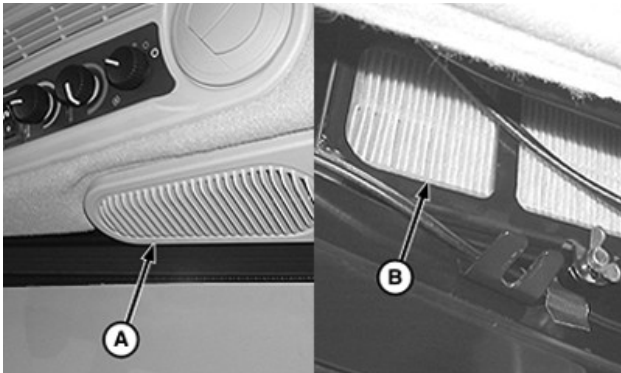

PULV000657—UN—05MAY08

Under Cab Headliner

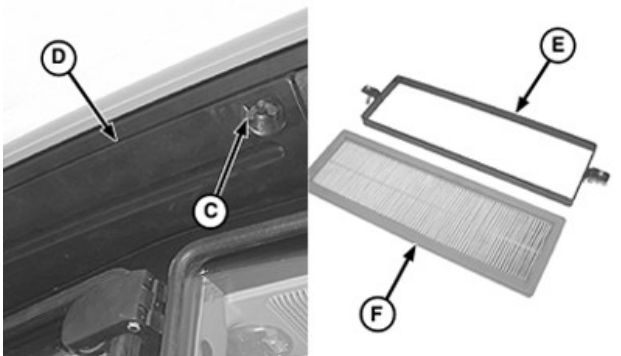

PULV000658—UN—05MAY08

Under Roof

- A—Filter Cover—Upper Right Side Shown (left side similar)
- B—Recirculated Air Filter
- C—Screws (2)
- D—Filter Cover
- E—Retainer Plate (2)
- F—Fresh Air Filter (2)

CAUTION: Check whether the cab offers sufficient protection before working in an environment containing hazardous substances (pesticides and others). Refer to the product data sheets of the spray manufacturer specifying the category required for the cab.

The air system filters are not designed to filter out harmful chemicals. Follow the implement operator's manual and chemical manufacturer instructions when using agricultural chemicals.

1. Remove filter covers (A) and filters (B).

2. Clean filters with compressed air. Inspect filters for damage. Replace as necessary.
3. Remove screws (C), filter cover (D), retainer plate (E), and filter (F) on both sides of the cab above door.
4. Clean filters with compressed air. Inspect filters for damage. Replace as necessary.

GS25068,00015E4-19-19APR21

Check Air Conditioning System

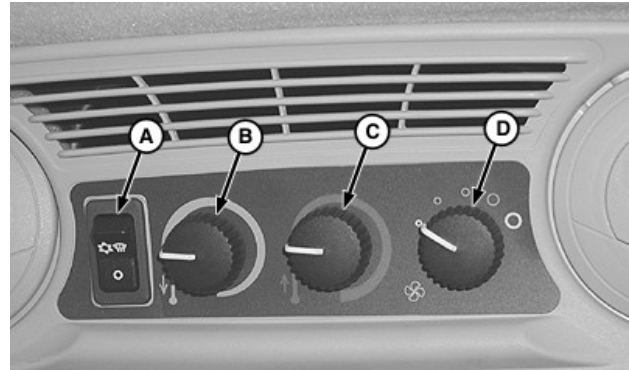

LV8415—UN—14JUL03

- A—Air Conditioner and Defog Switch
- B—Air Conditioner Temperature Control Knob
- C—Heater Temperature Control Knob
- D—Fan Speed Control Knob

Perform following checks if air conditioning system does not cool, or cooling is intermittent:

1. Confirm that system does not function correctly. Reconfirm after cleaning or adjustments are made.
 - a. Turn air conditioner and defog switch (A) on.
 - b. Set fan speed control knob (D) to highest speed.
 - c. Set temperature control knobs (B and C) to coldest setting.
 - d. Operate engine at 2000 rpm.
 - e. Check air vents to confirm that cold air is not present.
2. Inspect and clean cab air filters. Replace filters if necessary. (See Clean Air Filters in this section.)
3. Clean grille and radiator. (See Clean Grille Screens and Cooling Package in the Air, Fuel, Coolant, and Exhaust Maintenance section.)
4. If problems persist, see your John Deere dealer.

GS25068,000546C-19-20SEP18

Change Wiper Blade

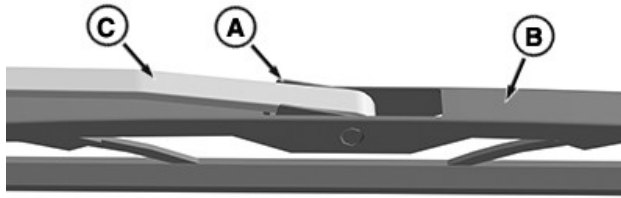

- A—Blade Retainer
- B—Wiper Blade
- C—Wiper Arm

1. Insert screwdriver in the blade retainer (A) to release.
2. Slide wiper blade (B) toward the wiper arm (C) to remove.
3. Align and slide new wiper blade into the arm until it locks into place.

RXA0154419—UN—07NOV16

GS25068,00015E7-19-19APR21

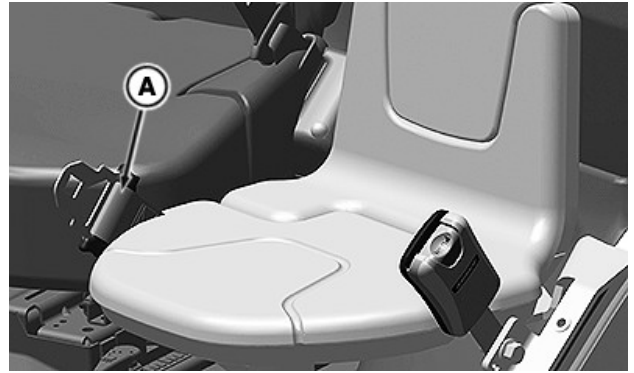

RXA0153059—UN—17AUG16

Instructional Seat Belt

A—Seat Belts

CAUTION: Inspect operator's and instructional seat belts (A), buckles, retractors, and mounting hardware. Check for any sign of damage, cuts, fraying, extreme or unusual wear, discoloration, or abrasions.

If damage is found, the entire seat belt system must be replaced immediately. Replace the belt system only with replacement parts approved for your machine. See your John Deere dealer.

GS25068,00015E6-19-06MAY21

Check Seat Belts

MAINTENANCE INTERVAL

Every 1000 Hours or Annually

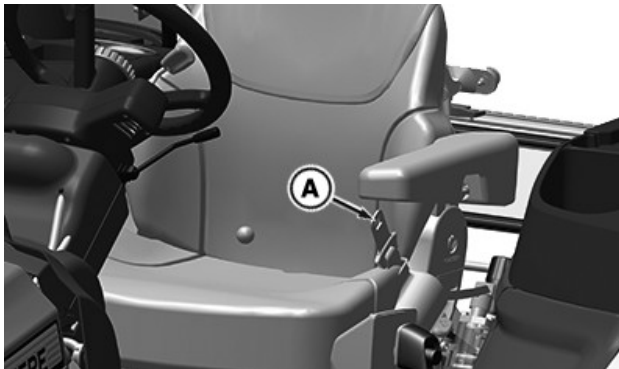

RXA0152422—UN—14JUN16

Operator's Seat Belt

Keep Cab Protection System Installed Properly

CAUTION: The manufacturer must approve any cab alteration. The cab protection system is impaired if it is subjected to structural damage, or is in any way altered by welding, bending, drilling, or cutting. A damaged cab protection system must be replaced.

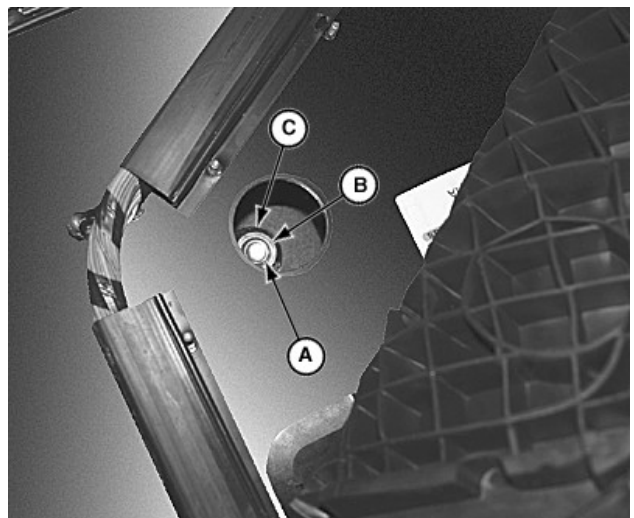

LV14682—UN—24AUG11

Front Cab Mount

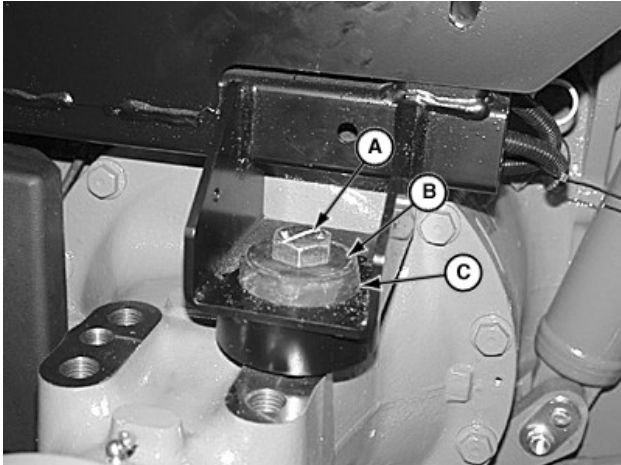

LV14683—UN—24AUG11

Rear Cab Mount

Use the provided location if mounting a StarFire receiver to the machine.

GS25068,00015E8-19-19APR21

- A—Cap Screw (2)
- B—Washer (2)
- C—Isolator (2)

NOTE: When installation of equipment on or repair of the machine necessitates loosening or removing cab protection system, replace and tighten mounting cap screws to specification.

1. To access front mounting hardware, lift up rubber floor mat and pry out plugs.
2. Check cab mounting hardware (A, B, and C) for proper torque.

Specification

Cab Mount Cap	
Screws—Torque	400 N·m (295 lb·ft)

GS25068,00015E9-19-19APR21

StarFire Receiver Mount

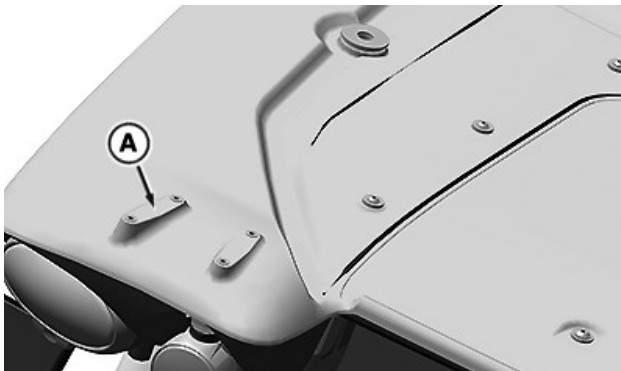

RXA0153761—UN—30AUG16

Receiver Mount

- A—Receiver Bracket Mount

Troubleshooting

Engine

Symptom	Problem	Solution
Engine turns over but does not start.	Incorrect starting procedure.	Review starting procedure.
	No fuel.	Check fuel tank.
	Exhaust restricted.	Check and correct exhaust restriction.
	Fuel filter plugged or full of water.	Replace fuel filter or drain water from filter.
	Injection pump not getting fuel or air from the fuel system.	Check fuel flow at the supply pump or bleed fuel system.
	Faulty injection pump or nozzles.	See your John Deere dealer.
Engine hard to start or does not start.	Air in fuel line.	Bleed fuel system.
	Cold weather.	Use cold weather starting procedure.
	Slow starter speed.	See Starter Turns Over Slowly in Electrical System Troubleshooting.
	Crankcase oil too heavy.	Use oil of proper viscosity.
	Improper type of fuel.	Consult fuel supplier; use the proper type of fuel for operating conditions.
	Water, dirt, or air in the fuel system.	Drain, flush, fill, and bleed system.
	Clogged fuel filter.	Replace filter element.
	Dirty or faulty injectors.	See your John Deere dealer.
	Injection pump shutoff not reset.	Turn ignition switch to STOP, then to ON.
	Engine knocks.	Low engine oil level.
Low coolant temperature.		See your John Deere dealer.
Engine runs irregularly or stalls frequently.	Low coolant temperature.	See your John Deere dealer.
	Clogged fuel filter.	Replace fuel filter element.
	Water, dirt, or air in the fuel system.	Drain, flush, fill, and bleed system.
	Dirty or faulty injectors.	See your John Deere dealer.
Below normal engine temperature.	Defective thermostat.	Remove and check thermostat.

Troubleshooting

Symptom	Problem	Solution
	Defective temperature gauge or sender.	Check gauge, sender, and conditions.
Lack of power.	Exhaust filter restriction.	See your John Deere dealer.
	Engine overloaded.	Reduce load.
	Low high idle speed.	See your John Deere dealer.
	Intake air restriction.	Service air cleaner.
	Clogged fuel filter.	Replace filter element.
	Improper type of fuel.	Use proper fuel.
	Overheated engine.	Check coolant level, inspect fan belt, and check radiator fins for debris.
	Below normal engine temperature.	See your John Deere dealer.
	Improper valve clearance.	See your John Deere dealer.
	Dirty or faulty injectors.	See your John Deere dealer.
	Turbocharger not functioning.	See your John Deere dealer.
	Leaking exhaust manifold gasket.	See your John Deere dealer.
	Implement improperly adjusted.	See implement operator's manual.
	Restricted fuel line.	See your John Deere dealer.
	Restricted return line.	See your John Deere dealer.
	Improper ballast.	Adjust ballast to load.
	Poor fuel quality.	See your John Deere dealer.
	Poor bio-fuel quality.	See your John Deere dealer.
Low oil pressure.	Low oil level.	Add oil.
	Improper type of oil.	Drain and refill crankcase with oil of proper viscosity and quality.
	Bad pump.	See your John Deere dealer.
	Bad sender.	See your John Deere dealer.
	Sender disconnected.	Connect sender.
High oil consumption.	Crankcase oil too light.	Use proper viscosity oil.

Troubleshooting

Symptom	Problem	Solution
Engine emits white smoke.	Oil leaks.	Check for leaks in lines, around gaskets and drain plugs.
	Restricted crankcase vent tube.	Clean vent tube.
	Defective turbocharger.	See your John Deere dealer.
	Improper fuel type.	Use proper fuel.
	Low engine temperature.	Warm up engine to normal operating temperature.
Engine emits black or gray exhaust smoke.	Engine out of time.	See your John Deere dealer.
	Cold start advance or light load advance not functioning.	See your John Deere dealer.
	Improper fuel type.	Use proper fuel.
	Clogged or dirty air cleaner.	Service air cleaner.
	Engine overloaded.	Reduce load or shift to a lower gear.
Engine overheats.	Engine out of time.	See your John Deere dealer.
	Turbocharger not functioning.	See your John Deere dealer.
	Engine overloaded.	Reduce load.
	Dirty radiator core or grille screen.	Remove all debris.
	Low coolant level.	Fill radiator to the proper level. Check radiator, coolant recovery tank, and hoses for loose connection or leaks.
	Stretched serpentine belt or defective belt tensioner.	Check automatic belt tensioner and check belts for stretching. Replace as required.
	Low engine oil level.	Check oil level. Add oil as required.
	Cooling system needs flushing.	See your John Deere dealer.
	Defective thermostat.	See your John Deere dealer.
	Defective temperature gauge or sender.	See your John Deere dealer.
	Incorrect grade of fuel.	Use proper fuel.
Cooling fan drive not engaged.	See your John Deere dealer.	
Dirty charge air cooler.	Clean charge air cooler fins.	

Troubleshooting

Symptom	Problem	Solution
High fuel consumption.	Improper type of fuel.	Use proper fuel.
	Clogged or dirty air cleaner.	Service air cleaner.
	Engine overloaded.	Reduce load or shift to a lower gear.
	Fuel leakage.	Check fuel supply and return line for leaks. Check fuel tank for leaks and tighten clamps.
	Improper valve clearance.	See your John Deere dealer.
	Engine out of time.	See your John Deere dealer.
	Implement improperly adjusted.	See implement operator's manual.
	Low engine temperature.	See your John Deere dealer.
	Excessive ballast.	Adjust ballast to load.
	Defective turbocharger.	See your John Deere dealer.
	Restricted air intake system.	Check system.
	Plugged crankcase vent tube.	Clean vent tube.
	Transmission oil overfilled.	Drain excess oil.
Undercharged electrical system.	Excessive electrical load from added accessories.	Remove accessories or install a higher output alternator.
	Excessive engine idling.	Increase engine rpm when heavy electrical load is used.
	Poor electrical connections on battery, ground strap, starter, or alternator.	Inspect and clean as necessary.
	Defective battery.	Test battery.
	Defective alternator.	Test charging system.
Battery uses too much water.	Cracked battery case.	Check for moisture and replace as necessary.
	Defective battery.	Test battery.
	Battery charging rate too high.	Test charging system.
Batteries do not charge.	Loose or corroded connections.	Clean and tighten connections.
	Sulfated or worn-out batteries.	See your John Deere dealer.

Troubleshooting

Symptom	Problem	Solution
	Stretched serpentine belt or defective belt tensioner.	Adjust belt tension or replace belts.
Starter does not turn over.	Loose or corroded connections.	Clean and tighten loose connections.
	Low battery output voltage.	See your John Deere dealer.
	Faulty start circuit relay.	See your John Deere dealer.
Starter turns over slowly.	Low battery output.	See your John Deere dealer.
	Crankcase oil too heavy.	Use proper viscosity oil.
	Loose or corroded connections.	Clean and tighten loose connections.
Entire electrical system does not function.	Faulty battery connection.	Clean and tighten connections.
	Sulfated or worn-out batteries.	See your John Deere dealer.

GS25068,000546F-19-20SEP18

Heat and Air Conditioning

Symptom	Problem	Solution
All cab electrical switches do not work.	Loose, defective, or blown fusible link.	See your John Deere dealer.
Blower malfunctioning.	Blower does not work.	Check both blower fuses.
Blower operates only in purge position.	One of two fuses blown.	Replace fuse.
	Blown blower resistance assembly.	See your John Deere dealer.
Heater does not work.	Low coolant level.	Check coolant level; add if necessary.
	Faulty thermostat.	See your John Deere dealer.
	Heater control valve not functioning properly.	See your John Deere dealer.
	Heater core or hoses clogged or damaged.	Flush cooling system. See your John Deere dealer. Replace heater core or hoses. See your John Deere dealer.
Air conditioning does not work.	Fan belt loose or slipping.	Check belt tension. Replace belt if necessary.
	Blown fuse.	Replace fuse.
	Defective switch.	See your John Deere dealer.

Troubleshooting

Symptom	Problem	Solution
	Faulty wiring or loose connections.	See your John Deere dealer.
	Defective compressor clutch.	See your John Deere dealer.
	Condenser dirty.	Clean condenser.
	Heater valve leaking.	See your John Deere dealer.
	No Freon charge.	See your John Deere dealer.
Drafts.	Poor air distribution.	Adjust directional air louvers. Set blower switch to medium or low position.
Inadequate air flow.	Clogged air filters.	Clean filters.
	Evaporator core air flow restricted.	Clean evaporator and housing with compressed air.
	Faulty blower fan motors.	See your John Deere dealer.
	Defective blower switch.	See your John Deere dealer.
	Faulty wiring or loose connections.	See your John Deere dealer.
Water leaking or dripping from evaporator core compartment.	Loose hose clamp.	Tighten clamp.
	Air-conditioning drip pan dirty.	Clean evaporator pan and outlet with compressed air.
	Air-conditioning drain tubes plugged.	Clean drain tubes.
Strange odors inside cab.	Dirty air filters.	Clean filters.
	Evaporator condenser pan dirty.	Clean pan and outlet with compressed air.
	Drain tubes plugged.	Clean drain tubes.
	Foreign substance on the evaporator exterior.	Clean filters.
Partial frosting and sweating of lines combined with poor cooling.	Cooling fan belt slipping.	Check belt tension. Replace belt if necessary.
	Loss of refrigerant.	Check system for leaks. See your John Deere dealer.
	Restricted or clogged liquid line.	See your John Deere dealer.
	Expansion valve malfunctioning.	See your John Deere dealer.

Troubleshooting

Symptom	Problem	Solution
Ice flecks blowing from evaporator.	Control dial set too low.	Adjust the temperature control to a warmer position.
Failure to cool.	Insufficient blower speed.	Increase blower speed.
	Dirty air filters.	Clean filters.
	Debris on the front grille.	Clean front grille.
	Lint or dirt on condenser fins.	Blow out condenser fins with compressed air.
	Refrigerant is lost or low.	See your John Deere dealer.
	Loose cooling fan belt.	Check belt tension. Replace belt if necessary.
	Compressor clutch not engaging.	See your John Deere dealer.
	Expansion valve not functioning.	See your John Deere dealer.
	Restriction in the refrigerant system.	See your John Deere dealer.
	Faulty wiring or loose connections.	See your John Deere dealer.
	Defective temperature control switch.	See your John Deere dealer.
	Outside temperature too low, below 21°C (70°F).	Wait until day gets warmer. If there is a malfunction in system, see your John Deere dealer.
	Condenser is overheating.	Clean condenser screens, cores, and fins of condenser and radiator.
	Severe restriction in the high side.	See your John Deere dealer.
	Burned out clutch field or faulty field.	See your John Deere dealer.
	Short circuit in the control circuit or failure of a switch in circuit.	See your John Deere dealer.
	Cooling fan drive not engaged.	See your John Deere dealer.
Hissing noise at the expansion valve.	Loss of refrigerant.	Check system for leaks. See your John Deere dealer.
	Restriction in the refrigerant system.	Check for kinks in hoses. Check receiver-drier for uniformity of temperature. See your John Deere dealer.

GS25068,0005470-19-20SEP18

Electrical

Symptom	Problem	Solution
Battery does not charge.	Loose or corroded connections.	Clean and tighten connections.
	Sulfated or worn-out battery.	See your John Deere dealer.
	Loose or defective cooling fan belt.	Check belt tension. Replace belt if necessary.
Charging system diagnostic trouble codes are present.	Low engine speed.	Increase speed.
	Defective battery.	See your John Deere dealer.
	Defective alternator.	See your John Deere dealer.
	Slipping fan belt.	Check belt tension. Replace belt if necessary.
Starter inoperative.	Low battery output.	See your John Deere dealer.
	Blown fuse.	Replace fuse.
	Left-hand reverser in forward or reverse.	Move lever to Park or Neutral.
	Bypass starter circuit.	See your John Deere dealer.
Starter turns over slowly.	Low battery output.	See your John Deere dealer.
	Crankcase oil too heavy.	Use proper viscosity oil.
	Loose or corroded connections.	Clean and tighten loose connections.
Light system does not function; rest of the electrical system functions.	Blown fuse.	Replace fuse.
Worklights do not work.	Blown fuse.	Replace fuse.
	Defective bulb or switch.	Replace bulb or see your John Deere dealer.
	Faulty wiring or loose connections.	See your John Deere dealer.
Dome light does not work.	Blown fuse.	Replace fuse.
	Defective bulb or switch.	Replace bulb or see your John Deere dealer.
	Defective door switch.	See your John Deere dealer.
	Faulty wiring or loose connections.	See your John Deere dealer.

Troubleshooting

Symptom	Problem	Solution
All cab electrical switches do not work.	Loose, defective, or blown fusible link.	See your John Deere dealer.
Window wipers and washer do not operate.	Blown fuse.	Replace fuse.
	Defective switches.	See your John Deere dealer.
	Defective motors.	See your John Deere dealer.
	Faulty wiring or loose connections.	See your John Deere dealer.
Radio does not work.	Blown fuse.	Replace fuse.
Entire electrical system does not function.	Faulty battery connections.	Clean and tighten connections.
	Sulfated or worn-out battery.	See your John Deere dealer.
	Blown fuse.	Replace fuse.

GS25068,0005471-19-20SEP18

Transmission

Symptom	Problem	Solution
Transmission oil overheats.	Low oil supply.	Fill system with correct oil.
	Clogged transmission/hydraulic oil filter.	Replace filter.
	Internal hydraulic leak.	See your John Deere dealer.
	Implement-mounted hydraulic motor not plumbed correctly or matched to circuit.	See your John Deere dealer.
	SCV lever held in extend or retract position.	Return SCV lever to neutral position.
	Transmission oil over full mark.	Drain to the full mark.
	Oil cooler dirty.	Clean oil cooler.
	Hitch feedback linkage improperly adjusted.	Adjust linkage. See your John Deere dealer.
	Cooling fan drive not engaged.	See your John Deere dealer.
Low transmission pressure.	Low oil supply.	Fill system with correct oil.
	Clogged transmission/hydraulic oil filter.	Replace filter.

GS25068,0005472-19-20SEP18

Brakes

Symptom	Problem	Solution
Pedal feels soft and brakes do not perform well.	Air in system.	See your John Deere dealer.
Pedal settles.	Rear brake piston seal leaking.	See your John Deere dealer.
Excessive pedal travel.	Air in system.	See your John Deere dealer.
Brakes drag during transport.	Brakes out of adjustment.	See your John Deere dealer.

DP51502,0002B30-19-03FEB17

Hydraulics

Symptom	Problem	Solution
Entire hydraulic system fails to function.	Low oil supply.	Fill system with correct oil.
	Clogged transmission/hydraulic oil filter.	Replace filter.
	High-pressure internal leak.	See your John Deere dealer.
Hydraulic oil overheats.	Low oil supply.	Fill system with correct oil.
	Clogged transmission/hydraulic oil filter.	Replace filter.
	Internal hydraulic leak.	See your John Deere dealer.
	Implement-mounted hydraulic motor not plumbed correctly or matched to circuit.	See your John Deere dealer.
	SCV lever held in extend or retract position.	Return SCV lever to neutral position.
	Flow control or detent setting incorrect.	Adjust flow control and/or detent setting.
	Hitch feedback linkage improperly adjusted.	Adjust linkage. See your John Deere dealer.
Direction of remote cylinder travel is reversed.	Improper hose connections.	Reverse hose connections.
Hoses do not couple.	Improper hose male tips.	Replace tip with ISO standard tips.
Remote cylinder does not lift load.	Excessive load.	Reduce load.
	Hoses not installed correctly.	Attach hoses correctly.

Troubleshooting

Symptom	Problem	Solution
	Incorrect remote cylinder size.	Use correct cylinder size.

GS25068,0001905-19-29JUL21

Hitch

Symptom	Problem	Solution
Insufficient transport clearance.	Center link too short.	Adjust center link.
	Lift links too short.	Adjust lift links.
	Implement not level.	Level implement.
	Hitch feedback linkage not properly adjusted.	See your John Deere dealer.
	Implement not properly adjusted.	See implement operator's manual.
	Front of center link in upper holes.	Move center link to lower holes.
	Sway bars too short.	Adjust sway bars.
	Raise height limit not correctly set.	Adjust raise height limit.
Hitch fails to follow the lever.	Malfunction in the lever position sensor or hitch position sensor.	See your John Deere dealer.
Poor position control.	Load/depth mix control in wrong position.	Turn load/depth mix control to "position" control detent.
	System is reset (fender switches override operator's control).	Enable system with operator's control.
	Malfunction in the lever position sensor or hitch position sensor.	See your John Deere dealer.
Hitch drops slowly.	Rate-of-drop control not properly set.	Adjust rate-of-drop.
Hitch fails to lift or lifts slowly.	Excessive load on hitch.	Reduce load.
	Center link in wrong position.	Adjust center link.
	Low oil level.	Fill system with proper oil.
	Hydraulic oil too cold.	Allow oil to warm.
	Transmission/hydraulic oil filter clogged.	Replace filter.
Implement does not operate at desired depth.	Lift links too short.	Adjust lift links.
	Lack of penetration.	See implement operator's manual.

Troubleshooting

Symptom	Problem	Solution
	Draft sensor failed.	See your John Deere dealer.
	Improper setting of the hitch control stop.	Adjust position.
	Improper setting of load/depth control.	Adjust load/depth for the implement type.
Insufficient or no hitch response to draft load.	Load/depth control in position 1.	Turn load/depth mix control to higher setting.
	Lift links too short.	Adjust lift links.
	Lack of penetration.	See implement operator's manual.
	System is reset.	Enable system.
	Rate-of-drop too slow.	Adjust rate-of-drop.
Hitch too responsive.	Load/depth mix control not correctly set.	Turn load/depth mix control to lower setting.
Hitch drops too fast.	Rate-of-drop set too fast.	Adjust rate-of-drop.
Hitch settles too fast after machine is parked and engine shut off.	Internal system leakage.	See your John Deere dealer.
Hitch does not move (controls not working, including external raise/lower switch).	Fuses blown.	Replace fuses.
External raise/lower switch does not move hitch.	Failure of the raise/lower switch, connector, or wiring harness.	See your John Deere dealer.
Hitch codes are present.	One or more hitch component failures.	See your John Deere dealer.

GS25068,0005474-19-20SEP18

Selective Control Valves (SCV)

Symptom	Problem	Solution
Flow control knob or detent does not turn.	Dirt buildup.	Clean dirt from the flow control knob shaft.
Remote cylinders rate-of-travel too fast or too slow.	Incorrect flow control adjustment.	Adjust flow control.
Detent does not hold SCV lever.	Detent selector in wrong position.	Turn selector to correct position.
	Flow control or detent setting incorrect.	Adjust flow control and detent setting.
	Low engine rpm.	Increase engine rpm.

Troubleshooting

Symptom	Problem	Solution
	Pressure restriction with some implements.	Reduce oil flow by changing flow control setting.
	Mid-Mount SCV activated.	Avoid use of mid-mount SCV.
	Hitch activated.	Avoid use of hitch.
SVC lever releases too soon.	Detent selector in wrong position.	Turn selector to correct position.
	Kick out pressure setting incorrect.	See your John Deere dealer.
SCV lever does not release.	Detent selector not in automatic detent position.	Turn selector to correct position. See your John Deere dealer.
	Built-in pressure leakage with some implements.	Increase oil flow by changing flow control setting.
	Incorrect flow control.	Adjust flow control.
	Overtorqued cable-to-valve connection.	Adjust torque at the connector.
Rear SCV fails to function.	Rear SCV does not generate pressure.	Check power beyond fitting in mid-mount SCV.

GS25068,00018A5-19-23JUL21

On-Board Diagnostics

STOP, Service, Information Alert Indicators, and Alarms

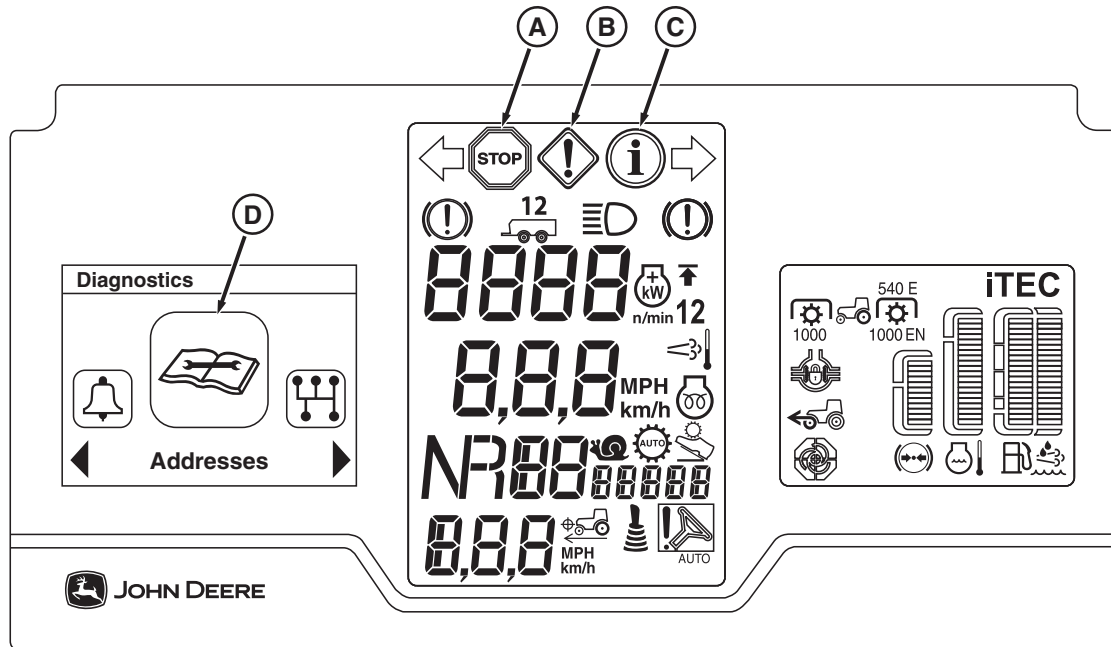

RXA0180998—UN—20APR21

A—STOP Alert Indicator
B—Service Indicator

IMPORTANT: Capture information regarding operating conditions, machine performance, and environment whenever any alert or alarm is active. Use information to self-correct operation, or contact your John Deere dealer for assistance.

Alarm conditions are visually communicated using alert indicators for STOP alert indicator (A), service indicator (B), and information indicator (C). Audible alarms (beeping or continuous) accompany alert indicators and/or diagnostic trouble code indicator (D).

STOP alert indicator (A) represents an urgent warning. Immediate attention or service is required in order to prevent serious malfunction or damage. Engine or function shuts down. Do not continue operation. Contact your John Deere dealer to diagnose the problem.

Service alert indicator (B) represents a performance/protection warning. Immediate attention or operation is required in order to prevent reduced performance, malfunction, or damage. Adjust operating conditions or conduct maintenance. Contact your John Deere dealer as needed.

Information alert indicator (C) represents an informational warning. Attention or adjustment may be required in order to maintain performance and prevent a more severe alert condition. Adjust operating conditions

C—Information Indicator
D—Diagnostic Trouble Code Indicator

or conduct maintenance. Contact your John Deere dealer as needed.

Diagnostic trouble code indicator (D) illuminates when a condition occurs that triggers a code to set. Other indicator lights may illuminate, which corresponds to a functional system of the machine when alarms and indicators are present. Severity levels for alarms are as follows, from the highest level of priority to the lowest:

1. STOP alert indicator (A)
2. Operator out of seat
3. Service indicator (B)
4. Information indicator (C)

For display details, see Displays, Software, and Electronics Operation section and further details in this section.

Contact your John Deere dealer for troubleshooting assistance. Your dealer has additional access to the information display and tools to diagnose and repair problems.

D3K5H22.0000553-19-03MAR21

Diagnostics Menu

NOTE: For additional navigation information, see Basic Menu Navigation in the Displays, Software, and Electronics Operation section.



Diagnostics Menu

RXA0152980—UN—21JUL16



Diagnostic Trouble Codes Selection

RXA0152981—UN—25JUL16



Addresses Selection

RXA0152980—UN—21JUL16

1. Locate the diagnostics menu.

2. Select and enter the desired selection. See the relevant topic in this section for additional details on selections.

Selection	Range	Display Response
Diagnostic Trouble Codes	Diagnostic trouble codes listed by functional area.	Displays active and stored diagnostic trouble codes.
Addresses	Addresses listed by functional area.	Displays addresses that the operator can view or adjust.

D3K5H22.0000539-19-04JUN21

Diagnostic Trouble Codes

NOTE: For additional navigation information, see Basic Menu Navigation in the Displays, Software, and Electronics Operation section.

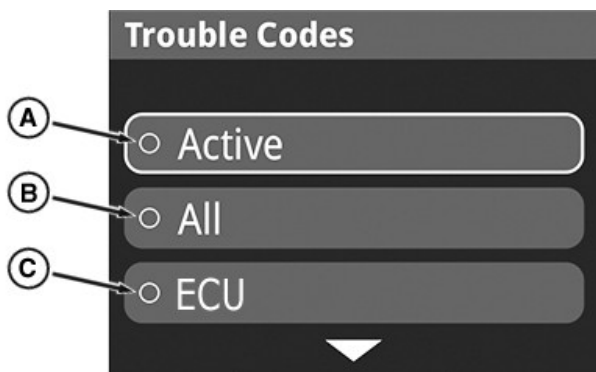

Diagnostic Trouble Code Menu

RXA0153445—UN—19AUG16

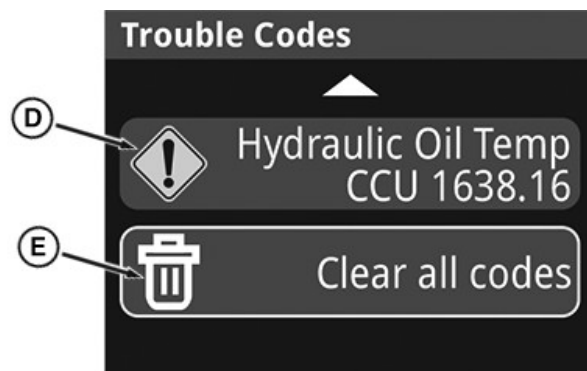

Diagnostic Trouble Code List

RXA0153446—UN—19AUG16

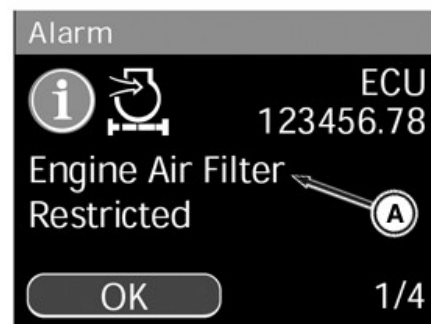

Example (code information)

RXA0152424—UN—28OCT16

- A—Active Codes
- B—All Codes
- C—Control Unit Codes
- D—Diagnostic Trouble Code
- E—Clear All Codes Function

1. Access the diagnostic trouble code menu. A list appears, allowing the operator to choose which code groupings they want to see.
 - a. Active (A) - only the codes that are currently occurring on the machine.
 - b. All (B) - all codes that have occurred or are currently occurring. This selection allows the operator to clear diagnostic trouble codes.
 - c. Control unit code (C) (ECU - engine control unit) - only shows codes related to that control unit.
2. Selecting All (B) provides the most information and allows for clearing of codes. Press the confirm button to navigate to the code list. It takes several seconds, possibly longer, to pull all of the codes.
3. Once the list of diagnostic trouble codes appears, navigate to and select a code (D) to find more information about it.
4. After selecting a code, use the navigation dial to scroll down the text if an arrow appears near the bottom of the page. Selecting "OK" at the bottom of the page acknowledges the code.
5. Return to the code list and review other codes as desired.
6. Once codes have been reviewed, scroll to the bottom of the code list and use clear all codes (E). Select this option and depress the confirm button to remove all of the stored and active codes.
7. The message "No codes stored" appears.
8. Use the back button to return to the main menu.

Contact your John Deere dealer for troubleshooting assistance. Your dealer has additional access to the on-board display and tools to diagnose and repair problems.

D3K5H22,00005D6-19-21APR21

Addresses

NOTE: For additional navigation information, see Basic Menu Navigation in the Displays, Software, and Electronics Operation section.

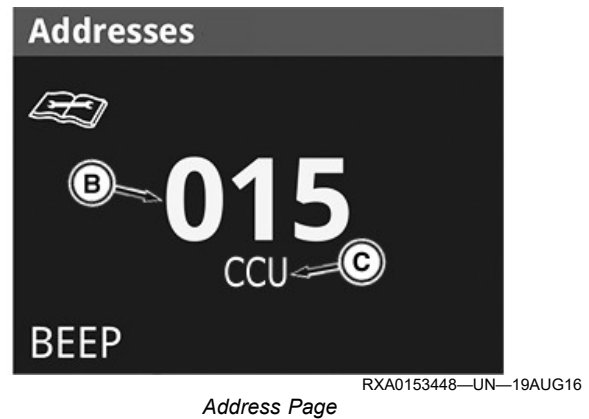
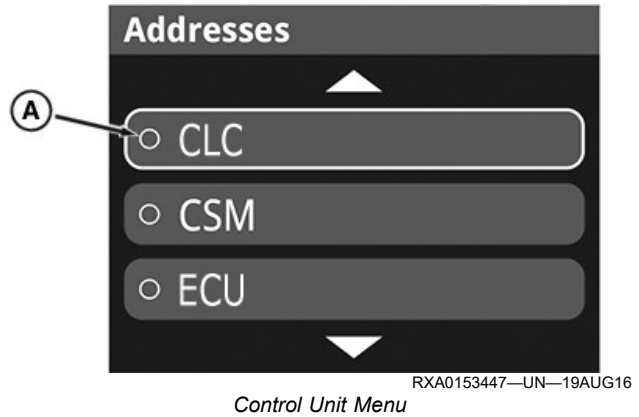

- A—Control Unit Selection
- B—Address Number
- C—Control Unit Acronym

1. Access the address menu. A list appears, allowing the operator to choose which control unit they want to see.
2. Scroll down and choose the control unit selection (A) for the relevant information the operator would like to view or configure.
3. The page with the address number (B) and control unit acronym (C) opens.
4. Use the navigation dial to scroll through the addresses. Depress the confirm button to select an address to view additional information.
 - a. Address 1 is a list of stored diagnostic trouble codes for that selected control unit software. (See Diagnostic Trouble Codes in this section.)
 - b. Address 2 is a beep mode. Operate a control device (switch, button, lever) to see an address number display, a value change state, and sound an audible beep.
 - c. Addresses 3—199 are various feature or function information related to status, configuration, and operation.
 - d. Addresses 200—251 are related to software and hardware numbers and versions.

5. If an address is configurable by the operator, there is an "Edit" icon in the lower right-hand corner. Selecting the edit option allows changes to the values used by the software. It is not recommended to change values unless the user fully understands what is being changed. Contact your John Deere dealer for more information.
6. After entering the edit mode, the confirm button moves the selection box and the navigation dial changes the value within the selection box.
7. After the value has been changed, the back button navigates to a "Cancel" or "Save" screen. Depressing the back button again cancels changes, and the confirm button saves changes.

Contact your John Deere dealer for troubleshooting assistance. Your dealer has additional access to the on-board display and tools to diagnose and repair problems.

D3K5H22,00005D7-19-21APR21

CAN Bus

Accessing Controller Area Network (CAN) bus information page displays status of communication between the control units on CAN bus. Machine CAN bus connects control units such as engine, hydraulics, and transmission.

Network Status

- Active - System is working as expected. In addition to display, at least one control unit is connected and communicating on CAN bus.
- Inactive - Display is not communicating with any other control units on CAN bus. If the display is the only control unit on CAN bus, Total Message Count increases, but network status is inactive.
- Error - Display is not communicating with CAN bus.

Message Count

Message count is the number of messages sent over CAN bus. When machine is running, this value counts up continuously since there are always messages sent on CAN bus.

CAN Hi and CAN Lo Voltage

Peak voltage is highest average voltage that has occurred since last cold boot. Peak CAN high and peak CAN low voltages normally range between 1.8 and 3.3 Volts.

NOTE: A cold boot occurs after display has been off for 24 hours or all power has been disconnected from display.

Bus Utilization

If a control unit or implement is not running as expected,

bus utilization of 45% or higher could be the reason. Some devices cannot send and receive all necessary messages if bus load is too high.

NOTE: Some ISOBUS implements do not work with bus loads higher than 25%.

Unplugging implements or GPS receivers can reduce bus utilization.

Baud Rate

NOTE: Machine and implement CAN Bus run at different speeds or baud rates.

Baud rate indicates how fast the CAN bus is working. Any control unit connected to this system must work at 500 kbd. Any device operating at a different baud rate does not function properly.

CAN Bus Status

- Active - CAN bus is running without any problems.
- Inactive - CAN bus is not communicating as expected and has stopped.
- Error - CAN bus errors have occurred.

Error Counts

If one of these errors occurs, display records number of times it happens.

Passive Error Count - If value counts up higher than zero, a control unit on CAN bus did not receive all messages. Important information might have been lost, most likely due to high CAN bus utilization.

CAN Bus Warn Count - If value counts up higher than zero, a control unit on CAN bus has issues.

CAN Bus Off Count - If value counts up higher than zero, a control unit on CAN bus has issues. It missed a certain number of messages and does not receive messages anymore. Important information has been lost. It most likely occurs in combination with high CAN bus utilization.

Overrun Error Count - Indicates that applications or control units on CAN bus receive messages faster than they can process them. The result is missing messages and system malfunctions. It most likely occurs in combination with high CAN bus utilization.

GS25068,0005863-19-30OCT18

Specifications

Metric Bolt and Screw Torque Values

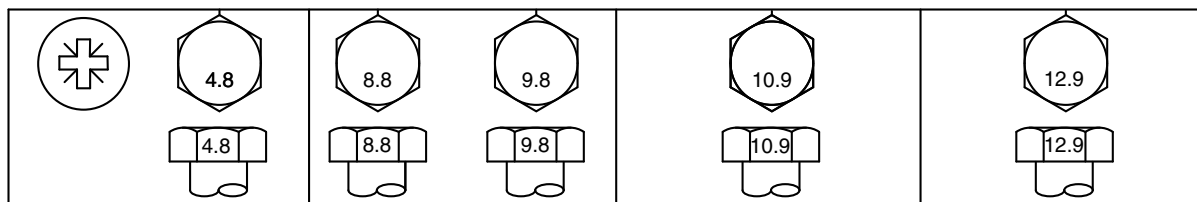

TS1742—UN—31MAY18

Bolt or Screw Size	Class 4.8				Class 8.8 or 9.8				Class 10.9				Class 12.9			
	Hex Head ^a		Flange Head ^b		Hex Head ^a		Flange Head ^b		Hex Head ^a		Flange Head ^b		Hex Head ^a		Flange Head ^b	
	N·m	lb·in	N·m	lb·in	N·m	lb·in	N·m	lb·in	N·m	lb·in	N·m	lb·in	N·m	lb·in	N·m	lb·in
M6	3.6	31.9	3.9	34.5	6.7	59.3	7.3	64.6	9.8	86.7	10.8	95.6	11.5	102	12.6	112
M8	8.6	76.1	9.4	83.2	16.2	143	17.6	156	23.8	17.6	25.9	19.1	27.8	20.5	30.3	22.3
M10	16.9	150	18.4	13.6	31.9	23.5	34.7	25.6	46.8	34.5	51	37.6	55	40.6	60	44.3
M12	—	—	—	—	55	40.6	61	45	81	59.7	89	65.6	95	70.1	105	77.4
M14	—	—	—	—	87	64.2	96	70.8	128	94.4	141	104	150	111	165	122
M16	—	—	—	—	135	99.6	149	110	198	146	219	162	232	171	257	190
M18	—	—	—	—	193	142	214	158	275	203	304	224	322	245	356	263
M20	—	—	—	—	272	201	301	222	387	285	428	316	453	334	501	370
M22	—	—	—	—	365	263	405	299	520	384	576	425	608	448	674	497
M24	—	—	—	—	468	345	518	382	666	491	738	544	780	575	864	637
M27	—	—	—	—	683	504	758	559	973	718	1080	797	1139	840	1263	932
M30	—	—	—	—	932	687	1029	759	1327	979	1466	1081	1553	1145	1715	1265
M33	—	—	—	—	1258	928	1398	1031	1788	1319	1986	1465	2092	1543	2324	1714
M36	—	—	—	—	1617	1193	1789	1319	2303	1699	2548	1879	2695	1988	2982	2199

The nominal torque values listed are for general use only with the assumed wrenching accuracy of 20%, such as a manual torque wrench. DO NOT use these values if a different torque value or tightening procedure is given for a specific application. For lock nuts, for stainless steel fasteners, or for nuts on U-bolts, see the tightening instructions for the specific application.

Replace fasteners with the same or higher property class. If higher property class fasteners are used, tighten these to the strength of the original.

- Make sure that fastener threads are clean.
- Apply a thin coat of Hy-Gard™ or equivalent oil under the head and on the threads of the fastener, as shown in the following image.
- Be conservative with the amount of oil to reduce the potential for hydraulic lockup in blind holes due to excessive oil.
- Properly start thread engagement.

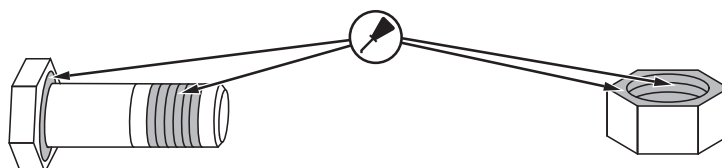

TS1741—UN—22MAY18

^aHex head column values are valid for ISO 4014 and ISO 4017 hex head, ISO 4162 hex socket head, and ISO 4032 hex nuts.

^bHex flange column values are valid for ASME B18.2.3.9M, ISO 4161, or EN 1665 hex flange products.

DX,TORQ2-19-09MAY22

Unified Inch Bolt and Screw Torque Values

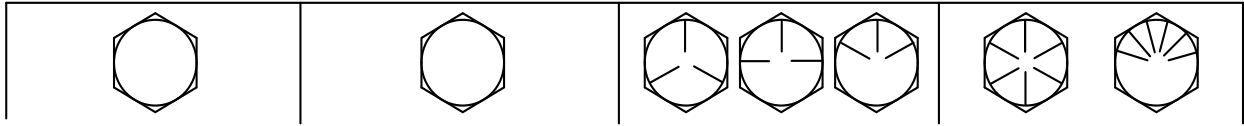

TS1671—UN—01MAY03

Bolt or Screw Size	SAE Grade 1 ^a				SAE Grade 2 ^b				SAE Grade 5, 5.1 or 5.2				SAE Grade 8 or 8.2			
	Hex Head ^c		Flange Head ^d		Hex Head ^c		Flange Head ^d		Hex Head ^c		Flange Head ^d		Hex Head ^c		Flange Head ^d	
	N·m	lb·in	N·m	lb·in	N·m	lb·in	N·m	lb·in	N·m	lb·in	N·m	lb·in	N·m	lb·in	N·m	lb·in
1/4	3.1	27.3	3.2	28.4	5.1	45.5	5.3	47.3	7.9	70.2	8.3	73.1	11.2	99.2	11.6	103
5/16	6.1	54.1	6.5	57.7	10.2	90.2	10.9	96.2	15.7	139	16.8	149	22.2	16.4	23.7	17.5
3/8	10.5	93.6	11.5	102	17.6	156	19.2	170	27.3	20.1	29.7	21.9	38.5	28.4	41.9	30.9
7/16	16.7	148	18.4	163	27.8	20.5	30.6	22.6	43	31.7	47.3	34.9	60.6	44.7	66.8	49.3
1/2	25.9	19.1	28.2	20.8	43.1	31.8	47	34.7	66.6	49.1	72.8	53.7	94	69.3	103	75.8
9/16	36.7	27.1	40.5	29.9	61.1	45.1	67.5	49.8	94.6	69.8	104	77	134	98.5	148	109
5/8	51	37.6	55.9	41.2	85	62.7	93.1	68.7	131	96.9	144	106	186	137	203	150
3/4	89.5	66	98	72.3	149	110	164	121	230	170	252	186	325	240	357	263
7/8	144	106	157	116	144	106	157	116	370	273	405	299	522	385	572	422
1	216	159	236	174	216	159	236	174	556	410	609	449	785	579	860	634
1-1/8	305	225	335	247	305	225	335	247	685	505	751	554	1110	819	1218	898
1-1/4	427	315	469	346	427	315	469	346	957	706	1051	775	1552	1145	1703	1256
1-3/8	564	416	618	456	564	416	618	456	1264	932	1386	1022	2050	1512	2248	1658
1-1/2	743	548	815	601	743	548	815	601	1665	1228	1826	1347	2699	1991	2962	2185

The nominal torque values listed are for general use only with the assumed wrenching accuracy of 20%, such as a manual torque wrench. DO NOT use these values if a different torque value or tightening procedure is given for a specific application. For lock nuts, for stainless steel fasteners, or for nuts on U-bolts, see the tightening instructions for the specific application.

Replace fasteners with the same or higher property class. If higher property class fasteners are used, tighten these to the strength of the original.

- Make sure that fastener threads are clean.
- Apply a thin coat of Hy-Gard™ or equivalent oil under the head and on the threads of the fastener, as shown in the following image.
- Be conservative with the amount of oil to reduce the potential for hydraulic lockup in blind holes due to excessive oil.
- Properly start thread engagement.

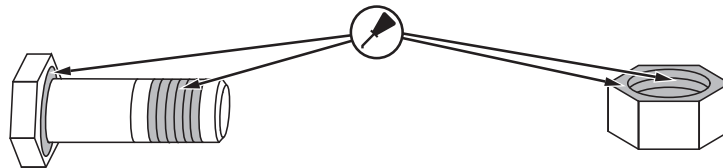

TS1741—UN—22MAY18

^aGrade 1 applies for hex cap screws over 6 in (152 mm) long, and for all other types of bolts and screws of any length.

^bGrade 2 applies for hex cap screws (not hex bolts) up to 6 in (152 mm) long.

^cHex head column values are valid for ISO 4014 and ISO 4017 hex head, ISO 4162 hex socket head, and ISO 4032 hex nuts.

^dHex flange column values are valid for ASME B18.2.3.9M, ISO 4161, or EN 1665 hex flange products.

Fluid Capacities

	Liters	Gallons
Fuel Tank Capacity 5090M/5100M (Standard)	134.0	35.4
Fuel Tank Capacity 5090M/5100M (High Capacity)/5115M/5125M	160.5	42.4
DEF Tank Capacity	12.1	3.2
Engine Crankcase with Filter	13	3.4
Transmission/Hydraulic System	39.5	10.4
Cooling System	22	5.8
MFWD Differential Housing	5.0	1.3
MFWD Wheel Hub (Each)	0.8	0.2

GS25068,00015EC-19-10MAY21

Machine Dimensions

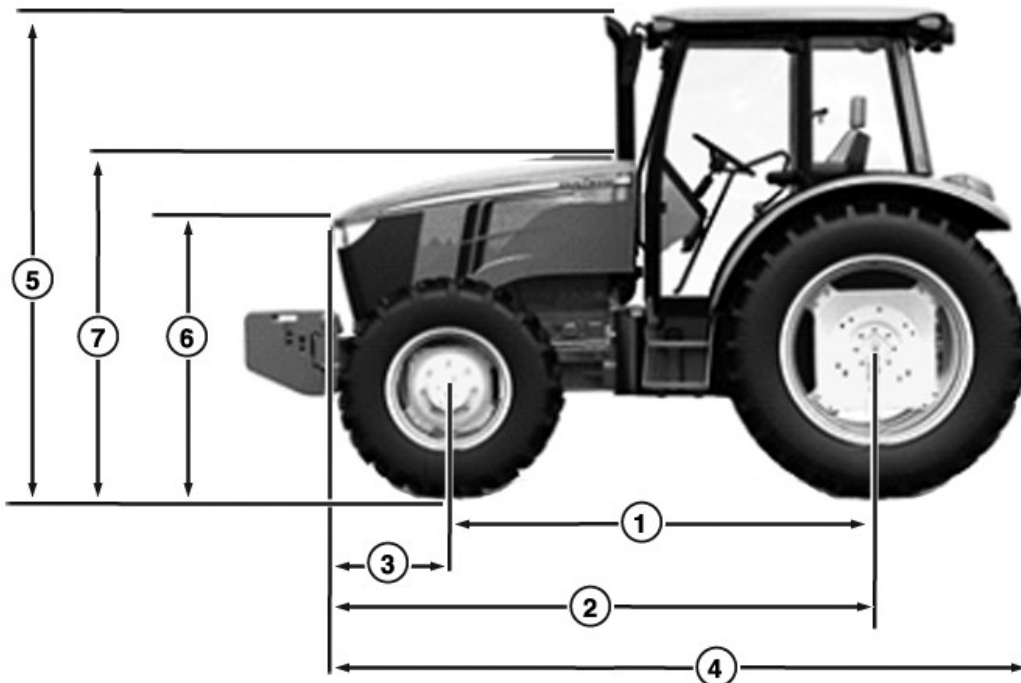

RXA0154429—UN—18NOV16

- 1—Wheelbase
- 2—Hood Length
- 3—Hood in Front of Axle
- 4—Overall Length

- 5—Overall Height
- 6—Front Hood Height
- 7—Rear Hood Height

NOTE: Measurements made with 16.9R34 rear tires.

	Millimeters	Inches
Wheelbase	2350	92.5
Hood Length	2995	117.9
Hood in Front of Axle	645	25.3
Overall Length	3753	147.8
Overall Height	2695	106.1

Specifications

	Millimeters	Inches
Front Hood Height	1420	55.9
Rear Hood Height	1793	70.6

	Millimeters	Inches
5M (with fender extension)	2175	85.6
5M (without fender extension)	1880	74

MP60050,0000A43-19-01MAR21

Machine Weight

NOTE: Machine weight is measured with more than 18.9 L (5 gal) of fuel and all other fluids at full capacity.

Machine weight is approximately shipping weight. Adding or removing options will change the weight. If more accurate weight is desired, weigh on a platform scale.

Base Machine Weight	Kilograms	Pounds
MFWD Cab	4175	9204

GS25068,00015EE-19-15NOV22

Engine and PTO Power

	5090M	5100M	5115M	5125M
Engine Power at 2200 rpm (Factory observed per 97/68/EC ISO industry standard) (± 3 %)	66.2 kW 88.8 hp	73.5 kW 98.6 hp	84.6 kW 113.4 hp	91.9 kW 123.2 hp
PTO Power at 2100 rpm (Factory observed per SAE industry standard) (± 5%)	55.9 kW 75.0 hp	63.4 kW 85.0 hp	74.6 kW 100.0 hp	82.0 kW 110.0 hp

GS25068,00015ED-19-20APR21

Engine Specifications

Type	Diesel
Aspiration	Turbocharged and Aftercooled
Cylinders	In-line 4
Displacement	4.5 L 275 in ³ ,
Fuel Control	Electronic
Low Idle Speed	900 ±10 rpm
Rated Speed	2200 rpm
High Idle Speed	2300 ±50 rpm

HV12280,0000974-19-17FEB21

Specifications

Electrical Specifications

Battery Voltage	12 Volts
Battery Cold Cranking Capacity	950 Amperes
Reserve Capacity	180 Minutes
Alternator Capacity	Cab: 120 Amperes Field Installed Option: 200 Amperes

GS25068,00015EF-19-20APR21

PTO Engine Speeds

PTO Speed	Engine Speed (rpm)
540	2100
540E	1645
1000	2100

GS25068,00015F0-19-20APR21

Hydraulics Specifications

Pump Type	Gear
Steering Pump Displacement	9.50 cc/rev 0.58 in ³ /rev
Implement Pump Displacement	28.0 cc/rev 1.82 in ³ /rev
Steering Pump Flow	24.0 L/min 6.3 gal/min
Implement Pump Flow	73 L/min 19.3 gal/min
Maximum Pressure-Steering	17500-18100 kPa 175-181 bar 2538-2625 psi
Maximum Pressure-Implement	19500-20500 kPa 195-205 bar 2828-2973 psi

GS25068,00015F1-19-20APR21

Rear Hitch Lift Capacities

IMPORTANT: In all applications, pay attention to axle load capacity and tire load capacity.

Cylinder Diameter	Throughout Lift Range Force		Max Lift Force	
	At Hitch Ball	610 mm Behind Lift Point	At Hitch Ball	610 mm Behind Lift Point
75 mm	31.8 kN (7171 lbf) 3247 kg (7158 lb)	31.0 kN (6969 lbf) 3164 kg (6975 lb)	39.4 kN (8857 lbf) 5045 kg (11122 lb)	34.5 kN (7755 lbf) 3523 kg (7766 lb)
80 mm	36.2 kN (8138 lbf) 3700 kg (8157 lb)	34.9 kN (7845 lbf) 3569 kg (7868 lb)	55.6 kN (12499 lbf) 5677 kg (12515 lb)	39.5 kN (8879 lbf) 4029 kg (8882 lb)

GS25068,00015F2-19-17MAY21

Front Hitch Lift Capacities

IMPORTANT: In all applications, pay attention to axle load capacity and tire load capacity.

Throughout Lift Range Force		Max Lift Force	
At Hitch Ball	610 mm Ahead of Lift Point	At Hitch Ball	610 mm Ahead of Lift Point
25.8 kN (5800 lbf) 2627 kg (5791 lb)	18.5 kN (4159 lbf) 1882 kg (4149 lb)	30.2 kN (6789 lbf) 3079 kg (6788 lb)	27.6 kN (6205 lbf) 2814 kg (6203 lb)

GS25068.00015F3-19-20APR21

Drawbar Capacities

Maximum Static Vertical Loads		
Drawbar-Standard	250 mm Extended	1250 kg 2756 lb
	350 mm Extended	1100 kg 2425 lb
	400 mm Extended	1000 kg 2205 lb
Drawbar-Heavy Duty	250 mm Extended	1450 kg 3197 lb
	350 mm Extended	1200 kg 2646 lb

MP60050.0000C79-19-04MAY17

Weight Distribution

MFWD

Implement Attachment	Rear Weight (% of machine weight)	Front Weight (% of machine weight)
Drawbar	65	35
Integral (Hitch)	60	40

HV12280.0000979-19-17FEB21

Permissible Load

IMPORTANT: Always consult your tire manufacturer's information, as permissible load varies per manufacturer, load capacity, inflation pressure, speed-radius index, and travel speed.

Machine Configuration	Max Permissible Weight	Max Front Axle Load	Max Rear Axle Load	Max Payload
MFWD	8000 kg 17637 lb	3000 kg 6614 lb	6000 kg 13228 lb	3325 kg 7330 lb

GS25068.00015F6-19-21APR21

Specifications

Ballast Capacities

Maximum Ballast Weight	5500 kg 12125 lb
Front Base Weight	55 kg 121 lb
Maximum Number of Front Weights	14
Maximum Front Ballast	755 kg 1664 lb
Maximum Number of Rear Weights	Up to 4 pairs of 43 kg (95 lb) or Up to 3 pairs of 48 kg (106 lb)

MP60050.00009F9-19-04MAY17

Sound Level

Max. sound level at operator's ear	Measurement method in accordance with Directive 2009/76/EC
Cab	78 dB (A)

HV12280.000097B-19-17FEB21

Identification Numbers

Record Product Identification Number

Each machine has its own unique Product Identification

Number (PIN). The PIN number is broken down as follows:

1	L	V	5	1	1	5	M	#	#	A	4	0	1	3	7	6
WMC		Build Factory	Machine Series	Engine hp			Machine Family	Check Letter	Calendar Year	Model Year	Operator's Station Identifier	Build Sequence				
Model Number				Serial Number												

WMC: World Manufacturing Code.

Build Factory: represents manufacturing location.

Machine Series: represents machine series.

Engine hp: represents approximate engine horsepower.

Machine Family: represents overall machine configuration.

Check Letter: calculated based on values and positions of the other characters in the PIN.

Calendar Year = represents calendar year of manufacture (2010 = A, 2031 = 1, 2040 = A again).

Model Year = represents number of years manufactured.

Operator's Station = represents style of cab or open operator's station.

Build Sequence = represents the consecutive number of machines built with the same machine series through operator's station identifiers.

Model Number: made up of series, hp, and family; example shown 5115M.

Serial Number: made up of an operator's station identifier and build sequence; example shown 401376.

Product Identification Number _____

DP51502,0000BAB-19-25AUG20

Record Front Axle Serial Number

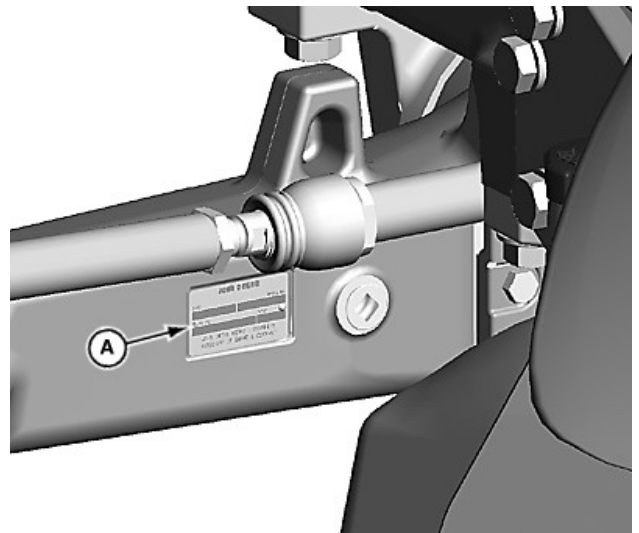

LV18529—UN—30JUL13

The serial number plate is on the rear side of the left-hand axle housing.

Front Axle Serial Number _____

GS25068,0003FBC-19-14FEB18

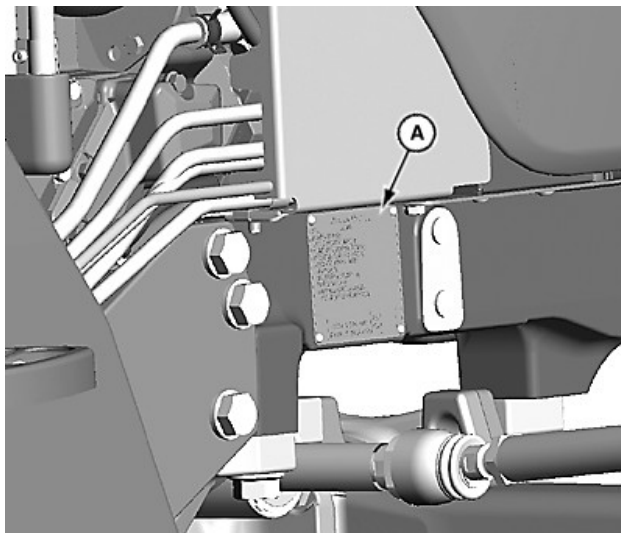

LV18519—UN—30JUL13

Product Identification Number (PIN) plate is on the right front support member of the machine.

Record Engine Serial Number

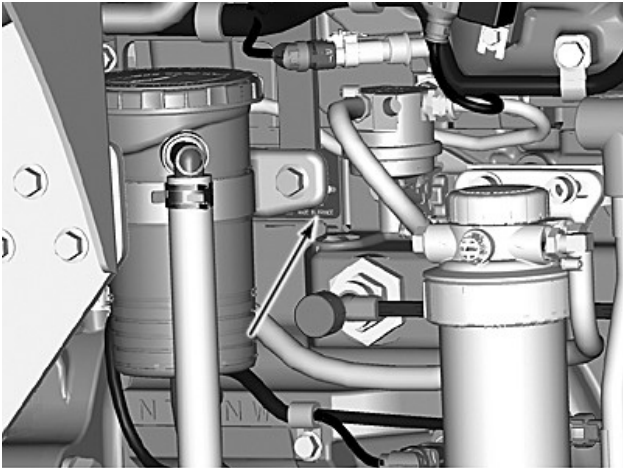

LV14644—UN—12AUG11



LV22864—UN—21AUG14

The serial number is placed in two locations. The plate is on the right-hand side of the engine block, behind the OCV filter bracket. The sticker is on the left-hand side of the engine to the right of the fuel filter.

Engine Serial Number _____

GS25068,00015EB-19-20APR21

Record Transmission Serial Number



PULV000135—UN—22OCT07

The serial number plate is located behind the right-hand hitch lift arm on the differential housing.

Transmission Serial Number _____

DP51502,0002B4B-19-03FEB17

Record Cab Serial Number



RXA0158314—UN—16MAR17

The serial number label is located behind the operator's seat underneath the rear window.

Cab Serial Number _____

GS25068,000547B-19-20SEP18

Keep Proof of Ownership



TS1680—UN—09DEC03

1. Maintain in a secure location an up-to-date inventory of all product and component serial numbers.
2. Regularly verify that identification plates have not been removed. Report any evidence of tampering to law enforcement agencies and order duplicate plates.
3. Other steps you can take:
 - Mark your machine with your own numbering system
 - Take color photographs from several angles of each machine

DX,SECURE1-19-18NOV03

Certification and Warranty

Cab ROPS Certificate

JOHN DEERE	
Component Serial Number	
PXCG094-----	Model: PXCG094
Approved for use on:	
5075M, 5090M, 5100M, 5100MH, 5115M	
OECD APPROVAL NUMBER(S):	7/S/0 415
ROPS tested in accordance with requirements:	
SAE J2194 AUG02 AS1636.1 CSA B3521 - 1999	
MADE IN MEXICO DEERE & COMPANY, MOLINE, ILLINOIS, USA	
WARNING: ADDITIONS, ALTERATIONS, CRACKING, DAMAGE OR CORROSION TO THIS STRUCTURE MAY ADVERSELY AFFECT ITS PERFORMANCE	

RXA0159126—UN—04MAY17
ROPS Certification Label



RXA0158314—UN—16MAR17
Cab Wall Behind Seat

ROPS tested in accordance with requirements:

SAE J2194 AUG02 AS1636.1

CSA B352.1 - 1999

MADE IN MEXICO

DEERE & COMPANY, MOLINE, ILLINOIS USA

**WARNING: ADDITIONS, ALTERATIONS, CRACKING,
DAMAGE or CORROSION TO THIS STRUCTURE**

MAY ADVERSELY AFFECT ITS PERFORMANCE

MP60050,0000A46-19-01MAR21

Limited Battery Warranty

NOTE: Applicable in North America only. For complete machine warranty, reference a copy of the John Deere warranty statement. Contact your John Deere dealer to obtain a copy.

To Secure Warranty Service

The purchaser must request warranty service from a John Deere dealer authorized to sell John Deere batteries, and present the battery to the dealer with the top cover plate codes intact.

Replacement

Any new battery which becomes unserviceable (not merely discharged) due to defects in material or workmanship will be eligible for warranty consideration.

This Warranty Does Not Cover

Breakage of the container, cover, or terminals.

Depreciation or damage caused by lack of reasonable and necessary maintenance or by improper maintenance.

Transportation, mailing, or service call charges for warranty service.

Limitation of Implied Warranties and Purchaser's Remedies

To the extent permitted by law, neither John Deere nor any company affiliated with it makes any warranties, representations or promises as to the quality, performance or freedom from defect of the products covered by this warranty. IMPLIED WARRANTIES OF MERCHANTABILITY AND FITNESS FOR A PARTICULAR PURPOSE, TO THE EXTENT APPLICABLE, SHALL BE LIMITED IN DURATION TO THE APPLICABLE ADJUSTMENT PERIOD SET FORTH HERE. THE PURCHASER'S ONLY REMEDIES IN CONNECTION WITH THE BREACH OR PERFORMANCE OF ANY WARRANTY ON JOHN DEERE BATTERIES ARE THOSE SET FORTH HERE. IN NO EVENT WILL THE DEALER, JOHN DEERE OR ANY COMPANY AFFILIATED WITH JOHN DEERE BE LIABLE FOR INCIDENTAL OR CONSEQUENTIAL DAMAGES. (Note: Some states do not allow limitations on how long an implied warranty lasts or the exclusion or limitation of incidental or consequential damages. So these limitations and exclusions may not apply to you.) This warranty gives you specific legal rights, and you may also have some rights which vary from state to state.

No Dealer Warranty

The selling dealer makes no warranty of its own and the

dealer has no authority to make any representation or promise on behalf of John Deere, or to modify the terms or limitations of this warranty in any way.

DX.BATWAR,NA-19-06AUG21

Emissions Control System Certification Label

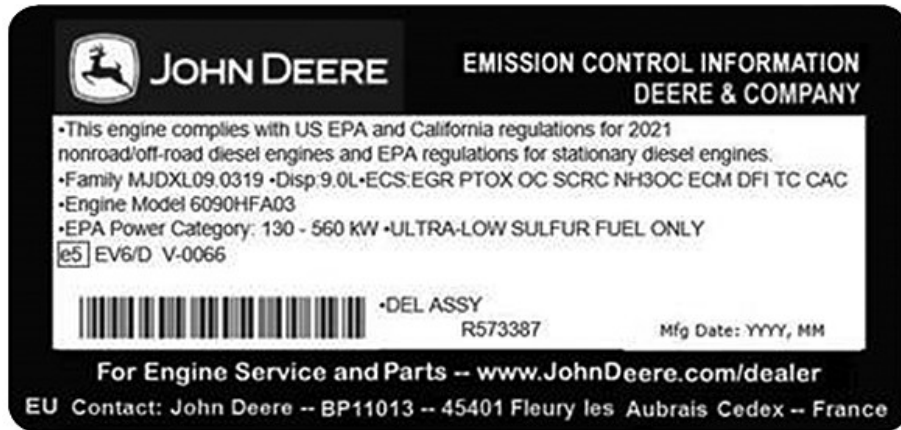

Engine Emissions Label

RG33429—UN—04FEB21

⚠ CAUTION: Statutes providing severe penalties for tampering with emissions controls may apply to the user or dealer.

The emissions warranty applies to those engines marketed by John Deere that have been certified by the United States Environmental Protection Agency (EPA) and/or California Air Resources Board (CARB); and used in the United States and Canada in Non-road equipment. The presence of an emissions label like the one shown signifies that the engine has been certified with the EPA and/or CARB. The EPA and CARB warranties only apply to new engines having the certification label affixed to the engine and sold as stated above in the geographic areas. The presence of an EU number signifies that the engine has been certified with the European Union countries per Regulation (EU) 2016/1628 and supplementing legislation. The EPA and/or CARB emissions warranties do not apply to the EU countries.

The emissions label has applicable US EPA and/or CARB regulatory year. The regulatory year determines which warranty statement is applicable to engine. See “EPA Non-road Emissions Control Warranty Statement—Compression Ignition” and “CARB Non-road Emissions Control Warranty Statement—Compression Ignition”. For additional regulatory year warranty statements, see www.JohnDeere.com or contact the nearest John Deere service dealer for assistance.

Emission Control System(s) Laws

The U.S. EPA and California ARB prohibit the removal or rendering inoperative of any device or element of design installed on or in engines/equipment in compliance with applicable emission regulations prior to or after the sale and delivery of the engines/equipment to the ultimate purchaser.

DX,EMISSIONS,LABEL-19-05FEB21

Carbon Dioxide Emissions (CO₂)

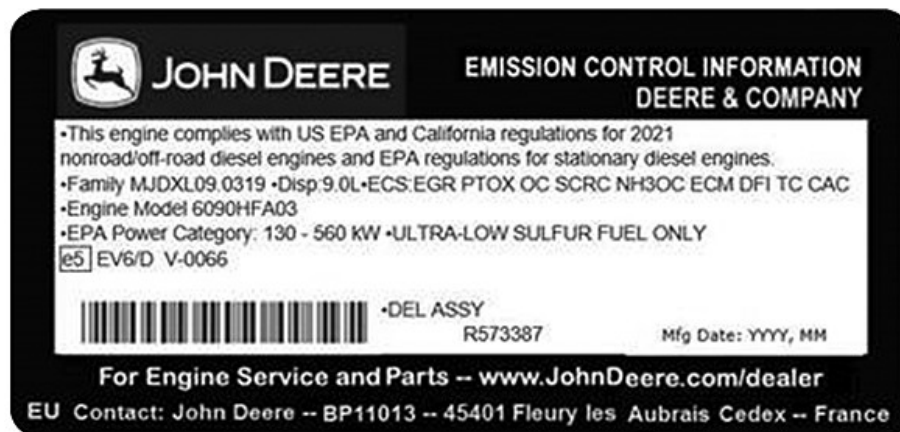

SAMPLE - Engine Emissions Label

RG33429—UN—04FEB21

To identify the carbon dioxide (CO₂) output, locate the engine emissions label. Find the appropriate family on the emissions label and reference the chart.

NOTE: The first letter of the family number is not utilized for family identification on the chart.

Emissions Label Family	CO ₂ Result
_JDXL02.9323	952 g/kW-hr
_JDXL02.9327	784 g/kW-hr
_JDXL04.5337	819 g/kW-hr
_JDXL04.5338	682 g/kW-hr
_JDXL04.5304	1004 g/kW-hr
_JDXN04.5174	792 g/kW-hr
_JDXL06.8324	720 g/kW-hr
_JDXL06.8328	683 g/kW-hr
_JDXL06.8336	701 g/kW-hr
_JDXN06.8175	771 g/kW-hr
_JDXL09.0319	646 g/kW-hr

Emissions Label Family	CO ₂ Result
_JDXL09.0325	695 g/kW-hr
_JDXL09.0329	657 g/kW-hr
_JDXL09.0333	650 g/kW-hr
_JDXL13.5326	684 g/kW-hr
_JDXL13.6320	651 g/kW-hr
_JDXL13.5340	632 g/kW-hr
_JDXL18.0341	683 g/kW-hr
_JDXL18.0342	687 g/kW-hr
F28	870 g/kW-hr
F32	710 g/kW-hr
F33	677 g/kW-hr

This CO₂ measurement results from testing over a fixed test cycle under laboratory conditions a(n) (parent) engine representative of the engine type (engine family) and shall not imply or express any guarantee of the performance of a particular engine.

DX.EMISSIONS.CO2-19-23JUN23

CARB Non-road Emissions Control Warranty Statement—Compression Ignition

Emissions Control Warranty Statement 2019 through 2021



JOHN DEERE

DXLOGOV1—UN—28APR09

CALIFORNIA EMISSIONS CONTROL WARRANTY STATEMENT YOUR WARRANTY RIGHTS AND OBLIGATIONS

To determine if the John Deere engine qualifies for the additional warranties set forth below, look for the "Emission Control Information" label located on the engine. If the engine is operated in the United States or Canada and the engine label states: "This engine complies with US EPA regulations for nonroad and stationary diesel engines", or "This engine complies with US EPA regulations for stationary emergency diesel engines", refer to the "U.S. and Canada Emission Control Warranty Statement." If the engine is operated in California, and the engine label states: "This engine complies with US EPA and CARB regulations for nonroad diesel engines" also refer to the "California Emissions Control Warranty

Statement.”

Warranties stated on this certificate refer only to emissions-related parts and components of your engine. The complete engine warranty, less emission-related parts and components, is provided separately. If you have any questions about your warranty rights and responsibilities, you should contact John Deere at 1-319-292-5400.

CALIFORNIA EMISSIONS CONTROL WARRANTY STATEMENT:

The California Air Resources Board (CARB) is pleased to explain the emission-control system warranty on 2019 through 2021 off-road diesel engines. In California, new off-road engines must be designed, built and equipped to meet the State’s stringent anti-smog standards. John Deere must warrant the emission control system on your engine for the periods of time listed below provided there has been no abuse, neglect or improper maintenance of your engine.

Your emission control system may include parts such as the fuel injection system and the air induction system. Also included may be hoses, belts, connectors and other emission-related assemblies.

John Deere warrants to the ultimate purchaser and each subsequent purchaser that this off-road diesel engine was designed, built, and equipped so as to conform at the time of sale with all applicable regulations adopted by CARB and is free from defects in materials and workmanship which would cause the failure of a warranted part to be identical in all material respects to the part as described in John Deere's application for certification for a period of five years from the date the engine is delivered to an ultimate purchaser or 3,000 hours of operation, whichever occurs first for all engines rated at 19 kW and greater. In the absence of a device to measure hours of use, the engine shall be warranted for a period of five years.

EMISSIONS WARRANTY EXCLUSIONS:

John Deere may deny warranty claims for failures caused by the use of an add-on or modified part which has not been exempted by the CARB. A modified part is an aftermarket part intended to replace an original emission-related part which is not functionally identical in all respects and which in any way affects emissions. An add-on part is any aftermarket part which is not a modified part or a replacement part.

In no event will John Deere, any authorized engine distributor, dealer, or repair facility, or any company affiliated with John Deere be liable for incidental or consequential damage.

JOHN DEERE'S WARRANTY RESPONSIBILITY:

Where a warrantable condition exists, John Deere will repair or replace, as it elects, your off-road diesel engine at no cost to you, including diagnosis, parts or labor. Warranty coverage is subject to the limitations and exclusions set forth herein. The off-road diesel engine is warranted for a period of five years from the date the engine is delivered to an ultimate purchaser or 3,000 hours of operation, whichever occurs first. The following are emissions-related parts:

- Air Induction System
- Intake manifold
 - Turbocharger
 - Charge air cooler

- Fuel Metering system
- Fuel injection system

- Exhaust Gas Recirculation
- EGR valve

- Catalyst or Thermal Reactor Systems
- Catalytic converter
 - Exhaust manifold

Emission control labels

- Particulate Controls
- Any device used to capture particulate emissions
 - Any device used in the regeneration of the capturing system
 - Enclosures and manifolding
 - Smoke Puff Limiters

- Positive Crankcase Ventilation (PCV) System
- PCV valve
 - Oil filler cap

- Advanced Oxides of Nitrogen (NOx) Controls
- NOx absorbers and catalysts

SCR systems and urea containers/dispensing systems

- Miscellaneous Items used in Above Systems
- Electronic control units, sensors, actuators, wiring harnesses, hoses, connectors, clamps, fittings, gasket, mounting hardware

Certification and Warranty

Any warranted emissions-related part scheduled for replacement as required maintenance is warranted by John Deere for the period of time prior to the first scheduled replacement point for the part. Any warranted emissions-related part not scheduled for replacement as required maintenance or scheduled only for regular inspection is warranted by John Deere for the stated warranty period.

OWNER'S WARRANTY RESPONSIBILITIES:

As the off-road diesel engine owner you are responsible for the performance of the required maintenance listed in your Operator's Manual. John Deere recommends that the owner retain all receipts covering maintenance on the off-road diesel engine, but John Deere cannot deny warranty solely for the lack of receipts or for the owner's failure to ensure the performance of all scheduled maintenance. However, as the off-road diesel engine owner, you should be aware that John Deere may deny you warranty coverage if your off-road diesel engine or a part has failed due to abuse, neglect, improper maintenance or unapproved modifications.

The off-road diesel engine is designed to operate on diesel fuel as specified in the Fuels, Lubricants and Coolants section in the Operators Manual. Use of any other fuel may result in the engine no longer operating in compliance with applicable emissions requirements.

The owner is responsible for initiating the warranty process, and should present the machine to the nearest authorized John Deere dealer as soon as a problem is suspected. The warranty repairs should be completed by the authorized John Deere dealer as quickly as possible.

Emissions regulations require the customer to bring the unit to an authorized servicing dealer when warranty service is required. As a result, John Deere is NOT liable for travel or mileage on emissions warranty service calls.

Emission_CI_CARB (01Feb17)

Emissions Control Warranty Statement 2019 through 2021

DXLOGOV1 —UN—28APR09



JOHN DEERE

CALIFORNIA EMISSIONS CONTROL WARRANTY STATEMENT YOUR WARRANTY RIGHTS AND OBLIGATIONS

To determine if the John Deere engine qualifies for the additional warranties set forth below, look for the “Emission Control Information” label located on the engine. If the engine is operated in the United States or Canada and the engine label states: “This engine complies with US EPA regulations for nonroad and stationary diesel engines”, or “This engine complies with US EPA regulations for stationary emergency diesel engines”, refer to the “U.S. and Canada Emission Control Warranty Statement.” If the engine is operated in California, and the engine label states: “This engine complies with US EPA and CARB regulations for nonroad diesel engines” also refer to the “California Emissions Control Warranty Statement.”

Warranties stated on this certificate refer only to emissions-related parts and components of your engine. The complete engine warranty, less emission-related parts and components, is provided separately. If you have any questions about your warranty rights and responsibilities, you should contact John Deere at 1-319-292-5400.

CALIFORNIA EMISSIONS CONTROL WARRANTY STATEMENT:

The California Air Resources Board (CARB) is pleased to explain the emission-control system warranty on 2019 through 2021 off-road diesel engines. In California, new off-road engines must be designed, built and equipped to meet the State’s stringent anti-smog standards. John Deere must warrant the emission control system on your engine for the periods of time listed below provided there has been no abuse, neglect or improper maintenance of your engine.

Your emission control system may include parts such as the fuel injection system and the air induction system. Also included may be hoses, belts, connectors and other emission-related assemblies.

John Deere warrants to the ultimate purchaser and each subsequent purchaser that this off-road diesel engine was designed, built, and equipped so as to conform at the time of sale with all applicable regulations adopted by CARB and is free from defects in materials and workmanship which would cause the failure of a warranted part to be identical in all material respects to the part as described in John Deere’s application for certification for a period of five years from the date the engine is delivered to an ultimate purchaser or 3,000 hours of operation, whichever occurs first for all engines rated at 19 kW and greater. In the absence of a device to measure hours of use, the engine shall be warranted for a period of five years.

EMISSIONS WARRANTY EXCLUSIONS:

John Deere may deny warranty claims for failures caused by the use of an add-on or modified part which has not been exempted by the CARB. A modified part is an aftermarket part intended to replace an original emission-related part which is not functionally identical in all respects and which in any way affects emissions. An add-on part is any aftermarket part which is not a modified part or a replacement part.

In no event will John Deere, any authorized engine distributor, dealer, or repair facility, or any company affiliated with John Deere be liable for incidental or consequential damage.

RG29280—UN—02FEB17

JOHN DEERE'S WARRANTY RESPONSIBILITY:

Where a warrantable condition exists, John Deere will repair or replace, as it elects, your off-road diesel engine at no cost to you, including diagnosis, parts or labor. Warranty coverage is subject to the limitations and exclusions set forth herein. The off-road diesel engine is warranted for a period of five years from the date the engine is delivered to an ultimate purchaser or 3,000 hours of operation, whichever occurs first. The following are emissions-related parts:

Air Induction System	Emission control labels	Advanced Oxides of Nitrogen (NOx) Controls
<ul style="list-style-type: none">• Intake manifold• Turbocharger• Charge air cooler	Particulate Controls	<ul style="list-style-type: none">• NOx absorbers and catalysts
Fuel Metering system	<ul style="list-style-type: none">• Any device used to capture particulate emissions• Any device used in the regeneration of the capturing system• Enclosures and manifolding• Smoke Puff Limiters	SCR systems and urea containers/dispensing systems
<ul style="list-style-type: none">• Fuel injection system	Positive Crankcase Ventilation (PCV) System	Miscellaneous Items used in Above Systems
Exhaust Gas Recirculation	<ul style="list-style-type: none">• PCV valve• Oil filler cap	<ul style="list-style-type: none">• Electronic control units, sensors, actuators, wiring harnesses, hoses, connectors, clamps, fittings, gasket, mounting hardware
<ul style="list-style-type: none">• EGR valve		
Catalyst or Thermal Reactor Systems		
<ul style="list-style-type: none">• Catalytic converter• Exhaust manifold		

Any warranted emissions-related part scheduled for replacement as required maintenance is warranted by John Deere for the period of time prior to the first scheduled replacement point for the part. Any warranted emissions-related part not scheduled for replacement as required maintenance or scheduled only for regular inspection is warranted by John Deere for the stated warranty period.

OWNER'S WARRANTY RESPONSIBILITIES:

As the off-road diesel engine owner you are responsible for the performance of the required maintenance listed in your Operator's Manual. John Deere recommends that the owner retain all receipts covering maintenance on the off-road diesel engine, but John Deere cannot deny warranty solely for the lack of receipts or for the owner's failure to ensure the performance of all scheduled maintenance. However, as the off-road diesel engine owner, you should be aware that John Deere may deny you warranty coverage if your off-road diesel engine or a part has failed due to abuse, neglect, improper maintenance or unapproved modifications.

The off-road diesel engine is designed to operate on diesel fuel as specified in the Fuels, Lubricants and Coolants section in the Operators Manual. Use of any other fuel may result in the engine no longer operating in compliance with applicable emissions requirements.

The owner is responsible for initiating the warranty process, and should present the machine to the nearest authorized John Deere dealer as soon as a problem is suspected. The warranty repairs should be completed by the authorized John Deere dealer as quickly as possible.

Emissions regulations require the customer to bring the unit to an authorized servicing dealer when warranty service is required. As a result, John Deere is NOT liable for travel or mileage on emissions warranty service calls.

Emission_CI_CARB (01Feb17)

RG29281—UN—27FEB17

Emissions Control Warranty Statement 2022 through 2024



JOHN DEERE

DXLOGOV1—UN—28APR09

**CALIFORNIA EMISSIONS CONTROL WARRANTY STATEMENT
YOUR WARRANTY RIGHTS AND OBLIGATIONS**

To determine if the John Deere engine qualifies for the additional warranties set forth below, look for the "Emission Control Information" label located on the engine. If the engine is operated in the United States or Canada and the engine label states: "This engine complies with US EPA regulations for nonroad and stationary diesel engines", or "This engine complies with US EPA regulations for stationary emergency diesel engines", refer to the "U.S. and Canada Emission Control Warranty Statement." If the engine is operated in California, and the engine label states: "This engine complies with US EPA and California regulations for nonroad/off-road diesel engines" also refer to the "California Emissions Control Warranty Statement."

Warranties stated on this certificate refer only to emissions-related parts and components of your engine. The complete engine warranty, less emission-related parts and components, is provided separately. If you have any questions about your warranty rights and responsibilities, you

Certification and Warranty

should contact John Deere at 1-319-292-5400.

CALIFORNIA EMISSIONS CONTROL WARRANTY STATEMENT:

The California Air Resources Board (CARB) is pleased to explain the emission-control system warranty on 2022 through 2024 off-road diesel engines. In California, new off-road engines must be designed, built and equipped to meet the State's stringent anti-smog standards. John Deere must warrant the emission control system on your engine for the periods of time listed below provided there has been no abuse, neglect or improper maintenance of your engine.

Your emission control system may include parts such as the fuel injection system and the air induction system. Also included may be hoses, belts, connectors and other emission-related assemblies.

John Deere warrants to the ultimate purchaser and each subsequent purchaser that this off-road diesel engine was designed, built, and equipped so as to conform at the time of sale with all applicable regulations adopted by CARB. John Deere warrants that this engine is free from defects in materials and workmanship which would cause the failure of emissions warranted parts to be identical in all material respects to the part as described in John Deere's application for certification for a period of five years from the date the engine is delivered to an ultimate purchaser or 3,000 hours of operation, whichever occurs first. This applies to all engines rated at 19 kW and greater. In the absence of a device to measure hours of use, the engine shall be warranted for a period of five years.

EMISSIONS WARRANTY EXCLUSIONS:

John Deere may deny warranty claims for failures caused by the use of an add-on or modified part which has not been exempted by the CARB. A modified part is an aftermarket part intended to replace an original emission-related part which is not functionally identical in all respects and which in any way affects emissions. An add-on part is any aftermarket part which is not a modified part or a replacement part.

In no event will John Deere, any authorized engine distributor, dealer, or repair facility, or any company affiliated with John Deere be liable for incidental or consequential damage.

JOHN DEERE'S WARRANTY RESPONSIBILITY:

Where a warrantable condition exists, John Deere will repair or replace, as it elects, your off-road diesel engine at no cost to you, including diagnosis, parts or labor. Warranty coverage is subject to the limitations and exclusions set forth herein. The off-road diesel engine is warranted for a period of five years from the date the engine is delivered to an ultimate purchaser or 3,000 hours of operation, whichever occurs first. The following are emissions-related parts:

Air Induction System

- Intake manifold
- Turbocharger
- Charge air cooler

Fuel Metering system

- Fuel injection system

Exhaust Gas Recirculation

- EGR valve

Catalyst or Thermal Reactor Systems

- Catalytic converter
- Exhaust manifold

Emission control labels

Particulate Controls

- Any device used to capture particulate emissions
- Any device used in the regeneration of the capturing system
- Enclosures and manifolding
- Smoke Puff Limiters

Positive Crankcase Ventilation (PCV) System

- PCV valve
- Oil filler cap

Advanced Oxides of Nitrogen (NOx) Controls

- NOx absorbers and catalysts

SCR systems and urea containers/dispensing systems

Miscellaneous Items used in Above Systems

- Electronic control units, sensors, actuators, wiring harnesses, hoses, connectors, clamps, fittings, gasket, mounting hardware

Certification and Warranty

Any warranted emissions-related part scheduled for replacement as required maintenance is warranted by John Deere for the period of time prior to the first scheduled replacement point for the part. Any warranted emissions-related part not scheduled for replacement as required maintenance or scheduled only for regular inspection is warranted by John Deere for the stated warranty period.

OWNER'S WARRANTY RESPONSIBILITIES:

As the off-road diesel engine owner you are responsible for the performance of the required maintenance listed in your Operator's Manual. John Deere recommends that the owner retain all receipts covering maintenance on the off-road diesel engine, but John Deere cannot deny warranty solely for the lack of receipts or for the owner's failure to ensure the performance of all scheduled maintenance. However, as the off-road diesel engine owner, you should be aware that John Deere may deny you warranty coverage if your off-road diesel engine or a part has failed due to abuse, neglect, improper maintenance or unapproved modifications.

The off-road diesel engine is designed to operate on diesel fuel as specified in the Fuels, Lubricants and Coolants section in the Operators Manual. Use of any other fuel may result in the engine no longer operating in compliance with applicable emissions requirements.

The owner is responsible for initiating the warranty process, and should present the machine to the nearest authorized John Deere dealer as soon as a problem is suspected. The warranty repairs should be completed by the authorized John Deere dealer as quickly as possible.

Emissions regulations require the customer to bring the unit to an authorized servicing dealer when warranty service is required. As a result, John Deere is NOT liable for travel or mileage on emissions warranty service calls.

Emission_CI_CARB (14Apr20)

Emissions Control Warranty Statement 2022 through 2024

DXLOGOV1 —UN—28APR09



JOHN DEERE

CALIFORNIA EMISSIONS CONTROL WARRANTY STATEMENT YOUR WARRANTY RIGHTS AND OBLIGATIONS

To determine if the John Deere engine qualifies for the additional warranties set forth below, look for the "Emission Control Information" label located on the engine. If the engine is operated in the United States or Canada and the engine label states: "This engine complies with US EPA regulations for nonroad and stationary diesel engines", or "This engine complies with US EPA regulations for stationary emergency diesel engines", refer to the "U.S. and Canada Emission Control Warranty Statement." If the engine is operated in California, and the engine label states: "This engine complies with US EPA and California regulations for nonroad/off-road diesel engines" also refer to the "California Emissions Control Warranty Statement."

Warranties stated on this certificate refer only to emissions-related parts and components of your engine. The complete engine warranty, less emission-related parts and components, is provided separately. If you have any questions about your warranty rights and responsibilities, you should contact John Deere at 1-319-292-5400.

CALIFORNIA EMISSIONS CONTROL WARRANTY STATEMENT:

The California Air Resources Board (CARB) is pleased to explain the emission-control system warranty on 2022 through 2024 off-road diesel engines. In California, new off-road engines must be designed, built and equipped to meet the State's stringent anti-smog standards. John Deere must warrant the emission control system on your engine for the periods of time listed below provided there has been no abuse, neglect or improper maintenance of your engine.

Your emission control system may include parts such as the fuel injection system and the air induction system. Also included may be hoses, belts, connectors and other emission-related assemblies.

John Deere warrants to the ultimate purchaser and each subsequent purchaser that this off-road diesel engine was designed, built, and equipped so as to conform at the time of sale with all applicable regulations adopted by CARB. John Deere warrants that this engine is free from defects in materials and workmanship which would cause the failure of emissions warranted parts to be identical in all material respects to the part as described in John Deere's application for certification for a period of five years from the date the engine is delivered to an ultimate purchaser or 3,000 hours of operation, whichever occurs first. This applies to all engines rated at 19 kW and greater. In the absence of a device to measure hours of use, the engine shall be warranted for a period of five years.

EMISSIONS WARRANTY EXCLUSIONS:

John Deere may deny warranty claims for failures caused by the use of an add-on or modified part which has not been exempted by the CARB. A modified part is an aftermarket part intended to replace an original emission-related part which is not functionally identical in all respects and which in any way affects emissions. An add-on part is any aftermarket part which is not a modified part or a replacement part.

In no event will John Deere, any authorized engine distributor, dealer, or repair facility, or any company affiliated with John Deere be liable for incidental or consequential damage.

RG32758—UN—19AUG20

JOHN DEERE'S WARRANTY RESPONSIBILITY:

Where a warrantable condition exists, John Deere will repair or replace, as it elects, your off-road diesel engine at no cost to you, including diagnosis, parts or labor. Warranty coverage is subject to the limitations and exclusions set forth herein. The off-road diesel engine is warranted for a period of five years from the date the engine is delivered to an ultimate purchaser or 3,000 hours of operation, whichever occurs first. The following are emissions-related parts:

<p>Air Induction System</p> <ul style="list-style-type: none"> • Intake manifold • Turbocharger • Charge air cooler <p>Fuel Metering system</p> <ul style="list-style-type: none"> • Fuel injection system <p>Exhaust Gas Recirculation</p> <ul style="list-style-type: none"> • EGR valve <p>Catalyst or Thermal Reactor Systems</p> <ul style="list-style-type: none"> • Catalytic converter • Exhaust manifold 	<p>Emission control labels</p> <p>Particulate Controls</p> <ul style="list-style-type: none"> • Any device used to capture particulate emissions • Any device used in the regeneration of the capturing system • Enclosures and manifolding • Smoke Puff Limiters <p>Positive Crankcase Ventilation (PCV) System</p> <ul style="list-style-type: none"> • PCV valve • Oil filler cap 	<p>Advanced Oxides of Nitrogen (NOx) Controls</p> <ul style="list-style-type: none"> • NOx absorbers and catalysts <p>SCR systems and urea containers/dispensing systems</p> <p>Miscellaneous Items used in Above Systems</p> <ul style="list-style-type: none"> • Electronic control units, sensors, actuators, wiring harnesses, hoses, connectors, clamps, fittings, gasket, mounting hardware
--	---	--

Any warranted emissions-related part scheduled for replacement as required maintenance is warranted by John Deere for the period of time prior to the first scheduled replacement point for the part. Any warranted emissions-related part not scheduled for replacement as required maintenance or scheduled only for regular inspection is warranted by John Deere for the stated warranty period.

OWNER'S WARRANTY RESPONSIBILITIES:

As the off-road diesel engine owner you are responsible for the performance of the required maintenance listed in your Operator's Manual. John Deere recommends that the owner retain all receipts covering maintenance on the off-road diesel engine, but John Deere cannot deny warranty solely for the lack of receipts or for the owner's failure to ensure the performance of all scheduled maintenance. However, as the off-road diesel engine owner, you should be aware that John Deere may deny you warranty coverage if your off-road diesel engine or a part has failed due to abuse, neglect, improper maintenance or unapproved modifications.

The off-road diesel engine is designed to operate on diesel fuel as specified in the Fuels, Lubricants and Coolants section in the Operators Manual. Use of any other fuel may result in the engine no longer operating in compliance with applicable emissions requirements.

The owner is responsible for initiating the warranty process, and should present the machine to the nearest authorized John Deere dealer as soon as a problem is suspected. The warranty repairs should be completed by the authorized John Deere dealer as quickly as possible.

Emissions regulations require the customer to bring the unit to an authorized servicing dealer when warranty service is required. As a result, John Deere is NOT liable for travel or mileage on emissions warranty service calls.

Emission_CI_CARB (14Apr20)

RG32759—UN—19AUG20
DX,EMISSIONS,CARB-19-26AUG20

EPA Non-road Emissions Control Warranty Statement—Compression Ignition



JOHN DEERE

DXLOGOV1—UN—28APR09

**U.S. AND CANADA EMISSION CONTROL WARRANTY STATEMENT
YOUR WARRANTY RIGHTS AND OBLIGATIONS**

To determine if the John Deere engine qualifies for the additional warranties set forth below, look for the "Emissions Control Information" label located on the engine. If the engine is operated in the United States or Canada and the Emissions Control information label states: "This engine complies with US EPA regulations for nonroad and stationary diesel engines", or "This engine conforms to US EPA nonroad compression-ignition regulations", refer to the "U.S. and Canada Emission Control Warranty Statement." If the engine is operated in California, and the label states: "This engine complies with US EPA and CARB regulations for nonroad diesel engines", or "This engine conforms to US EPA and California nonroad compression-ignition emission regulations", also refer to the "California Emission Control Warranty Statement."

Warranties stated on this certificate refer only to emissions-related parts and components of your engine. The complete engine warranty, less emissions-related parts and components, is provided separately. If you have any questions about your warranty rights and responsibilities, you

should contact John Deere at 1-319-292-5400.

JOHN DEERE'S WARRANTY RESPONSIBILITY

John Deere warrants to the ultimate purchaser and each subsequent purchaser that this off-road diesel engine including all parts of its emission-control system was designed, built and equipped so as to conform at the time of the sale with Section 213 of the Clean Air Act and is free from defects in materials and workmanship which would cause the engine to fail to conform with applicable US EPA regulations for a period of five years from the date the engine is placed into service or 3,000 hours of operation, whichever first occurs.

Where a warrantable condition exists, John Deere will repair or replace, as it elects, any part or component with a defect in materials or workmanship that would increase the engine's emissions of any regulated pollutant within the stated warranty period at no cost to you, including expenses related to diagnosing and repairing or replacing emission-related parts. Warranty coverage is subject to the limitations and exclusions set forth herein. Emission-related components include engine parts developed to control emissions related to the following:

Air-Induction System	Aftertreatment Devices
Fuel System	Crankcase Ventilation Valves
Ignition System	Sensors
Exhaust Gas Recirculation Systems	Engine Electronic Control Units

EMISSION WARRANTY EXCLUSIONS

John Deere may deny warranty claims for malfunctions or failures caused by:

- Non-performance of maintenance requirements listed in the Operator's Manual
- The use of the engine/equipment in a manner for which it was not designed
- Abuse, neglect, improper maintenance or unapproved modifications or alterations
- Accidents for which it does not have responsibility or by acts of God

The off-road diesel engine is designed to operate on diesel fuel as specified in the Fuels, Lubricants and Coolants section in the Operators Manual. Use of any other fuel can harm the emissions control system of the engine/equipment and is not approved for use.

To the extent permitted by law John Deere is not liable for damage to other engine components caused by a failure of an emission-related part, unless otherwise covered by standard warranty.

THIS WARRANTY IS EXPRESSLY IN LIEU OF ANY OTHER WARRANTIES, EXPRESS OR IMPLIED, INCLUDING ANY WARRANTY OF MERCHANTABILITY OR FITNESS FOR A PARTICULAR PURPOSE. REMEDIES UNDER THIS WARRANTY ARE LIMITED TO THE PROVISIONS OF MATERIAL AND SERVICES AS SPECIFIED HEREIN. WHERE PERMITTED BY LAW, NEITHER JOHN DEERE NOR ANY AUTHORIZED JOHN DEERE ENGINE DISTRIBUTOR, DEALER, OR REPAIR FACILITY OR ANY COMPANY AFFILIATED WITH JOHN DEERE WILL BE LIABLE FOR INCIDENTAL OR CONSEQUENTIAL DAMAGES.

Emission_CI_EPA (18Dec09)



JOHN DEERE

**U.S. AND CANADA EMISSION CONTROL WARRANTY STATEMENT
YOUR WARRANTY RIGHTS AND OBLIGATIONS**

To determine if the John Deere engine qualifies for the additional warranties set forth below, look for the "Emissions Control Information" label located on the engine. If the engine is operated in the United States or Canada and the Emissions Control information label states: "This engine complies with US EPA regulations for nonroad and stationary diesel engines", or "This engine conforms to US EPA nonroad compression-ignition regulations", refer to the "U.S. and Canada Emission Control Warranty Statement." If the engine is operated in California, and the label states: "This engine complies with US EPA and CARB regulations for nonroad diesel engines", or "This engine conforms to US EPA and California nonroad compression-ignition emission regulations", also refer to the "California Emission Control Warranty Statement."

Warranties stated on this certificate refer only to emissions-related parts and components of your engine. The complete engine warranty, less emissions-related parts and components, is provided separately. If you have any questions about your warranty rights and responsibilities, you should contact John Deere at 1-319-292-5400.

JOHN DEERE'S WARRANTY RESPONSIBILITY

John Deere warrants to the ultimate purchaser and each subsequent purchaser that this off-road diesel engine including all parts of its emission-control system was designed, built and equipped so as to conform at the time of the sale with Section 213 of the Clean Air Act and is free from defects in materials and workmanship which would cause the engine to fail to conform with applicable US EPA regulations for a period of five years from the date the engine is placed into service or 3,000 hours of operation, whichever first occurs.

Where a warrantable condition exists, John Deere will repair or replace, as it elects, any part or component with a defect in materials or workmanship that would increase the engine's emissions of any regulated pollutant within the stated warranty period at no cost to you, including expenses related to diagnosing and repairing or replacing emission-related parts. Warranty coverage is subject to the limitations and exclusions set forth herein. Emission-related components include engine parts developed to control emissions related to the following:

Air-Induction System	Aftertreatment Devices
Fuel System	Crankcase Ventilation Valves
Ignition System	Sensors
Exhaust Gas Recirculation Systems	Engine Electronic Control Units

EMISSION WARRANTY EXCLUSIONS

John Deere may deny warranty claims for malfunctions or failures caused by:

- Non-performance of maintenance requirements listed in the Operator's Manual
- The use of the engine/equipment in a manner for which it was not designed
- Abuse, neglect, improper maintenance or unapproved modifications or alterations
- Accidents for which it does not have responsibility or by acts of God

The off-road diesel engine is designed to operate on diesel fuel as specified in the Fuels, Lubricants and Coolants section in the Operators Manual. Use of any other fuel can harm the emissions control system of the engine/equipment and is not approved for use.

To the extent permitted by law John Deere is not liable for damage to other engine components caused by a failure of an emission-related part, unless otherwise covered by standard warranty.

THIS WARRANTY IS EXPRESSLY IN LIEU OF ANY OTHER WARRANTIES, EXPRESS OR IMPLIED, INCLUDING ANY WARRANTY OF MERCHANTABILITY OR FITNESS FOR A PARTICULAR PURPOSE. REMEDIES UNDER THIS WARRANTY ARE LIMITED TO THE PROVISIONS OF MATERIAL AND SERVICES AS SPECIFIED HEREIN. WHERE PERMITTED BY LAW, NEITHER JOHN DEERE NOR ANY AUTHORIZED JOHN DEERE ENGINE DISTRIBUTOR, DEALER, OR REPAIR FACILITY OR ANY COMPANY AFFILIATED WITH JOHN DEERE WILL BE LIABLE FOR INCIDENTAL OR CONSEQUENTIAL DAMAGES.

Emission_CI_EPA (18Dec09)

TS1721—UN—15JUL13
DX,EMISSIONS,EPA-19-12DEC12

Maintenance Records

Daily or Every 10 Hours

MAINTENANCE PROCEDURE		
<input type="checkbox"/> Check Engine Oil Level	<input type="checkbox"/> Clean Air Filter Dust Unloading Valve	
<input type="checkbox"/> Drain Water and Sediment from Fuel Filter		
Hours: Date: Signature: Dealer's Stamp	Hours: Date: Signature: Dealer's Stamp	Hours: Date: Signature: Dealer's Stamp
Hours: Date: Signature: Dealer's Stamp	Hours: Date: Signature: Dealer's Stamp	Hours: Date: Signature: Dealer's Stamp
Hours: Date: Signature: Dealer's Stamp	Hours: Date: Signature: Dealer's Stamp	Hours: Date: Signature: Dealer's Stamp
Hours: Date: Signature: Dealer's Stamp	Hours: Date: Signature: Dealer's Stamp	Hours: Date: Signature: Dealer's Stamp

GS25068,00015A0-19-14APR21

Maintenance Records

Weekly or Every 50 Hours

MAINTENANCE PROCEDURE		
<input type="checkbox"/> Check Coolant Level	<input type="checkbox"/> Check Transmission/Hydraulic System Oil Level	
<input type="checkbox"/> Inspect Tires	<input type="checkbox"/> Check Tire Inflation Pressure	
<input type="checkbox"/> Lubricate MFWD Axle Trunnion	<input type="checkbox"/> Lubricate Front Hitch	
<input type="checkbox"/> Lubricate Rear Hitch		
Hours: Date: Signature: Dealer's Stamp	Hours: Date: Signature: Dealer's Stamp	Hours: Date: Signature: Dealer's Stamp
Hours: Date: Signature: Dealer's Stamp	Hours: Date: Signature: Dealer's Stamp	Hours: Date: Signature: Dealer's Stamp
Hours: Date: Signature: Dealer's Stamp	Hours: Date: Signature: Dealer's Stamp	Hours: Date: Signature: Dealer's Stamp
Hours: Date: Signature: Dealer's Stamp	Hours: Date: Signature: Dealer's Stamp	Hours: Date: Signature: Dealer's Stamp

GS25068,00015A1-19-14APR21

First 100 Hours

MAINTENANCE PROCEDURE		
<input type="checkbox"/> Check and Tighten Air Intake System and Coolant System Hose Clamps	<input type="checkbox"/> Change Transmission/Hydraulic Filter	
Hours:	Hours:	Hours:
Date:	Date:	Date:
Signature:	Signature:	Signature:
Dealer's Stamp	Dealer's Stamp	Dealer's Stamp

GS25068,00015A2-19-14APR21

Every 250 Hours

MAINTENANCE PROCEDURE		
<input type="checkbox"/> Check Hitch and Drawbar for Excessive Wear	Change Activated Carbon Cab Filter	
<input type="checkbox"/> Lubricate Draft Sensing Shaft Seal		
Hours:	Hours:	Hours:
Date:	Date:	Date:
Signature:	Signature:	Signature:
Dealer's Stamp	Dealer's Stamp	Dealer's Stamp
Hours:	Hours:	Hours:
Date:	Date:	Date:
Signature:	Signature:	Signature:
Dealer's Stamp	Dealer's Stamp	Dealer's Stamp
Hours:	Hours:	Hours:
Date:	Date:	Date:
Signature:	Signature:	Signature:
Dealer's Stamp	Dealer's Stamp	Dealer's Stamp

Maintenance Records

MAINTENANCE PROCEDURE		
<input type="checkbox"/> Check Hitch and Drawbar for Excessive Wear	Change Activated Carbon Cab Filter	
<input type="checkbox"/> Lubricate Draft Sensing Shaft Seal		
Hours: Date: Signature: Dealer's Stamp	Hours: Date: Signature: Dealer's Stamp	Hours: Date: Signature: Dealer's Stamp
Hours: Date: Signature: Dealer's Stamp	Hours: Date: Signature: Dealer's Stamp	Hours: Date: Signature: Dealer's Stamp
Hours: Date: Signature: Dealer's Stamp	Hours: Date: Signature: Dealer's Stamp	Hours: Date: Signature: Dealer's Stamp

GS25068,00015A3-19-14APR21

Every 500 Hours

MAINTENANCE PROCEDURE		
<input type="checkbox"/> Change Transmission/Hydraulic Filter	<input type="checkbox"/> Check Neutral Start System	
<input type="checkbox"/> Change Engine Oil And Filter	<input type="checkbox"/> Change Fuel Filters	
<input type="checkbox"/> Change MFWD Axle Wheel Hub and Housing Oil	<input type="checkbox"/> Clean Cab Air Filters	
<input type="checkbox"/> Clean Open Crankcase Vent	<input type="checkbox"/> Lubricate Rear Axle Bearings	
Hours: Date: Signature: Dealer's Stamp	Hours: Date: Signature: Dealer's Stamp	Hours: Date: Signature: Dealer's Stamp
Hours: Date: Signature: Dealer's Stamp	Hours: Date: Signature: Dealer's Stamp	Hours: Date: Signature: Dealer's Stamp
Hours: Date: Signature: Dealer's Stamp	Hours: Date: Signature: Dealer's Stamp	Hours: Date: Signature: Dealer's Stamp
Hours: Date: Signature: Dealer's Stamp	Hours: Date: Signature: Dealer's Stamp	Hours: Date: Signature: Dealer's Stamp

Every 1000 Hours or Annually

MAINTENANCE PROCEDURE		
<input type="checkbox"/> Check Battery and Connections	<input type="checkbox"/> Check Coolant Properties	
<input type="checkbox"/> Check Seat Belts	<input type="checkbox"/> Check Fan Belt Tensioner	
<input type="checkbox"/> Change Fan Belt	<input type="checkbox"/> Change Front PTO Oil	
<input type="checkbox"/> Clean Fuel Tank Vent Filter	<input type="checkbox"/> Service Air Cleaner Elements	
<input type="checkbox"/> Lubricate Exchangeable 540/1000 rpm PTO Shaft		
Hours: Date: Signature: Dealer's Stamp	Hours: Date: Signature: Dealer's Stamp	Hours: Date: Signature: Dealer's Stamp
Hours: Date: Signature: Dealer's Stamp	Hours: Date: Signature: Dealer's Stamp	Hours: Date: Signature: Dealer's Stamp
Hours: Date: Signature: Dealer's Stamp	Hours: Date: Signature: Dealer's Stamp	Hours: Date: Signature: Dealer's Stamp

Every 1500 Hours

MAINTENANCE PROCEDURE		
<input type="checkbox"/> Change Open Crankcase Ventilation Filter	<input type="checkbox"/> Change Transmission/Hydraulic Oil and Filter	
Hours: Date: Signature: Dealer's Stamp	Hours: Date: Signature: Dealer's Stamp	Hours: Date: Signature: Dealer's Stamp
Hours: Date: Signature: Dealer's Stamp	Hours: Date: Signature: Dealer's Stamp	Hours: Date: Signature: Dealer's Stamp

GS25068,00015A7-19-14APR21

Every 3000 Hours or 3 Years

MAINTENANCE PROCEDURE		
<input type="checkbox"/> Adjust Engine Valve Clearance		
Hours: Date: Signature: Dealer's Stamp	Hours: Date: Signature: Dealer's Stamp	Hours: Date: Signature: Dealer's Stamp

GS25068,00015A6-19-14APR21

Every 4500 Hours or 5 Years

MAINTENANCE PROCEDURE		
<input type="checkbox"/> Change Transmission Dampener	<input type="checkbox"/> Change Diesel Exhaust Fluid (DEF) Dosing Unit Filter	
<input type="checkbox"/> Change Diesel Exhaust Fluid (DEF) Tank Header Suction Screen		
Hours: Date: Signature: Dealer's Stamp	Hours: Date: Signature: Dealer's Stamp	Hours: Date: Signature: Dealer's Stamp

GS25068,00015A8-19-14APR21

Every 6000 Hours or 6 Years

MAINTENANCE PROCEDURE		
<input type="checkbox"/> Change Thermostat	<input type="checkbox"/> Drain and Replace Coolant	
Hours: Date: Signature: Dealer's Stamp	Hours: Date: Signature: Dealer's Stamp	Hours: Date: Signature: Dealer's Stamp

GS25068,00015A9-19-14APR21

Change of Ownership

Machine Model:
Serial Number:
Engine Number:
Previous Owner:
Address:
Purchase Date:
Hours at Purchase:
Registration Number:
New Owner:
Address:
Dealer's Stamp (if sold through dealer)

GS25068,0003F62-19-08FEB18

Purchase Date:
Hours at Purchase:
Registration Number:
New Owner:
Address:
Dealer's Stamp (if sold through dealer)

GS25068,0003F64-19-08FEB18

Change of Ownership

Machine Model:
Serial Number:
Engine Number:
Previous Owner:
Address:
Purchase Date:
Hours at Purchase:
Registration Number:
New Owner:
Address:
Dealer's Stamp (if sold through dealer)

GS25068,0003F63-19-08FEB18

Change of Ownership

Machine Model:
Serial Number:
Engine Number:
Previous Owner:
Address:

Index

A

Access and Replace Battery	240-2
Activate AutoTrac Basic.....	60-5
Add Liquid Ballast to Tires.....	280A-4
Adjust and Check Clearance.....	280-1
Adjust Engine Valve Clearance	220-5
Adjust Flow Control.....	70B-8
Adjust Hitch Side Sway	70A-16
Adjust Lateral Float.....	70A-10
Adjust Mechanical SCV Cables.....	270B-1
Adjust PTO Speed Shift Lever	250D-1
Adjust Seat Armrests.....	90-5
Adjust Toe-In—MFWD Axle	280-13
Aftertreatment indicators overview.....	30-1
Aftertreatment system	
Emergency SCR derate override	30-4
Ash Tray and Cigarette Lighter	90-10
Attach Implement to Rear Hitch	
Ball-End.....	70A-10
Hook-End.....	70A-13
Attach PTO Driven Implement	50D-3
Automatic Exhaust Filter Cleaning.....	30-8
AutoTrac Basic About	60-18
AutoTrac Basic Map.....	60-7
AutoTrac Basic Menu	60-6
AutoTrac Basic Settings Locked.....	60-18
Autotrak Basic SF3000 Functionality.....	60-19
AutoTrac Basic Shift Size.....	60-11
AutoTrac Basic Steering System with Corner Post	
Display	60-2
AutoTrac Basic TCM Calibration.....	60-14
AutoTrac Basic Track Setup.....	60-8
AutoTrac Basic Track Width.....	60-10
AutoTrac Basic Tuning.....	60-13
AutoTrac Basic Vehicle	60-12
AutoTrac Resume Switch.....	60-4
AutoTrac Status Pie.....	60-8
AutoTrac Steering System.....	60-1
Autotrak Universal	60-20
Auxiliary Input and USB Port.....	40-10
Auxiliary Power Strip	40-12
Avoid static electricity risk when fueling	00A-4

B

Backup Alarm	40-8
Ballast Capacities.....	400-7
Ballasting Information	80A-1
Basic Menu Navigation	41-3
Battery	
Warranty	400B-1
Battery Disconnect Switch.....	40-1
Battery Handling, Safety	
Safety, Battery Handling.....	00A-12
Beacon Lights	40-6
Biodiesel fuel	200A-9
Bleed Fuel System	230-12

Bluetooth Microphone	40-10
Bolt and screw torque values	
Metric	400-1
Unified inch.....	400-2
Break-in Checks	220-1
Break-in engine oil	
Interim tier 4, final tier 4, stage IIIB, stage IV, and stage V	200A-7
Break-In Maintenance.....	220-1
Bucket Lights.....	40-3

C

Cab ROPS Certificate.....	400B-1
Cab Seats	90-3
CAN Bus	
Controller Area Network	300A-4
Carbon Dioxide Emissions	400B-3
Case Drain	70B-9
Change Diesel Exhaust Fluid (DEF) Dosing Unit Filter	
.....	230-1
Change Diesel Exhaust Fluid (DEF) Tank Header	
Suction Screen.....	230-2
Change Engine Oil and Filter	220-2
Change Fan Belt.....	220-4
Change Front PTO Oil.....	250D-1
Change Fuel Filters	230-13
Change MFWD Axle Housing Oil.....	250B-2
Change MFWD Axle Wheel Hub Oil	250B-1
Change of Ownership	500-9
Change Open Crankcase Vent Filter (OCV)	220-3
Change Transmission Dampener.....	250A-2
Change Transmission/Hydraulic Filter	270-1
Change Transmission/Hydraulic Oil and Filter	250A-1, 270-2
Change Wiper Blade	290-2
Changing Tire Sizes.....	280-4
Check Air Conditioning System.....	290-1
Check and Tighten Air Intake System and Coolant System Hose Clamps.....	230-9
Check Battery and Connections	240-1
Check Coolant Level	230-14
Check Engine and Exhaust Compartments for Debris	
.....	230-1
Check Engine Oil Level	220-1
Check Fan Belt Tensioner	220-3
Check Hitch and Drawbar for Excessive Wear	270A-2
Check Manual Brakes.....	260-1
Check Neutral Start System.....	250A-1
Check Seat Belts	290-2
Check Tire Inflation Pressure	280-1
Check Toe-In—MFWD Axle	280-13
Check Transmission Park System.....	250A-1
Check Transmission/Hydraulic System Oil Level	270-1
Clean Air Filter Dust Unloading Valve.....	230-10
Clean Cab Air Filters	290-1
Clean Diesel Exhaust Fluid (DEF) Tank	230-7

Clean Diesel Particulate Filter (DPF).....	230-1	Diesel engines, cold weather effect	200A-10
Clean Fuel Tank Vent Filter	230-14	Diesel fuel	200A-8
Clean Grille Screens and Cooling Package ...	230-10	Supplemental additives	200A-11
Clean Open Crankcase Vent.....	220-3	Diesel fuel, testing	200A-9
Clevis Drawbar.....	70A-22	Differential Lock	50C-1
Coat Hook	90-9	Disable AutoTrac Basic	60-4
Cold Weather Start	20-5	Disabled Exhaust Filter Cleaning	30-8
Come Home Mode	100-3	Disengage AutoTrac Basic	60-5
Connect Hydraulic Hoses.....	70B-3	Display Settings.....	41-7
Connect to Mid-Mount SCVs.....	70B-4	Display Settings Menu	41-6
Connect to Rear SCVs.....	70B-4	Do Not Modify Fuel System	230-11
Control Power Hop - MFWD	280A-3	Dome Light	40-7
Control Unit Addresses		Doors.....	90-1
Diagnostic	300A-3	Downhill Operation in Slippery Conditions.....	50A-5
Controls		Drain Diesel Exhaust Fluid (DEF) Tank.....	230-7
Console		Drain Water and Sediment from Fuel Filter	230-11
Cab.....	10-2	Drawbar Capacities.....	400-6
Foot Operated	10-1	Drawbar Settings	70A-22
Front Console.....	10-1	Drawn Implement Connection.....	70A-22
Front PTO	10-5	Drivetrain Maintenance	250-1
Heat		Drivetrain Operation.....	50-1
Air Conditioning.....	10-5	Dual Wheel Usage	280-4
Rear Hitch.....	10-4		
Rear PTO.....	10-4	E	
Rear SCVs	10-4	Effect of cold weather on diesel engines	200A-10
Transmission.....	10-3	Electrical Specifications.....	400-5
Convenience Outlets	40-12	Emission system	
Coolant		Certification label	400B-2
Diesel engine		Emissions	
Engine with wet sleeve cylinder liners.....	200A-1	Required language	
John deere COOL-GARD II coolant extender	200A-2	EPA	230-1
Mixing with concentrate, water quality	200A-2	Emissions Performance	
Testing freeze point	200A-3	Tampering	2
Warm temperature climates	200A-2	Empty Rear SCV Oil Collection Bottle	270B-1
CoolScan	200A-12	Enable AutoTrac Basic.....	60-3
Correct Reversed Cylinder Response.....	70B-4	Engine and PTO Power.....	400-4
Correct Tire Selection		Engine Block Coolant Heater	20-7
MFWD Ratio	280-3	Engine Fuel System and Power Rating.....	20-2
Correction Factors for Other Tire Sizes.....	50A-7	Engine Indicator and Gauges	20-3
Creeper Gear Operation	50A-5	Engine Menu	20-1, 30-7
		Engine oil	
D		Break-In	
Deere & Company Trademarks.....	00-1	Interim tier 4, final tier 4, stage IIIB, stage IV, and	
DEF		stage V	200A-7
Disposal	200A-4	Diesel	
Storing	200A-4	Interim tier 4, final tier 4, stage IIIB, stage IV, and	
Tank, refilling.....	200A-4	stage V	200A-6
Testing	200A-5	Service interval for operation at high altitude	200A-5
Use in SCR equipped engines.....	200A-3	Engine oil and filter service intervals	
Diagnostic Trouble Codes	300A-2	Interim tier 4, final tier 4, stage IIIB, stage IV, and	
Diagnostics Menu.....	300A-2	stage V	
Diesel engine oil		0.12 L/kW or greater oil pan	200A-6
Interim tier 4, final tier 4, stage IIIB, stage IV, and		Operation at high altitude.....	200A-5
stage V	200A-6	Engine Specifications	400-4
Service interval for operation at high altitude	200A-5	Engine Speeds and Operational Procedures	20-6

Maintenance Counters and Intervals.....	41-8	Operator Presence	40-14
Maintenance Menu	41-8		
Maintenance Record		P	
Daily or Every 10 Hours	500-1	Paint and Finish Care	200B-2
Every 500 Hours.....	500-5	Parked Exhaust Filter Cleaning	30-8
Every 1000 Hours or Annually	500-6	Permissible Load	400-6
Every 1500 Hours	500-7	Position Center Link.....	70A-10
Every 3000 Hours or 3 Years	500-7	Power Beyond	70B-8
Every 4500 Hours or 5 Years	500-8	Power Outlet	40-12
Every 6000 Hours or 6 Years	500-8	Prepare Implement	70A-9
First 100 Hours	500-3	Primary Display	41-1
Weekly or Every 50 Hours	500-2	Product View	00-1
Map Light.....	40-8	PTO Alarm.....	50D-7
Match Machine Power to Implement.....	50D-1, 70A-1	PTO Automatic Disengage	50D-7
Measure Wheel Slip.....	280A-4	PTO Drive Shaft Shield	50D-1
Mechanical Front-Wheel Drive (MFWD On/Auto/Brake Assist).....	50B-1	PTO Engine Speeds	400-5
Metric bolt and screw torque values	400-1	PTO Guard	50D-1
MFWD Ratio		PTO Shield	50D-1
Tire Selection	280-3		
Mid-Mount SCV Controls and Components	70B-2	Q	
Mid-Mount SCV Joystick Controls	10-3	Qualified emergency use	
Mirrors.....	90-2	SCR derate override option	30-4
Mixing lubricants	200A-12	Quick Coupler	70A-17
Monitor Mounts	90-9		
Motor Return	70B-9	R	
Multipurpose Extreme Pressure (EP) grease	200A-12	Radio.....	40-10
		Radio Antenna	40-11
O		Reactivate AutoTrac Basic on Next Pass.....	60-5
Off Level Operation.....	50-1	Rear Hitch Components	70A-2
Oil		Rear Hitch Controls	70A-1
Brake.....	200A-13	Rear Hitch Lift Capacities.....	400-5
Engine		Rear Hitch Menu.....	70A-5
Interim tier 4, final tier 4, stage IIIB, stage IV, and stage V	200A-6	Rear SCV Controls and Components	70B-1
Gear case	200A-13	Rear SCV Oil Collection	70B-10
Hydraulic.....	200A-13	Rear Tow Points	100-5
Steering.....	200A-13	Rear Wheel Ballast.....	280A-3
Transmission	200A-13	Rear Wheel Tread Width Limitations.....	280-5
Oilscan	200A-12	Rear Window Cable Routing	90-9
Open Center Hydraulics	70-1	Rear Wiper and Washer	40-9
Operate Electrohydraulic Draft Control.....	70A-4	Recommended Dealer Performed Service	230-1
Operate Electrohydraulic Height Limit Control	70A-5	Record Cab Serial Number.....	400A-2
Operate Electrohydraulic Hitch Fender Switch	70A-5	Record Engine Serial Number	400A-2
Operate Electrohydraulic Position Control	70A-2	Record Front Axle Serial Number	400A-1
Operate Electrohydraulic Rate-of-Drop Control	70A-4	Record Product Identification Number	400A-1
Operate Front PTO.....	50D-6	Record Transmission Serial Number.....	400A-2
Operate Guidance Systems Safely	60-3	Reduce Fuel Consumption	30-7
Operate Hydraulic Motor With Rear SCV.....	70B-6	Refueling, avoid static electricity risk.....	00A-4
Operate Key Switch	20-4	Regions and Country Versions.....	00-4
Operate Loader with Rear SCV.....	70B-7	Registered Trademarks	00-2
Operate Manual Lower for Electrohydraulic Hitch	70A-8	Remove Liquid Ballast from Tires	280A-4
Operate Power Beyond With Rear SCV	70B-7	Remove Machine from Storage.....	100-6
Operate Rear PTO	50D-5	Replace Bucket Light.....	240-8
Operate Rear Remote PTO	50D-5	Replace Dome Light Bulb	240-10
		Replace Fuses	240-3
		Replace Fusible Link	240-2
		Replace Halogen Headlight Bulb	240-5

Replace Halogen Worklight Bulb	240-9
Replace LED Beacon Light.....	240-10
Replace LED Headlight	240-6
Replace LED Worklight	240-9
Replace Loader Headlight Bulb.....	240-7
Replace Map Light Bulb	240-10
Replace Right-Hand Console Light Bulb	240-11
Replace Tail/Turn/Brake Light Bulb.....	240-8
Replace Warning Light Bulb.....	240-8
Required machine stop warning	20-1
Restart Engine That Has Run Out of Fuel	20-7
Right-Hand Console Light	40-8
Road Transportation.....	100-2
Run Engine.....	20-5
Run Pages.....	41-4

S

Safety	
Protect against noise.....	00A-2
Rotating drivelines, stay clear.....	00A-5
Safe maintenance, practice	00A-14
Tires, service safely.....	00A-17
Towed equipment, transport at safe speeds	00A-9
Tractor, operating safely.....	00A-6
Use caution on slopes, uneven terrain, and rough ground	00A-10
Safety, Avoid High-Pressure Fluids	
Avoid High-Pressure Fluids	00A-18
Safety, Fire Prevention	
Fire Prevention.....	00A-3
Safety, Forestry Operations	
Limited Use in Forestry Operation	00A-7
Safety, Handle Fuel Safely, Avoid Fires	
Avoid Fires, Handle Fuel Safely	00A-2
Safety, lubricants.....	200A-1
Safety, ROPS	
ROPS, Keep Installed Properly.....	00A-4
Safety, Steps and Handholds	
Use Steps and Handholds Correctly	00A-5
Safety, Tightening Wheel Retaining Bolts/Nuts	
Tightening Wheel Retaining Bolts/Nuts	00A-17
Satellite Module and Antenna.....	40-11
SCR	
System overview	30-3
Select Ballast Carefully	280A-1
Select Correct PTO Speed	50D-4
Select Front Tire Rolling Direction.....	280-4
Select PTO Drawbar Position	50D-2
Service ADVISOR Connector	40-14
Service Air Cleaner Elements.....	230-8
Service as Required.....	200B-1
Service Brakes.....	60-1
Service Filter Cleaning.....	30-8
Service Interval Chart	200-2
Set Fender Position	280B-2
Set Pivoting Fender Bracket	280B-2

Set SCV Detents.....	70B-5
Set Steering Stops	280-13
Set Tread—Multi-Position MFWD Wheels	280-6
Set Tread—Multi-Position Rear Wheels	280-8
Set Tread—Two-Position MFWD Wheels.....	280-5
Signal words, understand.....	00A-1
Single-Acting Cylinders	70B-5
Sound Level.....	400-7
Speakers.....	40-10
StarFire Correction Mode.....	60-14
StarFire GPS Status.....	60-17
Starfire Receiver Mount.....	290-3
StarFire USB Drive	60-16
Start Engine	20-4
Steering Wheel.....	90-6
Stop Engine	20-7
STOP, Service, Information Alert Indicators, and Alarms	
Alarms	300A-1
Storage Drawer	90-8
Storing fuel	200A-8

T

Tail and Brake Lights	40-4
Testing diesel fuel	200A-9
Tighten Wheel Bolts Correctly	280-10
Tighten Wheel Bolts—MFWD Axle	280-11
Tighten Wheel Bolts—Rear Axle.....	280-11
Tire Inflation Pressure Guidelines	280-2
Tire Pressures.....	280-1
Tire Sidewall Information	280-2
Tires, service safely	00A-17
Tool Box	80B-1
Torque charts	
Metric	400-1
Unified inch.....	400-2
Tow Machine	100-3
Towed equipment, transport at safe speeds	00A-9
Towing Loads	100-2
Tractor, operating safely	00A-6
Transmission Indicators.....	50A-2
Transmission Menu.....	50A-1
Transmission Settings.....	50A-1
Troubleshooting	
Brakes	300-10
Electrical	300-8
Engine	300-1
Heat and Air Conditioning	300-5
Hitch.....	300-11
Hydraulics	300-10
Selective Control Valves	300-12
Transmission	300-9
Turn Signals.....	40-4

U

Unified inch bolt and screw torque values.....	400-2
--	-------

Use Booster Battery or Charger 240-1
Use Correct Tire Combinations 280-3

W

Warm Transmission/Hydraulic Oil 70-1
Warning Lights 40-5
Warranty
 Non-road emissions control warranty statement--
 compression ignition
 CARB 400B-3
 EPA 400B-11
Wash Machine 200B-2
Weight Distribution 400-6
Wheels and Tires Information 80-1
Window Shades 90-2
Windows 90-2
Work Monitor Menu 41-7
Work Monitor Operation 41-8

John Deere Service

Technical Information

Technical information can be purchased from John Deere. Publications are available in print or CD-ROM format.

Orders can be made using one of the following:

- John Deere Technical Information Store: www.JohnDeere.com/TechInfoStore
- Call 1-800-522-7448
- Contact your John Deere dealer

Available information includes:



TS189—UN—17JAN89

PARTS CATALOGS list service parts available for your machine with exploded view illustrations to help you identify the correct parts. It is also useful in assembling and disassembling.



TS191—UN—02DEC88

OPERATOR'S MANUALS providing safety, operating, maintenance, and service information.



TS224—UN—17JAN89

TECHNICAL MANUALS outlining service information for your machine. Included are specifications, illustrated assembly and disassembly procedures, hydraulic oil flow diagrams, and wiring diagrams. Some products have separate manuals for repair and diagnostic information. Some components, such as engines, are available in a separate component technical manual.



TS1663—UN—10OCT97

EDUCATIONAL CURRICULUM including five comprehensive series of books detailing basic information regardless of manufacturer:

- Agricultural Primer series covers technology in farming and ranching.
- Farm Business Management series examines “real-world” problems and offers practical solutions in the areas of marketing, financing, equipment selection, and compliance.
- Fundamentals of Services manuals show you how to repair and maintain off-road equipment.
- Fundamentals of Machine Operation manuals explain machine capacities and adjustments, how to improve machine performance, and how to eliminate unnecessary field operations.
- Fundamentals of Compact Equipment manuals provide instruction in servicing and maintaining equipment up to 40 PTO horsepower.

DX,SERV LIT-19-07DEC16

John Deere Is At Your Service



TS201—UN—15APR13

CUSTOMER SATISFACTION is important to John Deere.

Our dealers strive to provide you with prompt, efficient parts and service:

- Maintenance and service parts to support your equipment.
- Trained service technicians and the necessary diagnostic and repair tools to service your equipment.

CUSTOMER SATISFACTION PROBLEM RESOLUTION PROCESS

Your John Deere dealer is dedicated to supporting your equipment and resolving any problem you may experience.

1. When contacting your dealer, be prepared with the following information:

- Machine model and product identification number
- Date of purchase
- Nature of problem

2. Discuss problem with dealer service manager.

3. If unable to resolve, explain problem to dealership manager and request assistance.

4. If you have a persistent problem your dealership is unable to resolve, ask your dealer to contact John Deere for assistance. Or contact the Ag Customer Assistance Center at 1-866-99DEERE (866-993-3373) or e-mail us at www.deere.com/en_US/ag/contactus/.

DX,IBC,2-19-02APR02
